

# Built-in Oven

---

User & Installation manual

NV75T8979\*\* / NV75T8879\*\*

---



**SAMSUNG**

# Contents

## Using this manual 3

The following symbols are used in this user manual 3

## Safety instructions 3

Important safety precautions 3

Correct Disposal of This Product (Waste Electrical & Electronic Equipment) 6

Auto energy saving function 6

## Installation 7

What's included 7

Power connection 8

Cabinet mount 8

## Before you start 11

Control panel 11

Initial settings 12

New oven smell 13

Smart safety mechanism 13

Soft closing door (gentle, safe, and silent) 13

Assembling the steam container (applicable models only) 14

Accessories 14

Water reservoir 16

## Operations 17

Oven modes 17

Steam assisted modes 19

Dual cook modes 21

Cooking with the meat probe (applicable models only) 23

Special Function 24

Healthy Cook (applicable models only) 26

Auto Cook 26

Timer 27

Cleaning 28

Settings 30

Lock 31

## Cooking Smart 32

Manual cooking 32

Auto Cook programmes 40

Special Function 48

Test dishes 49

Collection of frequent Auto Cook recipes 51

## Maintenance 54

Cleaning 54

Replacement 57

## Troubleshooting 58

Checkpoints 58

Information codes 60

## Technical specifications 61

## Appendix 62

Product data sheet 62

Open Source Announcement 63

## Using this manual

Thank you for choosing SAMSUNG Built-In Oven. This User Manual contains important information on safety and instructions intended to assist you in the operation and maintenance of your appliance. Please take the time to read this User Manual before using your oven and keep this book for future reference.

### The following symbols are used in this user manual

#### WARNING

Hazards or unsafe practices that may result in **severe personal injury, death and/or property damage**.

#### CAUTION

Hazards or unsafe practices that may result in **personal injury and/or property damage**.

#### NOTE

Useful tips, recommendations, or information that helps users manipulate the product.

## Safety instructions

Installation of this oven must be performed only by a licensed electrician. The installer is responsible for connecting the appliance to the mains power supply in observance of the relevant safety recommendations.

### Important safety precautions

#### WARNING

This appliance is not intended for use by persons (including children) with reduced physical, sensory or mental capabilities, or lack of experience and knowledge, unless they have been given supervision or instruction concerning use of the appliance by a person responsible for their safety.

Children should be supervised to ensure that they do not play with the appliance.

The means for disconnection must be incorporated in the fixed wiring in accordance with the wiring rules.

This Appliance should be allowed to disconnection from the supply after installation. The disconnection may be achieved by having the plug accessible or by incorporating a switch in the fixed wiring in accordance with the wiring rules.

If the supply cord is damaged, it must be replaced by the manufacturer, its service agent or similarly qualified persons in order to avoid a hazard.

## Safety instructions

The method of fixing stated is not to depend on the use of adhesives since they are not considered to be a reliable fixing means.

This appliance can be used by children aged from 8 years and above and persons with reduced physical, sensory or mental capabilities or lack of experience and knowledge if they have been given supervision or instruction concerning use of the appliance in a safe way and understand the hazards involved. Children shall not play with the appliance. Cleaning and user maintenance shall not be made by children without supervision. Keep the appliance and its cord out of reach of children less than 8 years.

During use the appliance becomes hot. Care should be taken to avoid touching heating elements inside the oven.

**WARNING: Accessible parts may become hot during use. Young children should be kept away.**

Do not use harsh abrasive cleaners or sharp metal scrapers to clean the oven door glass since they can scratch the surface, which may result in shattering of the glass.

If this appliance has cleaning function, excess spillage must be removed before cleaning and all utensils should not be left in the oven during steam cleaning or self cleaning. The cleaning function depends on the model.

If this appliance has cleaning function, during cleaning conditions the surfaces may get hotter than usual and children should be kept away. The cleaning function depends on the model.

Only use the temperature probe recommended for this oven. (Meat probe model only)

A steam cleaner is not to be used.

**WARNING: Ensure that the appliance is switched off before replacing the lamp to avoid the possibility of electric shock.**

The appliance must not be installed behind a decorative door in order to avoid overheating.

**WARNING: The appliance and its accessible parts become hot during use. Care should be taken to avoid touching heating elements. Children less than 8 years of age shall be kept away unless continuously supervised.**

**CAUTION: The cooking process has to be supervised. A short term cooking process has to be supervised continuously.**

The door or the outer surface may get hot when the appliance is operating.

The temperature of accessible surfaces may be high when the appliance is operating. The surfaces are liable to get hot during use.

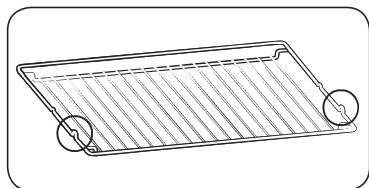

Insert the wire rack into position with the protruding parts (stoppers on both sides) towards the front so that the wire rack supports the rest position for large loads.

#### **⚠ CAUTION**

If the oven has been damaged in transport, do not connect it.

This appliance must be connected to the mains power supply only by a specially licensed electrician.

In the event of a fault or damage to the appliance, do not attempt to operate it.

Repairs should be performed by a licensed technician only. Improper repair may result in considerable danger to you and others. If your oven needs repair, contact a SAMSUNG Service center or your dealer.

Electrical leads and cables should not be allowed to touch the oven.

The oven should be connected to the mains power supply by means of an approved circuit breaker or fuse. Never use multiple plug adapters or extension leads.

The power supply of the appliance should be turned off when it is being repaired or cleaned.

Take care when connecting electrical appliances to sockets near the oven.

If this appliance has a vapour or steam cooking function, do not operate this appliance when the water supply cartridge is damaged. (Vapour or steam function model only)

When the cartridge is cracked or broken, do not use it and contact your nearest service center. (Vapour or steam function model only)

This oven has been designed only for the cooking of household foods.

During use, the oven interior surfaces become hot enough to cause burns. Do not touch heating elements or interior surfaces of the oven until they have had time to cool.

Never store flammable materials in the oven.

The oven surfaces become hot when the appliance is operated at a high temperature for an extended period of time.

When cooking, take care when opening the oven door as hot air and steam can escape rapidly.

When cooking dishes that contain alcohol, the alcohol may evaporate due to the high temperatures and the Vapour can catch fire if it comes into contact with a hot part of the oven.

For your safety, do not use high-pressure water cleaners or steam jet cleaners.

Children should be kept at a safe distance when the oven is in use.

Frozen foods such as pizzas should be cooked on the big grid. If the baking tray is used, it may become deformed due to the great variation in temperatures.

Do not pour water into the bottom of the oven when it is hot. This could cause damage to the enamel surface.

The oven door must be closed during cooking.

Do not line the bottom of the oven with aluminum foil and do not place any baking trays or tins on it. The aluminum foil blocks the heat, which may result in damage to the enamel surfaces and cause poor cooking results.

## Safety instructions

Fruit juices will leave stains, which can become permanent on the enamel surfaces of the oven.

When cooking very moist cakes, use the deep pan.

Do not rest bakeware on the open oven door.

Keep children away from the door when opening or closing it as they may bump themselves on the door or catch their fingers in the door.

Do not step, lean, sit or place heavy items on the door.

Do not open the door with unnecessarily strong force.

**WARNING:** Do not disconnect the appliance from the main power supply even after the cooking process is completed.

**WARNING:** Do not leave the door open while oven is cooking.

## Correct Disposal of This Product (Waste Electrical & Electronic Equipment)

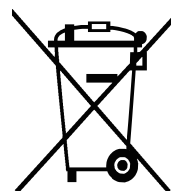

(Applicable in countries with separate collection systems)

This marking on the product, accessories or literature indicates that the product and its electronic accessories (e.g. charger, headset, USB cable) should not be disposed of with other household waste at the end of their working life. To prevent possible harm to the environment or human health from uncontrolled waste disposal, please separate these items from other types of waste and recycle them responsibly to promote the sustainable reuse of material resources.

Household users should contact either the retailer where they purchased this product, or their local government office, for details of where and how they can take these items for environmentally safe recycling.

Business users should contact their supplier and check the terms and conditions of the purchase contract. This product and its electronic accessories should not be mixed with other commercial wastes for disposal.

For information on Samsung's environmental commitments and product-specific regulatory obligations, e.g. REACH, WEEE, Batteries, visit : [samsung.com/uk/aboutsamsung/samsungelectronics/corporatecitizenship/data\\_corner.html](https://samsung.com/uk/aboutsamsung/samsungelectronics/corporatecitizenship/data_corner.html)

## Auto energy saving function

- If no user input is made for a certain time while the appliance is operating, the appliance stops operation and goes to Standby state.
- Light : During cooking process, you can switch off Oven lamp by pressing 'Oven light' button. For energy saving, the oven lighting is switched off a few minutes after cooking programme has started.

# Installation

## ⚠ WARNING

- This oven must be installed by a qualified technician. The installer is responsible for connecting the oven to the main power, while observing the relevant safety regulations of your area.
- This appliance is designed for use up to a maximum altitude of 2,000 metres.

## What's included

Make sure all parts and accessories are included in the product package. If you have a problem with the oven or accessories, contact a local Samsung customer centre or the retailer.

## Oven at a glance

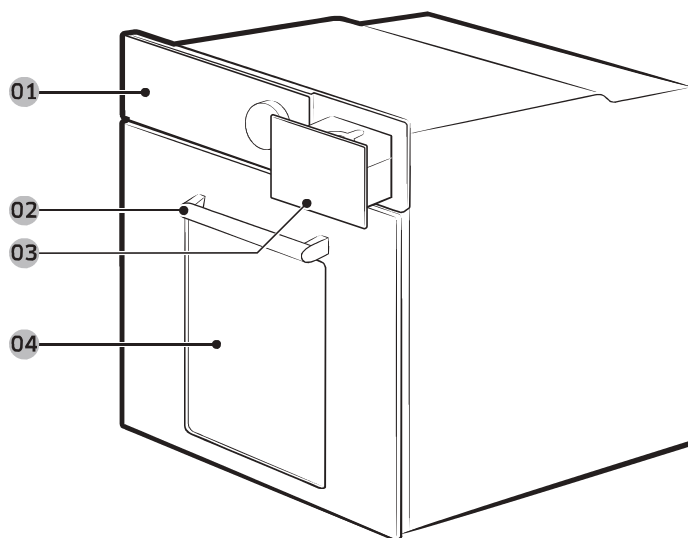

- 01 Control panel      02 Door handle      03 Water reservoir  
04 Door

## Accessories

The oven comes with different accessories that help you prepare different types of food.



Wire rack



Wire rack insert \*



Baking tray \*



Universal tray \*



Extra-deep tray \*



Rotisserie spit \*

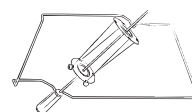

Rotisserie spit and Shashlik \*

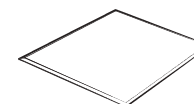

Divider

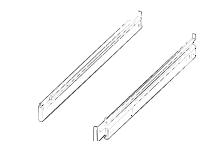

Telescopic rail \*

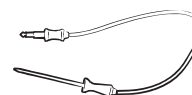

Meat probe \*

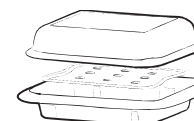

Steam container \*

## 📖 NOTE

Availability of accessories with an asterisk (\*) depends on the oven model.

## ⚠ CAUTION

Remove the child lock before using the Pyrolytic cleaning programme to avoid vent blockages that can heat up the door.

# Installation

## Power connection

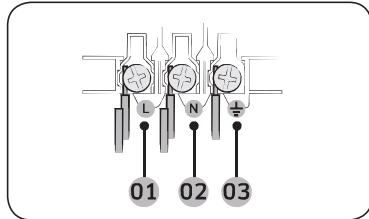

- 01** BROWN or BLACK
- 02** BLUE or WHITE
- 03** YELLOW and GREEN

Plug the oven into an electrical socket. If a plug-type socket is not available due to allowable current limitations, use a multi-pole isolator switch (with at least 3 mm spacing in-between) in order to meet safety regulations. Use a power cord of sufficient length that supports the specification H05 RR-F or H05 VV-F, min. 1.5-2.5 mm<sup>2</sup>.

Rated current (A)	Minimum cross-sectional area
10 < A ≤ 16	1.5 mm <sup>2</sup>
16 < A ≤ 25	2.5 mm <sup>2</sup>

Check the output specifications on the label attached to the oven.

Open the rear cover of the oven using a screwdriver, and remove the screws on the cord clamp. Then, connect the power lines to the relevant connection terminals.

The (⏚)-terminal is designed for earthing. First connect the yellow and green lines (earthing), which must be longer than the others. If you use a plug-type socket, the plug must remain accessible after the oven is installed. Samsung is not responsible for accidents caused by missing or faulty earthing.

### ⚠ WARNING

Do not step on or twist the wires during installation, and keep them away from heat-emitting parts of the oven.

## Cabinet mount

If installing the oven in a built-in cabinet, the cabinet must have its plastic surfaces and adhesive parts resistant to temperatures in accordance to EN 60335. Samsung is not responsible for damage to furniture from the oven's heat emission.

The oven must be properly ventilated. For ventilation, leave a gap of about 50 mm between the lower shelf of the cabinet and the supporting wall. If you install the oven under a cooktop, follow the cooktop's installation instructions.

### Required dimensions for installation

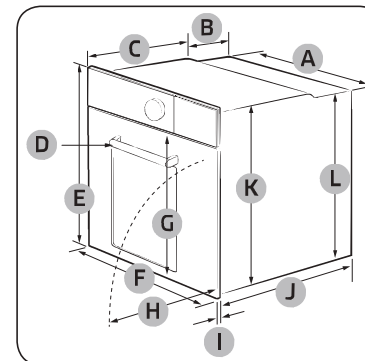

Oven (mm)

<b>A</b>	560	<b>G</b>	Max. 507.5
<b>B</b>	177	<b>H</b>	Max. 494
<b>C</b>	372	<b>I</b>	21
<b>D</b>	Max. 50	<b>J</b>	549
<b>E</b>	596	<b>K</b>	579
<b>F</b>	595	<b>L</b>	559

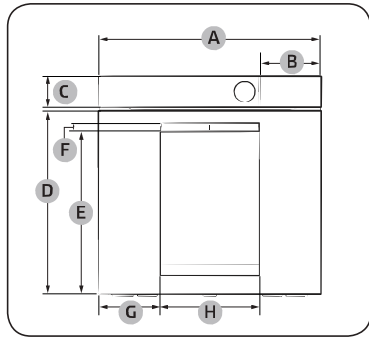

Oven (mm)

A	595	E	439
B	163	F	22
C	85	G	165
D	495.5	H	264

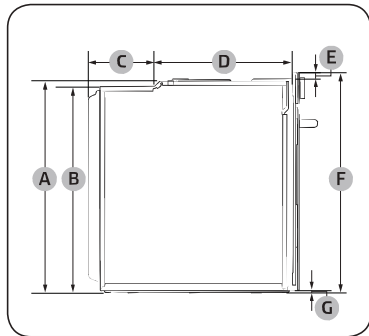

Oven (mm)

A	579	E	17
B	559	F	596
C	177	G	7
D	372		

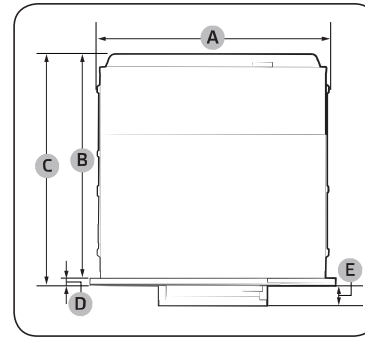

Oven (mm)

A	560	D	21
B	549	E	50
C	570		

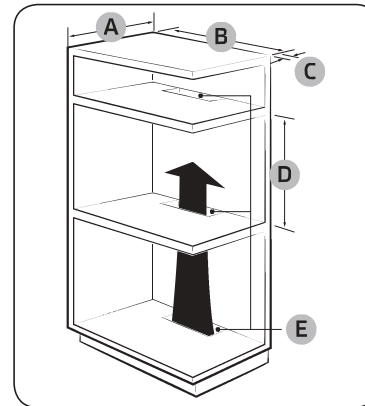

Built-in cabinet (mm)

A	Min. 550
B	Min. 560
C	Min. 50
D	Min. 590 - Max. 600
E	Min. 460 x Min. 50

**NOTE**

The built-in cabinet must have vents (E) to ventilate heat and circulate the air.

# Installation

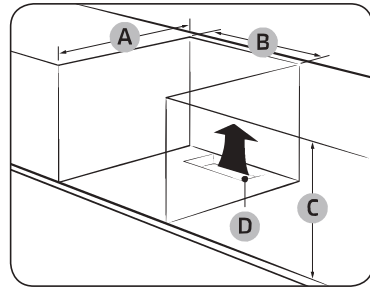

Under-sink cabinet (mm)

<b>A</b>	Min. 550
<b>B</b>	Min. 560
<b>C</b>	Min. 600
<b>D</b>	Min. 460 x Min. 50

**NOTE**

- The built-in cabinet must have vents (**D**) to ventilate heat and circulate the air.
- Minimum height requirement (**C**) is for oven installation alone.

**Installing with a hob**

To install a hob on top of the oven, check the installation guide of the hob for the installation space requirement (**\***).

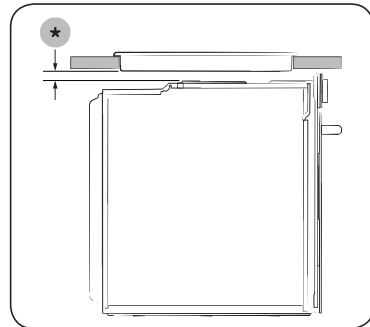

## Mounting the oven

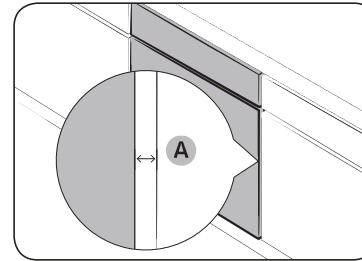

Make sure to leave a gap (**A**) of at least 5 mm between the oven and each side of the cabinet.

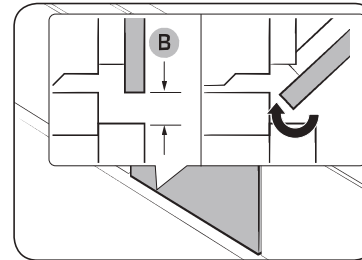

Secure at least 2 mm of gap (**B**) so that the door opens and closes smoothly.

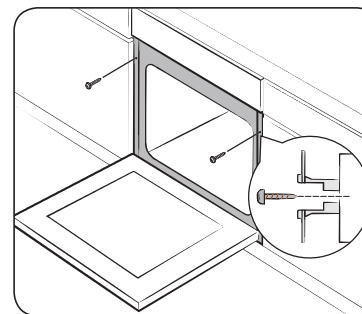

Fit the oven into the cabinet and fix the oven firmly on both sides using 2 screws.

After installation is complete, remove the protective film, tape, and other packing material, and take out the provided accessories from inside the oven. To remove the oven from the cabinet, first disconnect power to the oven and remove 2 screws on both sides of the oven.

**⚠ WARNING**

The oven requires ventilation for normal operation. Do not block the vents under any circumstance.

**📖 NOTE**

The actual appearance of the oven may differ with the model.

## Before you start

### Control panel

The oven's control panel features a display (non-touch), dial knob and touch buttons to control the oven. Please read the following information to learn about the oven's control panel.

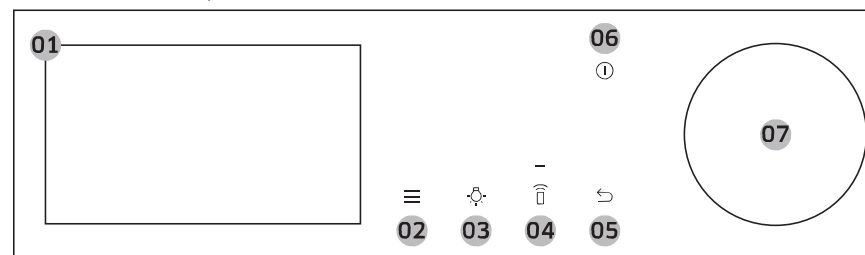

<b>01</b> Screen	Displays the menu, information, and cooking progress.
<b>02</b> Options	Tap to see the Options list.
<b>03</b> Light	Tap to turn the oven light on or off.
<b>04</b> Smart Control	Tap to turn the Smart Control function on or off. <b>📖 NOTE</b> Easy Connection should be set prior to use this function.
<b>05</b> Back	Tap to move to the previous screen.
<b>06</b> Power	Tap to turn the screen on or off. <b>📖 NOTE</b> Only the <b>Power</b> button can stop the operation of the oven when the door is open.
<b>07</b> Dial Knob	Turn left and right to navigate through the menus and lists. An item will be underlined to show you where you are on the screen. Press to select the underlined item.

Before you start

## Before you start

### Initial settings

When you turn on the oven for the first time, the Welcome screen appears with the Samsung logo. Follow the on-screen instructions to complete the initial settings. You can change the initial settings later by accessing the Settings screen.

1. On the welcome screen, select **Start setup**, and then press the **Dial Knob**.
2. Set the language.
  - a. Select the language, and then press the **Dial Knob**.
  - b. Select **Next**, and then press the **Dial Knob**.
3. Agree with the "**Terms and Conditions**" and "**Privacy Policy**".
4. Connect your appliance to the SmartThings app.
  - a. On the Mobile Experience screen, select **Next**, and then press the **Dial Knob**.
  - b. Scan the QR code on the screen with your smartphone and follow the onscreen instruction on your phone to complete the connection.
    - If you do not wish to proceed this step, select **Skip**, and then press the **Dial Knob** to proceed next step.
  - c. Once you get the message that you are successfully connected, select **OK**, and then press the **Dial Knob**.

5. Set the time zone.
  - a. Select your time zone, and then press the **Dial Knob**.
  - b. Select **Next**, and then press the **Dial Knob**.
6. Set the date.
  - a. Select the day, month, and year. Press the **Dial Knob** after selecting each item.
  - b. Select **Next**, and then press the **Dial Knob**.

#### NOTE

Skip this step if you have connected your appliance to the SmartThings app.

7. Select the time.
  - a. Set the hour and minute. Press the **Dial Knob** after selecting each item.
  - b. Select **Next**, and then press the **Dial Knob**.

#### NOTE

Skip this step if you have connected your appliance to the SmartThings app.

8. Select **Done**, and then press the **Dial Knob** to complete the setting.
  - Guide for first use screen appears. You can select **LEARN MORE**, and then press the **Dial Knob** to see the guide or select **LATER**, and then press the **Dial Knob** to skip this step.

### Setting the screen to stay always on

The screen automatically turns off after a certain time. If you want to set the screen to stay on all the time, follow the below instructions.

1. Touch the  button on the control panel.
2. Select **Settings**, and then press the **Dial Knob**.
3. On the Settings screen, select **Display**, and then press the **Dial Knob**.
4. On the Display screen, select **Timeout**, and then press the **Dial Knob**.
5. Select **Always on**, and then press the **Dial Knob**.

#### NOTE

- Energy consumption may increase depending on your setting.
- When the timeout setting is set to "**Always on**", the brightness of the LCD automatically changes to level 2 if there is no action for 3 minutes.
- "**Always on**" setting is available only when the screen saver is set to On.

### New oven smell

Before using the oven for the first time, clean inside the oven to remove the new oven smell.

1. Remove all accessories from inside the oven.
2. Run the oven with Convection 200 °C or Conventional 200 °C for an hour. This will burn any remaining production substances in the oven.
3. When complete, turn off the oven.

### Smart safety mechanism

If you open the door while the oven is operating, the oven light turns on and both the fan and the heating elements stop operation. This is to prevent physical injuries such as burns as well as to prevent unnecessary energy loss. When this happens, simply close the door and the oven continues to operate normally because this is not a system failure.

### Soft closing door (gentle, safe, and silent)

The Samsung Built-in Oven features a soft closing door that gently, safely, and silently closes.

When closing the door, the specially designed hinges catch the door a few centimetres before the final position. This is the perfect touch for added comfort, allowing the door to be closed silently and gently.

(Availability of this feature depends on the oven model.)

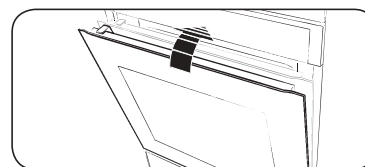

The door starts to be closed softly at about 15 degrees and completely closed within approx. 5 seconds.

# Before you start

## Assembling the steam container (applicable models only)

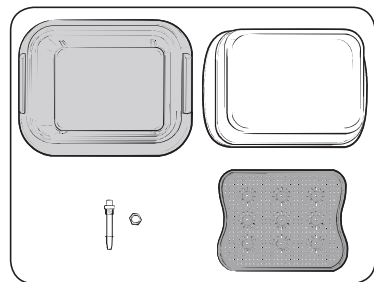

1. Check and make sure you have all the parts for the steam container.
  - Parts includes glass lid, metal pan, steam tray, and steam nozzle.

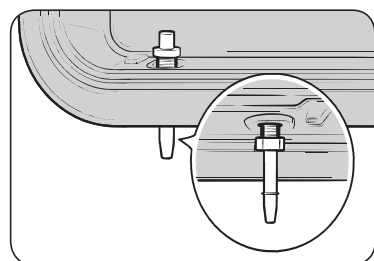

2. Insert the steam nozzle to the hole on the right-rear side of the metal pan, and then tighten the provided nut.

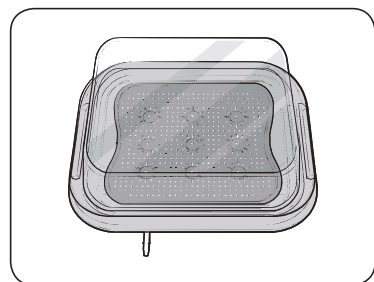

3. Put the steam tray in the metal pan, and then close the glass lid to use it in the oven.

## Accessories

For first time use, clean the accessories thoroughly with warm water, detergent and a soft clean cloth.

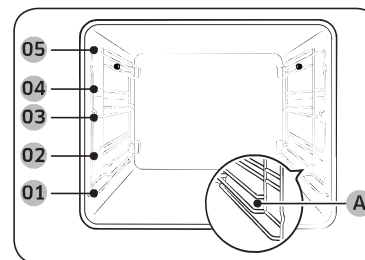

- 01 Level 1
- 02 Level 2
- 03 Level 3
- 04 Level 4
- 05 Level 5
- (A) Steam container level

- Insert the accessory to the correct position inside of the oven.
- **Steam container level (A)** is only for the steam container. Do not put the steam container on any other level, and do not put any other accessories on the **steam container level (A)**.
- Allow at least a 1 cm space from the accessory and the bottom of the oven, and from any other accessory.
- Take caution in removing cookware and/or accessories out of the oven. Hot meals or accessories can cause burns.
- The accessories may be deformed while they are gaining heat. Once they have cooled down, they will recover their original appearance and performance.

## Basic use

For better cooking experience, familiarise yourself with how to use each accessory.

Wire rack	The wire rack is designed for grilling and roasting. Insert the wire rack into position with the protruding parts (stoppers on both sides) towards the front.
Wire rack insert *	The wire rack insert is used with the tray, and prevents liquid from dropping onto the bottom of the oven.
Baking tray *	The baking tray (depth: 20 mm) is used to bake cakes, cookies, and other pastries. Put the slanted side to the front.
Universal tray *	The universal tray (depth : 30 mm) is used for cooking and roasting. Use the wire-tray insert to prevent liquid from dropping onto the bottom of the oven. Put the slanted side to the front.
Extra-deep tray *	The extra-deep tray (depth: 50 mm) is used for roasting with or without the wire-tray insert. Put the slanted side to the front.
Rotisserie spit *	The rotisserie spit is used for grilling food such as chicken. Use the rotisserie spit only in Single mode at level 4 where the spit adapter is available. Unscrew the spit handle to remove while grilling.

Rotisserie spit and Shashlik *	<p>Put the tray at rack position 1 to collect cooking juices, or on the bottom of the oven for a large serving of meat. It is recommended to use the spit accessories for meat under 1.5 kg.</p> <ol style="list-style-type: none"> <li>1. Insert the spit into the meat. To help insert the spit, screw the spit handle toward the blunt end.</li> <li>2. Put parboiled potatoes and vegetables around the meat.</li> <li>3. Put the cradle at the middle tray position with the "V" shape to the front. Rest the spit onto the cradle with the pointed end backward and gently push until the tip of the spit enters the turning mechanism at the back of the oven. The blunt end of the spit must rest on the "V" shape. (The spit has two lugs which should be nearest to the oven door so to stop the spit going forward, the lugs also act as a grip for the handle.)</li> <li>4. Unscrew the handle before cooking.</li> <li>5. After cooking, screw the handle back to help remove the spit from the cradle.</li> </ol>
Divider	<p>The divider is designed to separate the oven in two zones. Use the divider with Dual cook mode. Do not use the divider for any other purpose than dividing the cavity into two cooking zones. Do not use the divider as a shelf.</p>
Telescopic rails *	<p>Use the telescopic rail plate to insert the tray as follows:</p> <ol style="list-style-type: none"> <li>1. Stretch the rail plate out from the oven.</li> <li>2. Put the tray on the rail plate and slide the rail plate into the oven.</li> <li>3. Close the oven door.</li> </ol>

Before you start

## Before you start

Meat probe *	The meat probe measures the internal temperature of the meat to cook. Use only the meat probe that comes with your oven.
Steam container *	<p>The steam container is only for steam assisted modes. Use the steam container on the steam container level only and make sure to insert fully into the cavity so the container touches the rear wall.</p> <p>The steam container has 4 separate parts: Glass lid, metal pan, steam tray, and steam nozzle. The glass lid can be used as baking and gratin dish.</p> <p><b>⚠ WARNING</b></p> <ul style="list-style-type: none"> <li>Always wear oven mittens when handling the steam container and be careful not to drop the steam container.</li> <li>Sudden temperature changes could cause glass parts to break or shatter.</li> </ul>

### NOTE

Availability of accessories with an asterisk (\*) depends on the oven model.

## Water reservoir

The water reservoir is used for steam functions. Fill it with water in advance of steam cooking.

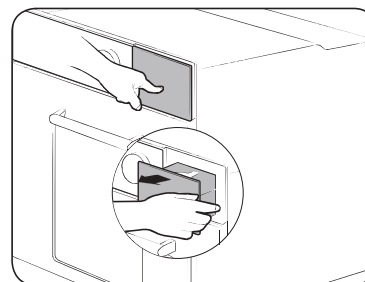

1. Locate the water reservoir in the top-right corner. Push in the reservoir to open and remove.

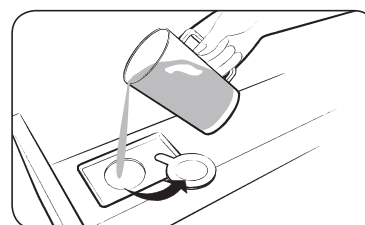

2. Open the reservoir cap, and fill the reservoir with 500 ml of drinkable water.
3. Close the cap, and reinsert the reservoir.

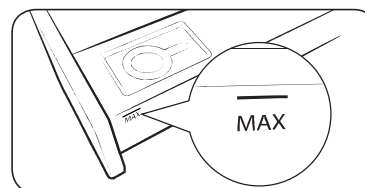

### NOTE

Do not exceed the max line.

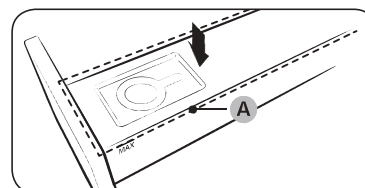

### NOTE

Make sure the upper case (A) of the water reservoir is closed before using the oven.

# Operations

## Oven modes

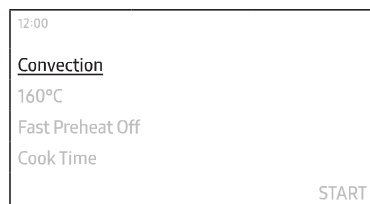

1. On the main screen, select **Convection**, and then press the **Dial Knob**.
2. Select the desired cook mode, and then press the **Dial Knob**. (For detailed information of each mode, see “Oven mode descriptions”.)
  - You can use the meat probe in some modes. To cook using the meat probe, see “Cooking with the meat probe (applicable models only)”.

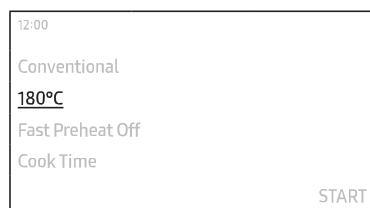

3. Set the desired temperature.
  - The default temperature and the temperature range differ depending on the cook mode.

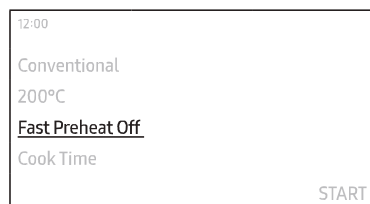

4. Set the Fast Preheat option.
  - The default setting is “Off”.

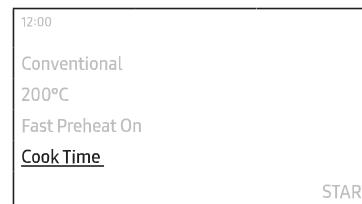

5. Select **Cook Time**, and then press the **Dial Knob** to set the desired cooking time.
  - Maximum cooking time is 23 hours and 59 minutes.
6. After setting the cooking time, select the option you want to run at the end of cooking, and then press the **Dial Knob**.
  - You can select **Oven Off**, **Keep Temp.**, or **Keep Warm**.
  - The Large Grill and Eco Grill modes does not support the **Keep Warm** option.

### NOTE

If you start cooking without setting the cooking time or set **Keep Temp.** for option, you must stop the oven manually.

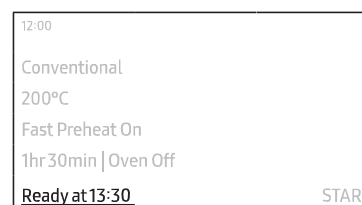

7. Select **Ready at**, and then press the **Dial Knob** to set the desired end time.
  - When you set the cooking time, the oven displays the time cooking will end. (Ex. **Ready at 13:30**)

# Operations

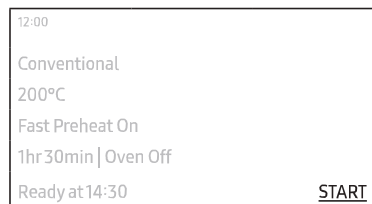







8. Select **START**, and then press the **Dial Knob**.





- If you did not change the end time, the oven starts cooking immediately.
- If you changed the end time, the oven will automatically adjust the start time to end cooking at the set time.

## NOTE

- You can change the temperature, Fast Preheat option, and cooking time during cooking.
- During cooking, you can select **OFF**, press the **Dial Knob**, select **OK**, and then press the **Dial Knob** to cancel cooking.
- When cooking is complete, **+5 mins** appears on the screen.
  - You can select **+5 mins**, and then press the **Dial Knob** to extend the cooking for 5 more minutes.

## Oven mode descriptions

Mode	Temperature range (°C)	Default temperature (°C)	Fast Preheat	Meat probe
 Convection	30-275	160	0	0
	The rear heating element generates heat, which is evenly distributed by the convection fan. Use this mode for baking and roasting on different levels at the same time.			
 Conventional	30-275	180	0	0
	The heat is generated from the top and bottom heating elements. This function should be used for standard baking and roasting for most types of dishes.			
 Large Grill	100-300	220	X	X
	The large-area grill emits heat. Use this mode for browning the tops of food (for example, meat, lasagne, or gratin).			
 Eco Grill	100-300	220	X	X
	The small-area grill emits heat. Use this mode for food that requires less heat, such as fish and filled baguettes.			
 Fan Grill	100-275	180	X	X
	Two top heating elements generate heat, which is distributed by the fan. Use this mode for grilling meat or fish.			
 Top Heat + Convection	40-275	180	0	0
	The top heating element generates heat, which is evenly distributed by the convection fan. Use this mode for roasting that requires a crispy top (for example, meat or lasagne).			

Mode		Temperature range (°C)	Default temperature (°C)	Fast Preheat	Meat probe
	Bottom Heat + Convection	40-275	200	0	0
		The bottom heating element generates heat, which is evenly distributed by the convection fan. Use this mode for pizza, bread, or cake.			
	Bottom Heat	100-230	150	X	X
		The bottom heating element generates heat. Use this mode at the end of baking or cooking to brown the bottoms of a quiche or pizza.			
	Pro-Roasting	80-200	160	X	0
		Pro-Roasting runs an automatic pre-heating cycle until the oven temperature reaches 220 °C. Then, the top heating element and the convection fan start operating to sear food such as meat. After searing, the meat will be cooked at low temperatures. Use this mode for beef, poultry, or fish.			
	Eco Convection	30-275	160	X	0
		Eco Convection uses the optimized heating system to save energy while cooking. The cooking times slightly increases, but the cooking results remain the same. Note that this mode does not require preheating.			
		<p> <b>NOTE</b></p> <p>Eco Convection mode of heating used to determine the energy efficiency class is in accordance with EN60350-1.</p>			

## Steam assisted modes

### CAUTION

Make sure the water reservoir is filled before using the steam assisted modes.

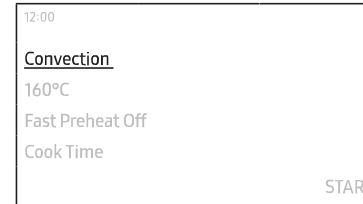

1. On the main screen, select **Convection**, and then press the **Dial Knob**.
2. Select the desired cook mode, and then press the **Dial Knob**. (For detailed information of each mode, see "Steam assisted mode descriptions")
  - If you selected **Steam Cook**, go to step 5. (Step 2-4 is not applicable for **Steam Cook**.)
  - You can use the meat probe in some modes. To cook using the meat probe, see "Cooking with the meat probe (applicable models only)".

### NOTE

**Steam Cook** is available on applicable models only.

3. Set the desired temperature.
  - The default temperature and the temperature range differ depending on the cook mode.

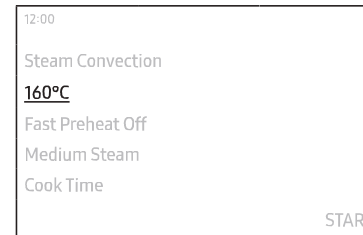

# Operations

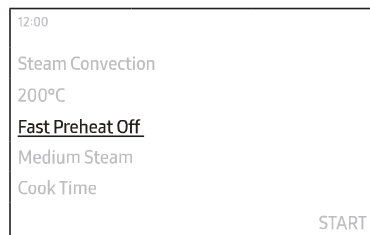

4. Set the Fast Preheat option.
- The default setting is "Off".

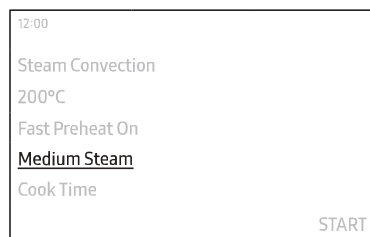

5. Set the steam level.
- The default setting is "Medium".

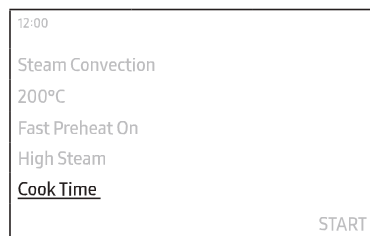

6. Select **Cook Time**, and then press the **Dial Knob** to set the desired cooking time.
- Maximum cooking time is 23 hours and 59 minutes.
7. After setting the cooking time, select the option you want to run at the end of cooking, and then press the **Dial Knob**.
- You can select **Oven Off**, **Keep Temp.**, or **Keep Warm**.

### NOTE

If you start cooking without setting the cooking time or set **Keep Temp.** for option, you must stop the oven manually.

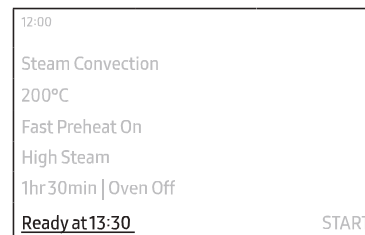

8. Select **Ready at**, and then press the **Dial Knob** to set the desired end time.
- When you set the cooking time, the oven displays the time cooking will end. (Ex. **Ready at 13:30**)

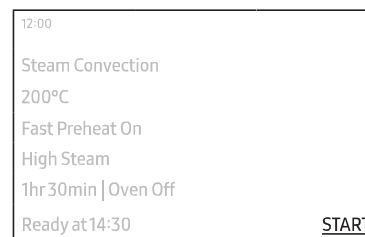





9. Select **START**, and then press the **Dial Knob**.
- If you did not change the end time, the oven starts cooking immediately.
  - If you changed the end time, the oven will automatically adjust the start time to end cooking at the set time.

### NOTE

- You can change the temperature, Fast Preheat option, and cooking time during cooking.
- During cooking, you can select **OFF**, press the **Dial Knob**, select **OK**, and then press the **Dial Knob** to cancel cooking.
- When cooking is complete, **+5 mins** appears on the screen.
  - You can select **+5 mins**, and then press the **Dial Knob** to extend the cooking for 5 more minutes.

## Steam assisted mode descriptions

Mode	Temperature range (°C)	Default temperature (°C)	Fast Preheat	Meat probe	
 Steam Cook *	-	-	X	X	
	The hot steam from the steam generator is injected through the steam nozzle into the oven to cook food. This mode is suitable for cooking vegetables, fish, eggs, fruits, and rice.				
 Steam Convection	120-275	160	0	0	
	The heat generated by the convection heater and fans is continuously supported by hot steam. The intensity of the steam can be adjusted to Low, Medium, or High. This mode is suitable for baking puff pastries, yeast cake, bread, and pizza and roasting meat and fish.				
 Steam Top Heat + Convection	120-275	180	0	0	
	The heat generated by the top heater and the convection heater is shared evenly in the oven by the fan, and the hot steam supports the heating elements. This mode is suitable for roasting crusty dishes like meat, poultry, or fish.				
 Steam Bottom Heat + Convection	120-275	200	0	0	
	The heat generated by the bottom heating element and the convection heater is shared evenly in the oven by the fan, and the hot steam supports the heating elements. This mode is suitable for crispy baking foods like pizza or apple pie.				

### NOTE

- Availability of the modes with an asterisk (\*) depends on the oven model.
- Always fill the water reservoir with fresh water when cooking with these modes.

## Dual cook modes

You can use the provided divider to separate the cooking chamber in the upper and lower zones. This allows users to enable two different cooking modes simultaneously, or to simply choose one zone to cook with.

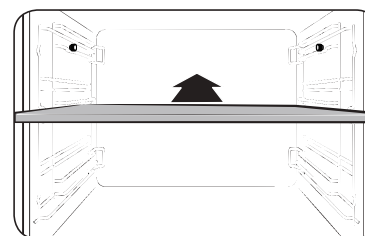

1. Insert the divider in level 3 to separate the cooking chamber in two zones.
  - When the divider is inserted, the oven senses the divider and the main screen changes automatically.

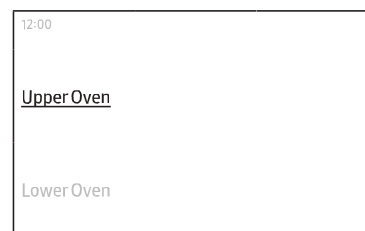

2. Select the desired cooking zone, and then press the **Dial Knob**.

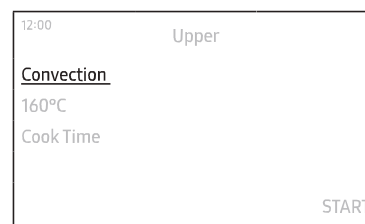

3. Set the desired cooking settings and start cooking.
  - For instructions, see “Oven modes” or “Steam assisted modes”.
  - For available modes and options, refer to “Available modes in each zone”.

# Operations

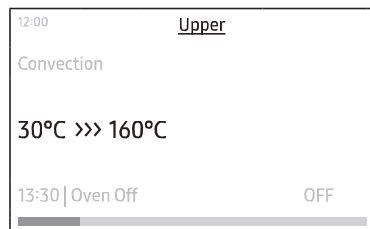

## NOTE

- Once you started cooking in the either zone, you can start cooking in the other zone. Select the zone indicator on the top-middle of the screen, press the **Dial Knob**, and then repeat step 2 to 3 to cook in the other zone.
- There may be some restrictions on modes or temperature range that you can select when you try to cook in the both zones simultaneously.

## Available modes in each zone

Zone	Available mode	Temperature range (°C)	Default temperature (°C)	Fast Preheat	Meat probe
Upper	Convection	40-250	160	X	X
	Large Grill	40-250	220	X	X
	Top Heat + Convection	40-250	180	X	X
Lower	Convection	40-250	160	X	X
	Bottom Heat + Convection	40-250	200	X	X
	Bottom Heat	40-250	150	X	X
	Steam Cook *	-	-	X	X
	Steam Convection	120-250	160	X	X
	Steam Bottom Heat + Convection	120-250	200	X	X

## NOTE

- Refer to "Oven mode descriptions" or "Steam assisted mode descriptions" for description of each mode.
- Availability of the modes with an asterisk (\*) depends on the oven model.

## Cooking with the meat probe (applicable models only)

The meat probe measures the internal temperature of meat while it's cooking. When the temperature reaches the target temperature, the oven stops and finishes cooking.

- Use only the meat probe that comes with your oven.
- You cannot set the cooking time if the meat probe is plugged in.

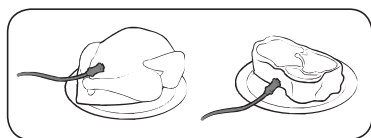

1. Insert the tip of the meat probe into the center of the meat to cook. Make sure the rubber handle is not inserted.

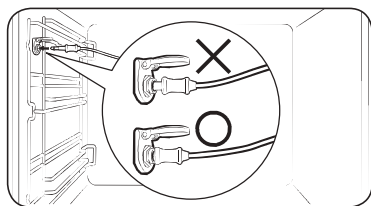

2. Plug the probe connector into the socket on the left wall. If the probe is connected properly, you will see a message of "Meat probe inserted."

- If the meat probe is inserted, **Probe Temperature** will appear instead of **Cook Time**.

3. Select **Probe Temperature**, and then press the **Dial Knob** to set the target temperature of your meat.

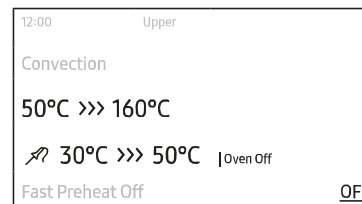
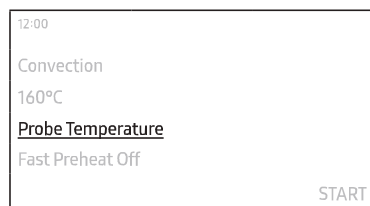

4. Set the desired cooking settings.
  - Refer to "Oven mode descriptions" or "Steam assisted mode descriptions" for the modes you can use the meat probe.
  - Refer to steps 1-3 of "Oven modes" or steps 1-4 of the "Steam assisted modes".
5. Select **START**, and then press the **Dial Knob**.
  - The oven completes cooking with a melody when the internal temperature of the meat reaches the set temperature.

### ⚠ WARNING

- To prevent damage, do not use the meat probe with the spit accessory.
- When cooking is complete, the meat probe becomes very hot. To prevent burns, use oven gloves to take out the food.

### 📖 NOTE

Not all modes support using the meat probe. If you use the meat probe with inapplicable modes, you will see a message of "The selected mode does not support the use of the meat probe.". When this happens, remove the meat probe instantly.

# Operations

## Special Function

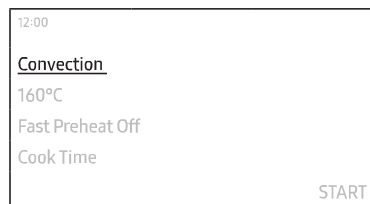

1. On the main screen, select **Convection**, and then press the **Dial Knob**.

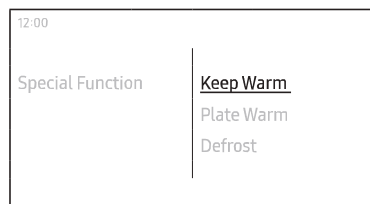

2. Select **Special Function**, and then press the **Dial Knob**.

3. Select the desired function, and then press the **Dial Knob**.

- For detailed information of each function, see “Special Function description”.

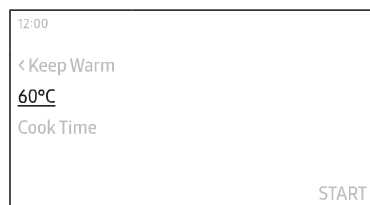

4. Set the desired temperature.

- The default temperature and the temperature differ depending on the cook mode.



5. Select **Cook Time**, and then press the **Dial Knob** to set the desired cooking time, or select **Probe Temperature**, and then press the **Dial Knob** to set the target temperature of your meat.

- **Probe Temperature** is only applicable for **Slow Cook**.
- Maximum cooking time is 23 hours and 59 minutes.

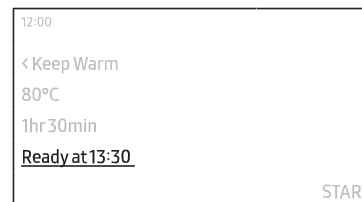

6. Select **Ready at**, and then press the **Dial Knob** to set the desired end time.

- When you set the cooking time, the oven displays the time cooking will end. (Ex. **Ready at 13:30**)
- This step is not applicable for **Slow Cook**.

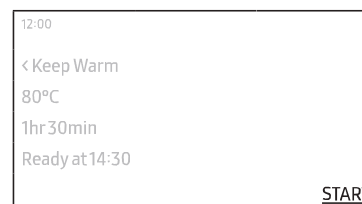

7. Select **START**, and then press the **Dial Knob**.

- If you did not change the end time, the oven starts cooking immediately.
- If you changed the end time, the oven will automatically adjust the start time to end cooking at the set time.
- If you selected **Slow Cook**, the oven completes cooking with a melody when the internal temperature of the meat reaches the set temperature.

### Special Function description

Mode	Temperature range (°C)	Default temperature (°C)	Descriptions
Keep Warm	40-100	60	Use this only for keeping foods warm that have just been cooked.
Plate Warm	30-80	50	Use this for warming dishes or ovenware.
Defrost	30-60	30	This mode uses for defrosting frozen products, baking goods, fruit, cake, cream and chocolate. The defrosting time is depending on the type, size and quantity of the food.
Prove Dough	30-50	35	This mode uses for proving the dough and making the homemade yogurt.
Pizza Cook	160-250	200	This mode is suitable for the pizza and the cooking temperature and time will depend on the pizza size and the thickness of pizza dough.

Mode	Temperature range (°C)	Default temperature (°C)	Descriptions
Slow Cook	70-120	80	This mode uses low temperature for the tender texture. This is suitable for roasting beef, pork, veal or lamb when you want to a tender texture. We recommend searing the meat all over at high temperature on the hob before roasting.
Drying	40-90	60	This mode uses for drying the fruit, vegetable and herb. The drying time is depending on the type and thickness and quantity of the food.

# Operations

## Healthy Cook (applicable models only)

The oven offers 20 healthy cook programs. The cook settings will be adjusted automatically according to the selected programme.

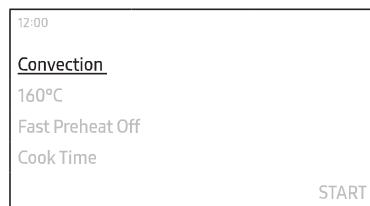

1. On the main screen, select **Convection**, and then press the **Dial Knob**.
2. Select **Healthy Cook**, and then press the **Dial Knob**.

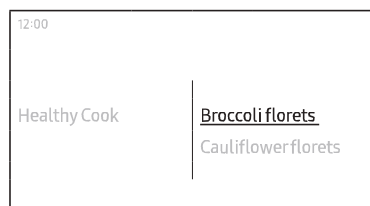

3. Select the desired programme, and then press the **Dial Knob**.
  - For detailed information of each programme, see “Healthy Cook” in “Cooking Smart” section on page 47.)

4. Read the tip, select **Next**, and then press the **Dial Knob**.
5. Pour the water in the water reservoir as instructed on the screen, select **Next**, and then press the **Dial Knob**.
6. Prepare food and accessories as instructed on the screen, select **Next**, and then press the **Dial Knob**.
  - If you want to start cooking at a certain time, select **Delay Start**, and then press the **Dial Knob** to set the desired time.
7. Select **START**, and then press the **Dial Knob**.

## Auto Cook

The oven offers 50 or 70 (for Steam cook model) Auto Cook programmes. Take advantage of this feature to save your time or shorten your learning curve. The cooking time, power level and temperature will be adjusted according to the selected programme.

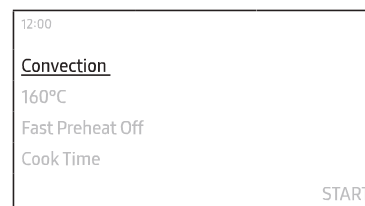

1. On the main screen, select **Convection**, and then press the **Dial Knob**.
2. Select **Auto Cook**, and then press the **Dial Knob**.

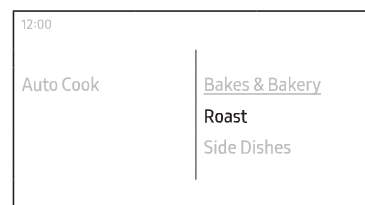

3. Select the category, and then press the **Dial Knob**.
4. Select the subcategory, and then press the **Dial Knob**.
  - Some categories may not have a subcategory.
5. Select the desired programme, and then press the **Dial Knob**.
  - For detailed information of each programme, see “Auto Cook programmes” in “Cooking Smart” section on page 40.)
6. Read the tip, select **Next**, and then press the **Dial Knob**.

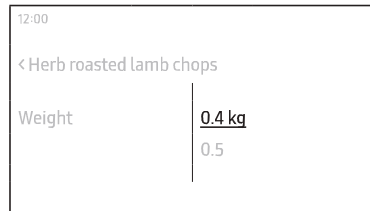

7. Select the weight, and then press the **Dial Knob**.
  - This step may not apply to some programmes.
  - Available weight differs depending on the selected programme.
8. Pour the water in the water reservoir as instructed on the screen, select **Next**, and then press the **Dial Knob**.
  - This step may not apply to some programmes.
9. Prepare food and accessories as instructed on the screen, select **Next**, and then press the **Dial Knob**.
  - If you want to start cooking at a certain time, select **Delay Start**, and then press the **Dial Knob** to set the desired time.
10. Select **START**, and then press the **Dial Knob**.

## Timer

### Adding the new Timer



1. Touch the **≡** button on the control panel.
2. Select **Timer**, and then press the **Dial Knob**.
3. On the Timer screen, select **+**, and then press the **Dial Knob**.
  - Skip this step if you are adding the timer for the first time.
4. Set the time.

### Editing the existing Timer

1. Touch the **≡** button on the control panel.
2. Select **Timer**, and then press the **Dial Knob**.
3. On the Timer screen, select the Timer you want to edit, and then press the **Dial Knob**.
4. Change the time.

# Operations

## Deleting the Timer

1. Touch the  button on the control panel.
2. Select **Timer**, and then press the **Dial Knob**.
3. On the Timer screen, select , and then press the **Dial Knob**.
4. Select **Delete** on the right side of the Timer you want to delete, and then press the **Dial Knob**.
5. Select **Done**, and then press the **Dial Knob**.

## Using the Timer

1. Touch the  button on the control panel.
2. Select **Timer**, and then press the **Dial Knob**.
3. Select **Start** on the right side of the Timer you want to use, and then press the **Dial Knob**.
  - Once you start the timer, you can pause or cancel the timer.

### NOTE

When the time has elapsed to a set point, a message of “Time is up.” appears with a melody. Select **OK**, and then press the **Dial Knob** to dismiss the message.

## Cleaning

### Pyrolytic

Pyrolytic features high temperature thermal cleaning. It burns off oily leftovers to facilitate manual cleaning.

1. Touch the  button on the control panel.
2. Select **Cleaning**, and then press the **Dial Knob**.
3. Select **Pyrolytic**, and then press the **Dial Knob**.
4. Select the time, and then press the **Dial Knob**.
5. Select **Next**, and then press the **Dial Knob**.
6. Follow the instruction on the screen, select **Next**, and then press the **Dial Knob**.
7. Read the message on the screen, select **Start**, and then press the **Dial Knob**.
8. Wait until the oven cools down, and then wipe the door along its edges using a wet cloth.

### CAUTION

- Do not touch the oven because the oven becomes very hot during the cycle.
- To avoid accidents, keep children away from the oven.
- After the cycle is complete, do not power off while the cooling fan is operating to cool the oven down.

### NOTE

- Once the cycle starts, the oven becomes hot inside. Then, the door will be locked for safety. When the cycle is complete, and the oven cools down, the door will be unlocked.
- Make sure you empty the oven before cleaning. Accessories can be deformed due to high temperatures inside the oven.

## Steam Clean

This is useful for cleaning light soiling with steam. This automatic function saves you time by removing the need for regular manual cleaning.

1. Touch the  button on the control panel.
2. Select **Cleaning**, and then press the **Dial Knob**.
3. Select **Steam Clean**, and then press the **Dial Knob**.
4. Follow the instruction on the screen, select **Next**, and then press the **Dial Knob**.
5. Select **START**, and then press the **Dial Knob**.

### WARNING

Do not open the door before the cycle is complete. The water inside the oven is very hot, and it can cause burns.

### NOTE

- If the oven is heavily soiled with grease, for example, after roasting or grilling, it is recommended to remove stubborn soil manually using a cleaning agent before activating Steam cleaning.
- Leave the oven door ajar when the cycle is complete. This is to allow the interior enamel surface to dry thoroughly.
- While the oven is hot inside, auto cleaning is not activated. Wait until the oven cools down and try again.
- Do not pour water onto the bottom by force. Do it gently. Otherwise, the water overflows to the front.

## Descal

Clean inside the steam generator to prevent affecting the food quality and taste.

### NOTE

- The oven counts the time of steam assisted modes and notifies you to run the Descal function when required. You can still use the steam assisted modes for the next two hours without running the Descal function. However, you cannot use the steam assisted modes after two hours unless you run and complete the Descal function.
  - When you get the notification message, select **Start now**, and then press the **Dial Knob** to run the Descal function, or select **Later**, and then press the **Dial Knob** to postpone it.
1. Touch the  button on the control panel.
  2. Select **Cleaning**, and then press the **Dial Knob**.
  3. Select **Descal**, and then press the **Dial Knob**.
  4. Select **Next**, and then press the **Dial Knob**.
  5. Follow the instruction on the screen, select **Start**, and then press the **Dial Knob**.
    - If you get a notification message that you have insufficient water, add more water in the water reservoir, select **OK**, and then press the **Dial Knob**.
  6. When descaling is complete, the oven drains water automatically.
  7. Once draining is complete, empty the water reservoir.
  8. Refill the water reservoir with 500 ml of drinkable water as instructed on the screen, select **OK**, and then press the **Dial Knob** to start rinsing.
  9. When rinsing is complete, empty the water reservoir.
    - After emptying the reservoir, clean it before putting it back to the oven.
- ### WARNING
- Wear oven gloves when you handle the water reservoir.
  - Use only descaling agents that are specific to steam ovens or coffee machines.

# Operations

## ⚠ CAUTION

- Do not cancel descaling in the process. Otherwise, you must restart the descaling cycle and complete within the next three hours in order to enable steam assisted modes.
- To avoid accidents, keep children away from the oven.
- For the mixture ratio of water and the descaling agent, follow the agent manufacturer's instruction as it precedes.

## Drain

After using the steam assisted modes, you must drain the remaining water to prevent affecting other cooking modes. Also, if you want to drain again for cleaning purposes, use this function.

1. Touch the  button on the control panel.
2. Select **Cleaning**, and then press the **Dial Knob**.
3. Select **Drain**, and then press the **Dial Knob**.
4. Select **Start**, and then press the **Dial Knob**.
5. Follow the instruction on the screen, select **OK**, and then press the **Dial Knob**.
  - The oven drains water from the steam generator to the water reservoir.
6. When draining is complete, empty the water reservoir.
  - After emptying the reservoir, clean it before putting it back to the oven.

## ⚠ WARNING

- Wear oven gloves when you handle the water reservoir.
- Do not remove the water reservoir while draining.

## 📄 NOTE

Once the oven starts draining, please wait until the draining cycle is complete.

## Settings

Touch the  button on the control panel, select **Settings**, and then press the **Dial Knob** to change various settings for your oven. Please refer to the following table for detailed descriptions.



Menu	Submenu	Description
Connections	Wi-Fi	You can turn the Wi-Fi on or off.
	Easy Connection	You can connect the oven to the SmartThings server via a Wi-Fi connection. When the oven is connected, you can use the SmartThings app to check the status of the oven and/or control it from a mobile device.
	Remote management	Select <b>Activate</b> , and then press the <b>Dial Knob</b> to allow the Call Centre to access your oven remotely to check internal information.

Menu	Submenu	Description
Display	Brightness	You can change the brightness of the display screen.
	Screen saver	You can turn the screen saver on or off. <b>NOTE</b> The Screen saver is a function that displays the date and time on your screen if there is no input for a certain time in standby status.
	Clock theme	You can select the clock theme.
	Timeout	You can set the length of time before the screen saver turns on. <b>NOTE</b> <ul style="list-style-type: none"> <li>Energy consumption may increase depending on your setting.</li> <li>When the timeout setting is set to "<b>Always on</b>", the brightness of the LCD automatically changes to level 2 if there is no action for 3 minutes.</li> </ul>
Date & time	Automatic date and time	You can turn on or turn off to update time from the Internet. You must be connected to the Wi-Fi network.
	Select time zone	You can select the time zone. (You must disable Automatic date and time.)
	Set date	You can manually set a date. (You must disable Automatic date and time.)
	Set time	You can manually set time. (You must disable Automatic date and time.)
	Select time format	You can select the time format from 12-hour or 24-hour format.
Language		You can select a language.

Menu	Submenu	Description
Volume		You can adjust the volume of the oven.
Water hardness		You can adjust the water hardness of the water you use for steam assisted modes. <ul style="list-style-type: none"> <li>Soft: Up to 120 ppm</li> <li>Medium: 120-240 ppm</li> <li>Medium-Hard: 240-350 ppm</li> <li>Hard: Over 350 ppm</li> </ul>
Help	Troubleshooting	You can check the troubleshooting.
	Guide for first use	You can check the simple instructions on basic use of the oven.
About device	Model name	You can check the model name of our oven.
	SW version	You can check the current version of the firmware. When you have new software available, <b>SW update</b> button will appear on this menu.
	Legal information	You can check the legal information.
Demo mode		You can turn the Demo mode on or off.

### Lock

You can lock the control panel to prevent any unintended operation.

- To activate the Lock function, touch the  button on the control panel, select **Lock**, and then press the **Dial Knob**.
- To deactivate the Lock function, touch and hold the  button until you see the "Control is unlocked." message.

# Cooking Smart

## Manual cooking

### ⚠ WARNING on acrylamide

Acrylamide produced while baking starch-contained food such as potato chips, French fries, and bread may cause health problems. It is recommended to cook these foods at low temperatures and avoid overcooking, heavy crisping, or burning.

### ⚠ CAUTION

Foods that can easily spoil (such as milk, eggs, fish, meat, or poultry) should not stand in the oven for more than 1 hour before cooking begins, and should be removed promptly when cooking is completed. Eating spoiled food can result in sickness from food poisoning.

### 📖 NOTE

- Pre-heating is recommended for all cooking modes unless otherwise specified in the cooking guide.
- When using Eco Grill, put food in the centre of the accessory tray.













### Accessory tips



Your oven comes with a different number or kind of accessories. You may find that some accessories are missing from the table below. However, even if you are not provided with the exact accessories specified in this cooking guide, you can follow along with what you already have, and achieve the same results.

- The Baking tray and the Universal tray are interchangeable.
- When cooking oily foods, it is recommended to put a tray under the Wire rack to collect oil residue. If you are provided with the Wire rack insert, you can use it together with the tray.
- If you are provided with the Universal tray or Extra deep tray, or both, it is better to use whichever is deeper for cooking oily foods.





## Baking









We recommend to preheat the oven for best results.

Food	Accessory	Level	Type of heating	Temp. (°C)	Time (min.)
Sponge cake	Wire rack, Ø 25-26 cm tin	2		160-170	35-40
Marble cake	Wire rack, Gugelhopf tin	3		175-185	50-60
Tart	Wire rack, Ø 20 cm tart tin	3		190-200	50-60
Yeast cake on tray with fruits and crumbles	Universal tray	2		160-180	40-50
Fruit crumble	Wire rack, 22-24 cm oven dish	3		170-180	25-30
Scones	Universal tray	3		180-190	30-35
Lasagne	Wire rack, 22-24 cm oven dish	3		190-200	25-30
Meringues	Universal tray	3		80-100	100-150
Soufflé	Wire rack, soufflé cups	3		170-180	20-25
Apple yeast tray cake	Universal tray	3		150-170	60-70
Homemade pizza, 1-1.2 kg	Universal tray	2		190-210	10-15
Frozen puff pastry, filled	Universal tray	2		180-200	20-25
Quiche	Wire rack, 22-24 cm oven dish	2		180-190	25-35

Food	Accessory	Level	Type of heating	Temp. (°C)	Time (min.)
Apple pie	Wire rack, Ø 20 cm tin	2		160-170	65-75
Chilled pizza	Universal tray	3		180-200	5-10

### Roasting

Food	Accessory	Level	Type of heating	Temp. (°C)	Time (min.)
<b>Meat (Beef/Pork/Lamb)</b>					
Sirloin of beef, 1 kg	Wire rack + Universal tray	3 1		160-180	50-70
Boned loin of veal, 1.5 kg	Wire rack + Universal tray	3 1		160-180	90-120
Pork roast, 1 kg	Wire rack + Universal tray	3 1		200-210	50-60
Joint of pork, 1 kg	Wire rack + Universal tray	3 1		160-180	100-120
Leg of lamb on the bone, 1 kg	Wire rack + Universal tray	3 1		170-180	100-120









Food	Accessory	Level	Type of heating	Temp. (°C)	Time (min.)
<b>Poultry (Chicken/Duck/Turkey)</b>					
Chicken, whole, 1.2 kg *	Wire rack + Universal tray (to catch drippings)	3 1		200	60-80 *
Chicken pieces	Wire rack + Universal tray	3 1		200-220	25-35
Duck breast	Wire rack + Universal tray	3 1		200-210	20-30
Small turkey, whole, 5 kg	Wire rack + Universal tray	3 1		180-200	120-150
<b>Vegetables</b>					
Vegetables, 0.5 kg	Universal tray	3		220-230	15-20
Baked potato halves, 0.5 Kg	Universal tray	3		190-200	40-50
<b>Fish</b>					
Fish fillet, baked	Wire rack + Universal tray	3 1		200-220	20-30
Roast fish	Wire rack + Universal tray	3 1		180-200	30-40

\* Turn over after ⅓ of cooking time.

# Cooking Smart









## Grilling

We recommend preheat the oven using Large Grill mode. Turn over after half of time.

Food	Accessory	Level	Type of heating	Temp. (°C)	Time (min.)
<b>Bread</b>					
Toast	Wire rack	5		270-300	2-4
Cheese toast	Universal tray	4		200	4-8
<b>Beef</b>					
Steak *	Wire rack + Universal tray	4 1		240-250	15-20
Burgers *	Wire rack + Universal tray	4 1		250-270	13-18
<b>Pork</b>					
Pork chops	Wire rack + Universal tray	4 1		250-270	15-20
Sausages	Wire rack + Universal tray	4 1		260-270	10-15
<b>Poultry</b>					
Chicken, breast	Wire rack + Universal tray	4 1		230-240	30-35
Chicken, drumstick	Wire rack + Universal tray	4 1		230-240	25-30

\* Turnover after 2/3 of the cooking time.

## Frozen ready-meal

Food	Accessory	Level	Type of heating	Temp. (°C)	Time (min.)
Frozen pizza, 0.4-0.6 kg	Wire rack	3		200-220	15-25
Frozen lasagne	Wire rack	3		180-200	45-50
Frozen oven chips	Universal tray	3		220-225	20-25
Frozen croquettes	Universal tray	3		220-230	25-30
Frozen oven camembert	Wire rack	3		190-200	10-15
Frozen baguettes with topping	Wire rack + Universal tray	3 1		190-200	10-15
Frozen fish fingers	Wire rack + Universal tray	3 1		190-200	15-25
Frozen fish burger	Wire rack	3		180-200	20-35

### Steam assisted mode

With steam enabled, the oven generates steam and evenly distributes inside the cooking compartment, covering the whole area every racks and corners. This helps to brown the food, giving a crispy to top and soft, juicy inside.

Fill the reservoir with drinkable water up to max line, and select a steam level that best suits your recipe.

### Steam Convection

We recommend preheat the oven with steam mode for baking.

Food	Accessory	Level	Steam level	Temp. (°C)	Time (min.)
Chilled bread rolls	Universal tray	3	Low	180-190	10-20
Chilled croissants	Universal tray	3	Low	180-190	10-20
White bread loaf	Wire rack, 24 cm loaf cake tin	2	Med	180-190	30-40
Mixed grain bread loaf	Wire rack, 24 cm loaf cake tin	2	Med	180-190	30-40
Puff pastry	Universal tray	3	Low	180-190	15-20
Vanilla flan caramel	Wire rack	3	High	120-130	20-30
Cheese cake	Wire rack	3	Med	150-160	55-65
Baguette *	Universal tray	3	High	180-200	25-35
Frozen self-rising pizza	Universal tray	3	Med	190-210	15-25

\* Baguette is needed the steam only in the beginning of baking. We recommend to use the **Steam Convection** mode for 10 min and use the **Convection** mode with same temperature during remained baking time.

### Steam Top Heat + Convection

We recommend to adjust the cooking mode after half of the cooking time, in order to remove steam for crispy texture. We recommend to use the **Top Heat + Convection** mode or **Convection** mode and keep the temperature.

Food	Accessory	Level	Steam level	Temp. (°C)	Time (min.)
Pork roast with crackling, 1.2 kg	Wire rack + Universal tray	3 1	Med	170-180	90-120
Chicken, whole, 1.2 kg	Wire rack + Universal tray	2 1	Med	190-200	55-65
Chicken pieces	Wire rack + Universal tray	4 1	Low	210-220	25-35
Duck breast	Wire rack + Universal tray	4 1	Low	170-180	15-25
Duck, whole, 2.5 kg	Wire rack + Universal tray	2 1	Med	170-180	100-120
Small turkey, whole, 4.0 kg	Wire rack + Universal tray	2 1	Med	180-200	120-150
Whole fish, 0.5 kg *	Wire rack + Universal tray	4 1	Med	170-190	20-30
Fish fillets *	Wire rack + Universal tray	4 1	Low	190-200	15-25

\* We recommend to use the **Steam Top Heat + Convection** mode during cooking time for moist texture.

# Cooking Smart

## Steam Bottom Heat + Convection

We recommend to preheat the oven with steam mode for crispy baking.

Food	Accessory	Level	Steam level	Temp. (°C)	Time (min.)
Homemade pizza	Universal tray	2	Med	190-200	15-20
Self-rising pizza	Universal tray	2	Med	190-210	15-20
Quiche	Wire rack	2	Low	180-190	25-35
Bread rolls	Universal tray	2	Low	180-190	15-25
Focaccia	Wire rack	2	Low	200-210	15-25

## Steam Cook (applicable models only)

This **Steam Cook** mode allows you to use of a wide range of recipes.

Be sure to use steam container for steam cook and fill the reservoir with drinkable water up to max line.

Food	Accessory	Level	Time (min.)
Broccoli florets	Steam container	A	10-15
Sliced vegetables (Courgette, carrot, bell pepper)	Steam container	A	10-20
Green asparagus	Steam container	A	15-20
White asparagus	Steam container	A	15-20
Green beans	Steam container	A	15-20
Brussel sprouts	Steam container	A	15-20
Peeled potato halves	Steam container	A	25-35
Fish fillet	Steam container	A	15-25
Mussels	Steam container	A	10-20
Prawns	Steam container	A	10-20
Chicken breast	Steam container	A	20-30
Boiled eggs	Steam container	A	13-18

## NOTE

Level A refers to an exclusive rack for the steam container. See the **Accessories** section on page **14** for exact location of the level A.

## Pro-Roasting

This mode includes an automatic heating-up cycle up to 220 °C. The top heater and the convection fan are operating during the process of searing the meat. After this stage the food is cooked gently by the low temperature of pre-selection. This process is done while the top and the bottom heaters are operating. This mode is suitable for meat roasts and poultry.







Food	Accessory	Level	Temp. (°C)	Time (hrs.)
Roast beef	Wire rack + Universal tray	3 1	80-100	3-4
Pork roast	Wire rack + Universal tray	3 1	80-100	4-5
Lamb roast	Wire rack + Universal tray	3 1	80-100	3-4
Duck breast	Wire rack + Universal tray	3 1	80-100	2-3





### Dual cook

Before using dual cook function insert the divider into the oven. We recommend preheat the oven for best results.

The following table presents 5 dual cook guides we recommend for cooking, roasting and baking. Using dual cook function, you will be able to cook your main dish & side dish or main dish & dessert simultaneously.

- Using dual cook function, preheating time can be extended.

No.	Zone	Food	Accessory	Level	Type of heating	Temp. (°C)	Time (min.)
1	Upper	Sponge cake	Wire rack, Ø 25-26 cm tin	4		160-170	40-45
	Lower	Homemade pizza, 1.0-1.2 kg	Universal tray	1		190-210	13-18
2	Upper	Roast vegetables, 0.4-0.8 kg	Universal tray	4		220-230	13-18
	Lower	Apple pie	Wire rack, Ø 20 cm tin	1		165-175	70-80
3	Upper	Pita bread	Universal tray	4		230-240	13-18
	Lower	Potato gratin, 1.0-1.5 kg	Wire rack, 22-24 cm oven dish	1		180-190	45-50

No.	Zone	Food	Accessory	Level	Type of heating	Temp. (°C)	Time (min.)
4	Upper	Chicken, drumstick	Wire rack + Universal tray	4 4		230-250	30-35
	Lower	Lasagne, 1.0-1.5 kg	Wire rack, 22-24 cm oven dish	1		190-200	30-35
5	Upper	Fish fillet, baked	Wire rack + Universal tray	4 4		210-230	15-20
	Lower	Apple puff pastry	Universal tray	1		170-180	25-30

# Cooking Smart

You can also use upper or lower zone only to save power. The cooking time can be extended when you use separated zone. We recommend preheat the oven for best results.

## Upper

Food	Accessory	Level	Type of heating	Temp. (°C)	Time (min.)
Potato gratin	Wire rack, 22-24 cm oven dish	4		160-170	40-50
Scones	Universal tray	4		180-190	30-35
Lasagne	Wire rack, 22-24 cm oven dish	4		180-190	25-35
Chicken, drumstick *	Wire rack + Universal tray	4 4		230-250	30-35

\* Do not preheat the oven.

## Lower

Food	Accessory	Level	Type of heating	Steam level	Temp. (°C)	Time (min.)
Dutch loaf cake	Wire rack, 24 cm loaf cake tin	1		-	170-180	50-60
Apple pie	Wire rack, Ø 20 cm tin	1		-	160-170	70-80
Homemade pizza, 1.0-1.2 kg	Universal tray	1		-	190-210	15-20
Croissants	Universal tray	1		Low	180-190	15-20

Food	Accessory	Level	Type of heating	Steam level	Temp. (°C)	Time (min.)
Cheese cake	Wire rack	1		Med	150-160	60-70
Bread rolls	Universal tray	1		Low	180-190	15-25
Broccoli florets *	Steam container	A		-	-	10-15
Peeled potato halves *	Steam container	A		-	-	25-35
Fish fillet *	Steam container	A		-	-	15-25
Boiled eggs *	Steam container	A		-	-	13-18

## NOTE

- Level A refers to an exclusive rack for the steam container. See the **Accessories** section on page **14** for exact location of the level A.
- Availability of the cook modes depends on the oven model.

### Eco Convection

This mode uses the optimized heating system so that you save the energy during cooking your dishes. The times of this category are suggested to not be preheated before cooking for saving more energy.

Food	Accessory	Level	Temp. (°C)	Time (min.)
Fruit crumble, 0.8-1.2 kg	Wire rack, 24 cm oven dish	2	160-180	60-80
Jacket potatoes, 0.4-0.8 kg	Universal tray	2	190-200	70-80
Sausages, 0.3-0.5 kg	Wire rack + Universal tray	3 1	160-180	20-30
Frozen oven chips, 0.3-0.5 kg	Universal tray	3	180-200	25-35
Frozen potato wedges, 0.3-0.5 kg	Universal tray	3	190-210	25-35
Fish fillets, baked, 0.4-0.8 kg	Wire rack + Universal tray	3 1	200-220	30-40
Crispy fish fillets, breaded, 0.4-0.8 kg	Wire rack + Universal tray	3 1	200-220	30-45
Roast sirloin of beef, 0.8-1.2 kg	Wire rack + Universal tray	2 1	180-200	65-75
Roast vegetables, 0.4-0.6 kg	Universal tray	3	200-220	25-35

### Meat probe

Type of food		Core temperature (°C)
Beef/Lamb	Rare	45-50
	Medium	55-60
	Well done	65-70
Pork		80-85
Poultry		85-90

# Cooking Smart

## Auto Cook programmes

### ⚠ CAUTION

Foods that can easily spoil (such as milk, eggs, fish, meat, or poultry) should not stand in the oven for more than 1 hour before cooking begins, and should be removed promptly when cooking is completed. Eating spoiled food can result in sickness from food poisoning.

### Single cook

The following table presents 50 auto programmes for cooking, roasting and baking.

It contains its quantities, weight ranges and appropriate recommendations. Cooking modes and times have been pre-programmed for your convenience. You will find some recipes for the auto programmes in your instruction book.

### ⚠ WARNING

Always use oven gloves while taking out food.

### 1. Bakes & Bakery

The Auto Cook programmes include preheating during baking and display the preheating progress. Start programme, after preheating beep sounds, insert food. Always use oven gloves while taking out food.

We recommend the 22-24 cm ovenproof dish which can resist the heat (up to 300 °C) and made from glass or glass ceramic.

Food	Weight (kg)	Accessory	Level
<b>Bakes</b>			
Potato gratin	1.0-1.5	Wire rack	3
	Prepare fresh potato gratin using an ovenproof dish, 22-24 cm. Start programme, after preheating beep sounds, put dish on the centre of rack.		

Food	Weight (kg)	Accessory	Level
Vegetable gratin	0.8-1.2	Wire rack	3
	Prepare fresh vegetable gratin using an ovenproof dish, 22-24 cm. Start programme, after preheating beep sounds, put dish on the centre of rack.		
Pasta bake	1.2-1.5	Wire rack	3
	Prepare pasta gratin using 22-24 cm ovenproof dish. Start programme, after preheating beep sounds, put dish on the centre of rack.		
Lasagne	1.0-1.5	Wire rack	3
	Prepare homemade lasagna using 22-24 cm ovenproof dish. Start programme, after preheating beep sounds, put dish on the centre of rack.		
Ratatouille	1.2-1.5	Wire rack	3
	Put ingredients for Ratatouille in casserole dish with lid. Start programme, after preheating beep sounds, put dish on the centre of rack. Bake covered. Stir before serving.		
<b>Pies &amp; Pastry</b>			
Apple pie	1.2-1.4	Wire rack	2
	Prepare apple pie using a 20-24 cm round metal baking tin. Start programme, after preheating beep sounds, put tin on the centre of rack.		
Croissants *	0.3-0.4	Universal tray	3
	Prepare croissants (chilled ready dough). Put on baking paper on universal tray. Start programme, after preheating beep sounds, put tray into the oven.		

Food	Weight (kg)	Accessory	Level
Apple puff pastry *	0.3-0.4	Universal tray	3
	Put apple puff pastries on baking paper on universal tray. Start programme, after preheating beep sounds, put tray into the oven.		
Fruit flan base	0.4-0.5	Wire rack	3
	Put the dough into a black metal buttered baking dish for cake base. Start programme, after preheating beep sounds, put tin on the centre of rack.		
Quiche Lorraine	1.2-1.5	Wire rack	2
	Prepare quiche dough, put in a round quiche dish with 22-24 cm diameter. Start programme, after preheating beep sounds add filling and put dish on the centre of rack.		
Madeleines	0.2-0.4	Wire rack	3
	Put dough into black metal madeleine moulds. Start programme, after preheating beep sounds add filling and put dish on the centre of rack.		
<b>Bread</b>			
White bread loaf *	0.6-0.7	Wire rack	2
	Prepare dough and put into a black metal rectangular baking dish (length 25-30 cm). Start programme, after preheating beep sounds put dish on the centre of rack.		
Mixed grain bread loaf *	0.8-0.9	Wire rack	2
	Prepare dough and put into a black metal rectangular baking dish (length 25-30 cm). Start programme, after preheating beep sounds put dish on the centre of rack.		
Baguettes *	0.6-0.7	Universal tray	3
	Prepare dough as 2 pieces and put on the universal tray.		

Food	Weight (kg)	Accessory	Level
Walnut bread *	1.0-1.1	Universal tray	3
	Prepare dough as 4 pieces and distribute on the universal tray.		
Bread roll *	0.3-0.5	Universal tray	3
	Prepare rolls (chilled ready dough). Put on baking paper on universal tray. Start programme, after preheating beep, put tray into the oven.		
<b>Cakes &amp; Desserts</b>			
Fruit crumbles	0.8-1.2	Wire rack	3
	Put fresh fruits (raspberries, blackberries, apple slices, or pear slices) into oven dish 22-24 cm. Distribute crumbles on top. Start programme, after preheating beep sounds, put dish on the centre of rack.		
Scones	0.5-0.6	Universal tray	3
	Put scones (5-6 cm diameter) on baking paper on universal tray. Start programme, after preheating beep sounds, put tray into the oven.		
Sponge cake	0.5-0.6	Wire rack	3
	Prepare cake batter and put into a black metal round baking tin with 25-26 cm diameter. Start programme, after preheating beep sounds, put tin on the centre of rack.		
Marble cake	0.7-0.8	Wire rack	2
	Prepare cake batter and put into a metal round gugelhupf or bundt tin. Start programme, after preheating beep sounds, put tin on the centre of rack.		

# Cooking Smart

Food	Weight (kg)	Accessory	Level
Dutch loaf cake	0.7-0.8	Wire rack	2
	Prepare cake batter and put into a black metal rectangular baking dish (length 25-26 cm). Start programme, after preheating beep sounds, put tin on the centre of rack.		
Cheesecake *	0.8-0.9	Wire rack	2
	Prepare dough and put into a black metal round baking tin (20-24 cm). Start programme, after preheating beep sounds, put tin on the centre of rack.		
Brownies	0.7-0.8	Wire rack	3
	Prepare cake batter using a 22-24 cm ovenproof dish. Start programme, after preheating beep sounds, put dish on the centre of rack.		

\* Fill the reservoir with drinkable water up to max line for steam assisted cooking.

## 2. Roast

We recommend fresh chilled meat, poultry and fish for better taste. We recommend thawing frozen ingredients thoroughly if you use the them. The auto programmes don't include the preheating and turning over. But you can turn over after half time for better results if you want.

Food	Weight (kg)	Accessory	Level
<b>Meat</b>			
Roast sirloin of beef **	0.8-2.0	Wire rack	2
		Universal tray	1
Season the beef and leave in refrigerator for 1 hour. Put on the wire-rack with fat-side up.			
Slow cooked roast beef **	0.8-2.0	Wire rack	2
		Universal tray	1
Season the beef and leave in refrigerator for 1 hour. Put on the wire-rack with fat-side up.			
Herb roasted lamb chops	0.4-0.8	Wire rack	4
		Universal tray	1
Marinate the lamb chops with herbs and spices and put them on wire rack.			
Leg of lamb on the bone **	0.8-2.0	Wire rack	3
		Universal tray	1
Marinate the lamb and put on wire rack.			
Roast pork with crackling **	0.8-2.0	Wire rack	3
		Universal tray	1
Put pork roast with fat side to the top on wire rack.			
Rack of pork ribs	0.8-1.2	Wire rack	3
		Universal tray	1
Put rack of pork rib on rack.			

Food	Weight (kg)	Accessory	Level
<b>Poultry</b>			
Chicken, whole */**	0.8-1.5	Wire rack	2
		Universal tray	1
	Rinse and clean chicken. Brush chicken with oil and spices. Put it breast side down on the rack. Put the meat probe into the thickest area of breast.		
Chicken, breast	0.5-0.9	Wire rack	4
		Universal tray	1
	Marinate breast and put on the rack.		
Chicken drumstick	0.5-0.9	Wire rack	4
		Universal tray	1
	Brush with oil and spices and put on rack.		
Butterfly chicken *	1.0-1.3	Wire rack	3
		Universal tray	1
	Rinse and clean chicken. Cut the back of chicken and brush chicken with oil and spices. Put it on wire rack and universal tray and then cook.		
Duck, whole */**	1.5-2.7	Wire rack	2
		Universal tray	1
	Rinse and clean duck. Brush duck with spices. Put it breast side up on the wire rack and universal tray. Put the meat probe into the thickest area of breast.		
Duck, breast	0.3-0.7	Wire rack	4
		Universal tray	1
	Put duck breast with fat-side up on the rack.		

Food	Weight (kg)	Accessory	Level
<b>Fish</b>			
Trout fillet, baked	0.3-0.7	Universal tray	4
		Put trout fillets with the skin side up on the universal tray.	
Trout	0.3-0.7	Wire rack	4
		Universal tray	1
	Rinse and clean the fish and put head to tail on the rack. Add lemon juice, salt and herbs inside fish. Cut skin surface with knife. Brush oil and salt.		
Sole	0.3-0.7	Universal tray	3
		Put sole on baking paper on the universal tray. Cut surface with knife.	
Salmon steak/fillet	0.3-0.7	Wire rack	4
		Universal tray	1
	Rinse and clean fillets or steaks. Put fillets skin side up on rack.		

\* Fill the reservoir with drinkable water up to max line for steam assisted cooking.

\*\* Use the meat probe into the thickest part of meat.

# Cooking Smart

## 3. Side Dishes

The auto programmes don't include the preheating. Use the fresh vegetables.

Food	Weight (kg)	Accessory	Level
Roast vegetables	0.3-0.7	Universal tray	4
	Rinse and prepare slices of courgette, aubergine, pepper, onion and cherry tomatoes. Brush with olive oil, herbs and spices. Distribute evenly on tray.		
Stuffed tomatoes	0.3-0.7	Universal tray	3
	Rinse and cut the tomatoes into halves, core them. Stuff with mixtures (e.g. rice, minced beef) and put it on tray.		
Potato wedges	0.3-0.7	Universal tray	3
	Rinse and cut potatoes into wedges. Brush with olive oil, herbs and spices. Distribute evenly on tray and cook.		
Baked potato halves	0.5-0.9	Universal tray	3
	Cut large potatoes (each 200 g) into halves lengthways. Put with cut side up on universal tray and brush with olive oil, herbs and spices.		

## 4. Convenience

The auto programmes don't include the preheating. Use the frozen pre-cooked conveniences.

Food	Weight (kg)	Accessory	Level
Frozen oven chips	0.3-0.7	Universal tray	3
	Distribute frozen oven chips evenly on tray.		
Frozen potato wedges	0.3-0.7	Universal tray	3
	Distribute frozen potato wedges evenly on tray.		
Frozen lasagne	0.3-0.7	Wire rack	3
	Put the frozen lasagne in the oven dish and put on the wire rack.		

## 5. Pizza & Dough

The Auto Cook programmes include preheating during baking and display the preheating progress. Start programme, after preheating beep sounds, insert food. Always use oven gloves while taking out food.

Food	Weight (kg)	Accessory	Level
Frozen pizza	0.3-0.7	Wire rack	3
	Start programme, after preheating beep sounds, put the frozen pizza on the middle of the wire rack.		
Homemade pizza	0.8-1.2	Universal tray	2
	Prepare homemade pizza with the yeast dough and put it on the universal tray. The weight include dough and topping such as sauce, vegetables, ham and cheese. Start programme, after preheating beep sounds, put tray into the oven.		
Calzone	0.8-1.2	Universal tray	3
	Prepare 4 pieces of fresh calzone and put it on tray.		
Dough proofing	0.3-0.7	Wire rack	2
	Prepare dough in bowl, cover with cling film. Put in centre of rack.		

## Dual cook

The following table presents 20 auto programmes for cooking, roasting and baking. You can use only upper cavity or lower cavity and use the upper and lower cavity at the same time.

The programme contains its quantities, weight ranges and appropriate recommendations. Cooking modes and times have been pre-programmed for your convenience. You will find some recipes for the auto programmes in your instruction book.

All dual Auto Cook programmes include preheating and display the preheating progress.

Please put the food in the oven after preheating beep.

### WARNING

Always use oven gloves while taking out food.

#### 1. Upper

Food	Weight (kg)	Accessory	Level
Potato gratin	1.0-1.5	Wire rack	4
	Prepare fresh potato gratin using an ovenproof dish, 22-24 cm. Start programme, after preheating beep sounds, put dish on the centre of rack.		
Pasta bake	1.2-1.5	Wire rack	4
	Prepare pasta gratin using 22-24 cm ovenproof dish. Start programme, after preheating beep sounds, put dish on the centre of rack.		
Lasagne	1.0-1.5	Wire rack	4
	Prepare homemade lasagna using 22-24 cm ovenproof dish. Start programme, after preheating beep sounds, put dish on the centre of rack.		

# Cooking Smart

Food	Weight (kg)	Accessory	Level
Scones	0.5-0.6	Universal tray	4
	Put scones (5-6 cm diameter) on baking paper on universal tray. Start programme, after preheating beep sounds, put tray into the oven.		
Chicken drumstick	0.5-0.9	Wire rack	4
		Universal tray	4
Brush with oil and spices and put on rack.			
Salmon steak/fillet	0.3-0.7	Wire rack	4
		Universal tray	4
Rinse and clean fillets or steaks. Put fillets skin side up on rack.			
Roast vegetables	0.3-0.7	Universal tray	4
	Rinse and prepare slices of courgette, aubergine, pepper, onion and cherry tomatoes. Brush with olive oil, herbs and spices. Distribute evenly on tray.		
Baked potato halves	0.5-0.9	Universal tray	4
	Cut large potatoes (each 200 g) into halves lengthways. Put with cut side up on universal tray and brush with olive oil, herbs and spices.		
Frozen potato wedges	0.3-0.7	Universal tray	4
	Distribute frozen potato wedges evenly on tray.		
Frozen oven chips	0.3-0.7	Universal tray	4
	Distribute frozen oven chips evenly on tray.		

## 2. Lower

Food	Weight (kg)	Accessory	Level
Apple pie	1.2-1.4	Wire rack	1
	Prepare apple pie using a 20-24 cm round metal baking tin. Start programme, after preheating beep sounds, put tin on the centre of rack.		
Apple puff pastry *	0.3-0.4	Universal tray	1
	Put apple puff pastries on baking paper on tray. Start programme, after preheating beep sounds, put tray into the oven.		
Croissants *	0.3-0.4	Universal tray	1
	Prepare croissants (chilled ready dough). Put on baking paper on universal tray. Start programme, after preheating beep sounds, put tray into the oven.		
Quiche Lorraine	1.2-1.5	Wire rack	1
	Prepare quiche dough, put in a round quiche dish with 22-24 cm diameter. Start programme, after preheating beep sounds add filling and put dish on the centre of rack.		
Bread roll *	0.3-0.5	Universal tray	1
	Prepare rolls (chilled ready dough). Put on baking paper on universal tray. Start programme, after preheating beep, put tray into the oven.		
Fruit crumbles	0.8-1.2	Wire rack	1
	Put fresh fruits (raspberries, blackberries, apple slices, or pear slices) into oven dish 22-24 cm. Distribute crumbles on top. Start programme, after preheating beep sounds, put dish on the centre of rack.		

Food	Weight (kg)	Accessory	Level
Cheesecake *	0.8-0.9	Wire rack	1
	Prepare dough and put into a black metal round baking tin (20-24 cm). Start programme, after preheating beep sounds, put tin on the centre of rack.		
Stuffed tomatoes	0.3-0.7	Universal tray	1
	Rinse and cut the tomatoes into halves, core them. Stuff with mixtures (e.g. rice, minced beef) and put it on tray.		
Frozen pizza	0.3-0.7	Wire rack	1
	Start programme, after preheating beep sounds, put the frozen pizza on the middle of the wire rack.		
Homemade pizza	0.8-1.2	Universal tray	1
	Prepare homemade pizza with the yeast dough and put it on the universal tray. The weight include dough and topping such as sauce, vegetables, ham and cheese. Start programme, after preheating beep sounds, put tray into the oven.		

\* Fill the reservoir with drinkable water up to max line for steam assisted cooking.

### 3. Twin

You can select one auto programme for the lower and upper cavity and cook simultaneously.

#### **⚠ CAUTION**

When you use either the upper or lower cavity, the fan and the heater of the other cavity may operate for optimal performance. The cavity that is not being used must not be used for any unintended purposes.

### Healthy Cook (applicable models only)

The oven offers 20 healthy cook programmes. The cook settings will be adjusted automatically according to the selected programme. You can use single cavity or lower cavity.

Be sure to use steam container for steam cook and fill the reservoir with drinkable water up to max line.

#### **⚠ WARNING**

Always use oven gloves while taking out food.

Food	Weight (kg)	Accessory	Level
Broccoli florets	0.4-0.6	Steam containers	A
Cauliflower florets	0.4-0.6	Steam containers	A
Carrot slices	0.4-0.6	Steam containers	A
Courgette slices	0.4-0.6	Steam containers	A
Pumpkin cubes	0.4-0.6	Steam containers	A
Green asparagus	0.4-0.6	Steam containers	A
White asparagus	0.4-0.6	Steam containers	A
Green beans	0.4-0.6	Steam containers	A
Brussels sprouts	0.4-0.6	Steam containers	A
Peeled potato halves	0.6-0.8	Steam containers	A
Apple slices	0.4-0.6	Steam containers	A
Prawns	0.6-0.8	Steam containers	A
Mussels	0.8-1.0	Steam containers	A
Fish fillet	0.6-0.8	Steam containers	A
Chicken breast	0.8-1.0	Steam containers	A
Crème caramel	0.3-0.4	Steam containers	A

# Cooking Smart

Food	Weight (kg)	Accessory	Level
Frozen dumplings	0.4-0.6	Steam containers	A
Egg, hard-boiled	0.5-0.7	Steam containers	A
Egg, medium-boiled	0.5-0.7	Steam containers	A
Egg, soft-boiled	0.5-0.7	Steam containers	A

**NOTE**

Level A refers to an exclusive rack for the steam container. See the **Accessories** section on page **14** for exact location of the level A.

## Special Function

### Defrost

This mode is used for defrosting frozen products, baking goods, fruit, cake, cream and chocolate. The defrosting time is depending on the type, size and quantity of the food.

Food	Accessory	Level	Temp. (°C)	Time (min.)
Frozen products	Wire rack + Universal tray	3	50	-
Chicken nuggets, Sausage, potatoes		1		
Baked goods	Wire rack + Universal tray	3	50	-
Bread and bread rolls		1		
Fruit	Wire rack, oven dish	3	30	-
Cake, cream, chocolate	Wire rack, oven dish	3	30	-

### Drying

This mode is used for drying the fruit, vegetable and herb. The drying time is depending on the type and thickness and quantity of the food.

Food	Accessory	Level	Temp. (°C)	Time (min.)
Fruit	Wire rack	3	70-80	300-420
Vegetable	Wire rack	3	70-80	200-500
Herb	Wire rack	3	70-80	60-90

### Prove Dough

This mode is used for proving the dough and making the homemade yogurt.

Food	Accessory	Level	Temp. (°C)	Time (min.)
Pizza dough	Wire rack	2	30-40	30-40
Cake/Bread dough	Wire rack, oven dish	2	30-40	40-50
Homemade yogurt	Wire rack, oven dish	2	40-50	6-7 (hours)

## Pizza Cook

This mode is suitable for pizza. Cooking temperature and time will depend on the pizza size and the thickness of pizza dough.

Food	Accessory	Level	Temp. (°C)	Time (min.)
Homemade pizza	Universal tray	2	190-210	15-25
Homemade thin pizza	Universal tray	2	210-230	10-15

## Slow Cook

This mode uses the low-temperature for the tender texture. This mode is suitable for roasting beef, pork, veal or lamb when you want to a tender texture. We recommend sear the meat all over at high temperature on the hob before roasting.









Food	Accessory	Level	Temp. (°C)	Time (hours)
Roast beef	Wire rack + Universal tray	3 1	80-100	3-4
Sirloin, 5-6 cm thick	Wire rack + Universal tray	3 1	70-80	4-5
Pork roast	Wire rack + Universal tray	3 1	80-100	4-5
Lamb roast	Wire rack + Universal tray	3 1	80-100	3-4
Duck breast	Wire rack + Universal tray	3 1	70-90	2-3

## Test dishes

According to standard EN 60350-1.

### 1. Baking

The recommendations for baking refer to a preheated oven. Do not use the Fast Preheat function. Always put trays the slanted side to the door front.

Type of food	Accessory	Level	Type of heating	Temp. (°C)	Time (min.)
Small cakes	Universal tray	3		165	23-28
		3		165	25-30
		1+3		155	33-38
Shortbread	Universal tray	1+3		140	28-33
Fatless sponge cake	Wire rack + Spring form cake tin (Dark coated, Ø 26 cm)	2		165	30-35 *
		2		160	30-35
		1+4		155	35-40
Apple pie	Wire rack + 2 Spring form cake tins ** (Dark coated, Ø 20 cm)	2, placed diagonally		160	70-80
	Universal tray + Wire rack + 2 Spring form cake tins *** (Dark coated, Ø 20 cm)	1+3		160	80-90

\* Increase the cooking time by 5 minutes if you are cooking in Conventional mode using a glass ovenware (Ø 26 cm).



\*\* Two cakes are arranged on the grid at the back left and at the front right.

\*\*\* Two cakes are arranged in the center on top of each other.

# Cooking Smart



## 2. Grilling

Preheat the empty oven for 5 minutes using Large Grill function.

Type of food	Accessory	Level	Type of heating	Temp. (°C)	Time (min.)
White bread toast	Wire rack	5		300 (Max.)	1-2
Beef burgers * (12 ea)	Wire rack + Universal tray (to catch drippings)	4 1		300 (Max.)	1 <sup>st</sup> 15-18 2 <sup>nd</sup> 5-8

\* Turn over after  $\frac{2}{3}$  of the cooking time.





## 3. Roasting

Type of food	Accessory	Level	Type of heating	Temp. (°C)	Time (min.)
Whole chicken * 1.3-1.5 kg	Wire rack + Universal tray (to catch drippings)	3 1		200	60-75
Whole chicken * 1.5-1.7 kg	Wire rack + Universal tray (to catch drippings)	3 1		200	70-85

\* Turn over after half of time.

## 4. Steam cook

Fill the reservoir with drinkable water up to max line for steam cooking.

Type of food	Accessory	Level	Type of heating	Time (min.)
Broccoli florets 0.5 kg	Steam container	A		12-15
Steamed eggs 10 ea	Steam container	A		15-18
Peeled potatoes 0.5 kg	Steam container	A		18-23
Frozen salmon	Steam container	A		18-23

### NOTE

Level A refers to an exclusive rack for the steam container. See the **Accessories** section on page **14** for exact location of the level A.

---

## Collection of frequent Auto Cook recipes

---

### Potato gratin

**Ingredients** 800 g potatoes, 100 ml milk, 100 ml cream, 50 g beaten whole egg, 1 tbsp each of salt, pepper, nutmeg, 150 g grated cheese, butter, thyme.

**Directions** Peel potatoes and slice them to 3 mm thickness. Rub the butter all over the surface of a gratin dish (22-24 cm). Spread the slices on a clean towel and keep them covered with the towel while you prepare the rest of the ingredients.

Mix the rest of the ingredients except for grated cheese into a large bowl and stir well. Layer the potato slices in the dish slightly overlapping and pour the mixture over the potatoes. Spread the grated cheese over the top and bake. After cooking, serve sprinkled with a few fresh thyme leaves.

### Vegetable gratin

**Ingredients** 800 g vegetables (courgette, tomato, onion, carrot, pepper, pre-cooked potatoes), 150 ml cream, 50 g beaten whole egg, 1 tbsp each of salt, herb (pepper, parsley or rosemary), 150 g grated cheese, 3 tbsp olive oil, Some thyme leaves.

**Directions** Wash the vegetables and slice them to 3-5 mm thickness. Layer the slices on a gratin dish (22-24 cm) and pour the oil on the vegetables. Mix the rest of the ingredients except for grated cheese and pour on the vegetables. Spread the grated cheese over the top and bake. Then serve sprinkled with a few fresh thyme leaves.

---

### Lasagne

**Ingredients** 2 tbsp olive oil, 500 g minced beef, 500 ml tomato sauce, 100 ml beef stock, 150 g dried lasagne sheets, 1 onion (chopped), 200 g grated cheese, 1 tbsp each of dried parsley flakes, oregano, basil.

**Directions** Prepare tomato meat sauce. Heat the oil in a frying pan, then cook the minced beef and chopped onion for about 10 min until browned all over. Pour over the tomato sauce and beef stock, add the dried herbs. Bring up to the boil, then simmer for 30 min. Cook lasagne noodles according to package directions. Layer the lasagne noodle, meat sauce, and cheese then repeat. Then sprinkle evenly with remaining cheese on the top of layer of noodles and bake.

# Cooking Smart

## Apple pie

- Ingredients**
- **Pastry:** 275 g flour, 1/2 tbsp salt, 125 g white castor sugar, 8 g vanilla sugar, 175 g cold butter, 1 egg (beaten).
  - **Filling:** 750 g firm whole apples, 1 tbsp lemon juice, 40 g sugar, 1/2 tbsp cinnamon, 50 g seedless raisins, 2 tbsp bread crumbs.

**Directions** Sift the flour with the salt above a big bowl. Sift the castor sugar and vanilla sugar with it. Cut with 2 knives the butter through the flour in small cubes. Add 3/4 of the beaten egg. Knead all the ingredients in the food processor until a crumbly mass appears. Form the dough into a ball with your hands. Wrap it in plastic foil and leave it chilled for about 30 min.

Grease the spring tin (24-26 cm diameter) and dust the surface with flour. Roll out 3/4 of the dough till 5 mm thickness. Put it in the tin (bottom and sides).

Peel and core the apples. Cut them in cubes of about 3/4 x 3/4 cm. Sprinkle the apples with lemon juice and mix well. Wash and dry the currants and raisins. Add sugar, cinnamon, raisins and currants. Mix well and sprinkle the bottom of dough with bread crumbs. Press slightly.

Roll out the rest of the dough. Cut the dough in small strips and put them cross wise on the filling. Brush the pie evenly with the rest of the beaten egg.

## Quiche Lorraine

- Ingredients**
- **Pastry:** 200 g plain flour, 80 g butter, 1 egg.
  - **Filling:** 75 g cubed fatless bacon, 125 ml cream, 125 g crème fraiche, 2 eggs, beaten, 100 g grated cheese from Switzerland, salt and pepper.

**Directions** To make the pastry, put the flour, butter and egg in a bowl and mix to a soften pastry and then rest it in the refrigerator for 30 min. Roll out the pastry and placed in the greased ceramic dish for quiche (25 cm diameter). Prick the bottom with a fork. Mix the egg, cream, crème fraiche, cheese, salt and pepper. Pour it on the pastry just before baking.

## Fruit crumbles

- Ingredients**
- **Topping:** 200 g flour, 100 g butter, 100 g sugar, 2 g salt, 2 g cinnamon powder.
  - **Fruit:** 600 g mixed fruits.

**Directions** Mix all ingredients until to be crumble for making topping. Spread the mixed fruits into an oven dish and sprinkle the crumble.

---

### Homemade pizza

- Ingredients**
- **Pizza dough:** 300 g flour, 7 g dried yeast, 1 tbsp olive oil, 200 ml warm water, 1 tbsp sugar and salt.
  - **Topping:** 400 g sliced vegetable (aubergine, courgette, onion, tomato), 100 g Ham or bacon (chopped), 100 g grated cheese.

**Directions** Put the flour, yeast, oil, salt, sugar and warm water in a bowl and mix to a wettish dough. Knead in a mixer or by hand about 5-10 min. Cover with lid and place in oven for 30 min at 35 °C to prove. Roll out the dough on a floured surface into a rectangle shape and put on the tray or pizza pan. Spread the tomato puree on the dough and place ham, mushroom, olive and tomato. Sprinkle evenly with cheese on the top and bake.

### Roast sirloin of beef

- Ingredients** 1 kg sirloin of beef joint, 5 g salt, 1 g pepper, 3 g each of rosemary, thyme.

**Directions** Season the beef with salt, pepper and rosemary and leave in refrigerator for 1 hour. Put on the Wire rack. Put it in the oven and cook.

---

### Herb roasted lamb chops

- Ingredients** 1 kg lamb chops (6 pieces), 4 large garlic cloves (pressed), 1 tbsp fresh thyme (crushed), 1 tbsp fresh rosemary (crushed), 2 tbsp salt, 2 tbsp olive oil.

**Directions** Mix the salt, garlic, herbs and oil and add the lamb. Turn to coat and leave at a room temperature at least 30 min to 1 hour.

### Rack of pork ribs

- Ingredients** 2 racks pork spare ribs, 1 tbsp black peppercorns, 3 bay leaves, 1 onion (chopped), 3 garlic cloves (chopped), 85 g brown sugar, 3 tbsp Worcestershire sauce, 2 tbsp Tomato puree, 2 tbsp olive oil.

**Directions** Make a barbecue sauce. Heat oil in a sauce pan and add the onion. Cook until softened and add remaining ingredients. Broil and reduce heat and simmer for 30 min until thickened. Marinate the rib with the barbecue sauce at least 30 min to 1 hour.

# Maintenance

## Cleaning

### ⚠ WARNING

- Make sure the oven and accessories are cool before cleaning.
- Do not use abrasive cleaning agents, hard brushes, scouring pads or cloths, steel wool, knives or any other abrasive materials.

### Oven interior

- For cleaning the interior of the oven, use a clean cloth and a mild cleaning agent or warm soapy water.
- Do not hand-clean the door seal.
- To avoid damaging the enamelled oven surfaces, only use standard oven cleaners.
- To remove stubborn soils, use a special oven cleaner.

### Oven exterior

If there are fingerprints, grease, or stains on the exterior (such as the door surface, handle, or display), clean with a soft cloth with a glass cleaner or neutral detergent, and then wipe dry with a soft, clean, dry cloth.

Grease and dirt can remain, especially around the handle because of the hot air coming from inside. It is recommended to clean the handle after each use.

### Accessories

Wash the accessories after every use, and dry it with a tea towel. To remove stubborn impurities, soak the used accessories in warm soapy water for about 30 minutes before washing.

### Catalytic enamel surface (applicable models only)

The removable parts are coated with dark grey catalytic enamel. They can be soiled with oil and fat spattered by the circulating air during convection heating. However, these impurities burn off at oven temperatures of 200 °C or above.

1. Remove all accessories from the oven.
2. Clean the interior of the oven.
3. Select **Convection** mode with max temperature, and run the cycle for an hour.

### Door

Do not remove the oven door unless for cleaning purposes. To remove the door for cleaning, follow these instructions.

### ⚠ WARNING

The oven door is heavy.

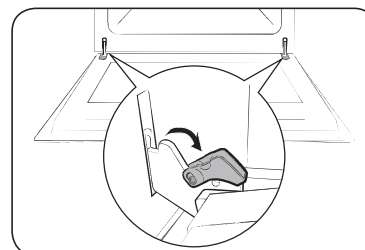

1. Open the door and flip open the clips at both hinges.

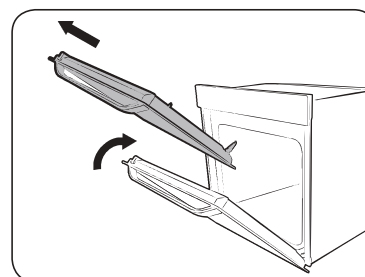

2. Close the door approximately 70°. Hold the oven door by the sides using both hands, and lift and pull upwards until the hinges are removed.
3. Clean the door with soapy water and a clean cloth.

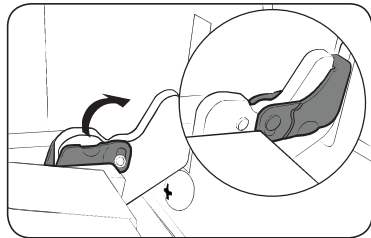

4. When done, follow steps 1 to 2 in the reverse order to reinstall the door. Make sure the clips are hinged on both sides.

### Door glass

Depending on the model, the oven door is equipped with 3-4 sheets of glass placed against each other. Do not remove the door glass unless for cleaning purposes. To remove the door glass for cleaning, follow these instructions.

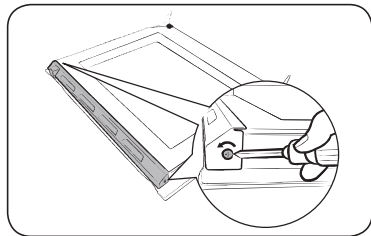

1. Use a screwdriver to remove the screws on the left and right sides.

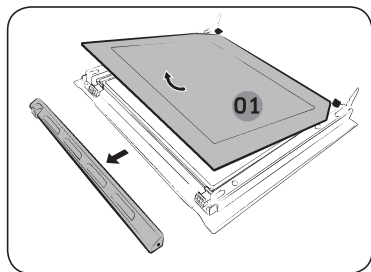

2. Detach the coverings in the arrow directions.
3. Remove the first sheet from the door.

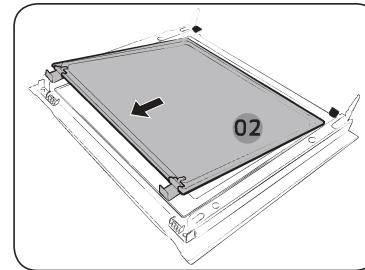

4. Remove the second sheet from the door in the arrow direction.

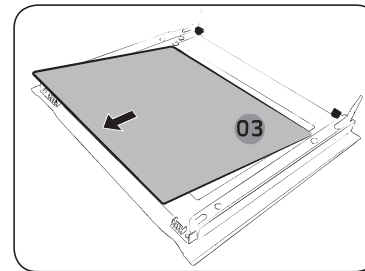

5. Remove the third sheet from the door in the arrow direction.
6. Clean the glass with soapy water and a clean cloth.

### ⚠ CAUTION

To identify the correct side of the sheet, locate the "PYRO" mark on the corner of every sheet.

Correct direction: PYRO-\*\*-\*\*

Wrong direction: \*\*--\*\*-ORYP

# Maintenance

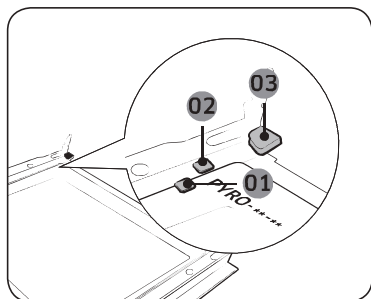

- 01 Support clip 1
- 02 Support clip 2
- 03 Support clip 3

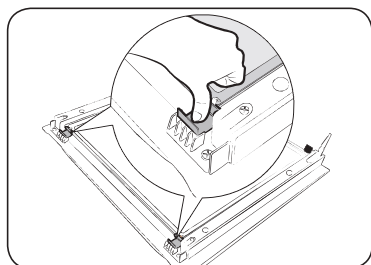

7. When done, reinsert the sheets as follows:
  - See the picture and locate the hinges. Insert sheet 3 below support clip 1, sheet 2 between support clip 1 and 2, and sheet 1 into support clip 3 in this order. Make sure the printed side of sheets is inserted inward.
8. After insert the sheet 2, press down the glass clips and check if they secure the glass sheet properly.
9. Follow steps 1-2 above in the reverse order to reinstall the coverings.

### **⚠ WARNING**

To prevent heat leaks, make sure you properly reinsert the glass sheets.

### Ceiling (applicable models only)

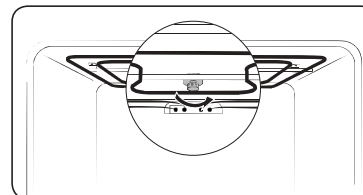

1. Put down the grill heater. For this, turn the circular nut anticlockwise while holding the grill heater. The grill heater is not a removable part. Do not force the grill heater down.

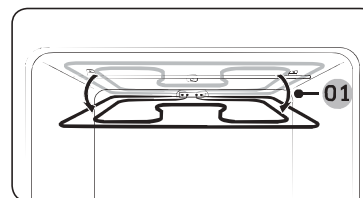

2. Clean the ceiling of the oven with soapy water and a clean cloth.

01 Approx. 12°

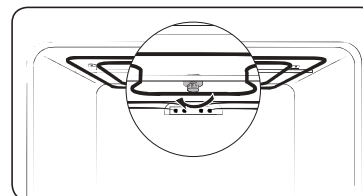

3. When done, put the grill heater back and turn the circular nut clockwise.

### Side racks (applicable models only)

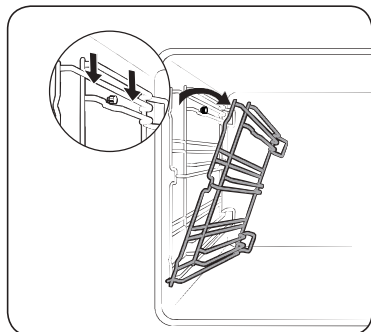

1. Press the top line of the left side rack, and lower by approximately 45°.

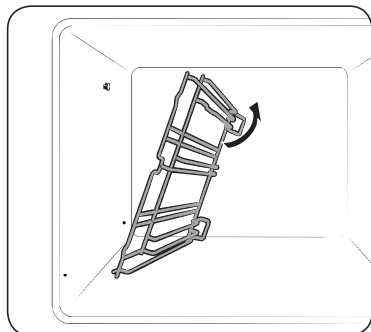

2. Pull and remove the bottom line of the left side rack.
3. Remove the right side rack in the same way.
4. Clean both side racks.
5. When done, follow steps 1 to 2 in the reverse order to reinsert the side racks.

#### NOTE

The oven operates without the side racks and racks in position.

## Replacement

### Bulbs

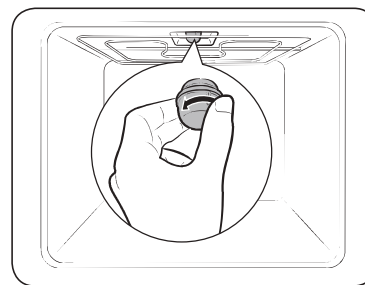

1. Remove the glass cap by turning anti-clockwise.
2. Replace the oven light.
3. Clean the glass cap.
4. When done, follow step 1 in the reverse order to reinsert the glass cap.

#### WARNING

- Before replacing a bulb, turn off the oven and unplug the power cord.
- Use only 25-40 W / 220-240 V, 300 °C heat-resistant bulbs. You can purchase approved bulbs at a local Samsung service center.
- Always use a dry cloth when handling a halogen bulb. This is to prevent the bulb from being tampered with fingerprints or sweat, resulting in a shortened lifecycle.

### Side oven light

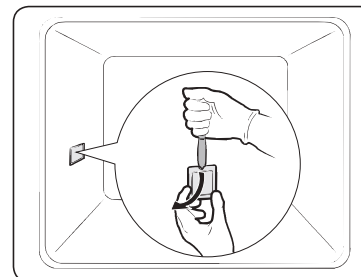

1. Hold the lower end of the cover of the side oven light with one hand, and use a flat-sharp tool such as a table knife to remove the cover as shown.
2. Replace the side oven light.
3. Reinsert the light cover.

# Troubleshooting

## Checkpoints

If you encounter a problem with the oven, first check the table below and try the suggestions. If the problem continues, contact a local Samsung service centre.

Problem	Cause	Action
The buttons cannot be pressed properly.	<ul style="list-style-type: none"> <li>If there is foreign matter caught between the buttons</li> <li>Touch model: if there is moisture on the exterior</li> <li>If the Lock function is set</li> </ul>	<ul style="list-style-type: none"> <li>Remove the foreign matter and try again.</li> <li>Remove the moisture and try again.</li> <li>Check whether the Lock function is set.</li> </ul>
The time is not displayed.	<ul style="list-style-type: none"> <li>If there is no power supplied</li> </ul>	<ul style="list-style-type: none"> <li>Check whether there is power supplied.</li> </ul>
The oven does not work.	<ul style="list-style-type: none"> <li>If there is no power supplied</li> </ul>	<ul style="list-style-type: none"> <li>Check whether there is power supplied.</li> <li>Check if the Demo mode is on.</li> </ul>
The oven stops while in operation.	<ul style="list-style-type: none"> <li>If it is unplugged from the power socket</li> </ul>	<ul style="list-style-type: none"> <li>Reconnect the power.</li> </ul>

Problem	Cause	Action
The power turns off during operation.	<ul style="list-style-type: none"> <li>If continuous cooking takes a long time</li> <li>If the cooling fan does not work</li> <li>If the oven is installed in a place without good ventilation</li> <li>When using several power plugs in the same socket</li> </ul>	<ul style="list-style-type: none"> <li>After cooking for a long time, let the oven cool.</li> <li>Listen for the sound of the cooling fan.</li> <li>Keep the gaps specified in the product installation guide.</li> <li>Use a single plug.</li> </ul>
There is no power to the oven.	<ul style="list-style-type: none"> <li>If there is no power supplied</li> </ul>	<ul style="list-style-type: none"> <li>Check whether there is power supplied.</li> </ul>
The oven exterior is too hot during operation.	<ul style="list-style-type: none"> <li>If the oven is installed in a place without good ventilation</li> </ul>	<ul style="list-style-type: none"> <li>Keep the gaps specified in the product installation guide.</li> </ul>
The door cannot be opened properly.	<ul style="list-style-type: none"> <li>If there is food residue stuck between the door and product interior</li> </ul>	<ul style="list-style-type: none"> <li>Clean the oven well and then open the door again.</li> </ul>
The interior light is dim or does not turn on.	<ul style="list-style-type: none"> <li>If the lamp turns on and then off</li> <li>If the lamp is covered by foreign matter during cooking</li> </ul>	<ul style="list-style-type: none"> <li>The lamp automatically turns off after a certain amount of time to save power. You can turn it on again by pressing <b>Oven light</b>.</li> <li>Clean the inside of the oven and then check.</li> </ul>

Problem	Cause	Action
There is electricity coming from the machine.	<ul style="list-style-type: none"> <li>If the power supply is not properly grounded</li> <li>If you are using a socket without grounding</li> </ul>	<ul style="list-style-type: none"> <li>Check whether the power supply is properly grounded.</li> </ul>
There is water dripping.	<ul style="list-style-type: none"> <li>There may be water or steam in some cases depending on the food. This is not a product malfunction.</li> </ul>	<ul style="list-style-type: none"> <li>Let the oven cool and then wipe with a dry dish towel.</li> </ul>
There is steam through a crack in the door.		
There is water remaining in the oven.		
The brightness inside the oven varies.	<ul style="list-style-type: none"> <li>The brightness changes depending on power output changes.</li> </ul>	<ul style="list-style-type: none"> <li>Power output changes during cooking are not malfunctions, so there is no need to worry.</li> </ul>
Cooking is finished, but the cooling fan is still running.	<ul style="list-style-type: none"> <li>The fan automatically runs for a certain amount of time to ventilate inside the oven.</li> </ul>	<ul style="list-style-type: none"> <li>This is not a product malfunction, so there is no need to worry.</li> </ul>

Problem	Cause	Action
The oven does not heat.	<ul style="list-style-type: none"> <li>If the door is open</li> <li>If oven controls are not correctly set</li> <li>If the household fuse has been blown or the circuit breaker has operated</li> </ul>	<ul style="list-style-type: none"> <li>Close the door and restart.</li> <li>Refer to the chapter on oven operation and reset the oven.</li> <li>Replace the fuse or reset the circuit. If it happens repeatedly, call an electrician.</li> <li>Check if the Demo mode is on.</li> </ul>
Smoke comes out during operation.	<ul style="list-style-type: none"> <li>During initial operation</li> <li>If there is food on the heater</li> </ul>	<ul style="list-style-type: none"> <li>Smoke may come from the heater when you first use the oven. This is not a malfunction, and if you run the oven 2-3 times, it should stop happening.</li> <li>Let the oven cool sufficiently and remove the food from the heater.</li> </ul>
There is a burning or plastic smell when using the oven.	<ul style="list-style-type: none"> <li>If using plastic or other containers that are not heat-resistant</li> </ul>	<ul style="list-style-type: none"> <li>Use glass containers suitable for hot temperatures.</li> </ul>

# Troubleshooting

Problem	Cause	Action
The oven does not cook properly.	<ul style="list-style-type: none"> <li>If the door is often opened during cooking</li> </ul>	<ul style="list-style-type: none"> <li>Do not frequently open the door unless you are cooking things that need to be turned. If you frequently open the door, the interior temperature will be lower and this may affect the results of your cooking.</li> </ul>
I can hear water boiling during steam cooking.	<ul style="list-style-type: none"> <li>This is because water is heated using the steam heater</li> </ul>	<ul style="list-style-type: none"> <li>This is not a product malfunction, so there is no need to worry.</li> </ul>
Steam cooking does not work.	<ul style="list-style-type: none"> <li>If there is no water in the water supply tank</li> </ul>	<ul style="list-style-type: none"> <li>Add water to the tank and try again.</li> </ul>
The set is warm during pyro cleaning	<ul style="list-style-type: none"> <li>This is because pyro cleaning uses high temperatures</li> </ul>	<ul style="list-style-type: none"> <li>This is not a product malfunction, so there is no need to worry.</li> </ul>
There is a burning smell during pyro cleaning.	<ul style="list-style-type: none"> <li>Pyro cleaning uses high temperatures, so you may smell food residue burning.</li> </ul>	<ul style="list-style-type: none"> <li>This is not a product malfunction, so there is no need to worry.</li> </ul>
Steam cleaning does not work.	<ul style="list-style-type: none"> <li>This is because the temperature is too high</li> </ul>	<ul style="list-style-type: none"> <li>Let the oven cool and then use.</li> </ul>

## Information codes

If the oven fails to operate, you may see an information code on the display. Check the table below and try the suggestions.

Code	Meaning	Action
C-d1	Door lock malfunctions	Turn off the oven and then restart. If the problem continues, turn off all power for 30 seconds or more and then reconnect. If the problem is not fixed, please contact a service centre.
C-20	Sensor malfunctions	
C-21		
C-22		
C-23		
C-F1		
C-70	Steam-related problems	
C-72		
C-F0	If there is no communication between the main PCB and sub PCB	
C-F2	Occurs when a communication problem is maintained between the Touch IC <-> Main or Sub micom	
C-d0	<b>Button problem</b> Occurs when a button is pressed and held for a period of time.	Clean the buttons and make sure there is no water on/around them. Turn off the oven and try again. If the problem continues, contact a local Samsung service centre.

Code	Meaning	Action
-dC-	If the divider is removed during cooking in Dual cook mode. If the divider is inserted during cooking in Single cook mode.	The divider must not be removed during cooking in Dual cook mode. Turn off the oven and then restart. If the problem continues, turn off all power for 30 seconds or more and then reconnect. If the problem is not fixed, please contact a service centre.
S-01	<b>Safety shutoff</b> Oven has continued operating at a set temperature for an extended time. <ul style="list-style-type: none"> <li>Under 105 °C - 16 hours</li> <li>From 105 °C to 240 °C - 8 hours</li> <li>From 245 °C to Max - 4 hours</li> </ul>	This is not a system failure. Turn off the oven and remove food. Then, try again normally.

## Technical specifications

SAMSUNG strives to improve its products at all times. Both the design specifications and these user instructions are thus subject to change without notice.

Connection voltage		230-240 V ~ 50 Hz
Maximum connected load power		3650-3950 W
Dimensions (W x H x D)	Main unit	595 x 596 x 570 mm
	Built-in	560 x 579 x 549 mm
Volume		75 liter
Weight	Net (with all accessories)	
	NV75T8979** : 50.3 kg NV75T8879** : 47.4 kg	

# Appendix

## Product data sheet

SAMSUNG		SAMSUNG
Model identification		NV75T8979** / NV75T8879**
Energy Efficiency Index per cavity (EEI <sub>cavity</sub> )		81.6
Energy Efficiency Class per cavity		A+
Energy consumption (electricity) required to heat a standardised load in a cavity of an electric heated oven during a cycle in conventional mode per cavity (electric final energy) (EC <sub>electric cavity</sub> )		1.05 kWh/cycle
Energy consumption required to heat a standardised load in a cavity of an electric heated oven during a cycle in fan-forced mode per cavity (electric final energy) (EC <sub>electric cavity</sub> )		0.71 kWh/cycle
Number of cavities		1
Heat source per cavity (electricity or gas)		electricity
Volume per cavity (V)		75 L
Type of oven		Built-in
Mass of the appliance (M)		45.7 kg
WiFi	Standby-mode Power Consumption (W)	1.9 W
	Period of time for the power management (min)	20 min.
Off mode	Power consumption	0.5 W
	Period of time for the power management (min)	10 min.

Data determined according to standard EN 60350-1, EN 50564, Commission Regulations (EU) No 65/2014 and (EU) No 66/2014, and Regulation (EC) No 1275/2008.

## Energy saving tips

- During cooking, the oven door should remain closed except for turning food over. Do not open the door frequently during cooking to maintain the oven temperature and to save energy.
- Plan oven use to avoid turning the oven off between cooking one item and the next to save energy and reduce the time for re-heating the oven.
- If cooking time is more than 30 minutes, the oven may be switched off 5-10 minutes before the end of the cooking time to save energy. The residual heat will complete the cooking process.
- Wherever possible cook more than one item at a time.

# Memo

## Open Source Announcement

The software included in this product contains open source software. You may obtain the complete corresponding source code for a period of three years after the last shipment of this product by sending an email to <mailto:oss.request@samsung.com>.

It is also possible to obtain the complete corresponding source code in a physical medium such as a CD-ROM; a minimal charge will be required.

The following URL [http://opensource.samsung.com/opensource/OVEN\\_R18\\_TZ4/seq/0](http://opensource.samsung.com/opensource/OVEN_R18_TZ4/seq/0) leads to the download page of the source code made available and open source license information as related to this product. This offer is valid to anyone in receipt of this information.



## QUESTIONS OR COMMENTS?

COUNTRY	CALL	OR VISIT US ONLINE AT
AUSTRIA	0800 72 67 864 (0800-SAMSUNG)	<a href="http://www.samsung.com/at/support">www.samsung.com/at/support</a>
BELGIUM	02-201-24-18	<a href="http://www.samsung.com/be/support">www.samsung.com/be/support</a> (Dutch) <a href="http://www.samsung.com/be_fr/support">www.samsung.com/be_fr/support</a> (French)
DENMARK	707 019 70	<a href="http://www.samsung.com/dk/support">www.samsung.com/dk/support</a>
FINLAND	030-6227 515	<a href="http://www.samsung.com/fi/support">www.samsung.com/fi/support</a>
FRANCE	01 48 63 00 00	<a href="http://www.samsung.com/fr/support">www.samsung.com/fr/support</a>
GERMANY	06196 77 555 77	<a href="http://www.samsung.com/de/support">www.samsung.com/de/support</a>
ITALIA	800-SAMSUNG (800.7267864)	<a href="http://www.samsung.com/it/support">www.samsung.com/it/support</a>
CYPRUS	8009 4000 only from landline, toll free	<a href="http://www.samsung.com/gr/support">www.samsung.com/gr/support</a>
GREECE	80111-SAMSUNG (80111 726 7864) only from land line (+30) 210 6897691 from mobile and land line	<a href="http://www.samsung.com/gr/support">www.samsung.com/gr/support</a>
LUXEMBURG	261 03 710	<a href="http://www.samsung.com/be_fr/support">www.samsung.com/be_fr/support</a>
NETHERLANDS	088 90 90 100	<a href="http://www.samsung.com/nl/support">www.samsung.com/nl/support</a>
NORWAY	21629099	<a href="http://www.samsung.com/no/support">www.samsung.com/no/support</a>
PORTUGAL	808 207 267	<a href="http://www.samsung.com/pt/support">www.samsung.com/pt/support</a>
SPAIN	91 175 00 15	<a href="http://www.samsung.com/es/support">www.samsung.com/es/support</a>
SWEDEN	0771 726 786	<a href="http://www.samsung.com/se/support">www.samsung.com/se/support</a>
SWITZERLAND	0800 726 786 (0800-SAMSUNG)	<a href="http://www.samsung.com/ch/support">www.samsung.com/ch/support</a> (German) <a href="http://www.samsung.com/ch_fr/support">www.samsung.com/ch_fr/support</a> (French)
UK	0330 SAMSUNG (7267864)	<a href="http://www.samsung.com/uk/support">www.samsung.com/uk/support</a>
IRELAND (EIRE)	0818 717100	<a href="http://www.samsung.com/ie/support">www.samsung.com/ie/support</a>



DG68-01258D-00