



Montage- und Serviceanleitung
 Instructions de montage et d'entretien
 Istruzioni di montaggio e di assistenza
 Instrucciones de montaje y servicio
 Installation and service instructions

802158

Küchenmischer
 Mitigeur de cuisine
 Miscelatore da cucina
 Mezclador de cocina
 Kitchen faucet

**KWC INOX
 KWC SUPRIMO**

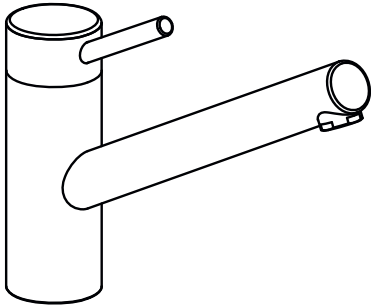

10.271.023.700
 10.271.023.700FL

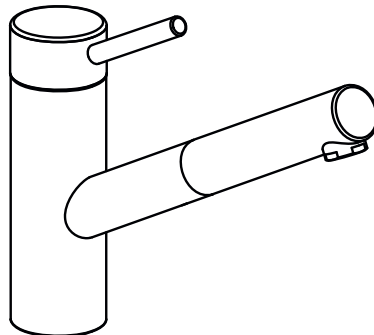

10.271.103.700
 10.271.103.700FL

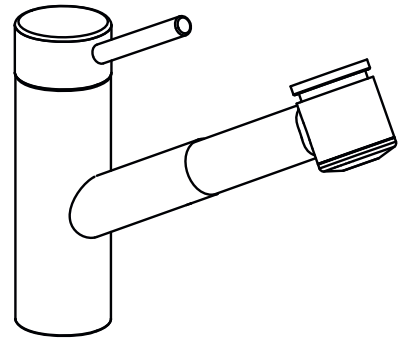

10.271.033.700
 10.271.033.700FL
 10.271.033.736
 10.271.033.736FL

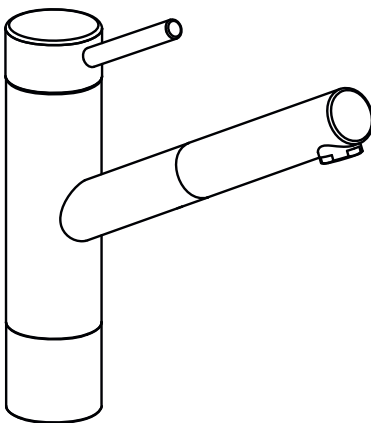

10.271.303.700
 10.271.303.700FL

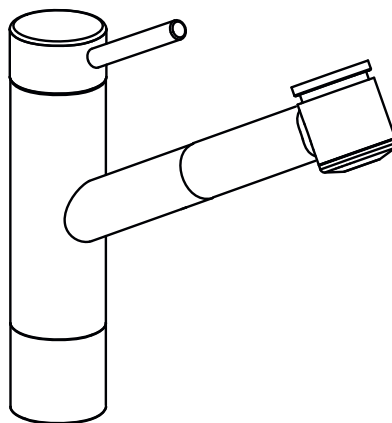

10.271.333.700
 (USA only)

Betriebsdaten

Caractéristiques de fonctionnement

Caratteristiche di funzionamento

Datos de servicio

Operating data

Idealer Betriebsdruck	: 3 bar
Max. Betriebsdruck	: 5 bar
Min. Betriebsdruck	: 1 bar
Druckgleichheit empfehlenswert.	
Ideale Wassertemperatur	: 60 °C
Max. Wassertemperatur	: 80 °C



Achtung:
Vor Montage die Leitungen gründlich durchspülen!

Weitere Informationen finden Sie in unseren detaillierten Verkaufsunterlagen.

Pressione di servizio ideale	: 3 bar
Pressione di servizio mass.	: 5 bar
Pressione di servizio min.	: 1 bar
Si raccomanda pressioni uguali.	
Temperatura acqua calda ideale	: 60°C
Temperatura acqua calda mass.	: 80°C



Attenzione:
Risciacquare bene le tubazioni prima del montaggio!

Ulteriori informazioni le troverete nelle nostre dettagliate documentazioni.

Pression de service idéale	: 3 bar
Pression de service max.	: 5 bar
Pression de service min.	: 1 bar
Egalité de pression recommandée.	
Température idéale de l'eau	: 60°C
Température max. de l'eau	: 80°C



Attention:
Rincer à fond la tuyauterie avant le montage!

Pour informations supplémentaires voir nos documentations de vente détaillées.

Presión ideal de servicio	: 3 bar
Presión máxima de servicio	: 5 bar
Presión mínima de servicio	: 1 bar
Se recomienda la igualdad de las presiones.	
Temperatura ideal del agua	: 60 °C
Temperatura máxima del agua	: 80 °C



Atención:
Enjuagar escrupulosamente las tuberías antes del montaje!

Información más detallada en nuestra documentación de ventas.

Ideal operating pressure	: 3 bar / 45 PSI / 300 kPa
Max. operating pressure	: 5 bar / 70 PSI / 500 kPa
Min. operating pressure	: 1 bar / 14.5 PSI / 100 kPa
Equal pressures are recommended.	
Ideal water temperature	: 60 °C (140°F)
Max. water temperature	: 80 °C (180°F)



Attention:
Flush pipes thoroughly before installation!

For further information refer to our detailed sales literature.

Driftstryck	: 3 bar / 300 kPa
Max. tryck	: 5 bar / 500 kPa
Min. tryck	: 1 bar / 100 kPa
Lika tryck på kall- och varmvatten rekommenderas.	
Driftstemperatur	: 60°C
Max temperatur	: 80°C



O.B.S.
Spola rören ordentligt innan blandare installeras!

För ytterligare information se produktblad.



- D Schäden, die infolge unsachgemässer Behandlung, natürlicher Abnutzung oder zu grosser Inanspruchnahme entstanden sind, sind von unseren Garantieleistungen ausgeschlossen!
- F Ces dommages survenus en raison d'un traitement inadéquat, des signes d'usure traitement inadéquat, naturels ou du grand utilisation, sont exclus de notre garantie.
- I Danni ai rubinetti, conseguenti da un trattamento non appropriato, sono esclusi dalla nostra garanzia!
- Sp Daños, debidos a un tratamiento inadecuado, son excluidos de la nuestra garantía.
- E Damages on the faucet resulting from incorrect handling are excluded from the manufacturers warranty!
- S För att Garantien skall gälla skall blandaren vara monterad och använd på ett korrekt sätt.

EU/AUS

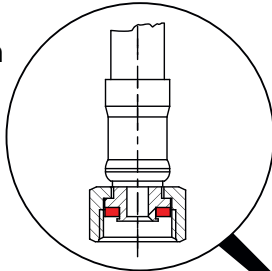

USA/CAN

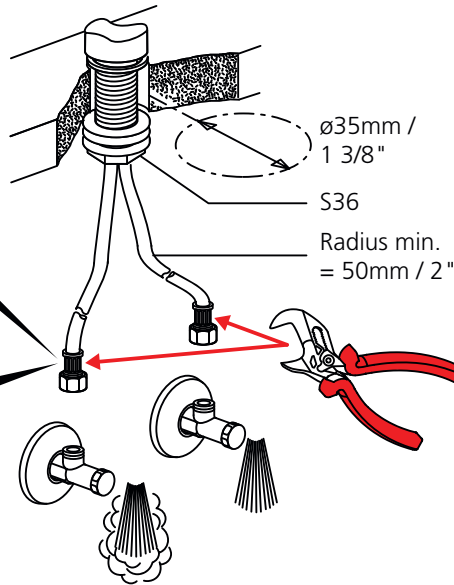
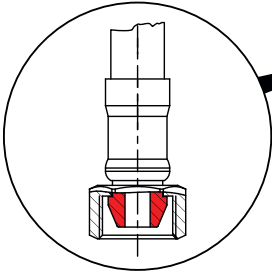

Beim Anschliessen zwingend
gemäss Abbildung
oberhalb der Mutter gehalten!

Pour le raccordement, il est impératif
d'appliquer une force contraire au-dessus
de l'écrou (voir illustration)!

Eeguire il collegamento sopra il
dato secondo la figura.

Al conectar, sujetar por encima de la
tuerca siguiendo exactamente el dibujo

Hold above the nut during installation
as shown in the illustration.

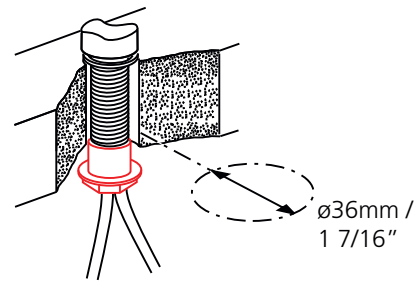
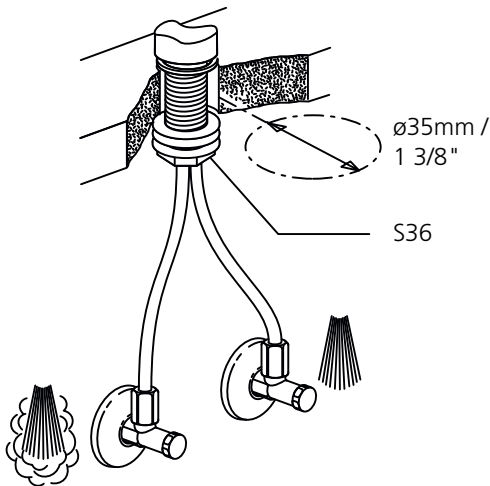

Verlängerungsmutter L= 40mm
Ecrou allongé L= 40mm
Dado prolongato L= 40mm
Tuerca de prolongación L= 40mm
Extension nut L= 40mm / 1 1/2"

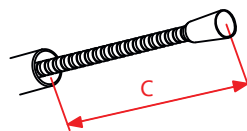

c = 700 mm, 27 9/16"

d = 500 mm, 19 11/16"

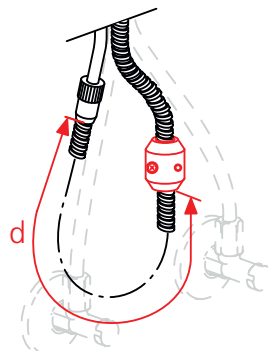

1

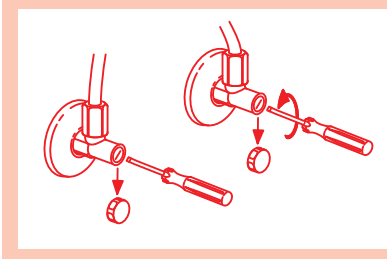

Kalt- und Warmwasser öffnen.
Ouvrir eau froide et chaude.
Aprire acqua fredda e calda.
Abrir la salida de agua fría y caliente.
Open cold and hot water.

2

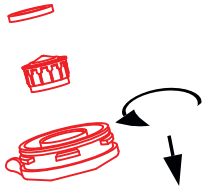

3

||||| D spülen
||||| F rincer
||||| I sciacquate
||||| Sp enjuagar
||||| E flush

4

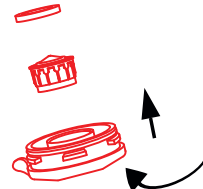

2



3

||||| D spülen
||||| F rincer
||||| I sciacquate
||||| Sp enjuagar
||||| E flush

4



Höchsttemperaturbegrenzung
 Limitation de la température max.
 Limitazione della temperatura massima
 Limitación de la temperatura máxima
 Maximum temperature limitation

Temperaturring
 Anneau de limitation
 Anello di limitazione
 Anillo de la temperatura
 Temperature ring

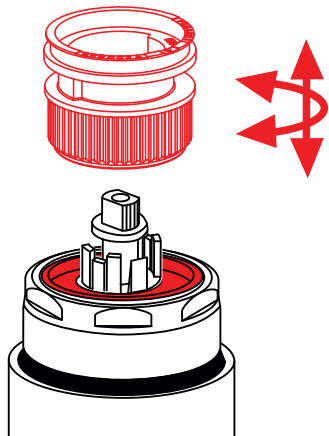

Max. Temperaturbereich :
 Plage de température max. :
 Campo di temperatura mass. :
 Gama de temperaturas máx. :
 Max. temperature range :

Begrenzter Temperaturbereich :
 Plage de température réduite :
 Campo di temperatura ridotto :
 Gama de temperaturas reducidas :
 Reduced temperature range :

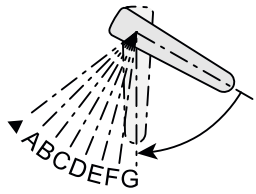
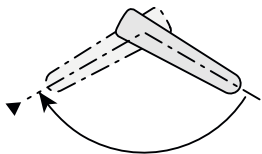
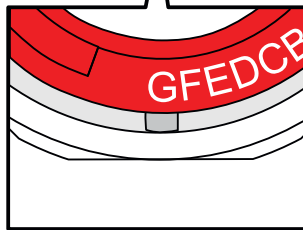
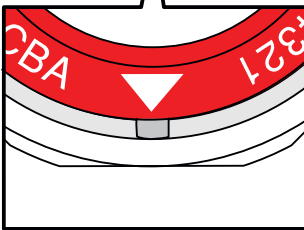
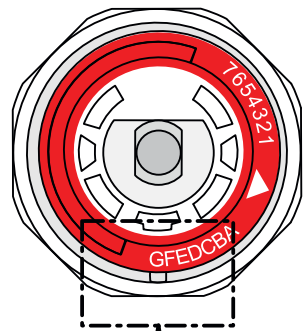
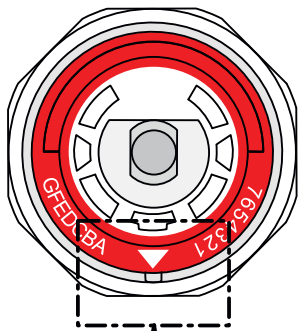

Pfeil auf Kerbe.
 Flèche sur encoche.
 Freccia su scanalatura.
 Flecha en la hendidura.
 Arrow on groove.

Position A - G
 Position A - G
 Position A - G
 Posición A - G
 Positions A - G

Mengenbegrenzung
 Limitation du débit
 Limitazione della portata
 Limitación del caudal
 Flow rate limitation

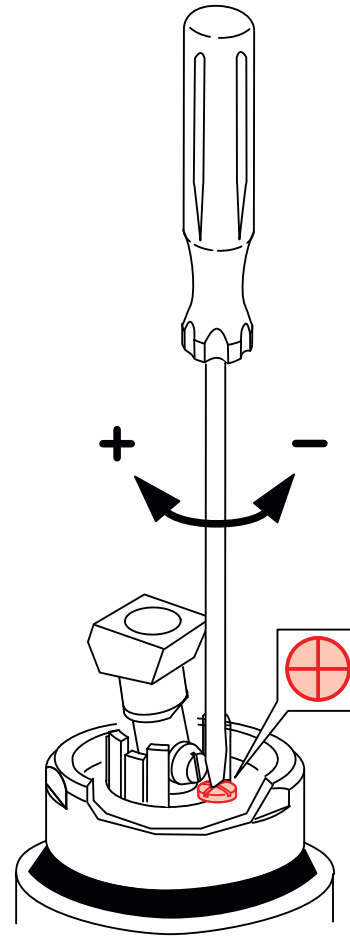

Ersatzteile
 Pièces de rechange
 Pezzi di ricambio
 Repuestos
 Spare parts

Es dürfen ausschliesslich **original Ersatzteile** verwendet werden!
 Utiliser seulement des **pièces de rechange originaux!**
 Usare soltanto i **pezzi di ricambio originali!**
 ¡Utilizar solamente los **Requetos originales!**
 Only the **original Spare parts** may be used!

10.271.023.700

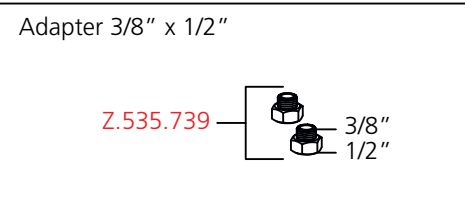
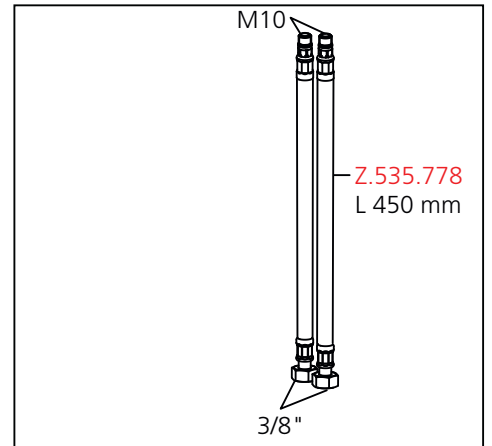
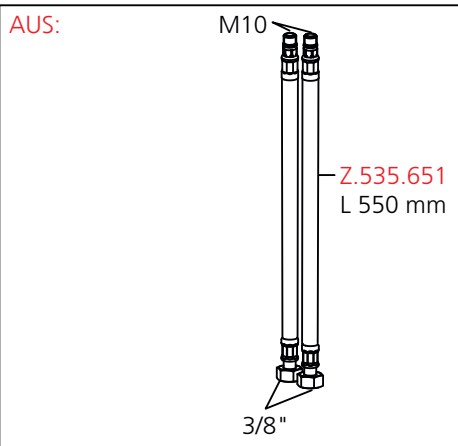
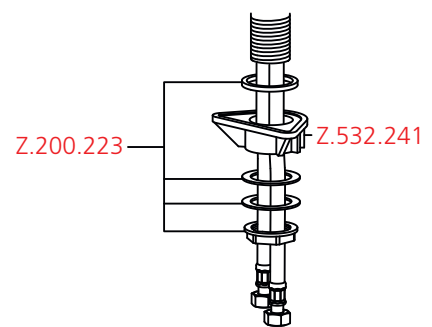
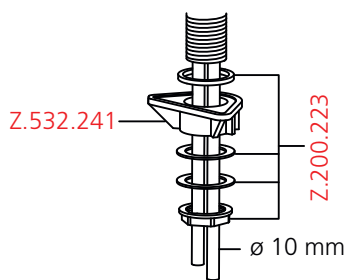
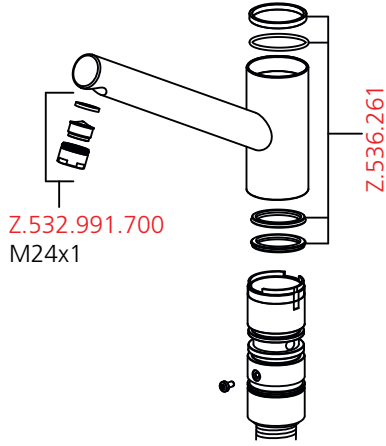
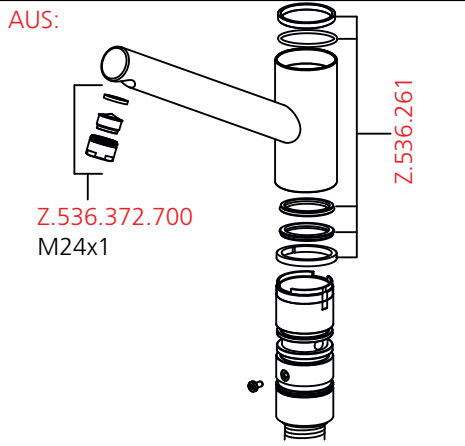
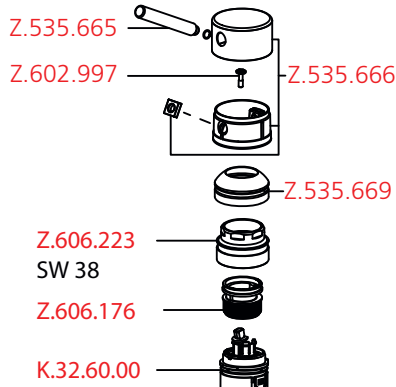

Ersatzteile
Pièces de rechange
Pezzi di ricambio
Repuestos
Spare parts

Es dürfen ausschliesslich **original Ersatzteile** verwendet werden!
Utiliser seulement des **pièces de rechange originaux!**
Usare soltanto i **pezzi di ricambio originali!**
¡Utilizar solamente los **Requetos originales!**
Only the **original Spare parts** may be used!

10.271.033.736

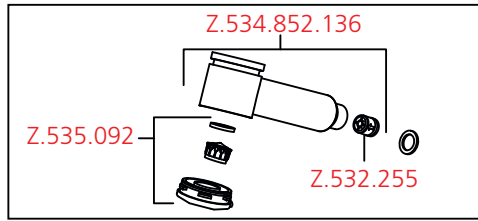

10.271.033.700
10.271.333.700

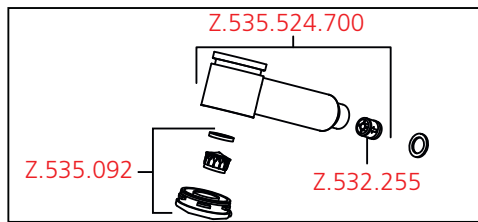

10.271.103.700
10.271.303.700

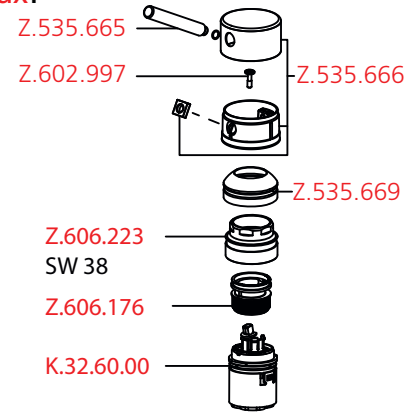
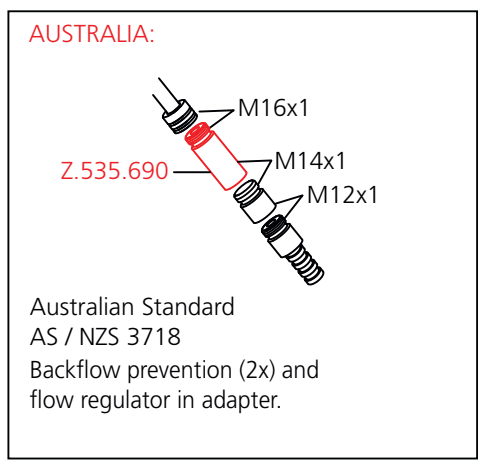
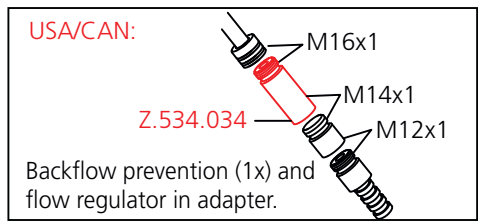
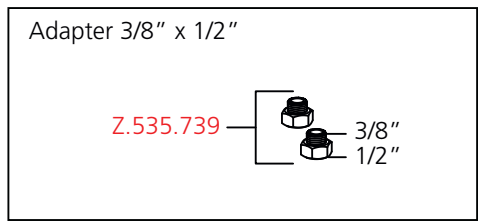
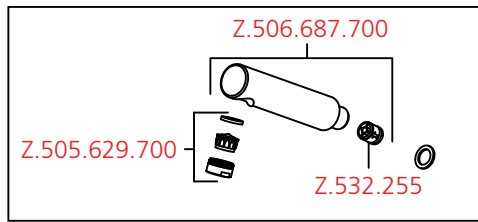

10.271.033.700
10.271.033.700
10.271.103.700

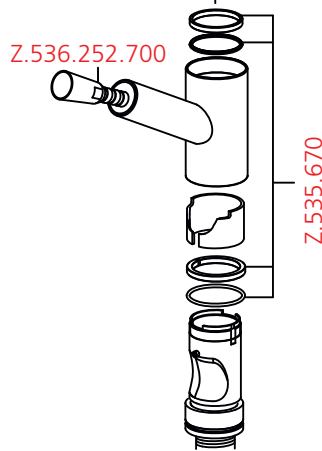

10.271.303.700
10.271.333.700 (USA only)

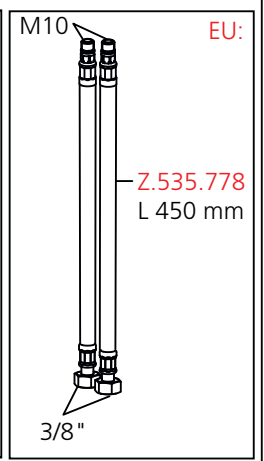
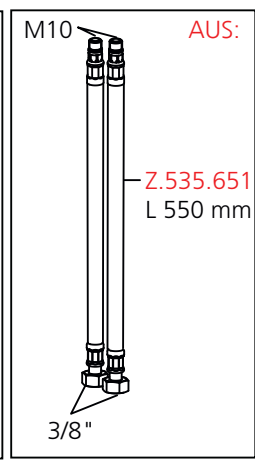
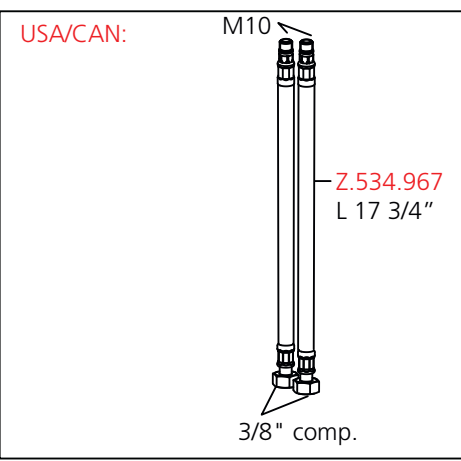
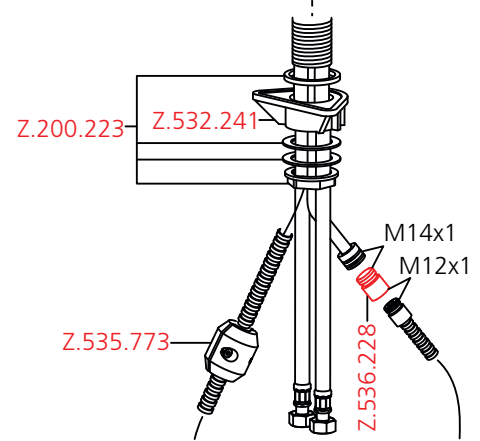
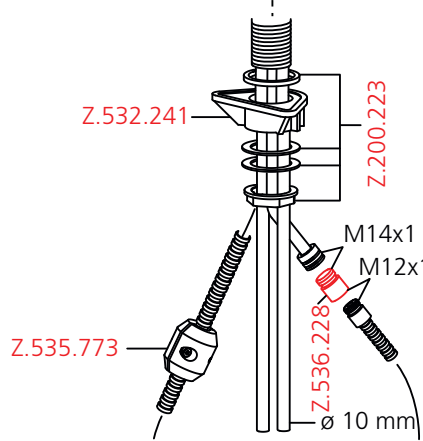
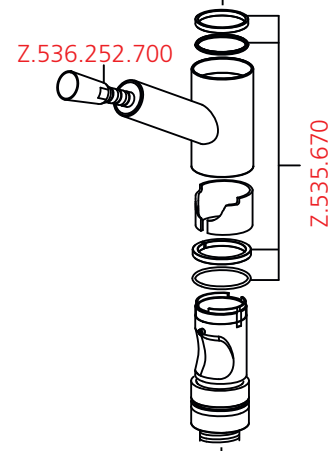

Pflegeanleitung für Armaturen und Zubehör
Instruction pour la maintenance des robinets et des accessoires
Istruzioni per la manutenzione di rubinetti e accessori
Instrucciones para el cuidado de griferías y accesorios
Maintenance / Cleaning instructions for faucets and accessories

Grundsätzliche Reinigungshinweise:

- Beim Reinigen muss die Oberfläche der Armatur kalt sein (Wärme beschleunigt die Zerstörung der Oberfläche)!
- Reinigungshinweise der Reinigungsmittelhersteller beachten!

Die Pflege:

- Armatur täglich mit weichem Lappen trocken reiben!
- Scheuernde Reinigungsmittel und Putzschwämme unbedingt vermeiden!

Die Reinigung:

- Schmutz- oder Kalkflecken auf der Armaturenoberfläche nur mit mildem Reinigungsmittel entfernen!
- Sofort nach dem Reinigen alle Reinigungsmittelrückstände mit kaltem Wasser wegspülen!
- Mit weichem Lappen trocken reiben.

Instructions principales pour le nettoyage:

- Durant le nettoyage, la surface du robinet doit être froide (la chaleur accélère l'usure de la surface)!
- Nous vous prions de faire attention aux indications mentionnées sur les nettoyages!
- Assurez vous que les produits ne contiennent pas d'acides ou des substances corrosives.

L'entretien:

- Le robinet doit être nettoyé chaque jour avec un chiffon mou.
- Evitez absolument l'usage des brillants pour métaux, éponges abrasives ou produits similaires!

Le nettoyage:

- Enlevez salissures et dépôts calcaires de la surface du robinet seulement avec des produits qui ne sont pas agressifs!
- Immédiatement après le nettoyage, rincer bien les résidus des détergents avec de l'eau froide!
- Sécher avec un chiffon mou.

Principali istruzioni per la pulizia:

- Durante la pulizia, la superficie del rubinetto deve essere fredda (il calore accelera il logorio della superficie)!
- Fare attenzione alle indicazioni riportate sui prodotti per la pulizia!
- Accertarsi che non contengano acidi o sostanze corrosive.

La manutenzione:

- Il rubinetto deve essere asciugato quotidianamente con un panno morbido.
- Evitare assolutamente paglietta, spugne abrasive o similari!

La pulizia:

- Togliere sporco e calcare dalla superficie del rubinetto solo con detersivi non aggressivi!
- Subito dopo la pulizia, sciacquare bene i residui di detersivo con acqua fredda!
- Asciugare con un panno morbido.

Avisos básicos de limpieza:

- Cuando se procede a limpiar la grifería, su superficie debe estar fría (el calor acelera la destrucción de la superficie)!
- Respetar los avisos de limpieza del fabricante del detergente!

Cuidado:

- Secar la grifería frotando diariamente con un paño blando!
- Evite, imprescindiblemente, detergentes y esponjas de limpieza raspantes!

Limpieza:

- Quitar las manchas de suciedad o cal en la superficie de la grifería sólo con un detergente poco agresivo!
- Inmediatamente después de la limpieza eliminar, enjuagando con agua fría, todos los residuos del detergente!
- Secar frotando con un paño blando.

General Cleaning Instructions:

- Faucet surface must be of room temperature before cleaning (elevated temperature increases damage of the surface).
- Cleaning instructions of the detergent manufacturer must be followed.

Maintenance:

- Rub the faucet daily dry with a soft cloth.
- Never use corrosive cleaners or cleaning pads.

Cleaning:

- Dirt or calcium deposits on the faucet surface must be removed with soft detergent or with soap water!
- Rinse well with water immediately after cleaning, until all detergent is removed from the surface.
- Dry with soft cloth.

Skötsel och underhåll:

- Blandaren skall vara rumstempererad innan rengöring (högre temperatur kan vara skadlig för ytbehandlingen).
- Instruktioner från rengöringsmedeltillverkaren skall följas.

Underhåll:

- Torka av blandaren dagligen med en mjuk trasa
- Använd aldrig kalklösande, sura- eller slipande skurmedel och svampar.

Rengöring:

- Smuts eller kalkavlagringar på blandarytan tas bort med mild rengöringsmedel eller mild tvållösning.
- Eftersköljning med rent vatten tills allt rengöringsmedel är borta.
- Torka med mjuk trasa.



- D Schäden, die infolge unsachgemässer Behandlung, natürlicher Abnutzung oder zu grosser Inanspruchnahme entstanden sind, sind von unseren Garantieleistungen ausgeschlossen!
- F Ces dommages survenus en raison d'un traitement inadéquat, des signes d'usure traitement inadéquat, naturels ou du grand utilisation, sont exclus de notre garantie.
- I Danni ai rubinetti, conseguenti da un trattamento non appropriato, sono esclusi dalla nostra garanzia!
- Sp Daños, debidos a un tratamiento inadecuado, son excluidos de la nuestra garantía.
- E Damages on the faucet resulting from incorrect handling are excluded from the manufacturers warranty!
- S För att Garantien skall gälla skall blandaren vara monterad och använd på ett korrekt sätt.



Recyclingpapier auf 100% Altpapierbasis.
 Papier de recyclage sur 100% bases de vieux papier.
 Riciclaggio della carta sulla base della carta straccia di 100%.
 Reciclaje del documento sobre base del papel usado del 100%.
 Recycling paper on 100% waste paper basis.
 Återvinning av papper 100%

Technische Änderungen vorbehalten
 Salvo cambiamenti tecnici
 Sous réserve de modifications techniques
 Derechos reservados para efectuar modificaciones técnicas
 Subject to technical alteration
 Med förbehåll för tekniska ändringar