

Samsung BO20 Dual Door Oven (Dual Cook Flex)

[> Web link](#)

Model
Samsung BO20 Dual Door Oven (Dual Cook Flex)

Energy efficiency class
A+

Manufacturer ID
NV75N7677RS/EU

Article no.
500.000.001.00

Appliance type
Ovens

Construction
Euro Norm 60 cm

VRG
10.00

Price CHF
880.- excl. VAT

Highlights

- 75 L cooking capacity - exceptionally spacious
- 50 automatic programs
- Dual Cook - cooking two different dishes at the same time
- Dual Door Flex™ - baking with more flexibility
- Practical: WiFi Smart Control, operating with smartphone and app
- Self-cleaning: pyrolysis and steam
- Cooking chamber with ceramic enamel: scratch-proof, anti-bacterial
- Easy to operate: retractable knob and sensor buttons

Product description

Construction: **Euro-Norm 60 cm**
GTIN-Nr.: **881643182809**

Efficiency and consumption

Energy efficiency class (from A+++ to D): **A+**
Energy efficiency index: **81,6**

Energy consumption

Energy consumption, conventional (kWh / cycle): **1,05 kWh**
Energy consumption, convection / hot air (kWh / cycle): **0,71 kWh**
Standby consumption: **0,9 W**
Consumption pyrolytic cleaning process (kWh / cycle): **5,0 kWh**

Design

Color control panel: **Black**
Material control panel: **Glass**
Frame / material: **Yes / stainless steel**

Display and operation

Display: **Digital display**
Display and lighting: **LED, ice blue**
Operation: **Retractable knob, sensor buttons, WiFi, Dual Door Flex™**

Interconnection of household appliances

Samsung Smart Home: **WiFi Smart Control**

Performance properties

max. adjustable temperature for top / bottom heat, convection / hot air: **275°C**
Temperature for steam operation:--
Microwave power output -
Useable grilling space: **1906 cm2**
Useable oven capacity: **75 L**

Dimensions

Height: **59.5 cm**
Width: **59 cm**
Depth: **54.9 cm**
Depth (from front of unit): **56.6 cm**
Depth with open door (in front of unit): **49.4 cm**
Unit dimensions (H x W x D) : **595 x 590 x 549 mm**

Empty weight

Unit weight: **47,2 kg**

Fittings

Inside dimensions (useable size) mm (height / width / depth): **375 x 465 x 397 mm**
Top and bottom heat: **Yes / Yes**
Convection:

Samsung BO20 Dual Door Oven (Dual Cook Flex)[> Web link](#)

-

Hot air: **Yes**

Steam:-

Microwave: -

Catalytic cleaning aid : -

Pyrolytic cleaning aid : **Yes**Grill heating element available / retrofittable: **Yes / -**Grill motor / convection grilling: **Yes**Timer switch / timer: **Yes**Drawer / warming drawer: - / **optional**Number of cooking chambers: **3**

Volume per cooking chamber

Single-chamber operation / top cooking chamber / bottom cooking chamber: **75 L / 34 L / 32 L**Number of shelf levels: **5**Lighting / inspection window: **Yes / Yes**Lighting : **2 x 40 W, halogen**Telescope rails: **Single**Cleaning: **Pyrolysis, steam cleaning**Cooling process: **Cooling ventilator**Interior lining: **Ceramic enamel****Operating modes**

Steam: -

Steam + heating: -

Steam + hot air: -

Steam + top heat + hot air:-

Steam + bottom heat + hot air: -

Top / bottom heat: **30~275°C**Hot air: **30~275°C**Hot air ECO: **30~275°C**Grill: large / eco / convection: **100~300°C / 100~300°C / -**Bottom heat + hot air: **40~275°C**Top heat + hot air: **40~275°C**Bottom heat : **100~230°C**

Fast cooking: -

Automatic roasting (ProRoasting) : **80~200°C**

Microwave + grill: -

Microwave + hot air: -

ProgramsSpecial functions: **Keeping food warm, pre-warming plates, fast pre-heating**Automatic programs: **50**Dual Cook: **Yes****Control functions**Control functions: **Time, kitchen timer, child safety, cooking timer, end time, delayed start, signal tone****Capacity**Total capacity: **3650-3950 W**Hot air : **1200 W**Top heat : **1600 / 1100 W**Bottom heat : **1100 W**Grill max. / min.: **1600 / 1100 W**Large-sized grill: **1600 W**

Steam:-

Microwave:-

Electrical connectionSupply voltage g: **230 V**Frequency : **50 Hz**Connection values: **3.65-3.95 kWh**Fuse protection: **16 A**Length power connection: - / **The connector cable must be provided by the customer**Power plug: - / **Direct connection****Technical data**Standard width: **Euro-Norm 60 cm**Standard height: **Euro-Norm 60 cm**Niche height: **590 mm - 600 mm**Niche width: **min. 560 mm**Niche depth: **min. 550 mm**Niche dimensions (H x W x D): **min. 590-600 x 560 x 550 mm**Unit width in mm : **590 mm**Unit height in mm: **595 mm**Unit depth in mm: **549 mm****Packaging**Weight, incl. packaging: **50 kg**

Packaging dimensions (H x W x D):

Samsung BO20 Dual Door Oven (Dual Cook Flex) > Web link

656 x 682 x 645 mm

Accessory

Included accessories



> Weblink
500.000.046.00 / CHF
880.-
Cooking chamber divider

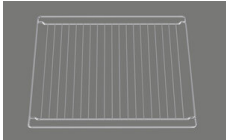

> Weblink
500.000.042.00 / CHF
880.-
Grid

Optional accessories



> Weblink
500.000.040.00 / CHF
88.-
Extra deep baking sheet
50 mm

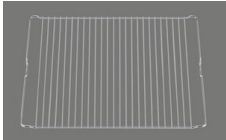

> Weblink
500.000.045.00 / CHF
49.-
Grid insert

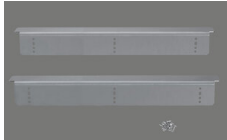

> Weblink
500.000.074.00 / CHF
60.-
Set of support brackets

Compatible Articles



> Weblink
500.000.009.00 / CHF
350.-
Drawer WS10/20/30/50

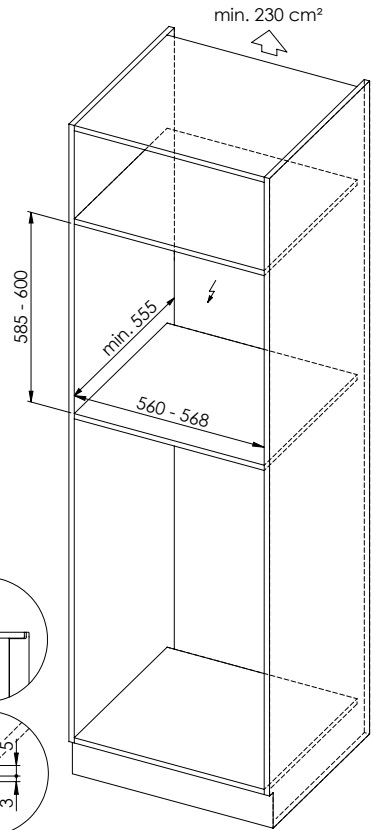
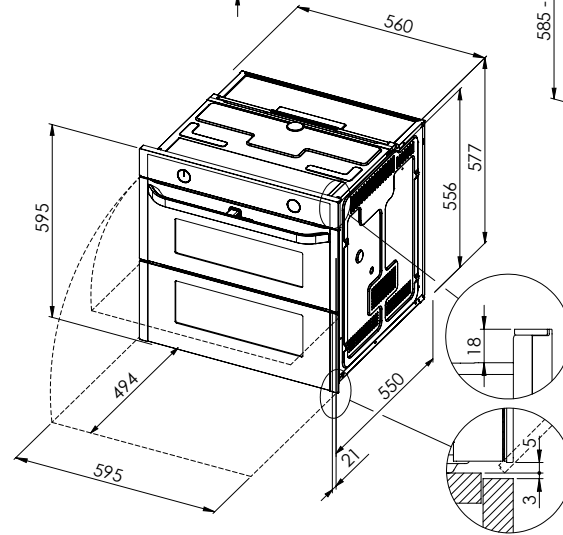
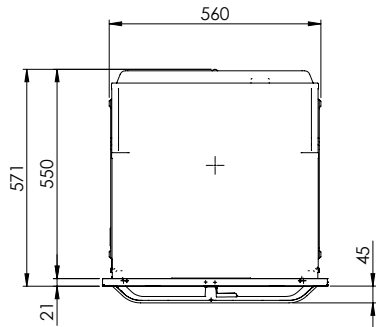
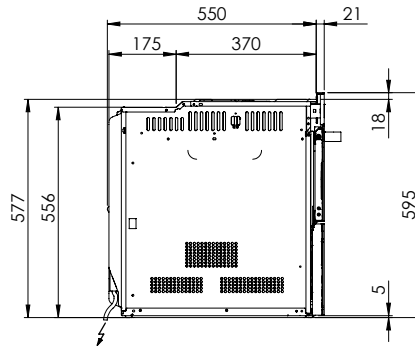
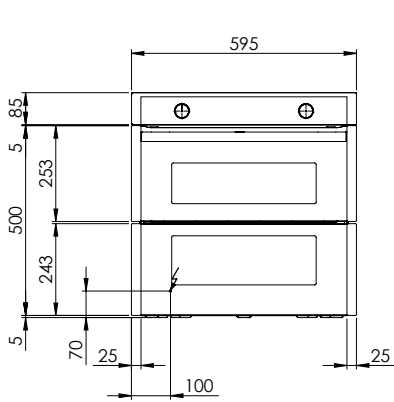

 BO20: 230 V / 16 A, Direktanschluss, Raccordement électrique, Collegamento elettrico¹

¹Anschlusskabel bauseits

Câble de raccordement fourni par le client

Cavo di collegamento fornito da parte cliente

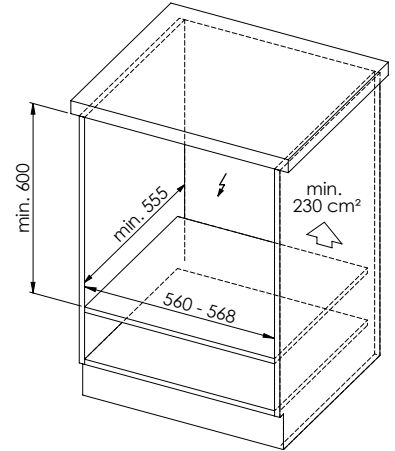
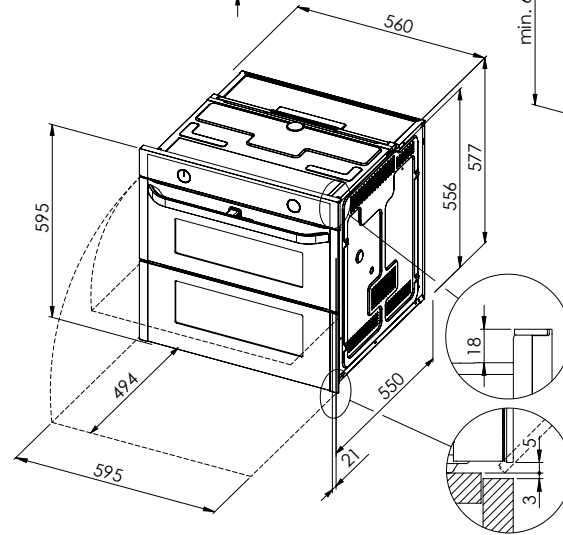
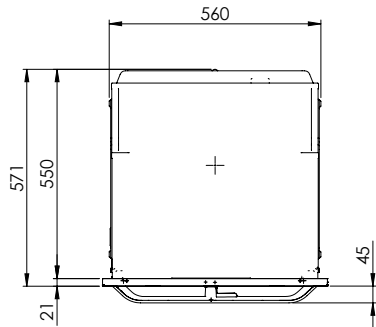
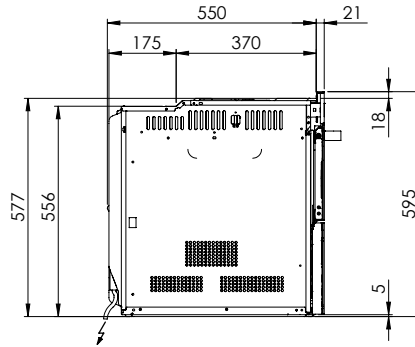
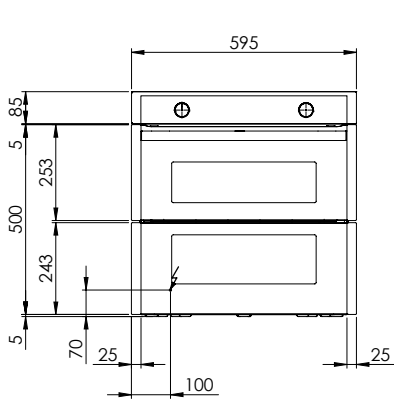

 BO20: 230 V / 16 A, Direktanschluss, Raccordement électrique, Collegamento elettrico¹

¹Anschlusskabel bauseits

Câble de raccordement fourni par le client

Cavo di collegamento fornito da parte cliente

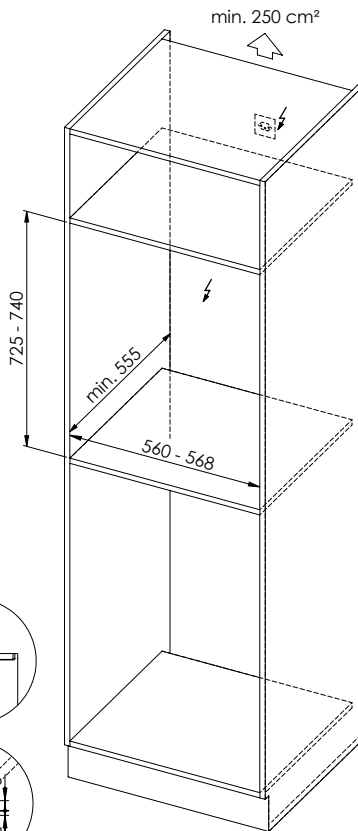
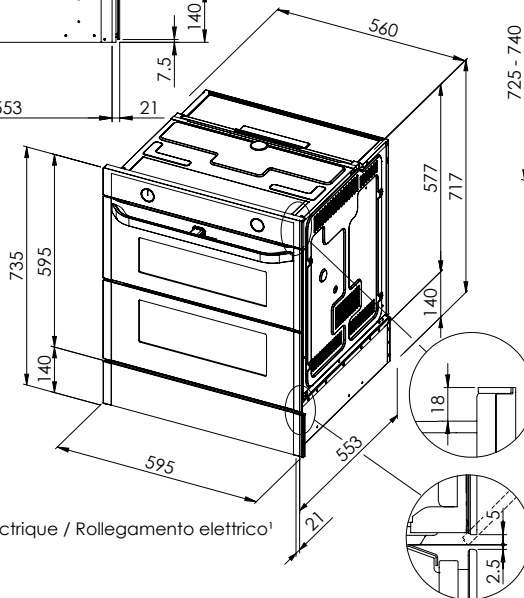
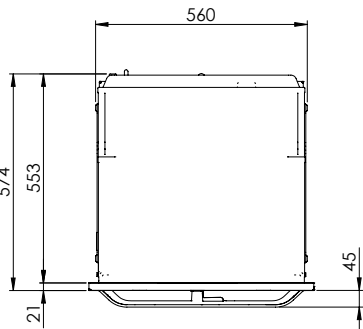
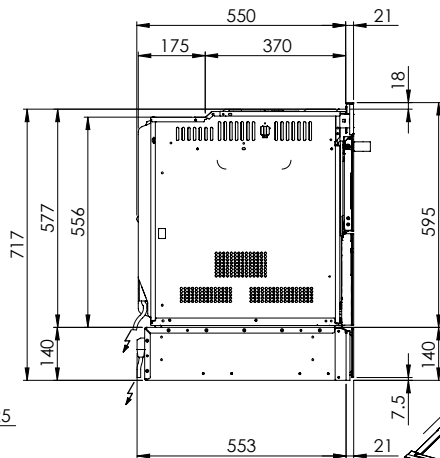
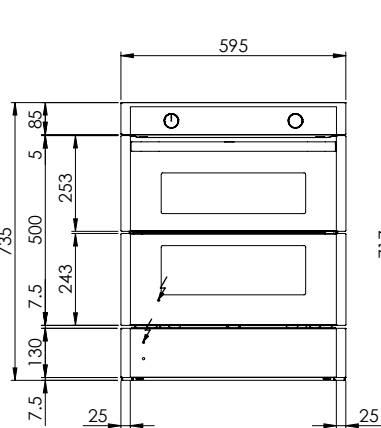

BO20: 230 V / 16 A, Direktanschluss / Raccordement électrique / Rollegamento elettrico'
 WS10/20/30/50: 230 V / 10 A, T12, 1500 mm

'Anschlusskabel bauseits
 Câble de raccordement fourni par le client
 Cavo di collegamento fornito da parte cliente

Samsung BO20 & WS10/20/30/50

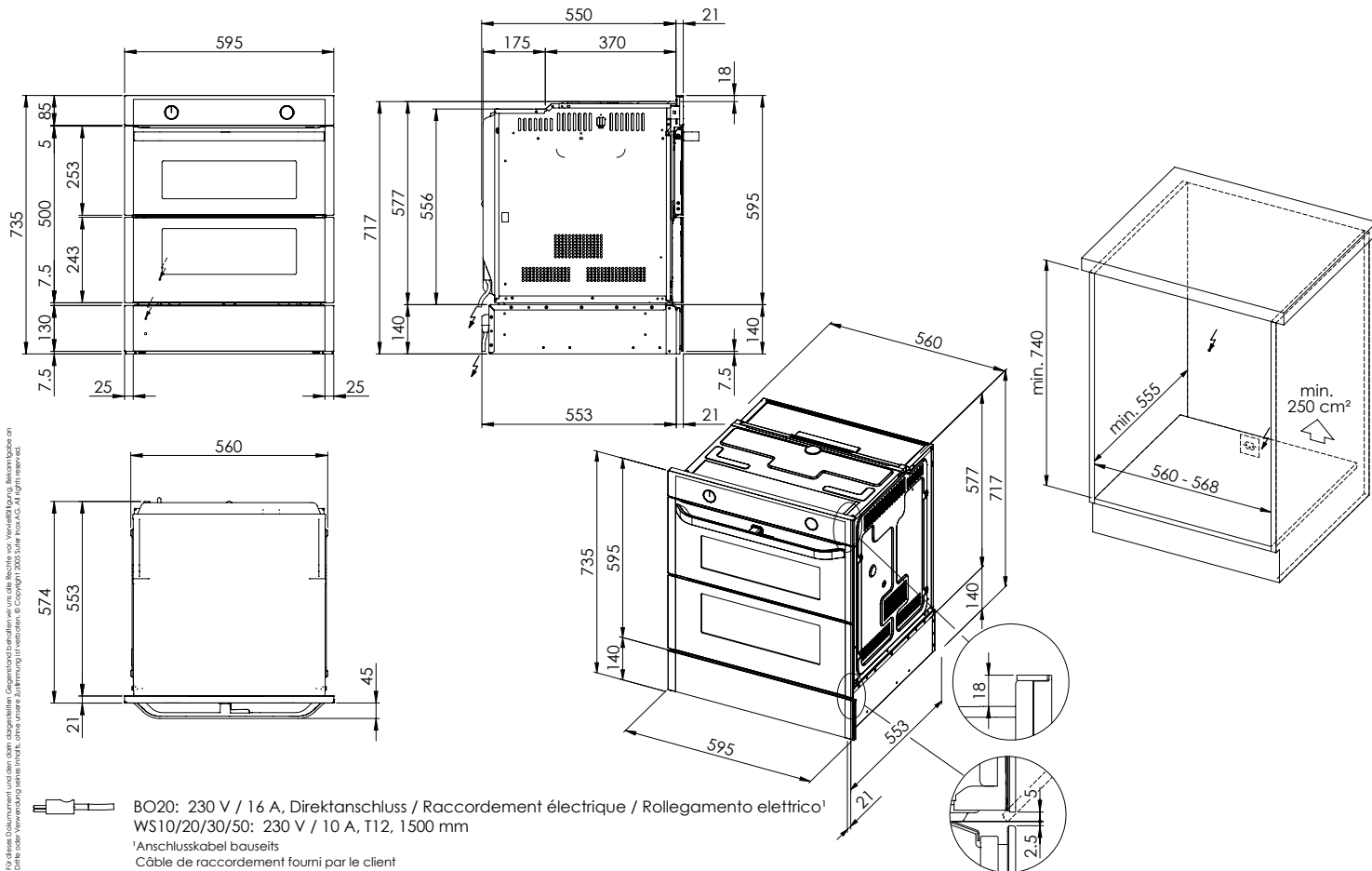

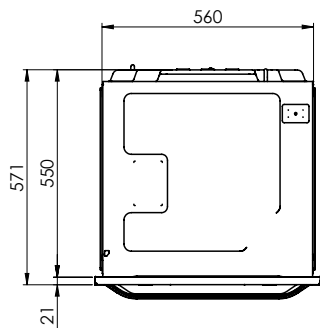
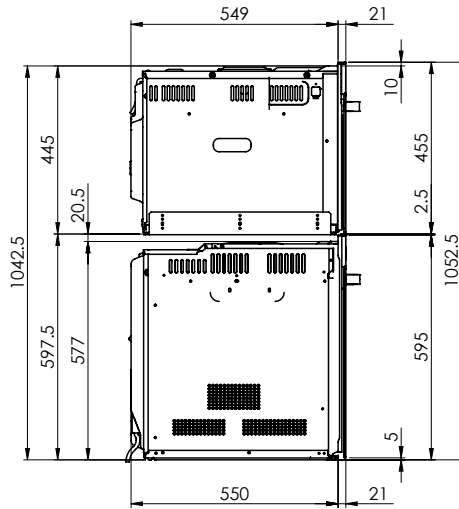
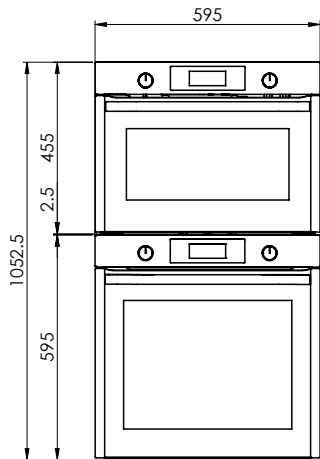

Bei Mehrgerätemontage übereinander: Berücksichtigen Sie bei der Planung der Elektroanschlüsse die jeweiligen Gerätespezifikationen.
 Montage de plusieurs appareils l'un sur l'autre: veuillez tenir compte des spécifications de chaque appareil lors de la planification des raccordements électriques.
 Montaggio in colonna di più apparecchi: nella pianificazione degli allacciamenti elettrici, attenersi alle specifiche dei rispettivi apparecchi.

Es ist das Nachwendrecht vorbehalten, dieses Diagramm, Gegenstandsbezeichnungen und alle Rechte vor, Nach und Nebenher zu übertragen. Dieses Nachwendrecht ist vorbehalten, ohne unsere Zustimmung zu übertragen. © Copyright 2003 Suter Inox AG. All rights reserved.

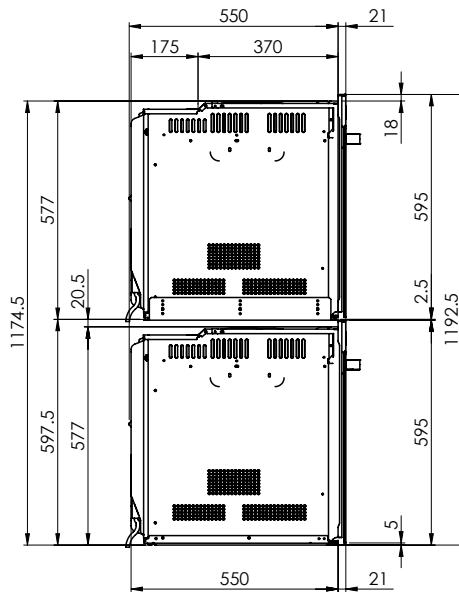
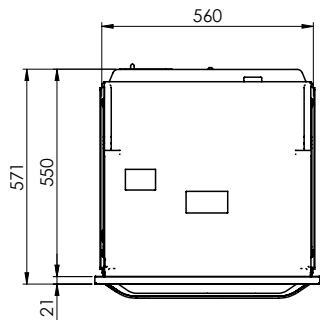
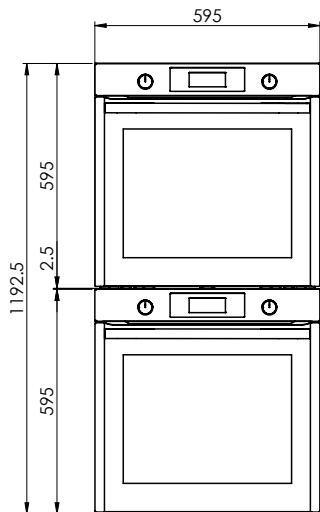

Bei Mehrgerätemontage übereinander: Berücksichtigen Sie bei der Planung der Elektroanschlüsse die jeweiligen Gerätespezifikationen.
 Montage de plusieurs appareils l'un sur l'autre: veuillez tenir compte des spécifications de chaque appareil lors de la planification des raccordements électriques.
 Montaggio in colonna di più apparecchi: nella pianificazione degli allacciamenti elettrici, attenersi alle specifiche dei rispettivi apparecchi.

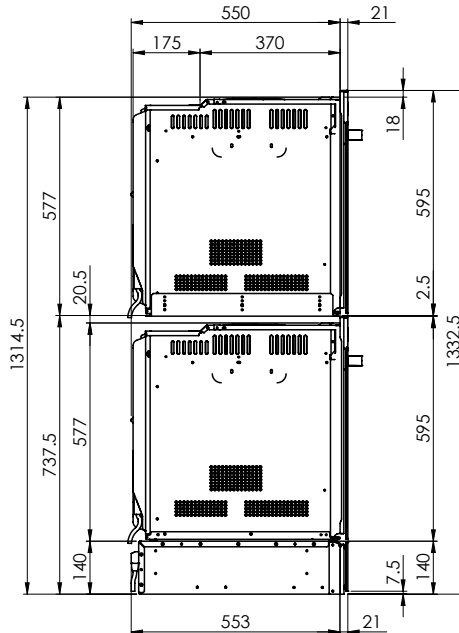
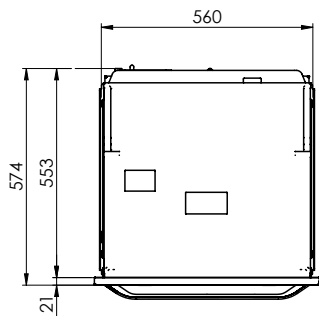
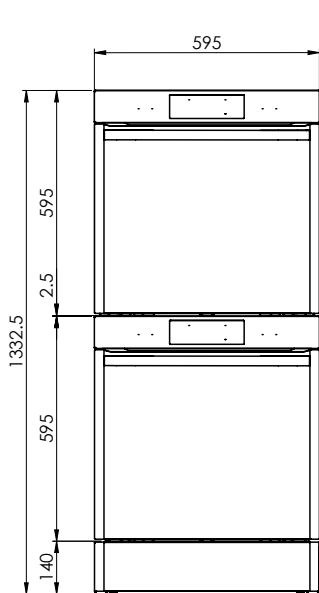

Bei Mehrgerätemontage übereinander: Berücksichtigen Sie bei der Planung der Elektroanschlüsse die jeweiligen Gerätespezifikationen.
 Montage de plusieurs appareils l'un sur l'autre: veuillez tenir compte des spécifications de chaque appareil lors de la planification des raccordements électriques.
 Montaggio in colonna di più apparecchi: nella pianificazione degli allacciamenti elettrici, attenersi alle specifiche dei rispettivi apparecchi.

