

Samsung BO60 Dual Fan Oven

[> Web link](#)

Model
Samsung BO60 Dual Fan Oven

Energy efficiency class
A

Manufacturer ID
NV70K2340RB/EO

Article no.
500.000.004.00

Appliance type
Ovens

Construction
Euro Norm 60 cm

VRG
10.00

Price CHF
1'106.- excl. VAT

Highlights

- 20 automatic programs
- 73 L cooking capacity
- Dual fan with double hot air: to cook fast, efficient and consistent
- Self-cleaning: catalysis and steam
- Cooking chamber with ceramic enamel: scratch-proof, anti-bacterial
- Easy to operate: retractable knob and sensor buttons

Product description

Construction: **Euro-Norm 60 cm**
GTIN-Nr.: **8806088179247**

Efficiency and consumption

Energy efficiency class (from A+++ to D): **A**

Energy efficiency index: **94**

Energy consumption

Energy consumption, conventional (kWh / cycle): **0,99 kWh**

Energy consumption, convection / hot air (kWh / cycle): **0,79 kWh**

Standby consumption: **0,9 W**

Consumption pyrolytic cleaning process (kWh / cycle): -

Design

Color control panel: **Black**

Material control panel: **Glass**

Frame / material: - / -

Display and operation

Display: **Digital display**

Display and lighting: **LED, ice blue**

Operation: **Retractable knob, buttons**

Interconnection of household appliances

Samsung Smart Home: -

Performance properties

max. adjustable temperature for top / bottom heat, convection / hot air: **250°C**

Temperature for steam operation:--

Microwave power output -

Useable grilling space : **1912 cm²**

Useable oven capacity: **70 L**

Dimensions

Height: **59.5 cm**

Width: **59.5 cm**

Depth: **54.5 cm**

Depth (from front of unit): **56.6 cm**

Depth with open door (in front of unit): **49.4 cm**

Unit dimensions (H x W x D) : **595 x 595 x 545 mm**

Empty weight

Unit weight: **34.2 kg**

Fittings

Inside dimensions (useable size) mm (height / width / depth): **375 x 465 x 397 mm**

Top and bottom heat: **Yes / Yes**

Convection:-

Hot air: **Yes**

Steam:

Samsung BO60 Dual Fan Oven

[> Web link](#)

-
 Microwave: -
 Catalytic cleaning aid : **Yes**
 Pyrolytic cleaning aid : -
 Grill heating element available / retrofittable: **Yes / -**
 Grill motor / convection grilling: -
 Timer switch / timer: **Yes**
 Drawer / warming drawer: - / **optional**
 Number of cooking chambers: **1**
 Volume per cooking chamber
 Single-chamber operation / top cooking chamber / bottom cooking chamber: **70 L / - / -**
 Number of shelf levels: **5**
 Lighting / inspection window: **Yes / Yes**
 Lighting : **1 x 25W, halogen**
 Telescope rails: **Single**
 Cleaning: **Catalysis, steam cleaning**
 Cooling process: **Cooling ventilator**
 Interior lining: **Ceramic enamel**

Operating modes

Steam: -
 Steam + heating: -
 Steam + hot air: -
 Steam + top heat + hot air:-
 Steam + bottom heat + hot air: -
 Top / bottom heat: **30-250°C**
 Hot air: **30-250°C**
 Hot air ECO: **30-250°C**
 Grill: large / eco / convection: **100-250°C / 100-250°C / -**
 Bottom heat + hot air: **40-250°C**
 Top heat + hot air: **40-250°C**
 Bottom heat : **100-230°C**
 Fast cooking: -
 Automatic roasting (ProRoasting) : **80-200°C**
 Microwave + grill: -
 Microwave + hot air: -

Programs

Special functions: **Multi-level mode**
 Automatic programs: **20**
 Dual Cook: -

Control functions

Control functions: **Cooking time, kitchen timer, child safety, multi-level mode**

Capacity

Total capacity: **3400-3600 W**
 Hot air : **1700 W**
 Top heat : **1600 / 1100 W**
 Bottom heat : **1100 W**
 Grill max. / min.: **1600 / 1100 W**
 Large-sized grill: **1600 W**
 Steam:-
 Microwave:-

Electrical connection

Supply voltage g: **230 V**
 Frequency : **50 Hz**
 Connection values: **3.4-3.6 kWh**
 Fuse protection: **16 A**
 Length power connection: **1,4 m**
 Power plug: **Schuko safety plug with CH adapter (16 A, type 23)**

Technical data

Standard width: **Euro-Norm 60 cm**
 Standard height: **Euro-Norm 60 cm**
 Niche height: **590 mm - 600 mm**
 Niche width: **min. 560 mm**
 Niche depth: **min. 550 mm**
 Niche dimensions (H x W x D): **min. 590-600 x 560 x 550 mm**
 Unit width in mm : **595 mm**
 Unit height in mm: **595 mm**
 Unit depth in mm: **545 mm**

Packaging

Weight, incl. packaging: **36.5 kg**
 Packaging dimensions (H x W x D): **646 x 682 x 656 mm**

Samsung BO60 Dual Fan Oven > Web link

Accessory

Included accessories

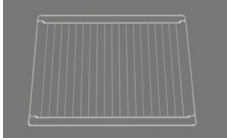

> Weblink
500.000.042.00 / CHF 1.-
Grid

Optional accessories



> Weblink
500.000.040.00 / CHF
88.-
Extra deep baking sheet
50 mm

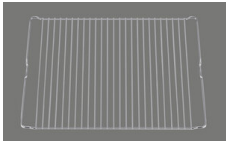

> Weblink
500.000.045.00 / CHF
49.-
Grid insert

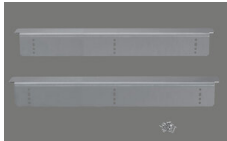

> Weblink
500.000.074.00 / CHF
60.-
Set of support brackets

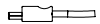
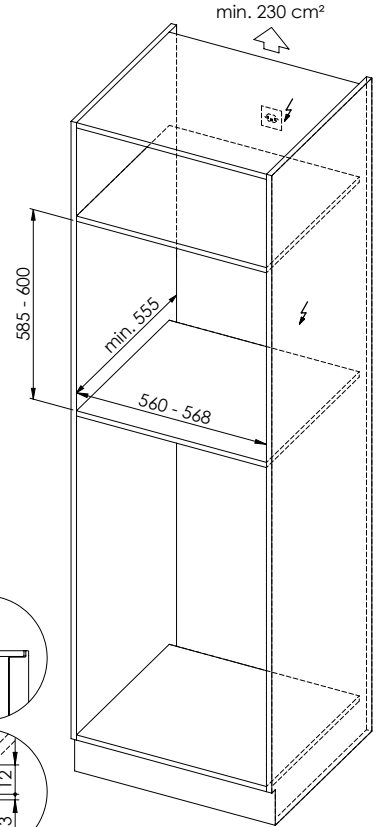
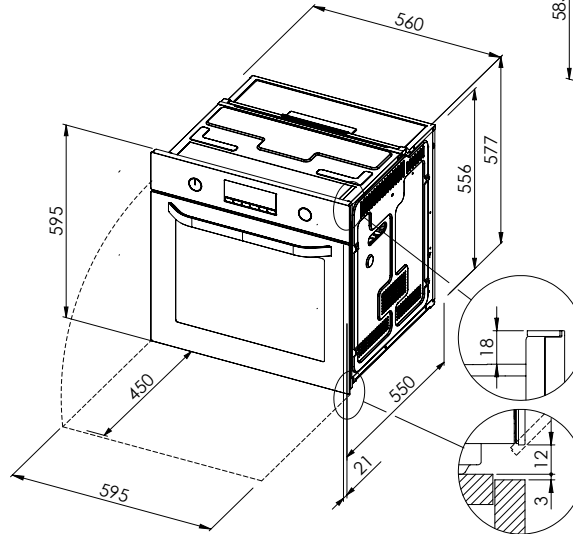
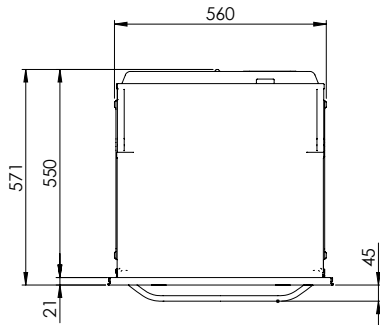
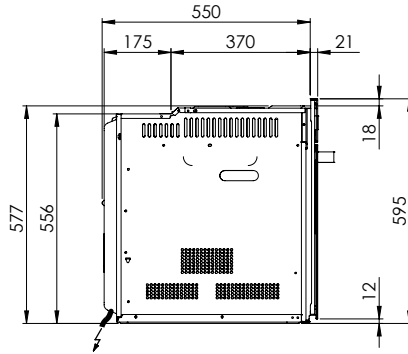
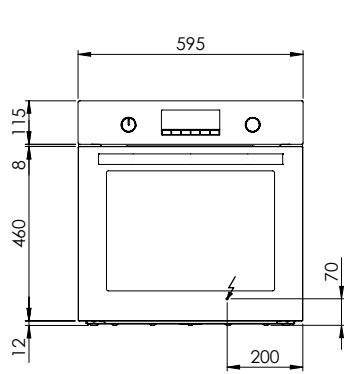

BO60¹: 230 V / 16 A, T23, 1400 mm

¹Direktanschluss möglich (Anschlusskabel bauseits)

Raccordement électrique direct possible (câble de raccordement fourni par le client)

Collegamento elettrico diretto possibile (cavo di collegamento fornito da parte cliente)

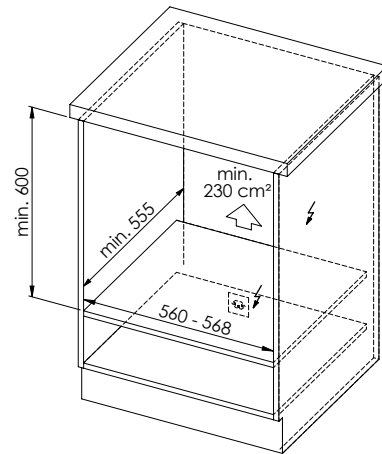
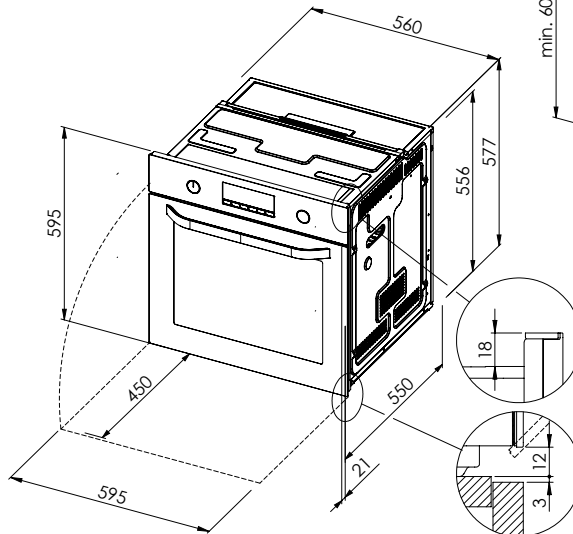
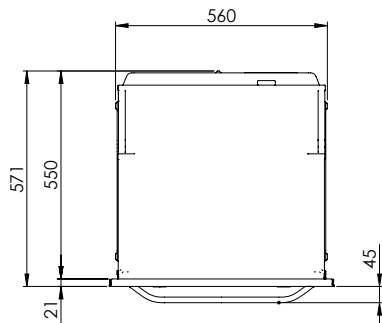
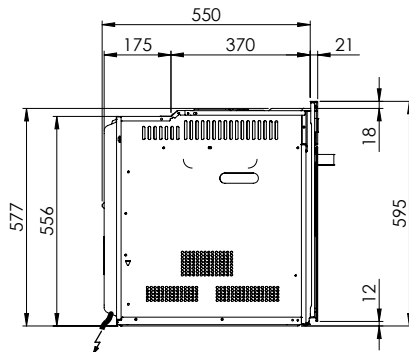
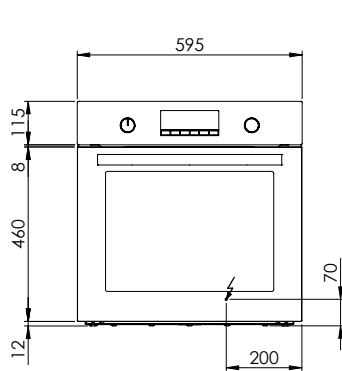

BO60¹: 230 V / 16 A, T23, 1400 mm

¹Direktanschluss möglich (Anschlusskabel bauseits)

Raccordement électrique direct possible (câble de raccordement fourni par le client)

Collegamento elettrico diretto possibile (cavo di collegamento fornito da parte cliente)

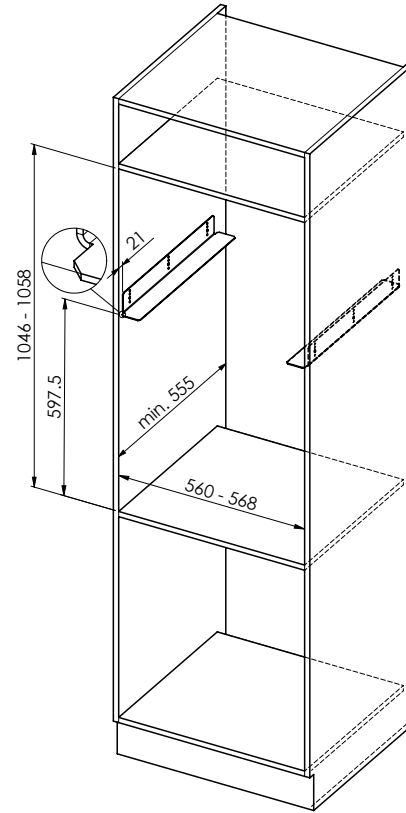
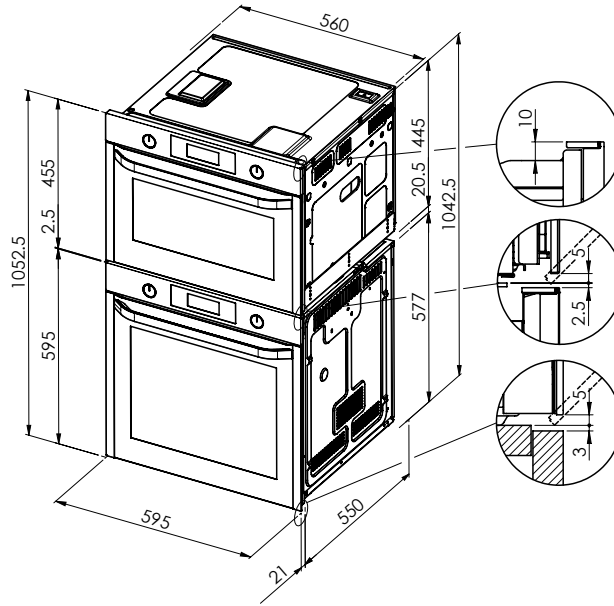

Bei Mehrgerätemontage übereinander: Berücksichtigen Sie bei der Planung der Elektroanschlüsse die jeweiligen Gerätespezifikationen.
 Montage de plusieurs appareils l'un sur l'autre: veuillez tenir compte des spécifications de chaque appareil lors de la planification des raccordements électriques.
 Montaggio in colonna di più apparecchi: nella pianificazione degli allacciamenti elettrici, attenersi alle specifiche dei rispettivi apparecchi.

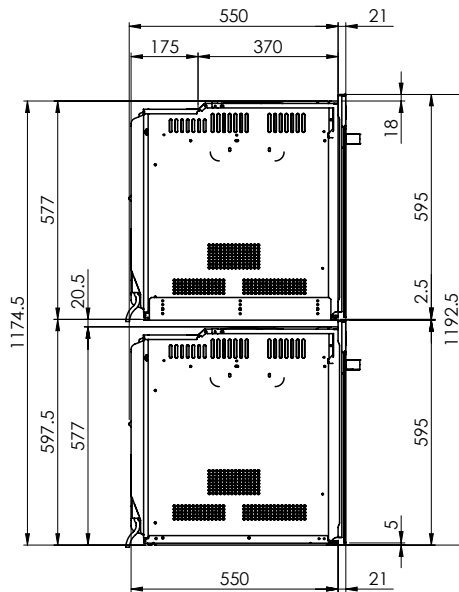
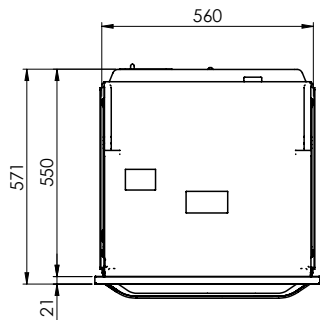
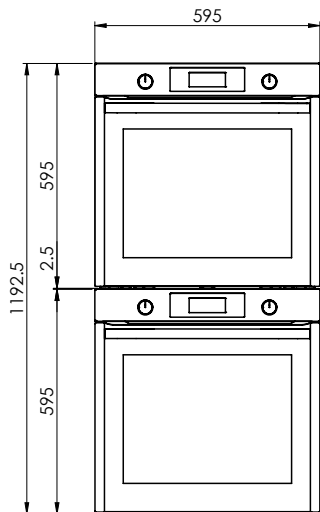

Bei Mehrgerätemontage übereinander: Berücksichtigen Sie bei der Planung der Elektroanschlüsse die jeweiligen Gerätespezifikationen.
 Montage de plusieurs appareils l'un sur l'autre: veuillez tenir compte des spécifications de chaque appareil lors de la planification des raccordements électriques.
 Montaggio in colonna di più apparecchi: nella pianificazione degli allacciamenti elettrici, attenersi alle specifiche dei rispettivi apparecchi.

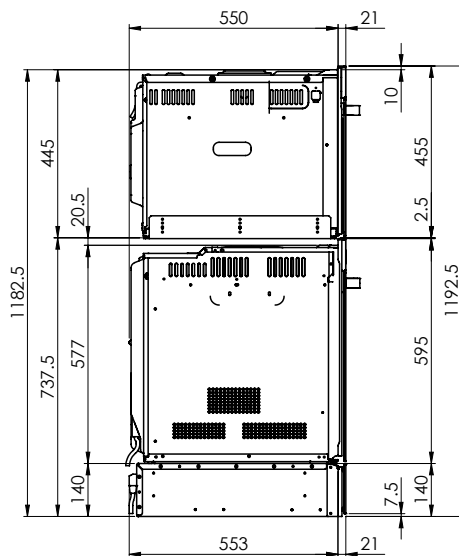
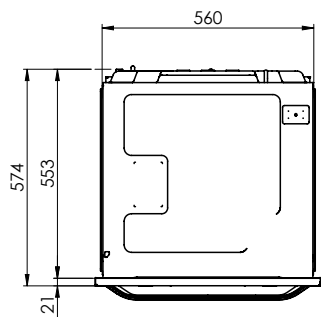
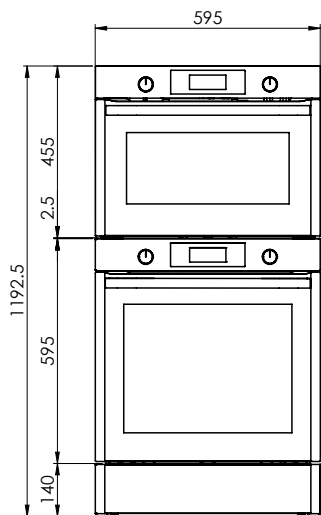

Bei Mehrgerätemontage übereinander: Berücksichtigen Sie bei der Planung der Elektroanschlüsse die jeweiligen Gerätespezifikationen.
 Montage de plusieurs appareils l'un sur l'autre: veuillez tenir compte des spécifications de chaque appareil lors de la planification des raccordements électriques.
 Montaggio in colonna di più apparecchi: nella pianificazione degli allacciamenti elettrici, attenersi alle specifiche dei rispettivi apparecchi.

