

## Samsung Built-in refrigerator and freezer combination EKG20

[> Web link](#)

**Model**  
Samsung Built-in refrigerator and freezer combination  
EKG20

**Energy efficiency class**  
A++

**Manufacturer ID**

**Article no.**  
500.000.021.00

**Door hinge**  
Right

**Construction**  
Euro Norm 60 cm

**VRG**  
26.00

**Price CHF**  
1'253.- excl. VAT

## Highlights

- Digital Inverter compressor - 10-year warranty
- NoFrost+ technology in refrigerator and freezer - the end of de-icing
- Metal Cooling - to prevent cold air from escaping
- Precise Cooling - for maximum temperature accuracy
- All Around Cooling - consistent temperature in the cooling chamber
- 1 vegetable drawer / 3 glass shelves
- 1 Fresh Zone drawer
- 266 litres useable capacity

## Product description

Construction: **Euro Norm 60 cm**  
GTIN-Nr.: **8806088593258**

**Model classification**

Energy efficiency class (from A+++ to D): **A++**  
Energy consumption per year: **240 kWh**

**Design**

Colour/material: **White**  
Door handles: -

**Display and operation**

Display: **Digital display**  
Display and lighting: **LED, ice blue**  
Operation: **Touch LCD**

**Interconnection of household appliances**

Samsung Smart Home: -

**Performance properties**

**Total useable capacity: 266 L**

Of which NoFrost: **266 L**

**Useable capacity refrigerator: 194 L**

Of which cellar refrigeration max./min.: -

Of which cold storage compartment: -

**Useable capacity freezer: 72 L**

Freezing capacity: **9 kg in 24 hours**

Storage time in case of outage: **14 hours**

Sound power level: **38 dB(A)**

Climate class: **SN N ST T**

Ambient temperature (min. > max.): **von +10°C bis +43°C**

De-icing process refrigerator: **Automatic**

De-icing process freezer: **Automatic**

**Construction and identification**

Stand-alone unit: -

Built-in unit: **Yes**

Undermount unit: -

Integral: **Yes**

Number of outside doors/pull-outs: **2**

Door hinge: **right (reversible)**

**Dimensions**

Height: **177.5 cm**

Width: **54.0 cm**

Depth: **55.0 cm**

Width with open door/pull-out:

**Samsung Built-in refrigerator and freezer combination EKG20**[> Web link](#)**70 cm**Depth with open door/pull-out: **105.5 cm**Dimensions of unit (H x W x D) : **1775 x 540 x 550 mm****Empty weight**Unit weight: **61 kg****Fittings****Adjustable freezer temperature**Independent of refrigerator temperature: **Yes**

Together with refrigerator temperature: -

Control for continuous freezer operation: -

**Control indicators refrigerator**Regular operation: **Lamp**Temperature indicator: **Inside**Door open: **Acoustic after 2 min.****Control indicators freezer**Regular operation: **Lamp**Continuous operation: **Lamp**Malfunction / warning signal: **Visual / acoustic**Door open: **Warning signal, acoustic**Temperature indicator: **Inside****Refrigerator**Egg trays: **6**Door compartments with flap or sliding door: **1**Door shelves and/or containers: **5**Refrigerator storage surfaces: **3**- - of which adjustable: **2**Refrigerator containers: **2****Freezer**

Door compartments: -

Interior compartments: **1**Baskets, containers, interior drawers: **2**Ice cube trays: **Yes****Additional fittings**

Door water and ice dispenser: -

ClearView ice maker: -

Water filter: -

Interior lighting: **LED**Fruit and vegetable compartments: **2**

Fully retractable drawers : -

Fresh Zone compartments: **1**Pull-out tray: **1**Wine cooler: **Yes / 5 bottles**

Water connection: -

**Cooling technology**Digital inverter compressor: **Yes**NoFrost+ technology: **Yes**

Cool Select Plus: -

All Around Cooling (multi-flow): **Yes**Metal Cooling: **Yes**

Twin Cooling Plus: -

Flex zone: -

Refrigerant: **R-600a****Power and water supply****Electrical connection**Supply voltage: **230 V**Frequency: **50 Hz**Connection values: **160 W**Fuse protection: **1.4 A**Length power connection: **2.5 m**Power plug **Plug type 12, 10 A****Water connection**

Water connection: -

Pressure hose G 3/4": -

Connectable to: -

Connectable to cold/hot water: -

Water pressure: -

Water inlet: -

Water outlet: -

**Technical data**Standard width: **Euro Norm 60 cm**

Standard height: -

Niche height: **1778 - 1782 mm**Niche width: **560 - 562 mm**

Niche depth: -

## Samsung Built-in refrigerator and freezer combination EKG20

[> Web link](#)

### 560 - 580 mm

Niche dimensions (H x W x D): **1778 - 1782 mm x 560 - 562 mm x 560 - 580 mm**

Max. door front weight refrigerator/freezer: **18 kg / 12 kg**

Material thickness door front: **min. 16 mm / max. 19 mm**

Unit height: **1775 mm**

Unit width: **540 mm**

Unit depth: **550 mm**

### Packaging

Weight, incl. packaging: **63.5 kg**

Packaging dimensions (H x W x D): **1864 x 580 x 628 mm**

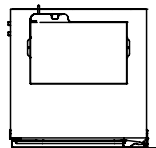
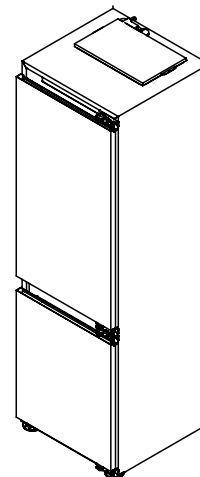
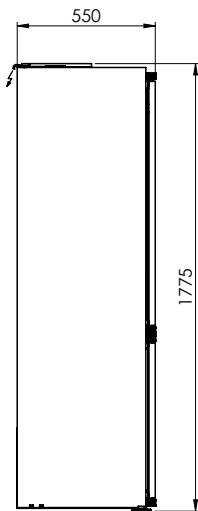
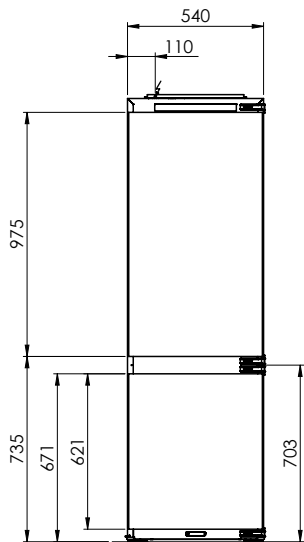

EKG20: 230 V / 10 A, T12, 2500 mm

Für diese Zeichnung sind alle Rechte vorbehalten. Alle Rechte vorbehalten. Verwendet für die Zwecke der Veranschaulichung. Keine Haftung für die Darstellung. Die Verwendung dieser Zeichnung ist ohne unsere Zustimmung ist verboten. © Copyright 2003 Suter Inox AG. All rights reserved.

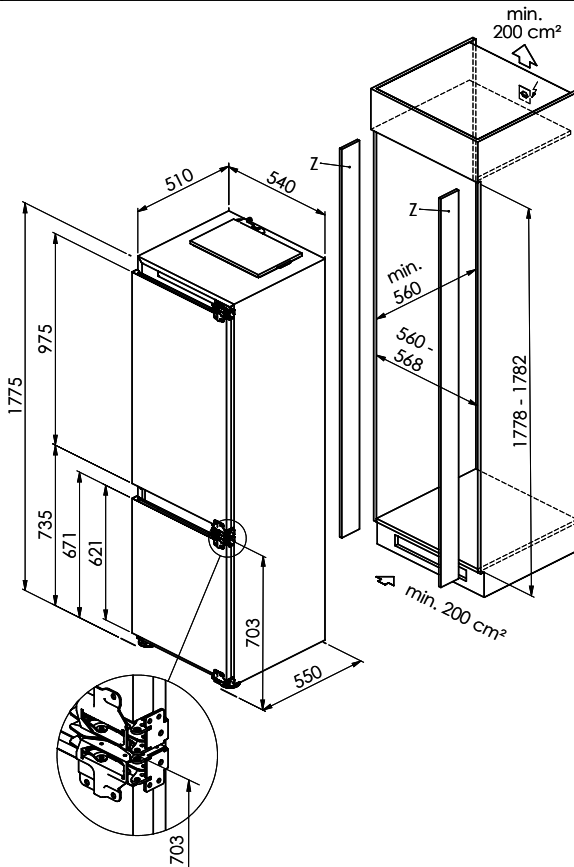
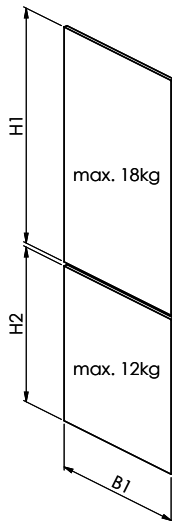
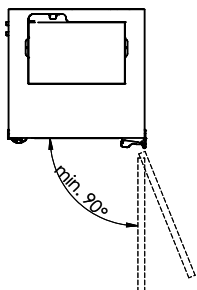
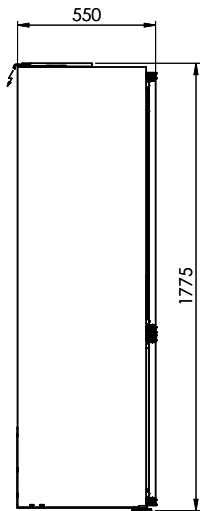
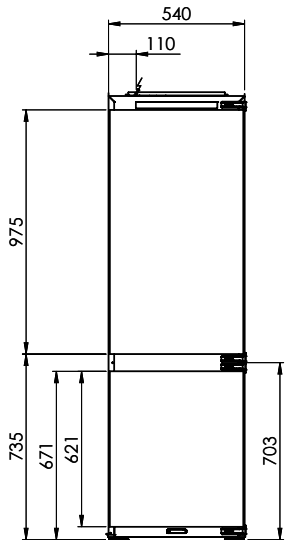

EKG20: 230 V / 10 A, T12, 2500 mm <sup>2</sup>Montagezubehör siehe: [www.suter.ch](http://www.suter.ch)