

Daneo DAN 100-50IF

[> Web link](#)



Fitting style
Flushmount sinks / Flat-mount inset

Model
DAN 100-50IF

Material
Stainless steel 18/10

Article no.
10.103.591.00

Cabinet size
55 cm

Basket
3½" TouchFlow

Surface
Matt

VRG
0.19

Price CHF
2'284.- excl. VAT

Dimensions
500x400x188mm

Corner radius
22 mm

Drainboard
Right

Overflow and drain technology



Sieve - type S



Swivelling TouchFlow overflow cap

Basket pre-assembly
Assembly of the valve at the factory

Dispenser - mounting option
Free choice of positioning

Overflow and drain technology
Standard pull-up knob

Prices (as of 20.06.26/excl. VAT)

Model	Material	Basket	Drainboard	Article no.	Price CHF
Daneo DAN 100-50IF	Stainless steel 18/10, Matt	3½" Tipo	Left	10.103.590.00	2'045.- > Weblink
		3½" Tipo	Right	10.103.593.00	2'045.- > Weblink
		3½" Space-saving	Left	10.103.589.00	2'086.- > Weblink
		3½" Space-saving	Right	10.103.592.00	2'086.- > Weblink
		3½" TouchFlow	Left	10.103.588.00	2'284.- > Weblink
		3½" TouchFlow	Right	10.103.591.00	2'284.- > Weblink

Product description

1 Product Model, 2 Installation Types

The special advantage of IF models: Installation as flush with the adjacent areas as well as laid flat on top is possible.

Flush-mounted installation: Recommendation for the choice of worktop:

We recommend installation in worktops made of ceramic, granite, artificial stone (e.g. Corian or Varicor) or solid wood. We do not recommend installation in coated chipboard.

Accessory

Optional accessories



> Weblink
40.000.912.00 / CHF 106.-
Colander, perforated



> Weblink
40.001.289.00 / CHF 106.-
Colander, unperforated

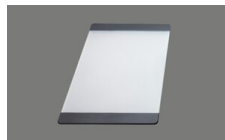

> Weblink
40.000.909.00 / CHF 151.-
Chopping board, made of glass, white

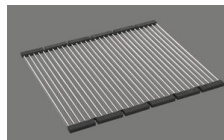

> Weblink
40.001.140.00 / CHF 125.-
Inox Pad

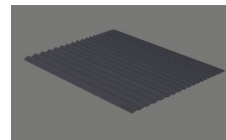

> Weblink
40.002.008.00 / CHF 51.-
Maro dish drainer mat, Dark Grey

Daneo DAN 100-50IF > [Web link](#)

Spares

You can find the compatible range of spares here > [Weblink](#)

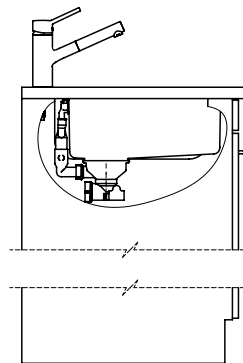
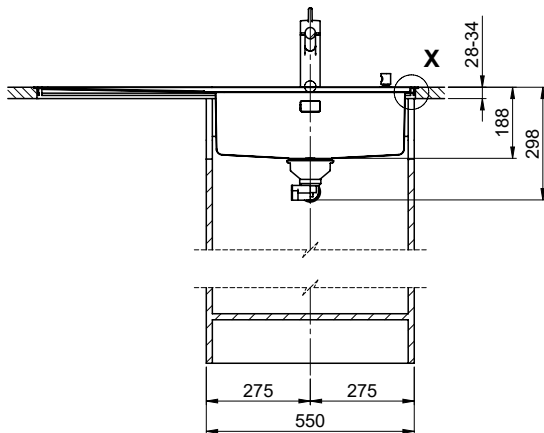

Für dieses Dokument und den darin abgezeichneten Gegenstand behalten wir uns alle Rechte vor. Verwendung, Belassung an
 Dritte oder Vervielfältigung ohne unsere schriftliche Zustimmung ist verboten. © Copyright 2020 Suter Inox AG. Alle Rechte vorbehalten.

Daneo DAN 100-50IF sFlow Typ S, Tropfteil links
 Daneo DAN 100-50IF sFlow Typ S, égouttoir à gauche
 Daneo DAN 100-50IF sFlow Typ S, scolatoio a sinistra

Bohrung für Zug- und Druckknöpfe ø14
 Bohrung für Drehknopf ø25

Trou pour boutons et Pousoirs de commande ø14
 Trou pour bouton rotatif ø25

Foro per Pomelli tiranti e Pomelli pulsanti ø14
 Foro per Pomolo girevoli ø25

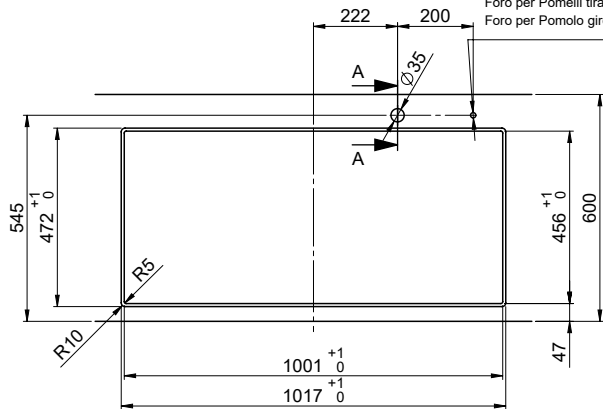

A-A (1 : 2)

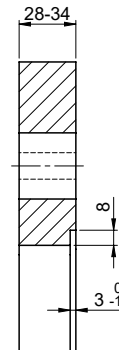

X (1:1)

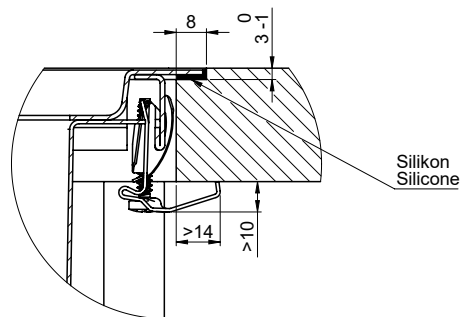

Vom flächenbündigen Einbau in beschichteten Spanplatten raten wir ab.
 Nous vous déconseillons le montage à fleur sur des panneaux de particules enduits.
 Sconsigliamo il montaggio a filo top in pannelli di truciolato laminato.

Daneo DAN 100-50IF sFlow Typ S, Tropfteil links
 Daneo DAN 100-50IF sFlow Typ S, égouttoir à gauche
 Daneo DAN 100-50IF sFlow Typ S, scololetto a sinistra

Bohrung für Zug- und Druckknöpfe $\varnothing 14$
 Bohrung für Drehknopf $\varnothing 25$

Trou pour boutons et Pousoirs de commande $\varnothing 14$
 Trou pour bouton rotatif $\varnothing 25$

Foro per Pomelli tiranti e Pomelli pulsanti $\varnothing 14$
 Foro per Pomolo girevoli $\varnothing 25$

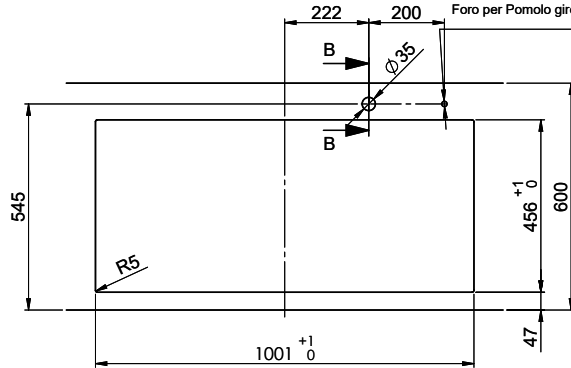

B-B (1 : 2)



X (1:1)

