

Daneo DAN 110-50IF

[> Web link](#)



Fitting style
Flushmount sinks / Flat-mount inset

Model
DAN 110-50IF

Material
Stainless steel 18/10

Article no.
10.103.981.00

Cabinet size
55 cm

Basket
3½" Space-saving

Surface
Matt

Price CHF
2'158.- excl. VAT

Dimensions
500x400x190mm

Corner radius
22 mm

Drainboard
Left

Overflow and drain technology



Sieve - type S



Swivelling overflow cap

Basket pre-assembly
Assembly of the valve at the factory

Dispenser - mounting option
Free choice of positioning

Overflow and drain technology
Standard pull-up knob



Advant

Prices (as of 21.06.26/excl. VAT)

Model	Material	Basket	Drainboard	Article no.	Price CHF
Daneo DAN 110-50IF	Stainless steel 18/10, Matt	3½" Tipo	Left	10.103.964.00	2'117.- > Weblink
		3½" Tipo	Right	10.103.965.00	2'117.- > Weblink
		3½" Space-saving	Left	10.103.981.00	2'158.- > Weblink
		3½" Space-saving	Right	10.103.982.00	2'158.- > Weblink
		3½" TouchFlow	Left	10.103.962.00	2'356.- > Weblink
		3½" TouchFlow	Right	10.103.963.00	2'356.- > Weblink

Product description

1 Product Model, 2 Installation Types

The special advantage of IF models: Installation as flush with the adjacent areas as well as laid flat on top is possible.

Flush-mounted installation: Recommendation for the choice of worktop:

We recommend installation in worktops made of ceramic, granite, artificial stone (e.g. Corian or Varicor) or solid wood. We do not recommend installation in coated chipboard.

Accessory

Optional accessories



> Weblink
40.000.912.00 / CHF 106.-
Colander, perforated



> Weblink
40.001.289.00 / CHF 106.-
Colander, unperforated

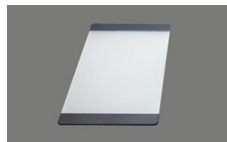

> Weblink
40.000.909.00 / CHF 151.-
Chopping board, made of glass, white

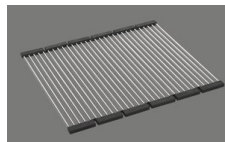

> Weblink
40.001.140.00 / CHF 125.-
Inox Pad

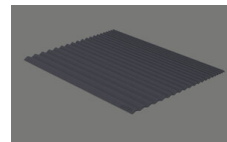

> Weblink
40.002.008.00 / CHF 51.-
Maro dish drainer mat, Dark Grey

Spares

You can find the compatible range of spares here > [Weblink](#)

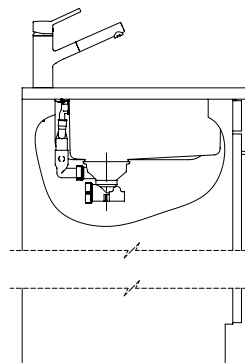
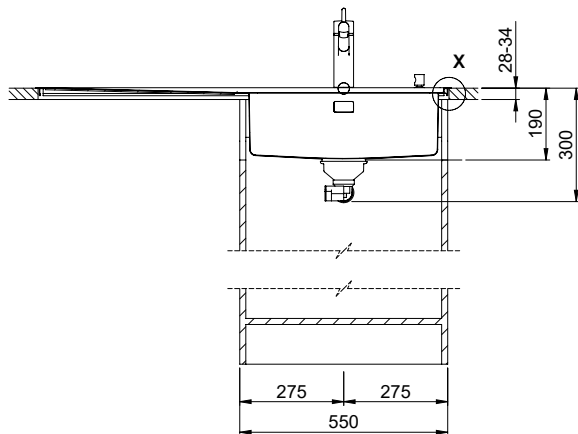
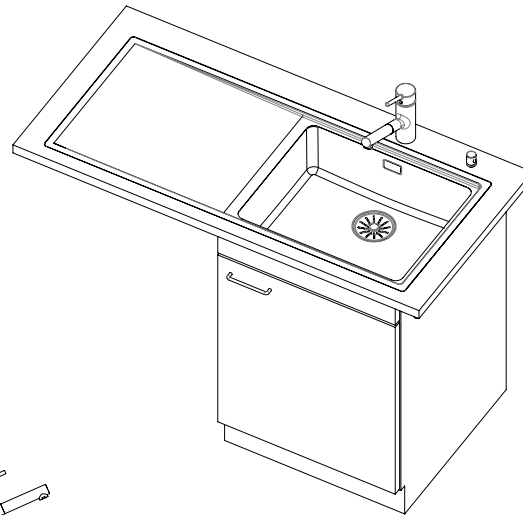
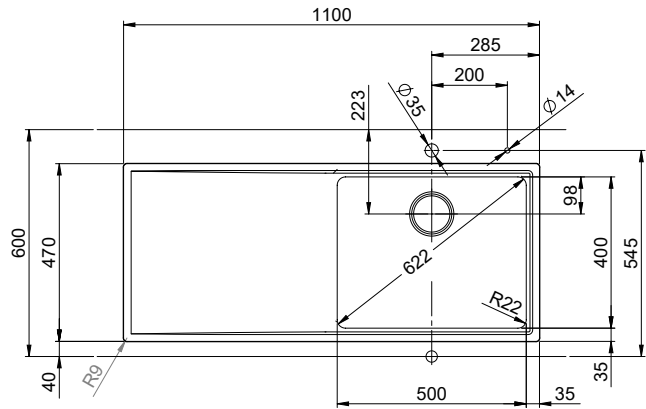

Daneo DAN 110-50IF sFlow Typ S, Tropfteil links
 Daneo DAN 110-50IF sFlow Typ S, égouttoir à gauche
 Daneo DAN 110-50IF sFlow Typ S, scolatoio a sinistra

Bohrung für Zug- und Druckknöpfe ø14
 Bohrung für Drehknopf ø25

Trou pour boutons et Pousoirs de commande ø14
 Trou pour bouton rotatif ø25

Foro per Pomelli tiranti e Pomelli pulsanti ø14
 Foro per Pomolo girevoli ø25

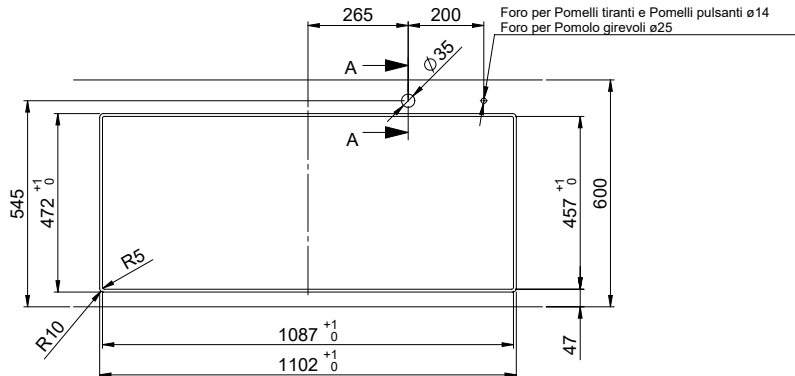

A-A (1 : 2)

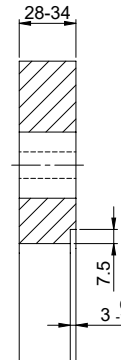

X (1:1)

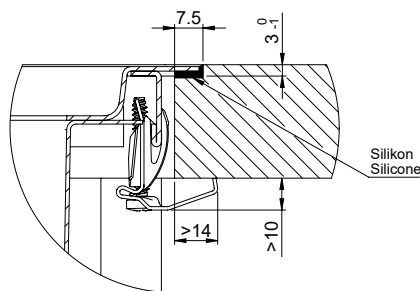

Vom flächenbündigen Einbau in beschichteten Spanplatten raten wir ab.
 Nous vous déconseillons le montage à fleur sur des panneaux de particules enduits.
 Sconsigliamo il montaggio a filo top in pannelli di truciolato laminato.

Für dieses Dokument und den darin abgesetzten Gegenstand behalten wir uns alle Rechte vor. Verwendbar für Bestimmungsinformation.
 Toute utilisation sans l'autorisation écrite de Suter Inox AG est formellement interdite.
 Tutti i diritti sono riservati. È vietata espressamente l'uso non autorizzato.

Daneo DAN 110-50IF

Ausschnitt für flach aufliegender Einbau:
Mesure de coupeure pour montage en appui:
Intaglio per montaggio sopraiano:

SUTER

Daneo DAN 110-50IF sFlow Typ S, Tropfteil links
 Daneo DAN 110-50IF sFlow Typ S, égouttoir à gauche
 Daneo DAN 110-50IF sFlow Typ S, scolatoio a sinistra

Bohrung für Zug- und Druckknöpfe ø14
 Bohrung für Drehknopf ø25
 Trou pour boutons et Pousoirs de commande ø14
 Trou pour bouton rotatif ø25
 Foro per Pomelli tiranti e Pomelli pulsanti ø14
 Foro per Pomolo girevoli ø25

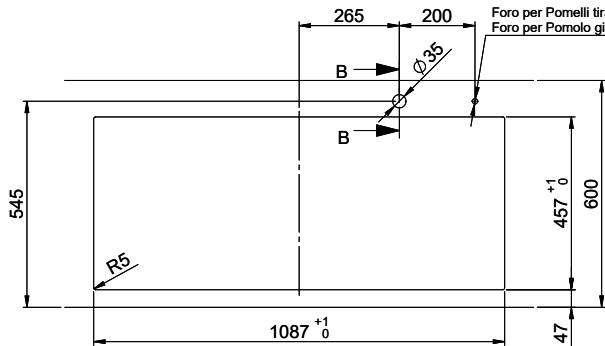

B-B (1 : 2)



X (1:1)

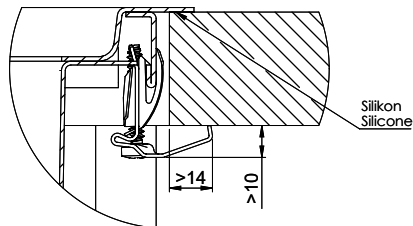

Für dieses Dokument und den darin dargestellten Gegenstand behalten wir uns alle Rechte vor. Verwertungen, Reproduktionen
 oder die Verbreitung von Teilen ohne schriftliche Zustimmung der Suter AG sind ausdrücklich untersagt. © Copyright 2020 Suter AG, All rights reserved.