

**Daneo DAN 45IF/12**

[> Web link](#)



**Fitting style**  
Flushmount sinks

**Model**  
DAN 45IF/12

**Material**  
Stainless steel 18/10

**Article no.**  
10.105.716.00

**Cabinet size**  
50 cm

**Basket**  
3½" Tipo Desino

**Surface**  
Matt

**Price CHF**  
1'094.- excl. VAT

**Dimensions**  
450x400x175mm

**Corner radius**  
22 mm

**Overflow and drain technology**



Tipo Desino:  
Concealed drain with  
basket underneath -  
type M



Swivelling overflow  
cap

**Basket pre-assembly**

Basket pre-assembly ex works

**Dispenser - mounting option**

Free choice of positioning

**Overflow and drain technology**

**Prices (as of 21.06.26/excl. VAT)**

Model	Material	Basket	Article no.	Price CHF
Daneo DAN 45IF/12	Stainless steel 18/10, Matt	3½" Tipo Desino	10.105.716.00	1'094.- > Weblink
		3½" Space-saving Desino	10.104.654.00	1'094.- > Weblink
		3½" eFlow Desino	10.104.675.00	1'419.- > Weblink
		3½" TouchFlow Desino	10.104.653.00	1'304.- > Weblink

**Product description**

**1 Product Model, 2 Installation Types**

The special advantage of IF models: Installation as flush with the adjacent areas as well as laid flat on top is possible.

**Flush-mounted installation: Recommendation for the choice of worktop:**

We recommend installation in worktops made of ceramic, granite, artificial stone (e.g. Corian or Varicor) or solid wood. We do not recommend installation in coated chipboard.

**Cleaning**

The Desino Drain Sieve is dishwasher-safe and can be cleaned completely or separately up to a maximum temperature of 65°C.

**Accessory**

Optional accessories



> Weblink  
40.000.912.00 / CHF  
106.-  
Colander, perforated



> Weblink  
40.001.289.00 / CHF  
106.-  
Colander, unperforated

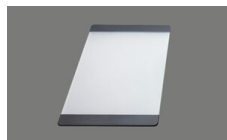

> Weblink  
40.000.909.00 / CHF  
151.-  
Chopping board, made of  
glass, white



> Weblink  
40.001.277.00 / CHF  
151.-  
Chopping board, made of  
plastic

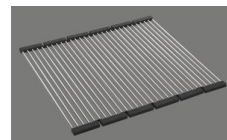

> Weblink  
40.001.138.00 / CHF  
125.-  
Inox Pad

**Daneo DAN 45IF/12** > [Web link](#)

**Spares**

You can find the compatible range of spares here > [Weblink](#)

# Daneo DAN 45IF/12 Desino

**Randbreite 12mm**  
**Bord de 12mm de largeur**  
**Larghezza bordo 12mm**

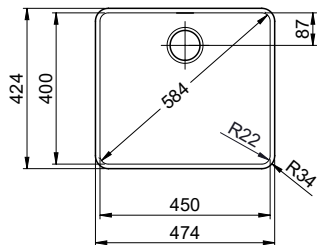

Für 12mm Arbeitsplatte.  
 Pour plan de travail de 12mm.  
 Per piano di lavoro da 12mm.

X (1 : 2)



Y (1 : 2)



Silikonieren  
 Appliquer du silicone  
 Applicare il silicone

Traverse  
 Transversale  
 Traversa

Für 13 - 30mm Arbeitsplatte.  
 Pour plan de travail de 13 - 30mm.  
 Per piano di lavoro da 13 - 30mm.

X (1 : 2)

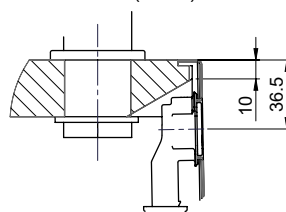

Y (1 : 2)

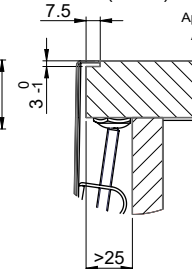

Silikonieren  
 Appliquer du silicone  
 Applicare il silicone

Traverse  
 Transversale  
 Traversa

Für 13 - 50mm Arbeitsplatte.  
 Pour plan de travail de 13 - 50mm.  
 Per piano di lavoro da 13 - 50mm.

X (1 : 2)

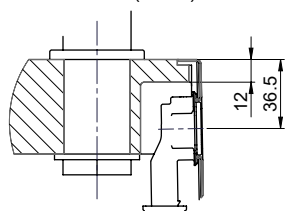

Y (1 : 2)



Silikonieren  
 Appliquer du silicone  
 Applicare il silicone

Traverse  
 Transversale  
 Traversa

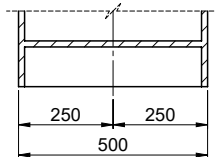
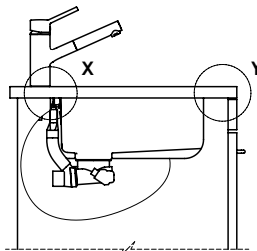
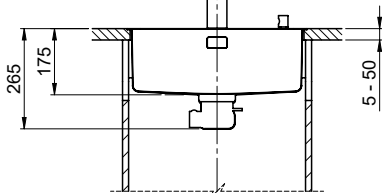

Bei der Planung die Traverse im Möbel beachten!

Faites attention à la barre transversale dans les meubles lors de la planification!

Presta attenzione alla traversa nei mobili durante la pianificazione!

Vom flächenbündigen Einbau in beschichteten Spanplatten raten wir ab.

Nous vous déconseillons le montage à fleur sur des panneaux de particules enduits.

Sconsigliamo il montaggio a filo top in pannelli di truciolato laminato.

Bohrung für Zug- und Druckknöpfe ø14  
 Bohrung für Drehknopf ø25

Trou pour boutons et Pousoirs de commande ø14  
 Trou pour bouton rotatif ø25

Foro per Pomelli tiranti e Pomelli pulsanti ø14  
 Foro per Pomolo girevoli ø25

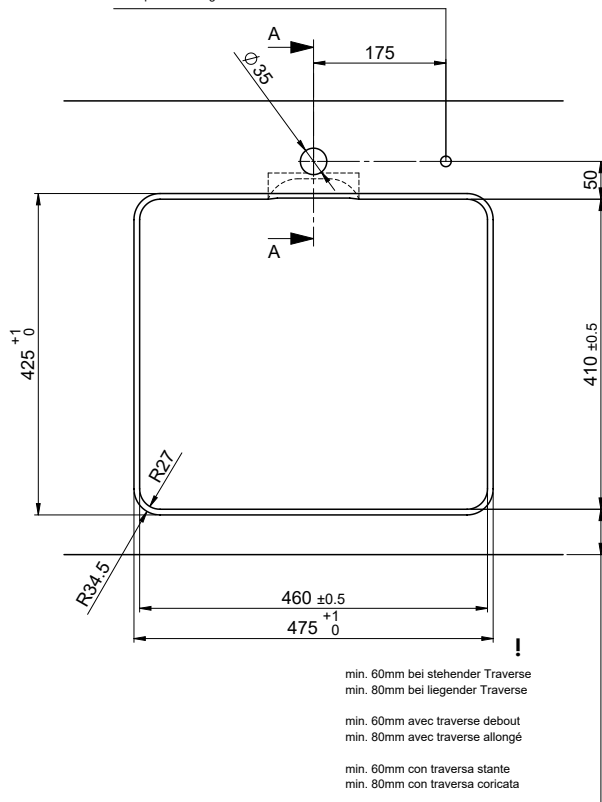

Für 12mm Arbeitsplatte.  
 Pour plan de travail de 12 mm.  
 Per piano di lavoro da 12 mm.

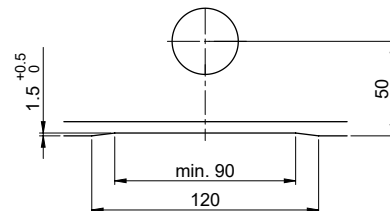

A-A (1 : 2)

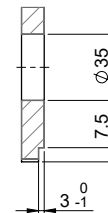

Für 13 - 30mm Arbeitsplatte.  
 Pour plan de travail de 13 - 30mm.  
 Per piano di lavoro da 13 - 30mm.

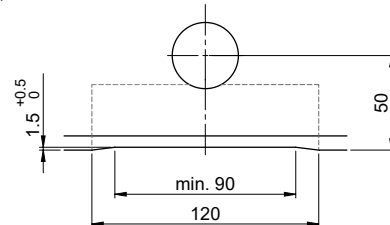

A-A (1 : 2)

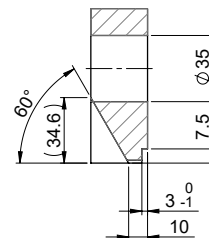

Für 13 - 50mm Arbeitsplatte.  
 Pour plan de travail de 13 - 50mm.  
 Per piano di lavoro da 13 - 50mm.

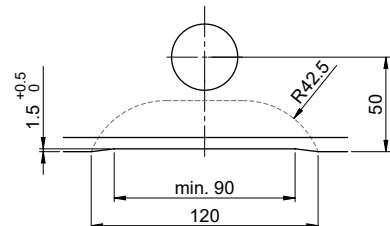

A-A (1 : 2)

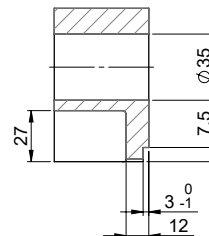

# Daneo DAN 45IF/12 Desino

Ausschnitt für flach aufliegender Einbau - Randbreite 12mm:  
 Mesure de coupure pour montage en appui - Bord de 12mm de largeur:  
 Intaglio per montaggio soprapiano - Larghezza bordo 12mm:

Bohrung für Zug- und Druckknöpfe ø14  
 Bohrung für Drehknopf ø25

Trou pour boutons et Pousoirs de commande ø14  
 Trou pour bouton rotatif ø25

Foro per Pomelli tiranti e Pomelli pulsanti ø14  
 Foro per Pomolo girevoli ø25

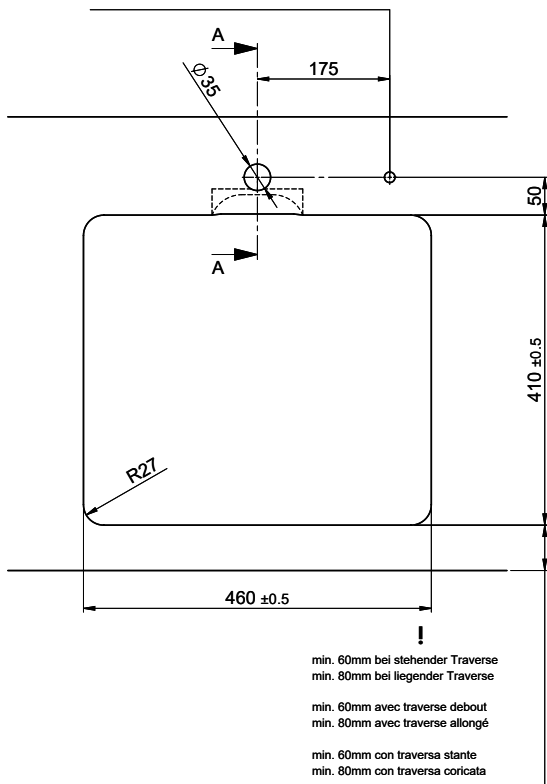

Für 12mm Arbeitsplatte.  
 Pour plan de travail de 12 mm.  
 Per piano di lavoro da 12 mm.



A-A (1 : 2)



Für 13 - 30mm Arbeitsplatte.  
 Pour plan de travail de 13 - 30mm.  
 Per piano di lavoro da 13 - 30mm.



A-A (1 : 2)

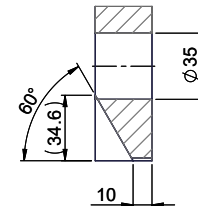

Für 13 - 50mm Arbeitsplatte.  
 Pour plan de travail de 13 - 50mm.  
 Per piano di lavoro da 13 - 50mm.

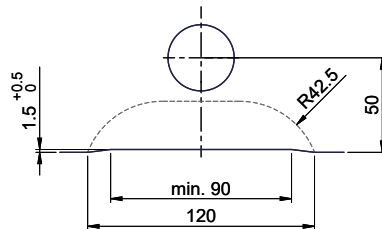

A-A (1 : 2)

