

Samsung Samsung Compact Oven with Microwave BM30/50

[> Web link](#)

Model
Samsung Samsung Compact Oven with Microwave
BM30/50

Manufacturer ID
NQ50J3530BS/EO

Article no.
500.000.006.00

Appliance type
Compact unit

Construction
Euro Norm 60 cm

VRG
10.00

Price CHF
520.- excl. VAT

Highlights

- Steam cleaning
- 25 automatic programs
- 50 L cooking capacity - exceptionally spacious
- Compact: combined microwave and oven
- Cooking chamber with ceramic enamel: scratch-proof, anti-bacterial
- Easy to operate: retractable knob and sensor buttons

Product description

Construction: **Euro-Norm 60 cm**
GTIN-Nr.: **8806086705400**

Efficiency and consumption

Energy efficiency class (from A+++ to D): -

Energy efficiency index: -

Energy consumption

Energy consumption, conventional (kWh / cycle): -

Energy consumption, convection / hot air (kWh / cycle): -

Standby consumption: **0,5 W**

Consumption pyrolytic cleaning process (kWh / cycle): -

Design

Color control panel: **Silver**

Material control panel: **Stainless Steel**

Frame / material: **Yes / stainless steel**

Display and operation

Display: **Digital display**

Display and lighting: **LED, ice blue**

Operation: **Retractable knob, sensor buttons**

Interconnection of household appliances

Samsung Smart Home: -

Performance properties

max. adjustable temperature for top / bottom heat, convection / hot air: **230°C**

Temperature for steam operation: -

Microwave power output: **1650 W**-

Useable grilling space: **2970 cm²**

Useable oven capacity: **50 L**

Dimensions

Height: **45.4 cm**

Width: **59.5 cm**

Depth: **54.9 cm**

Depth (from front of unit): **57 cm**

Depth with open door (in front of unit): -

Unit dimensions (H x W x D) : **454 x 595 x 549 mm**

Empty weight

Unit weight: **38.3 kg**

Fittings

Inside dimensions (useable size) mm (height / width / depth): **247 x 443 x 443 mm**

Top and bottom heat: **Yes**

Convection: **Yes**

Hot air: **Yes**

Steam:

Samsung Samsung Compact Oven with Microwave BM30/50

[> Web link](#)

-
 Microwave: **Yes**
 Catalytic cleaning aid : **Yes**
 Pyrolytic cleaning aid : -
 Grill heating element available / retrofittable: **Yes / -**
 Grill motor / convection grilling: -
 Timer switch / timer: **Yes**
 Drawer / warming drawer: - / **optional**
 Number of cooking chambers: **1**
 Volume per cooking chamber
 Single-chamber operation / top cooking chamber / bottom cooking chamber: **50 L / - / -**
 Number of shelf levels: **5**
 Lighting / inspection window: **Yes / Yes**
 Lighting : **1 x 40 W, halogen**
 Telescope rails: -
 Cleaning: **Catalysis, steam cleaning**
 Cooling process: **Cooling ventilator**
 Interior lining: **Ceramic enamel**

Operating modes

Steam: -
 Steam + heating: -
 Steam + hot air: -
 Steam + top heat + hot air:-
 Steam + bottom heat + hot air: -
 Top / bottom heat: -
 Hot air: **40-230°C**
 Hot air ECO: -
 Grill: large / eco / convection: **150-200°C / 150-230°C**
 Bottom heat + hot air: -
 Top heat + hot air: -
 Bottom heat : -
 Fast cooking: -
 Automatic roasting (ProRoasting) : -
 Microwave + grill: **40-200°C**
 Microwave + hot air: **40-200°C**

Programs

Special functions: -
 Automatic programs: **25**
 Dual Cook: -

Control functions

Control functions: **Time, child safety, kitchen timer, oven temperature, end time, signal tone**

Capacity

Total capacity: **3000 W**
 Hot air : **2500 W**
 Top heat : **1400 / 1100 W**
 Bottom heat : **1000 W**
 Grill max. / min.: **2500 W**
 Large-sized grill: -
 Steam:-
 Microwave: **1650 W**

Electrical connection

Supply voltage g: **230 V**
 Frequency : **50 Hz**
 Connection values: **3.0 kWh**
 Fuse protection: **16 A**
 Length power connection: **2 m**
 Power plug: **Schuko safety plug with CH adapter (16 A, type 23)**

Technical data

Standard width: **Euro-Norm 60 cm**
 Standard height: **Euro-Norm 45 cm**
 Niche height: **446 mm - 450 mm**
 Niche width: **564 mm - 568 mm**
 Niche depth: **min. 550 mm**
 Niche dimensions (H x W x D): **min. 446-450 x 564-568 x 550 mm**
 Unit width in mm : **595 mm**
 Unit height in mm: **454 mm**
 Unit depth in mm: **549 mm**

Packaging

Weight, incl. packaging: **45.6 kg**
 Packaging dimensions (H x W x D):

Samsung Samsung Compact Oven with Microwave BM30/50 > Web link

578 x 700 x 663 mm

Accessory

Included accessories



> Weblink
500.000.041.00 / CHF
520.-
Ceramic insert

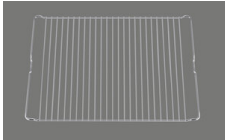

> Weblink
500.000.043.00 / CHF
520.-
Grill grid

Optional accessories



> Weblink
500.000.074.00 / CHF
60.-
Set of support brackets

Compatible Articles



> Weblink
500.000.009.00 / CHF
350.-
Drawer WS10/20/30/50



> Weblink
500.000.006.00 / CHF
520.-
Samsung Compact Oven
with Microwave BM30/50

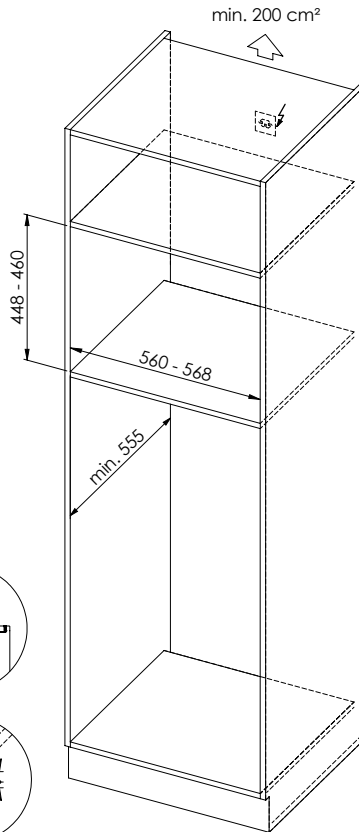
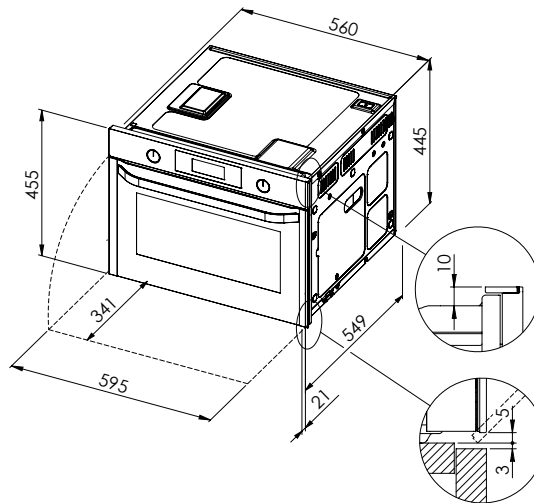
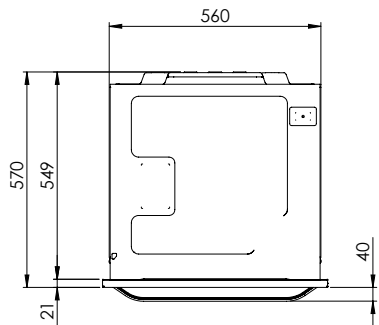
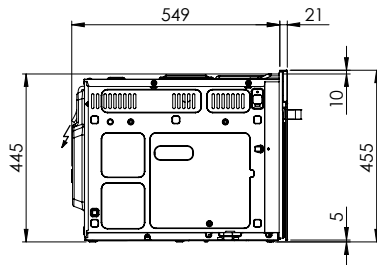
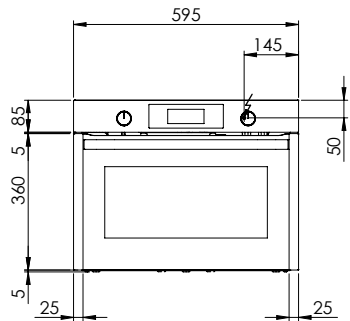

BM30/50: 230 V / 16 A, T23, 2000 mm

Für diese Zeichnung sind die folgenden Spezialitäten Gegenstand der Rechte von Suter Inox AG. Weiteres Kopieren, Reproduzieren, Verbreiten oder Verwenden dieser Zeichnung ist ohne unsere Zustimmung untersagt. © Copyright 2003 Suter Inox AG. All rights reserved.

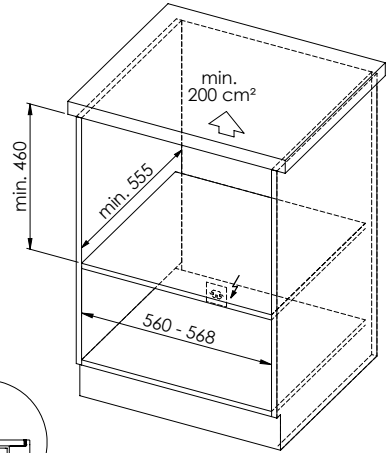
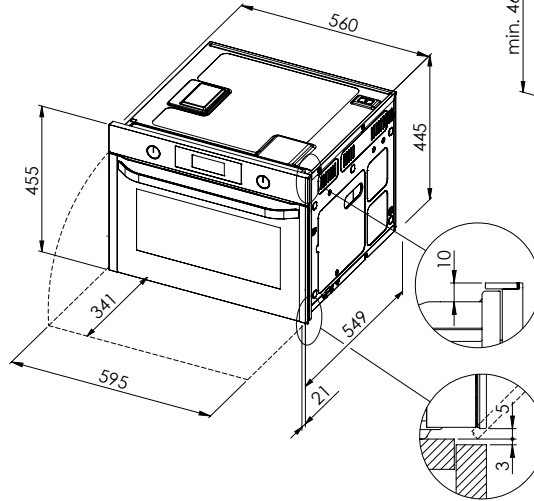
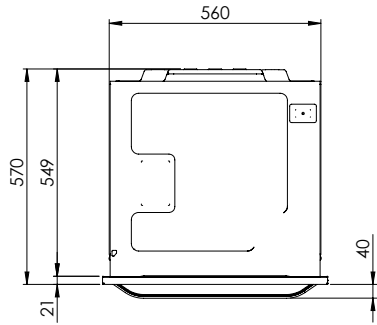
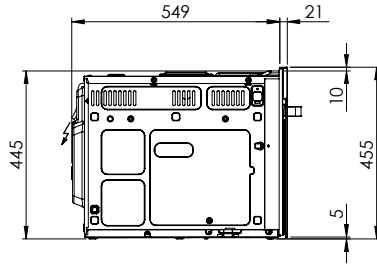
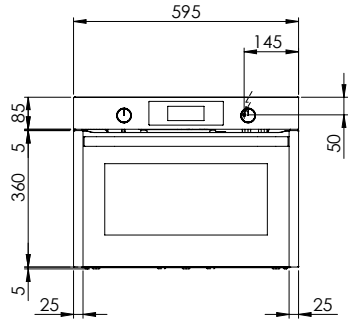

BM30/50: 230 V / 16 A, T23, 2000 mm

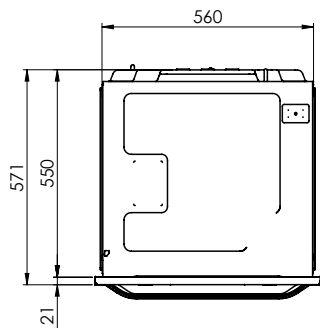
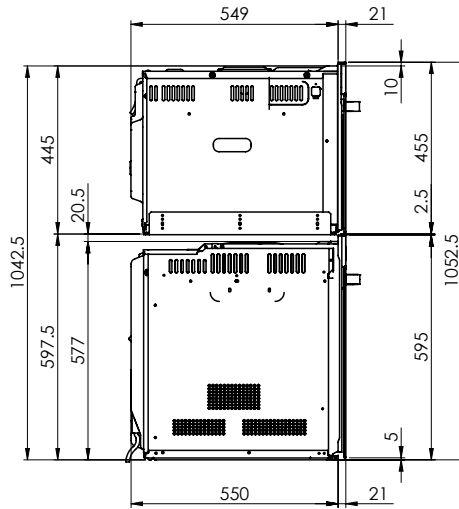
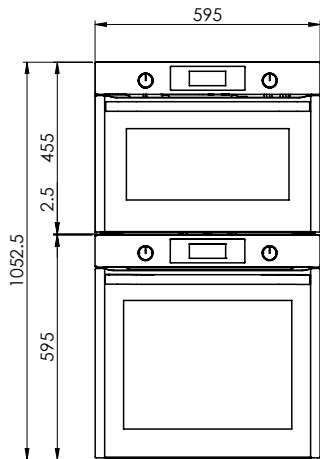

Bei Mehrgerätemontage übereinander: Berücksichtigen Sie bei der Planung der Elektroanschlüsse die jeweiligen Gerätespezifikationen.
 Montage de plusieurs appareils l'un sur l'autre: veuillez tenir compte des spécifications de chaque appareil lors de la planification des raccordements électriques.
 Montaggio in colonna di più apparecchi: nella pianificazione degli allacciamenti elettrici, attenersi alle specifiche dei rispettivi apparecchi.

Es ist das Nachwendrecht vorbehalten, dieses Diagramm, Gegenstandsbezeichnungen und alle Rechte vor, Nach und Nebenrecht, Marken, Patente, Copyrights oder Verwendungen dieses Zeichens ohne unsere Zustimmung ist verboten. © Copyright 2003 Suter Inox AG. All rights reserved.

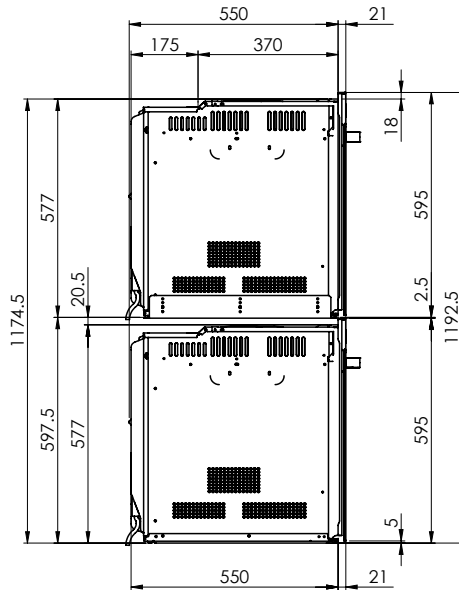
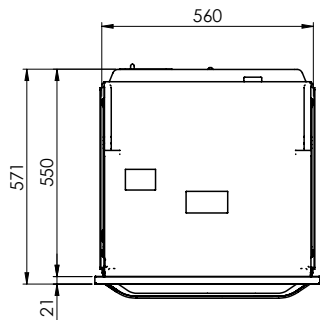
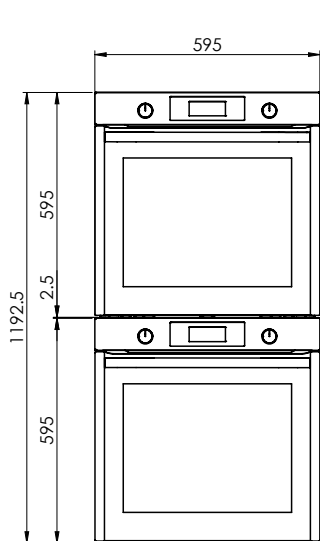

Bei Mehrgerätemontage übereinander: Berücksichtigen Sie bei der Planung der Elektroanschlüsse die jeweiligen Gerätespezifikationen.
 Montage de plusieurs appareils l'un sur l'autre: veuillez tenir compte des spécifications de chaque appareil lors de la planification des raccordements électriques.
 Montaggio in colonna di più apparecchi: nella pianificazione degli allacciamenti elettrici, attenersi alle specifiche dei rispettivi apparecchi.

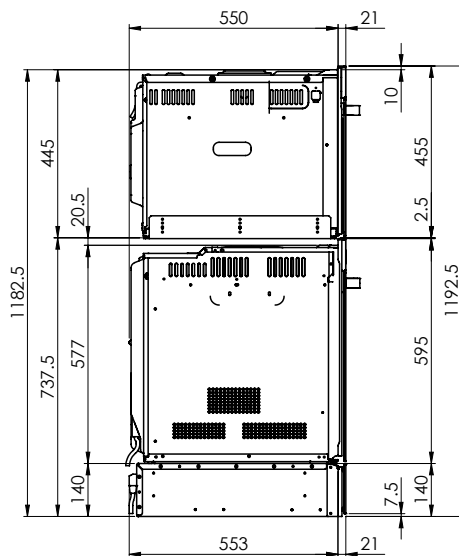
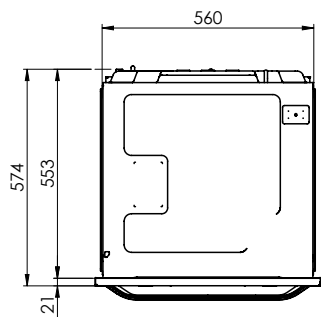
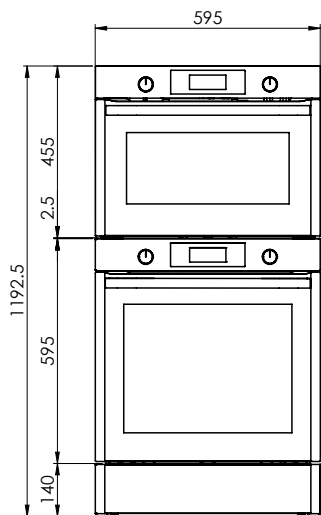

Bei Mehrgerätemontage übereinander: Berücksichtigen Sie bei der Planung der Elektroanschlüsse die jeweiligen Gerätespezifikationen.
 Montage de plusieurs appareils l'un sur l'autre: veuillez tenir compte des spécifications de chaque appareil lors de la planification des raccordements électriques.
 Montaggio in colonna di più apparecchi: nella pianificazione degli allacciamenti elettrici, attenersi alle specifiche dei rispettivi apparecchi.

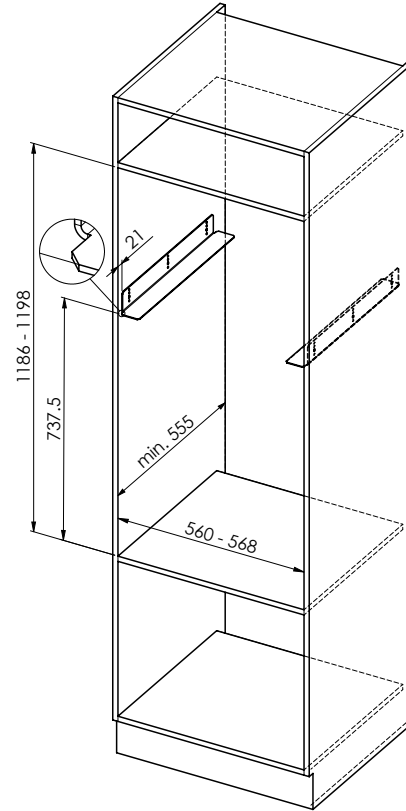
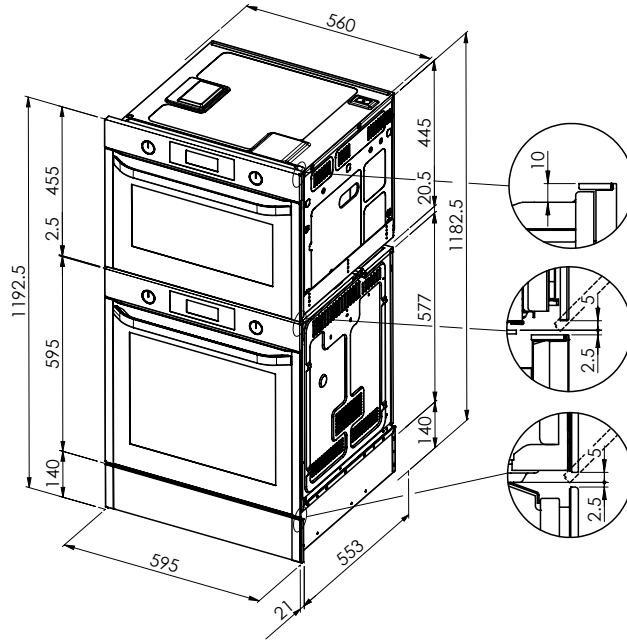

Bei Mehrgerätemontage übereinander: Berücksichtigen Sie bei der Planung der Elektroanschlüsse die jeweiligen Gerätespezifikationen.
 Montage de plusieurs appareils l'un sur l'autre: veuillez tenir compte des spécifications de chaque appareil lors de la planification des raccordements électriques.
 Montaggio in colonna di più apparecchi: nella pianificazione degli allacciamenti elettrici, attenersi alle specifiche dei rispettivi apparecchi.

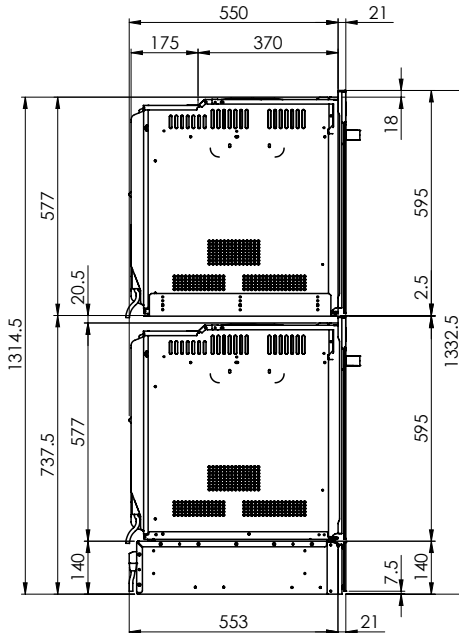
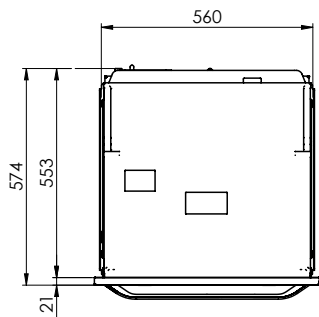
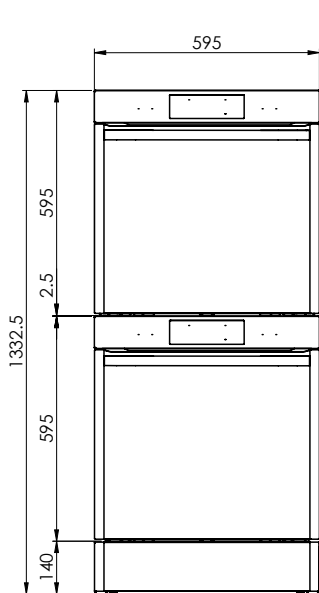

Bei Mehrgerätemontage übereinander: Berücksichtigen Sie bei der Planung der Elektroanschlüsse die jeweiligen Gerätespezifikationen.
 Montage de plusieurs appareils l'un sur l'autre: veuillez tenir compte des spécifications de chaque appareil lors de la planification des raccordements électriques.
 Montaggio in colonna di più apparecchi: nella pianificazione degli allacciamenti elettrici, attenersi alle specifiche dei rispettivi apparecchi.

