

Set WM120 (lft)+ TR120 (rt)+ SKK-UDW: Offer of washer/dryer tower set[> Web link](#)**Model**

Samsung Washing machine WM120
 Samsung Dryer TR120 (right)
 Combination set SKK-UDW washer/dryer tower with pull-out WM120

Energy efficiency class

A (New Label 03.21)
 C

Article no.

500.000.133.00

Appliance type / construction type

Washer/dryer tower

Door hinge

Left
 Right

VRG

36.00

Price CHF

2'736.- excl. VAT

Highlights

- For a detailed description of the washing machine and dryer supplied in this set, please refer to the separate product pages of these two appliances.

Product description**Set offer «WM120 + TR120»**

Scope of delivery set offer:

- 1 washing machine WM120 (500.000.121): door hinge left (not changeable)
- 1 Dryer TR120 (500.000.127): door hinge right
- 1 Connection set with pull-out SKK-UDW (500.000.129)

Accessory**Included accessories**

[> Weblink](#)

500.000.129.00 / CHF 2.-
 Combination set
 SKK-UDW washer/dryer
 tower with pull-out
 WM120

Optional accessories

[> Weblink](#)

500.000.065.00 / CHF
 59.-
 Lint filter



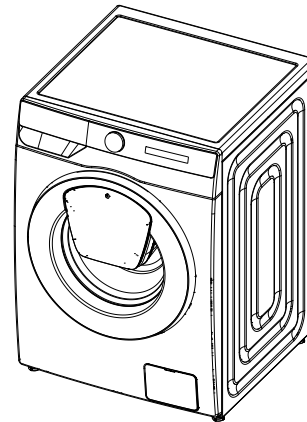
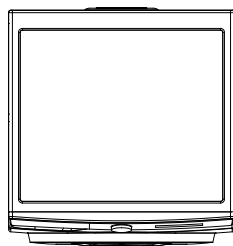
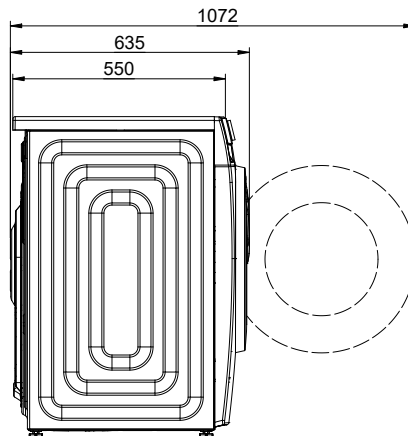
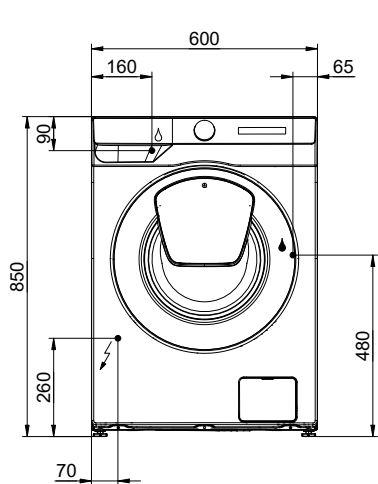

[> Weblink](#)

500.000.066.00 / CHF
 49.-
 Lint filter interior





 230V 10A T12 - L=2000mm

 Wasser Zulauf

 Wasser Ablauf

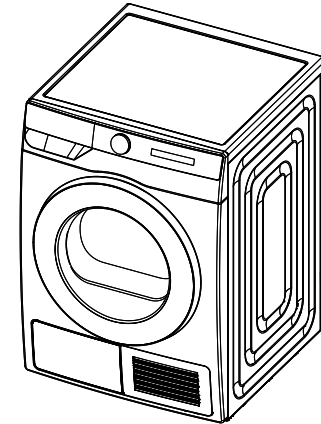
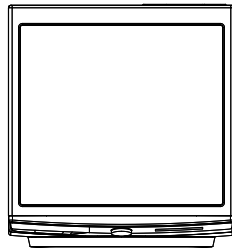
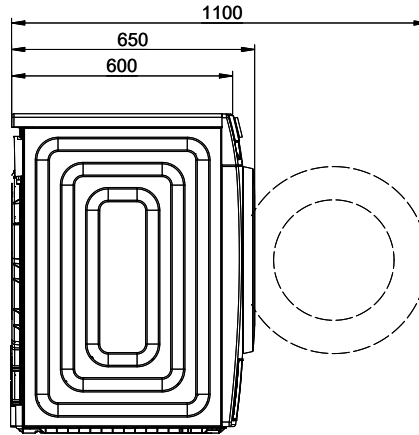
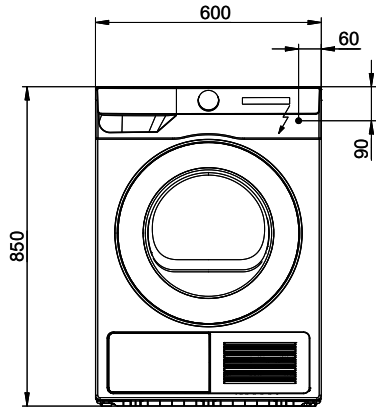
Technische Zeichnung für den privaten Gebrauch. Die Rechte an der Zeichnung sind vorbehalten. Copyright © Suter Technik AG, 2020.



 230V / 10A T12 L=1500mm