

Samsung BO110 - Gerätemasse

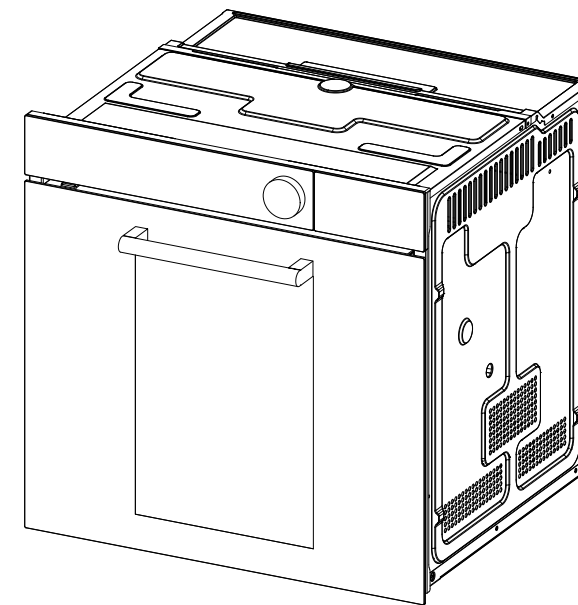
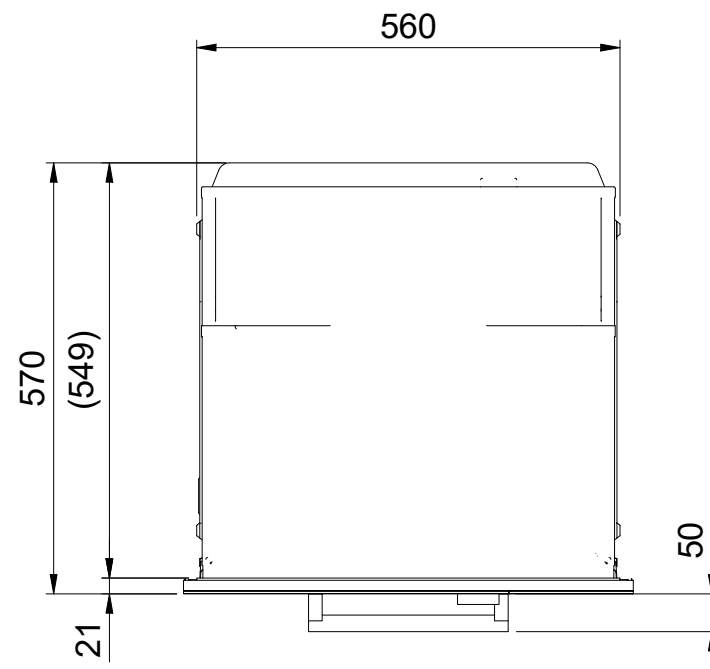
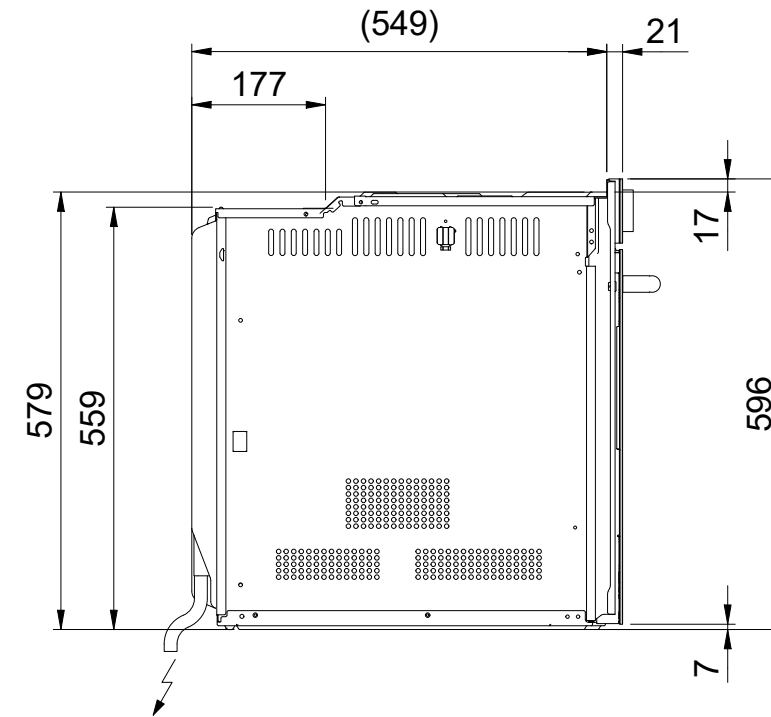
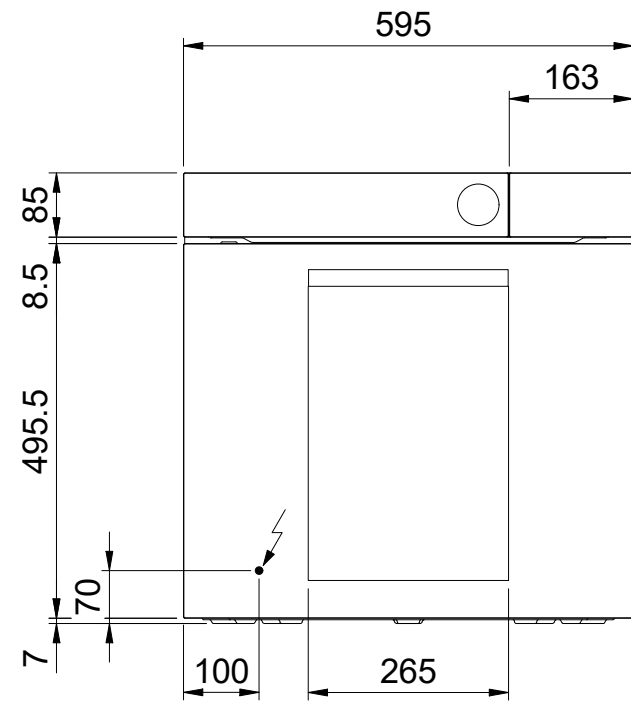

Für dieses Dokument und den darin dargestellten Gegenstand behalten wir uns alle Rechte vor. Vervielfältigung, Bekanntgabe an Dritte oder Verwendung ohne unsere schriftliche Zustimmung ist verboten. © Copyright 2005 Suter Inox AG. All rights reserved.

 BO110 / BO210: 230V / 16A, Direktanschluss / Direct wiring / Raccordement électrique / Rollegamento elettrico¹

¹ Anschlusskabel Bauseits
 Connecting wire on site
 Câble de raccordement fourni par le client
 Cavo di collegamento fornito da parte cliente

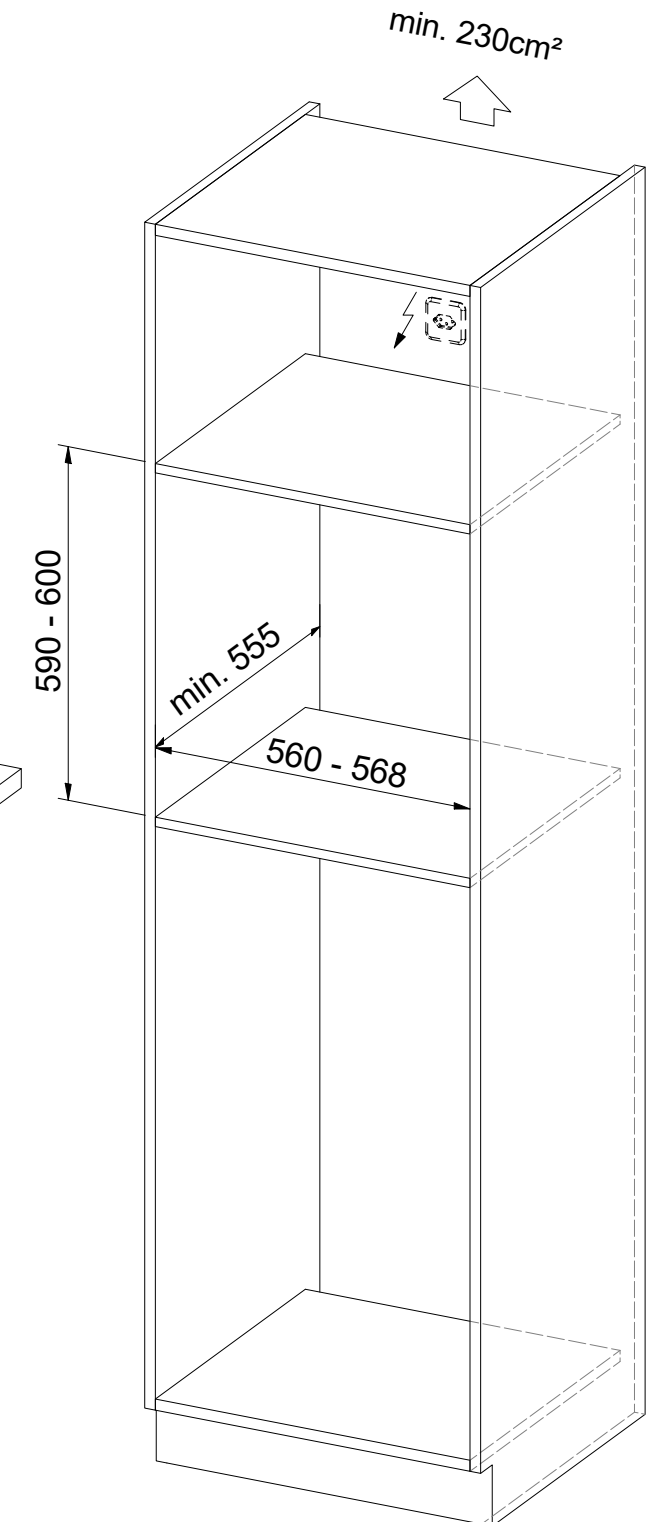
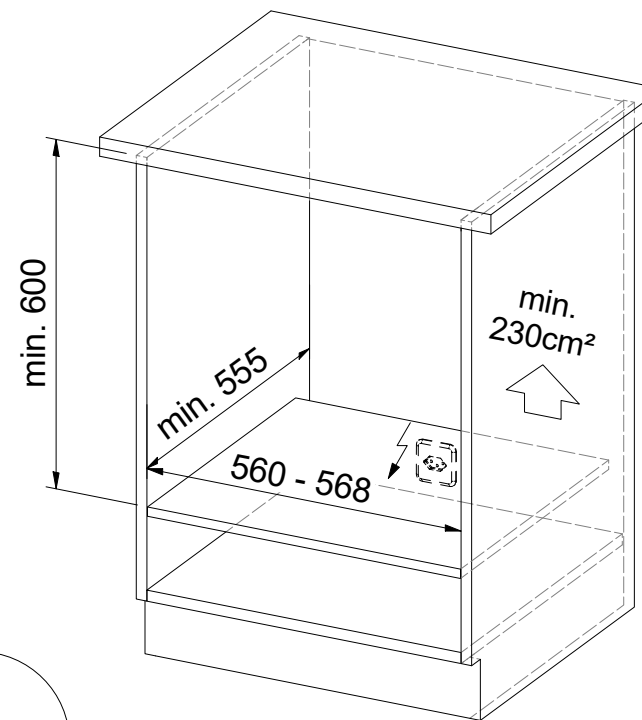
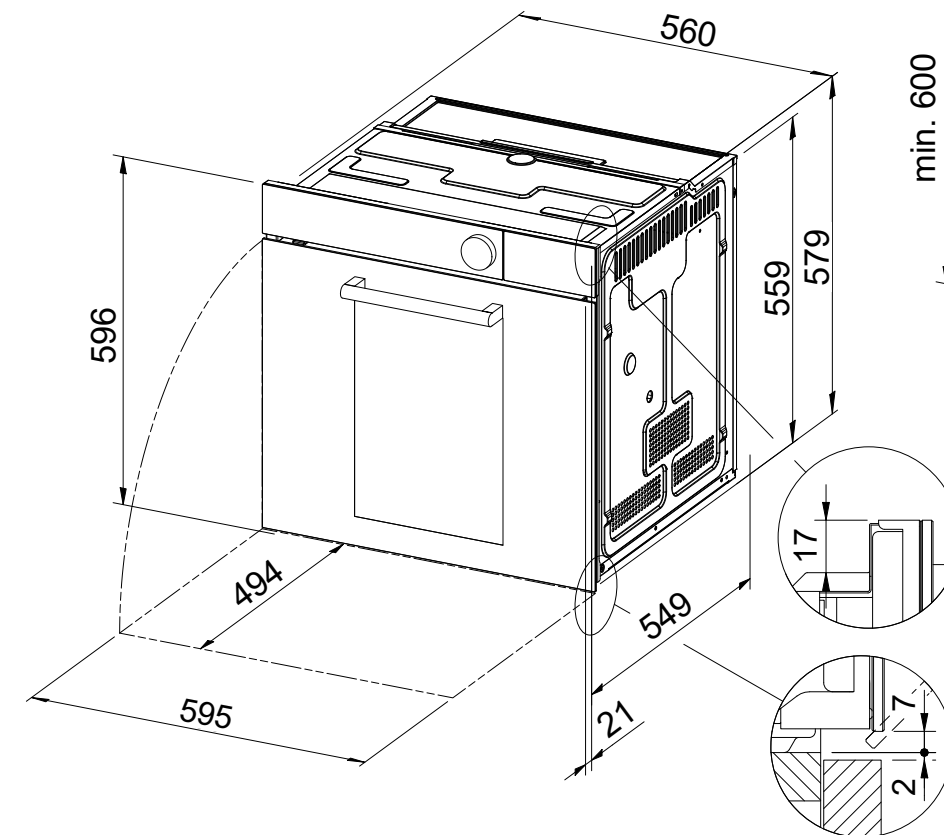
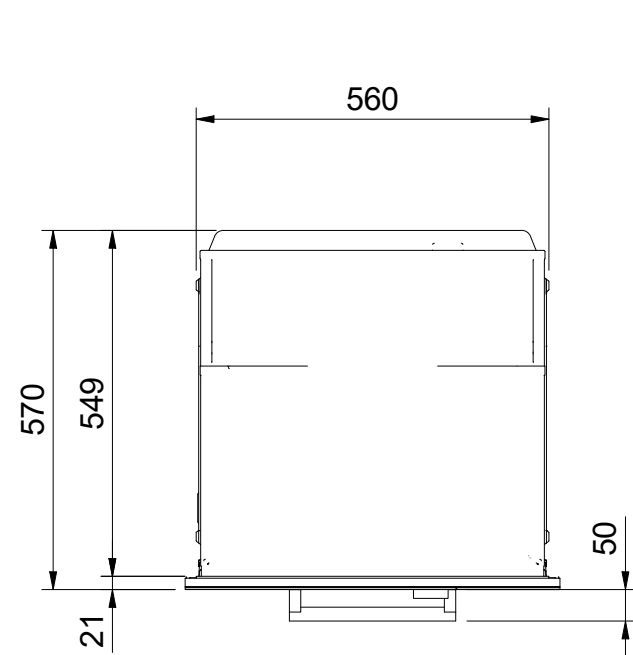
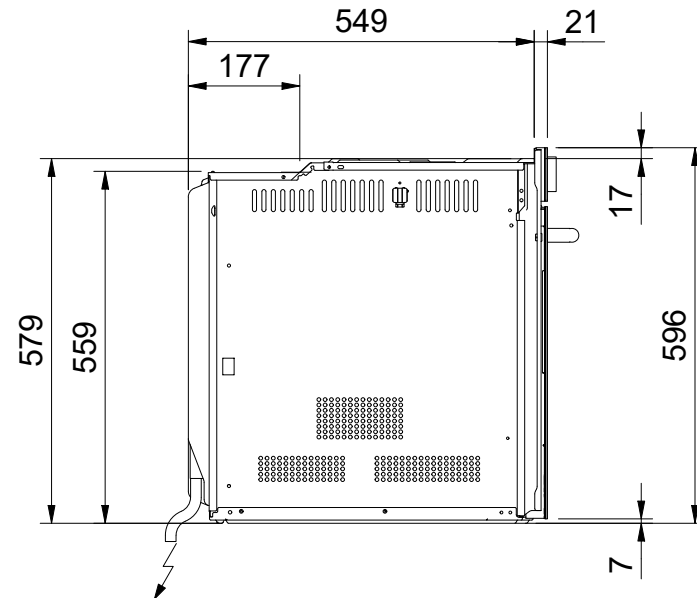
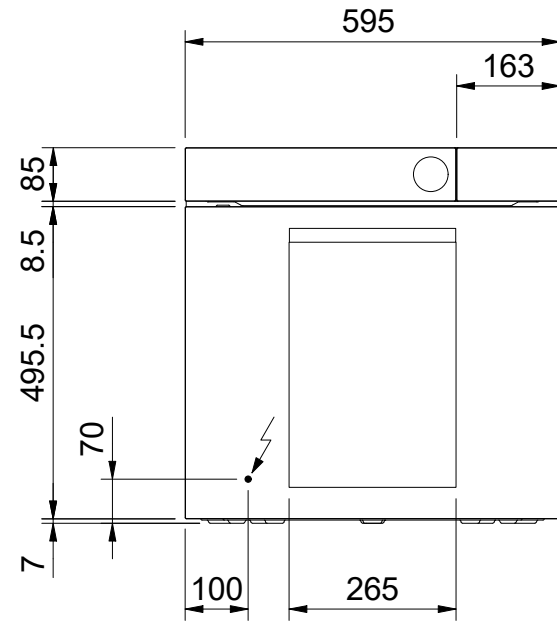

 BO110 / BO210 / BO120 / BO220: 230V / 16A, Direktanschluss / Direct wiring / Raccordement électrique / Rollegamento elettrico¹

 WS100 / WS200: 230V / 10A, T12, 1500mm

¹ Anschlusskabel Bauseits
 Connecting wire on site
 Câble de raccordement fourni par le client
 Cavo di collegamento fornito da parte cliente

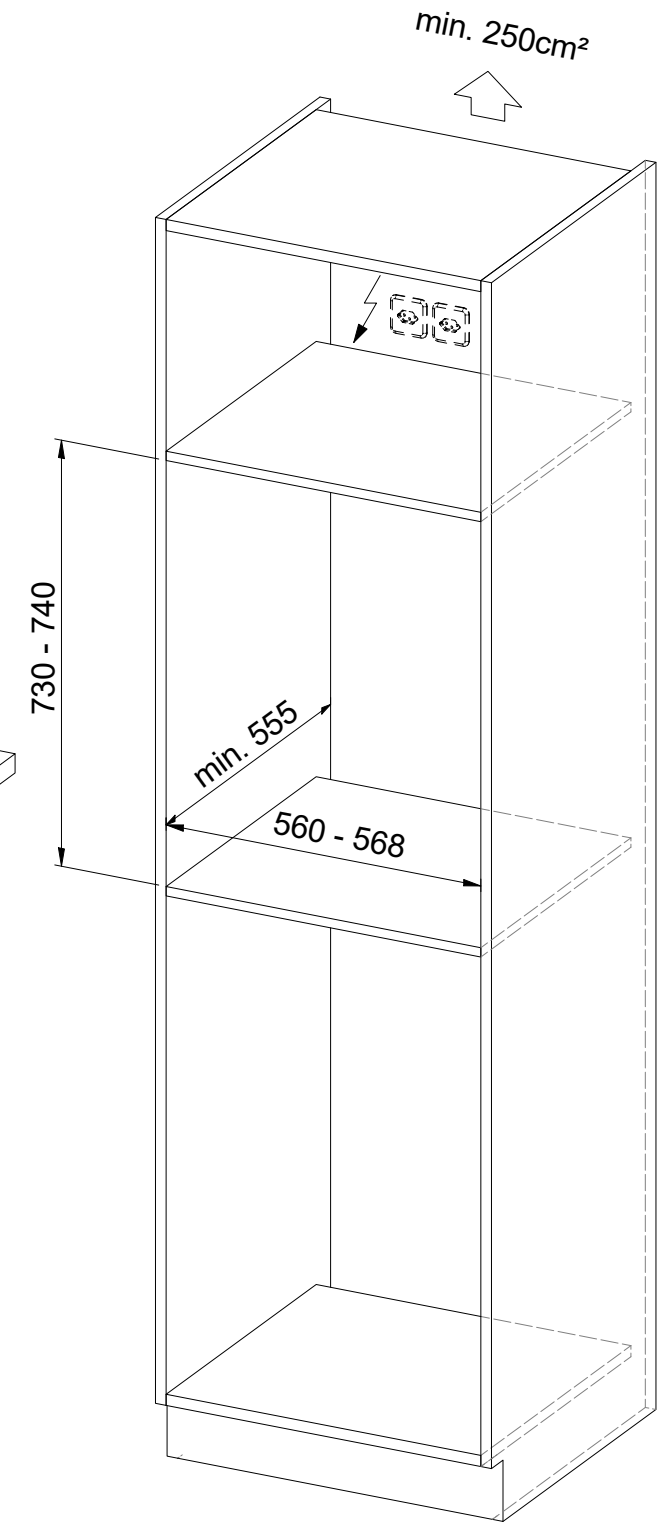
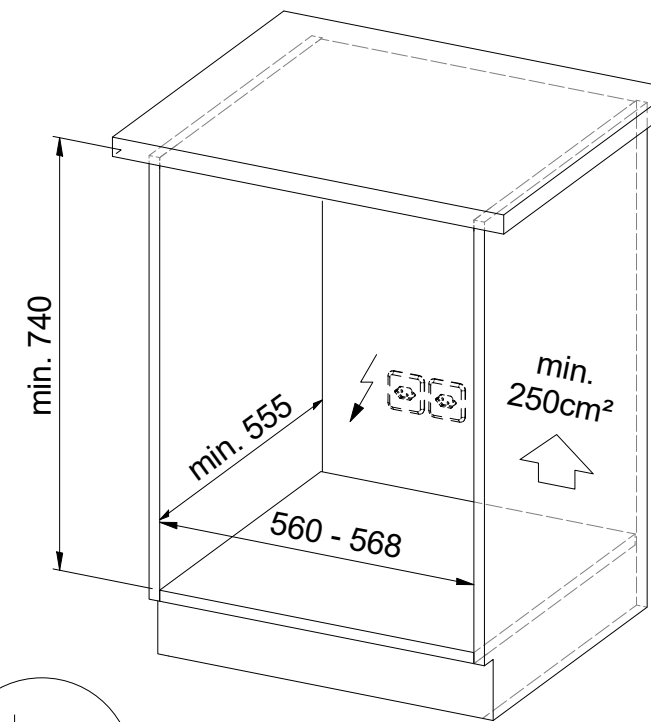
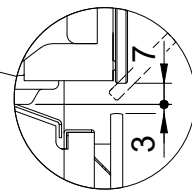
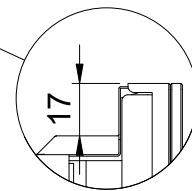
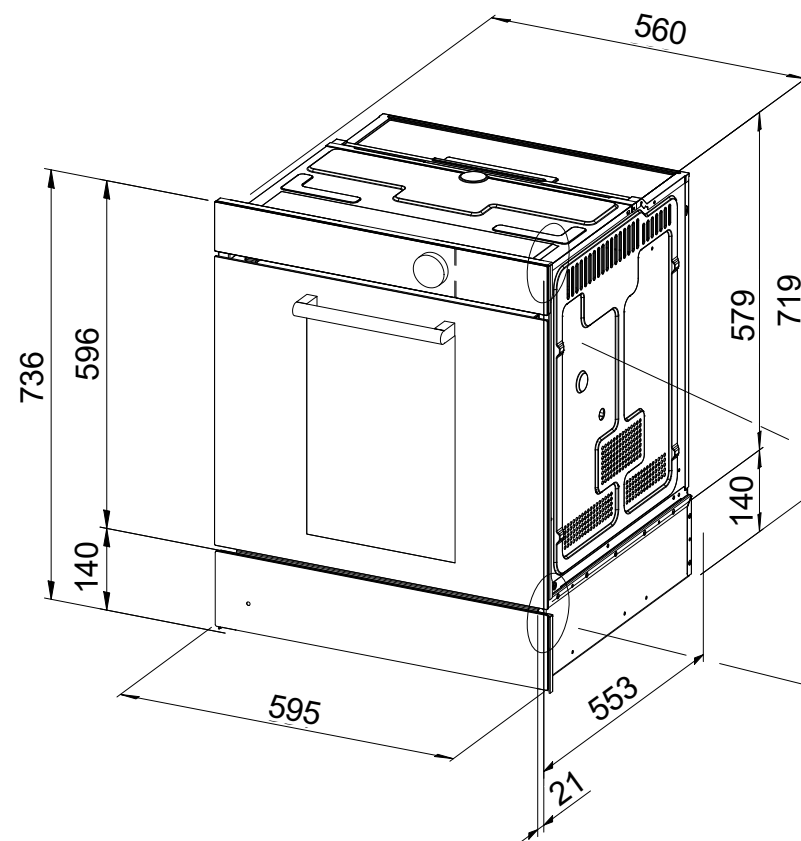
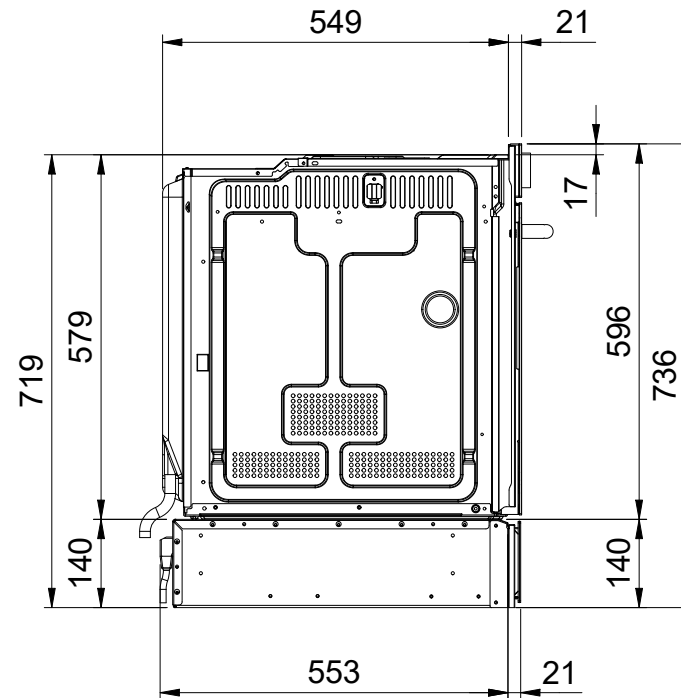
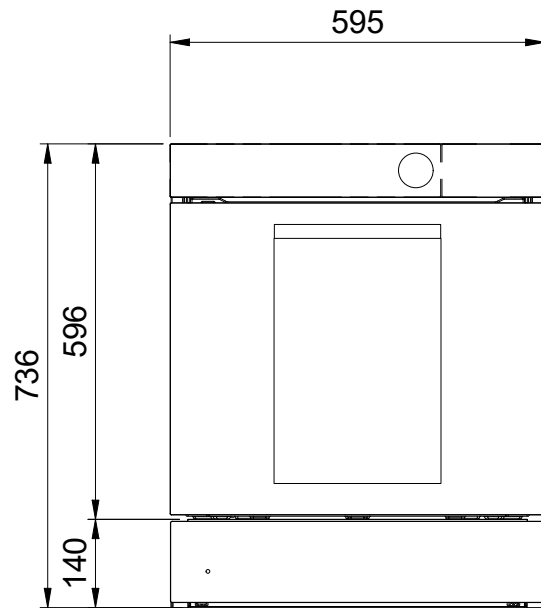

BO110 / BO210 / BO120 / BO220:

230V / 16A, Direktanschluss / Direct wiring / Raccordement électrique / Rollegamento elettrico¹

CS100 / CS200:

230V / 16A, Direktanschluss / Direct wiring / Raccordement électrique / Rollegamento elettrico, 1400mm

¹ Anschlusskabel Bauseits
 Connecting wire on site
 Câble de raccordement fourni par le client
 Cavo di collegamento fornito da parte cliente

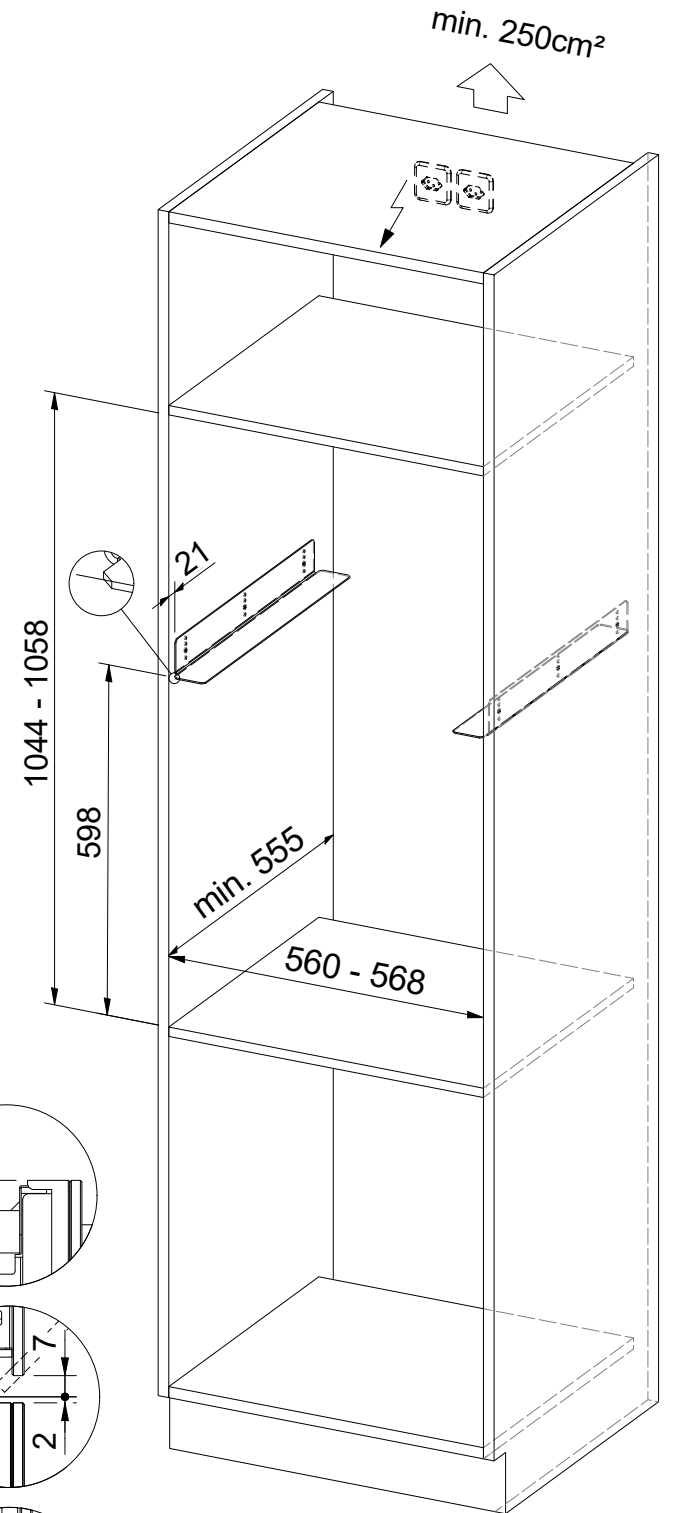
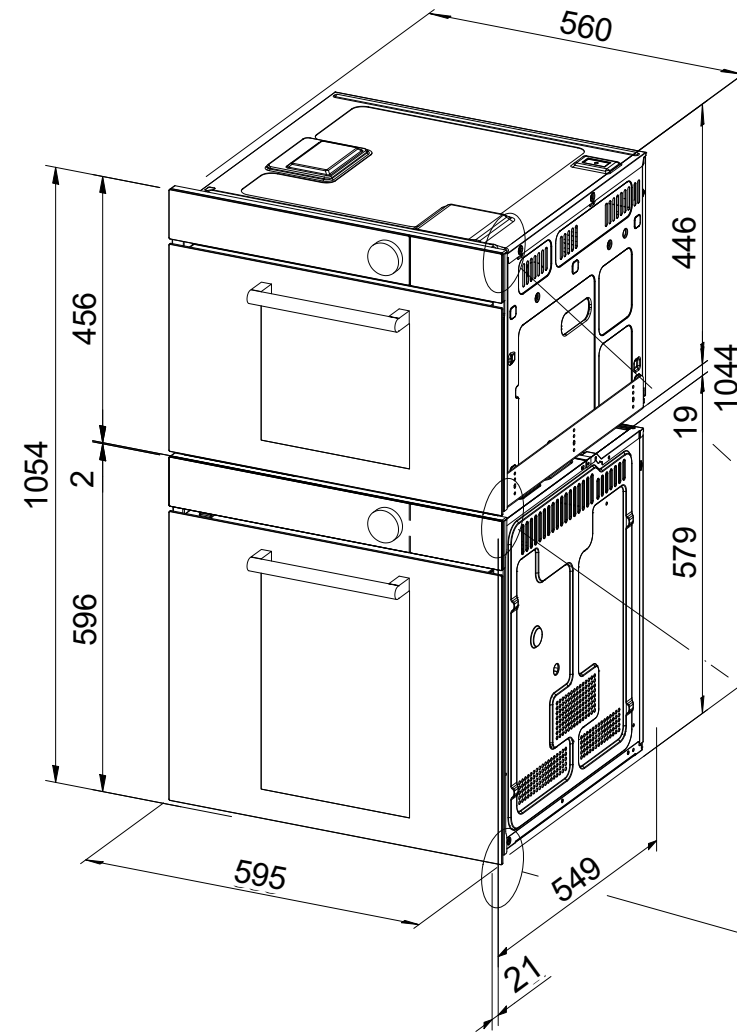
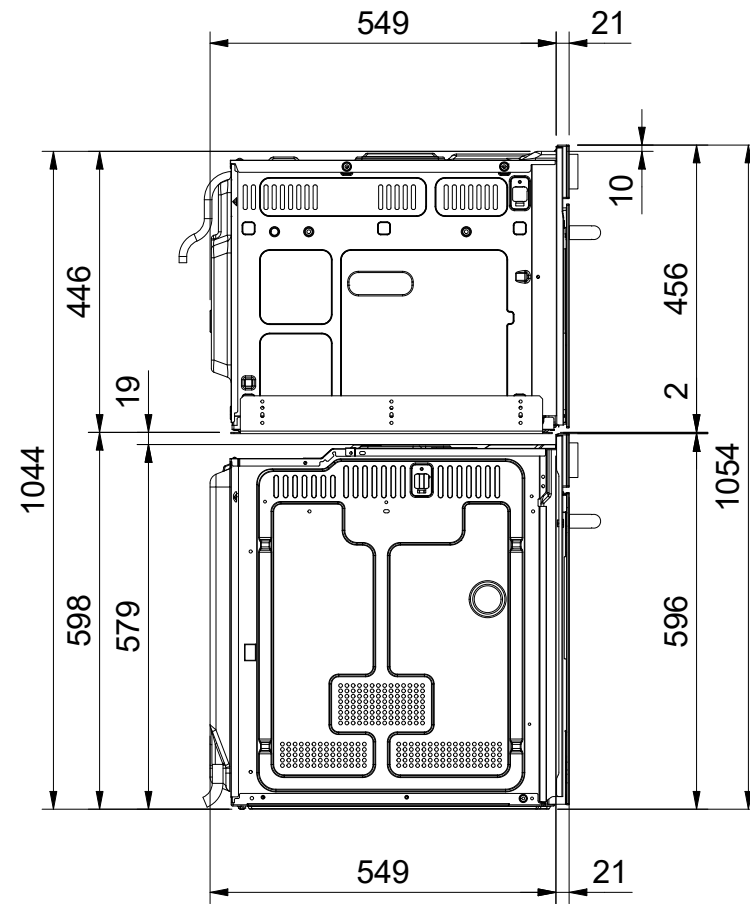
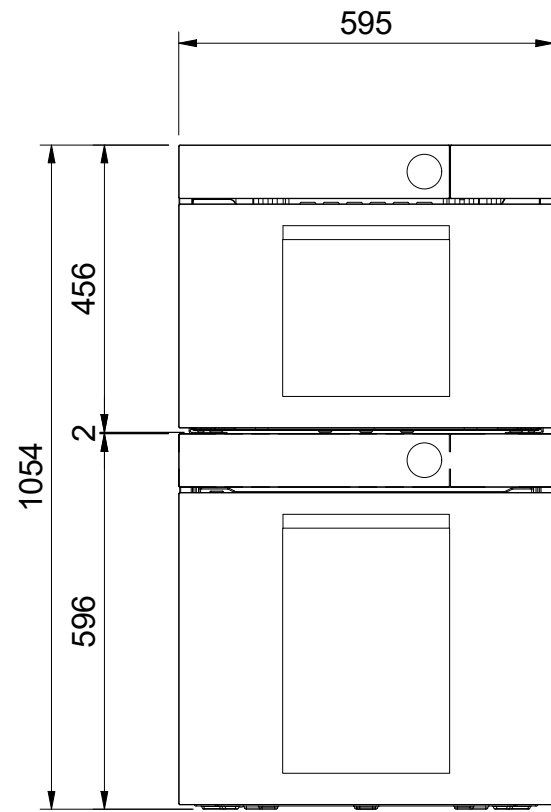

Bei Mehrgerätemontage übereinander: Berücksichtigen Sie bei der Planung der Elektroanschlüsse die jeweiligen Gerätespezifikationen.
 Montage de plusieurs appareils l'un sur l'autre: veuillez tenir compte des spécifications de chaque appareil lors de la planification des raccordements électriques.
 Montaggio in colonna di più apparecchi: nella pianificazione degli allacciamenti elettrici, attenersi alle specifiche dei rispettivi apparecchi.

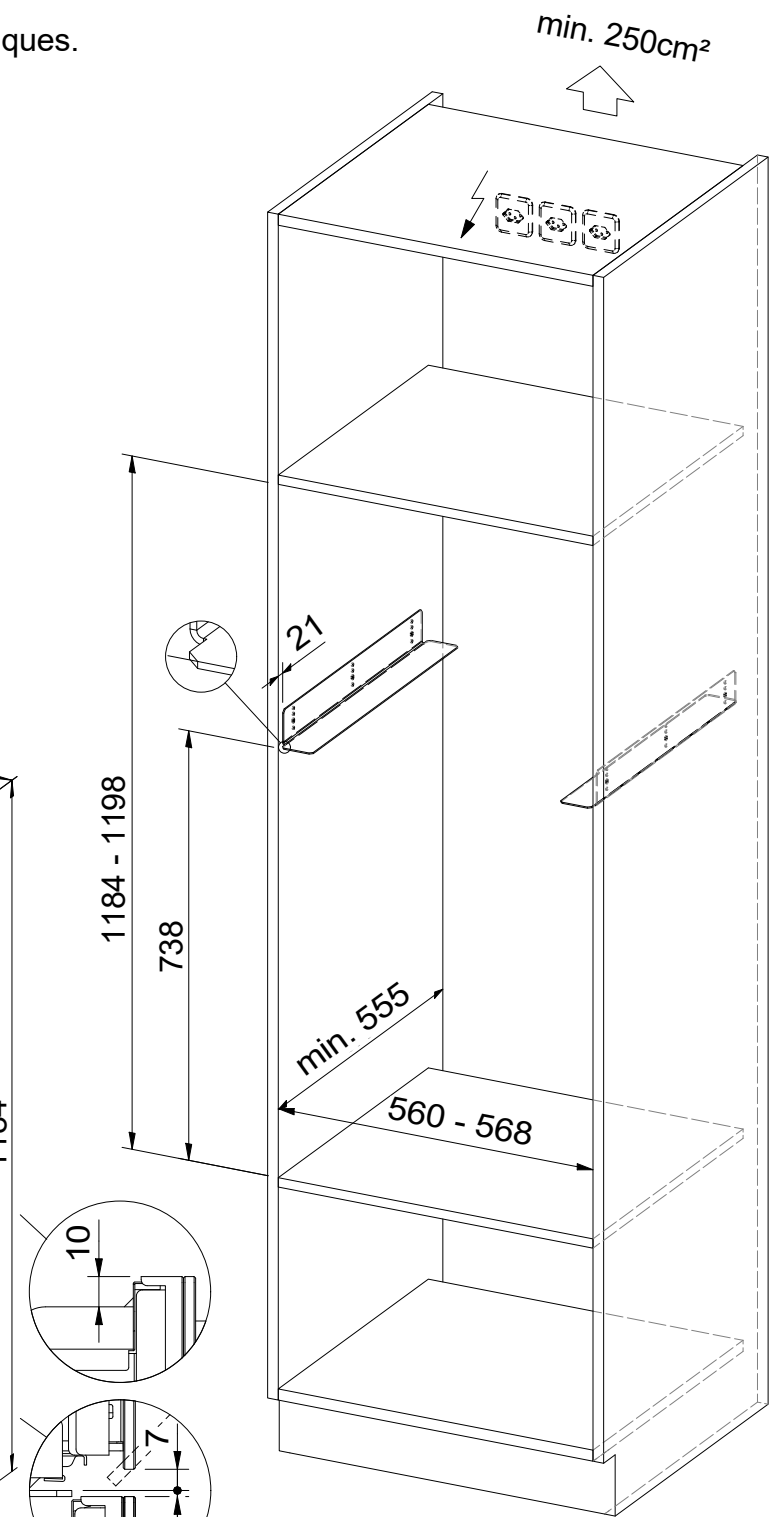
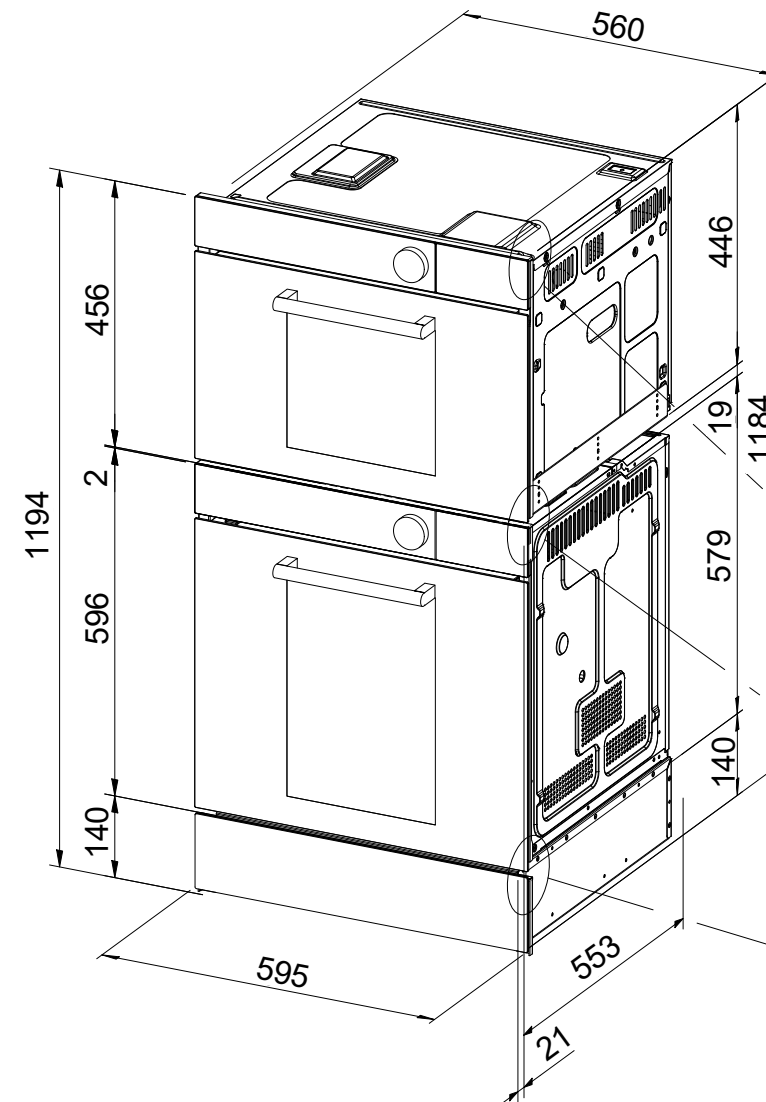
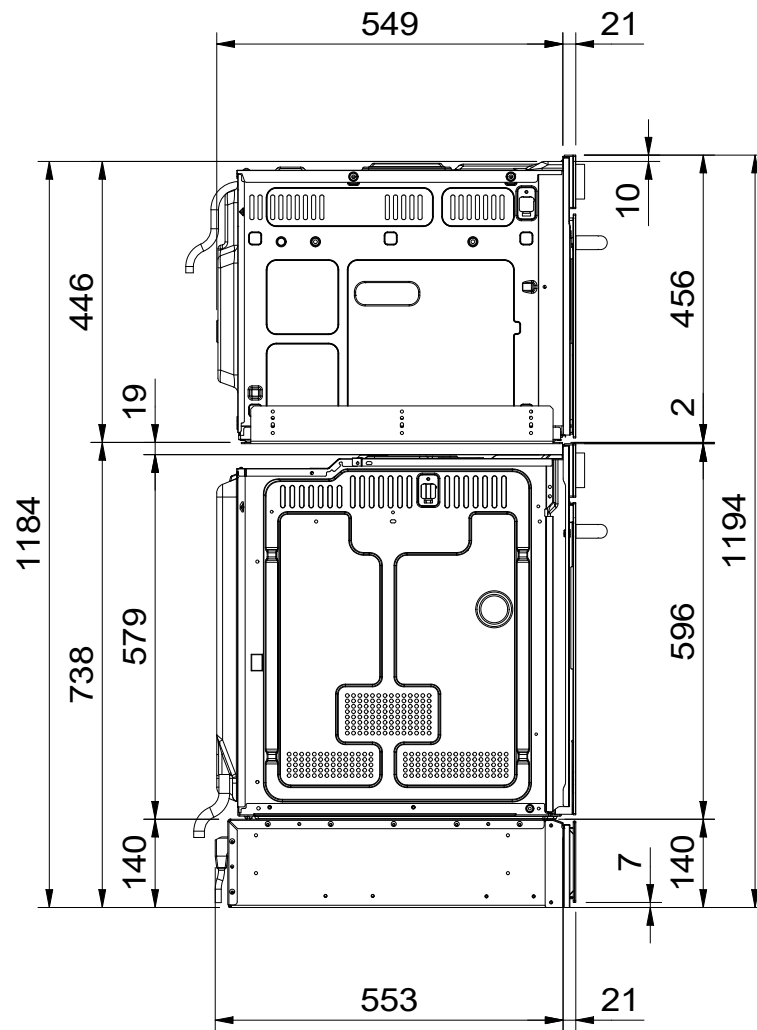
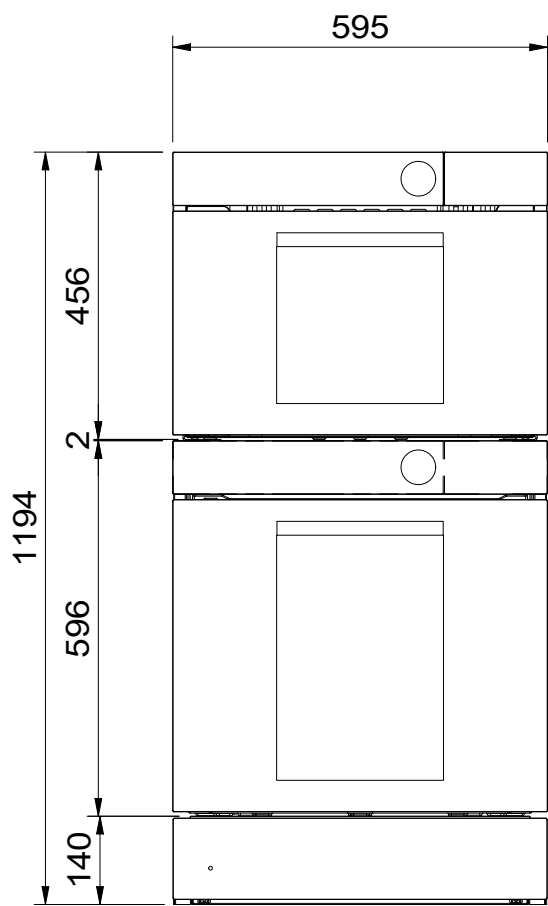

Für dieses Dokument und den darin dargestellten Gegenstand behalten wir uns alle Rechte vor. Vervielfältigung, Bekanntgabe an Dritte oder Verwendung ohne schriftliche, ohne unsere Zustimmung ist verboten. © Copyright 2005 Suter Inox AG. All rights reserved.

 BO110 / BO210 / BO120 / BO220: 230V / 16A, Direktanschluss / Direct wiring / Raccordement électrique / Rollegamento elettrico¹

¹ Anschlusskabel Bauseits
 Connecting wire on site
 Câble de raccordement fourni par le client
 Cavo di collegamento fornito da parte cliente

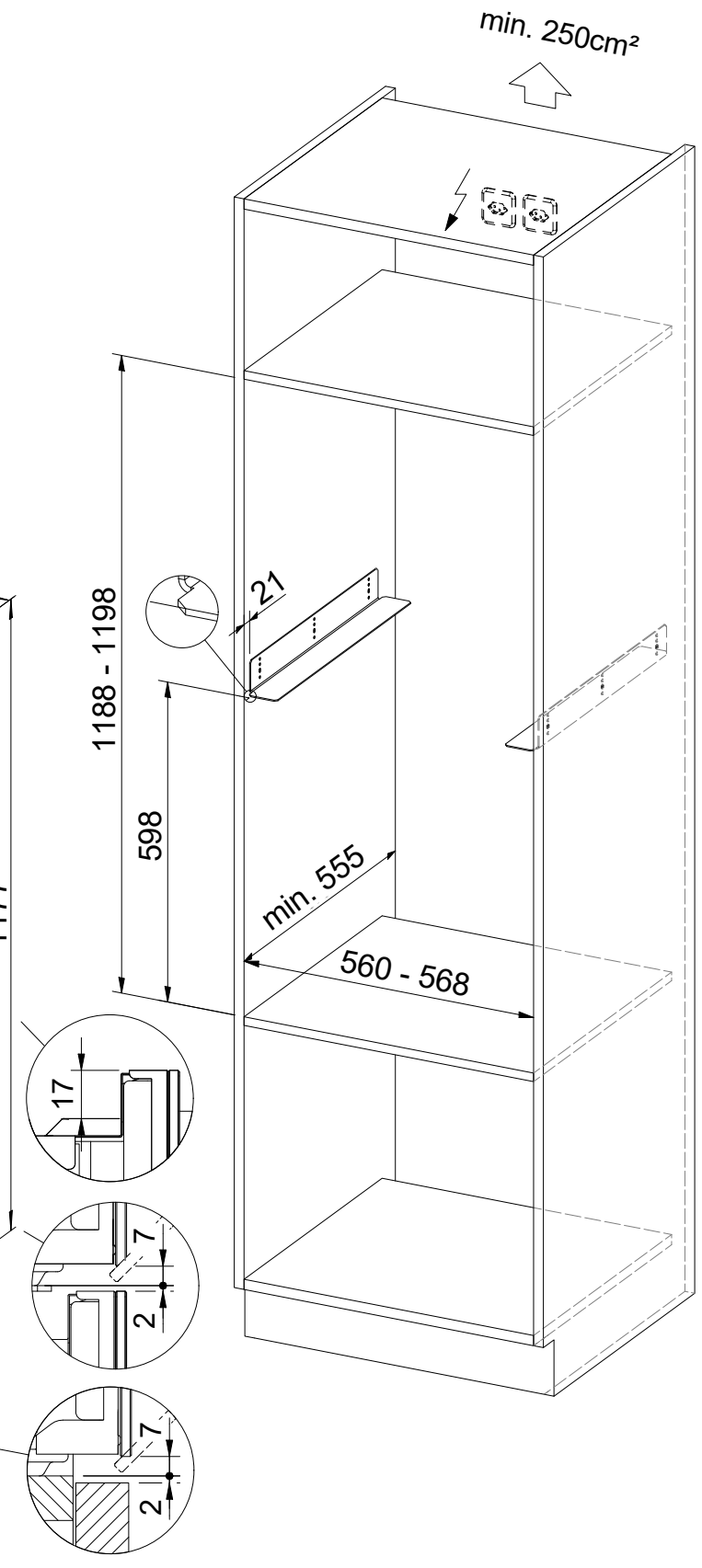
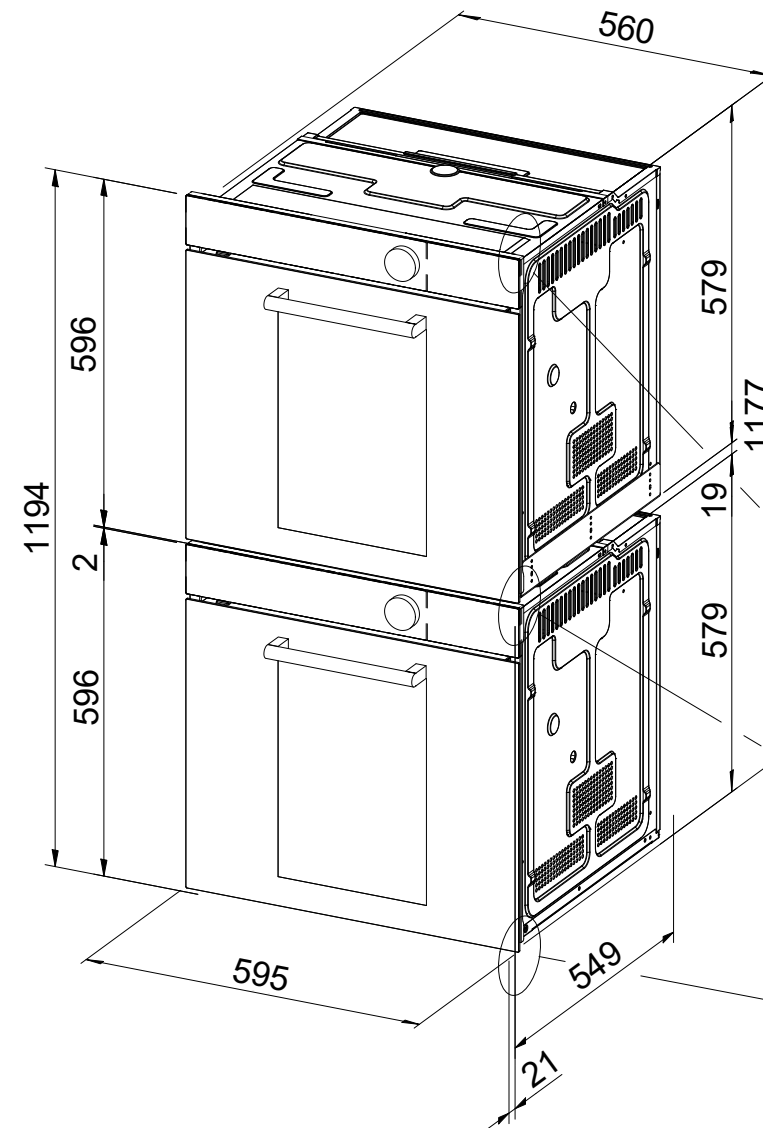
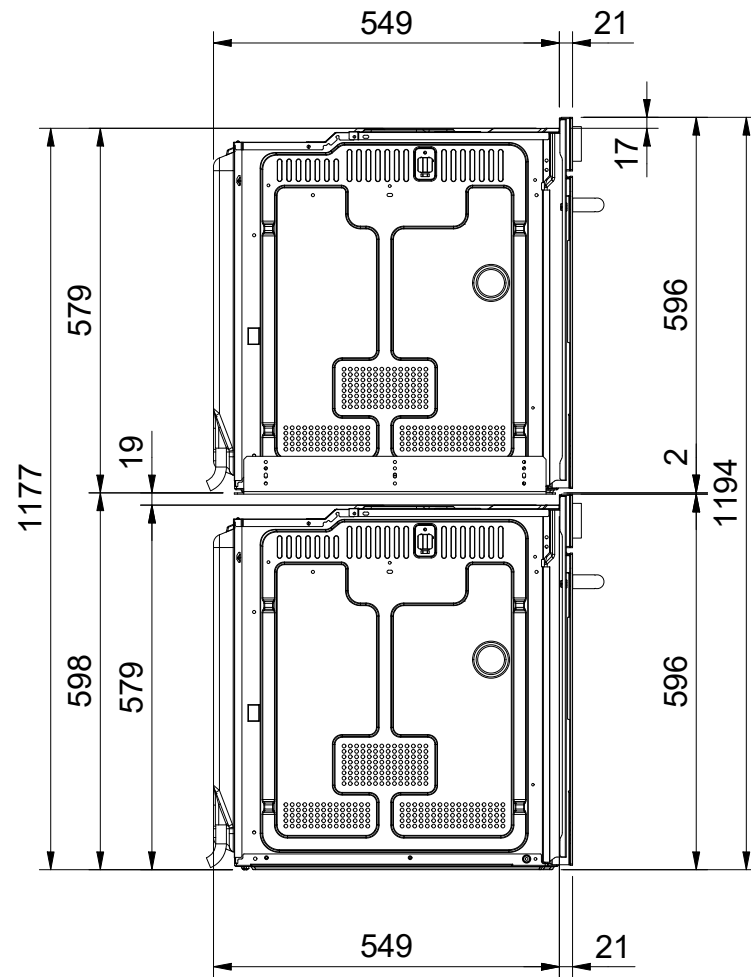
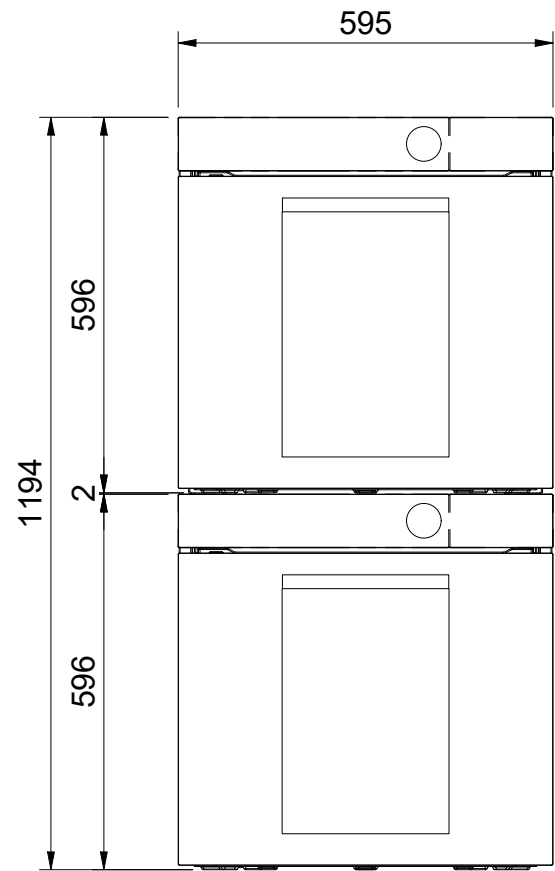

 BO110 / BO210 / BO120 / BO220: 230V / 16A, Direktanschluss / Direct wiring / Raccordement électrique / Rollegamento elettrico¹

 WS100 / WS200: 230V / 10A, T12, 1500mm

¹ Anschlusskabel Bauseits
 Connecting wire on site
 Câble de raccordement fourni par le client
 Cavo di collegamento fornito da parte cliente

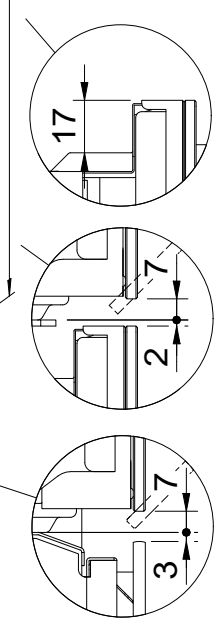
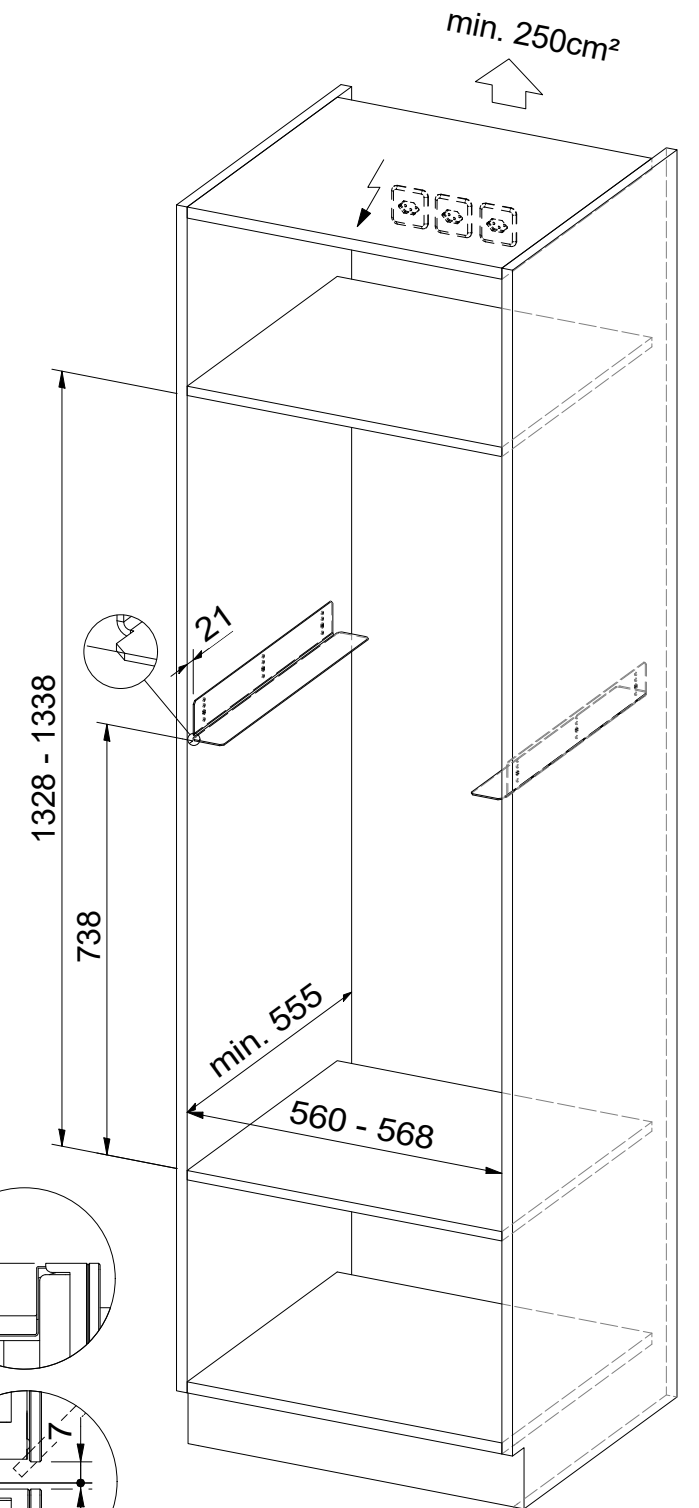
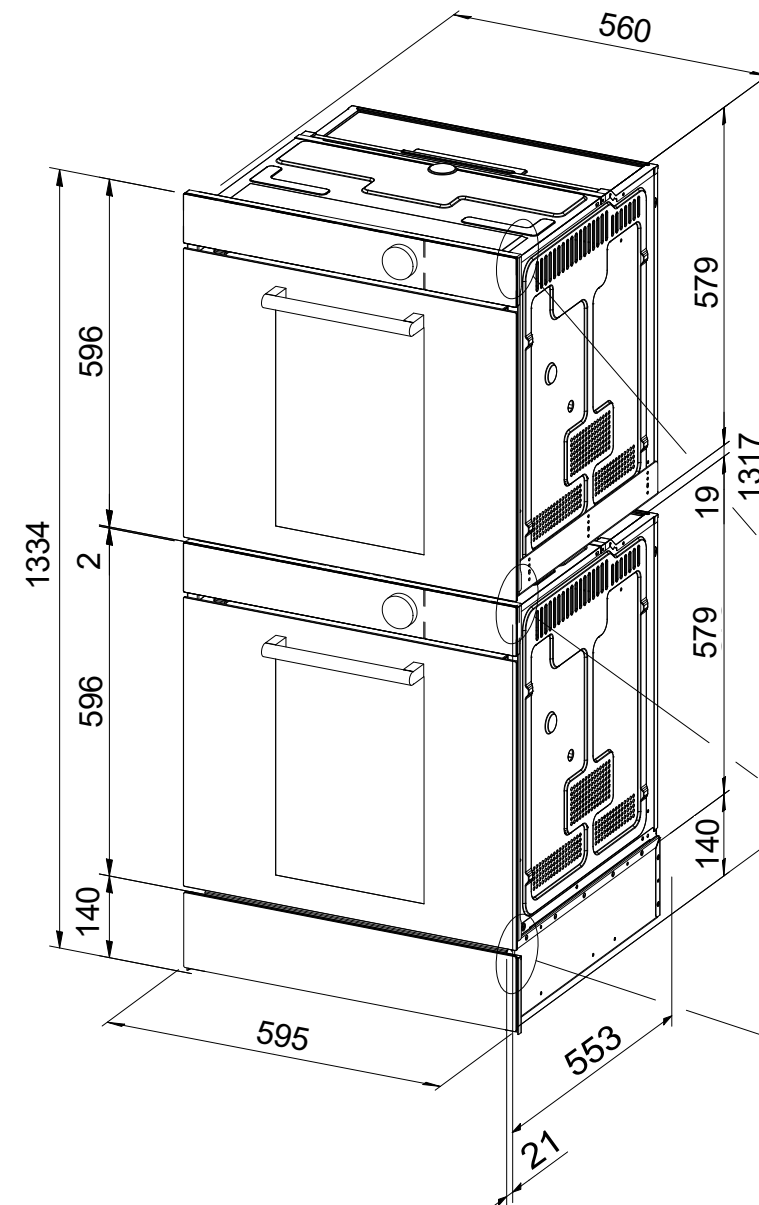
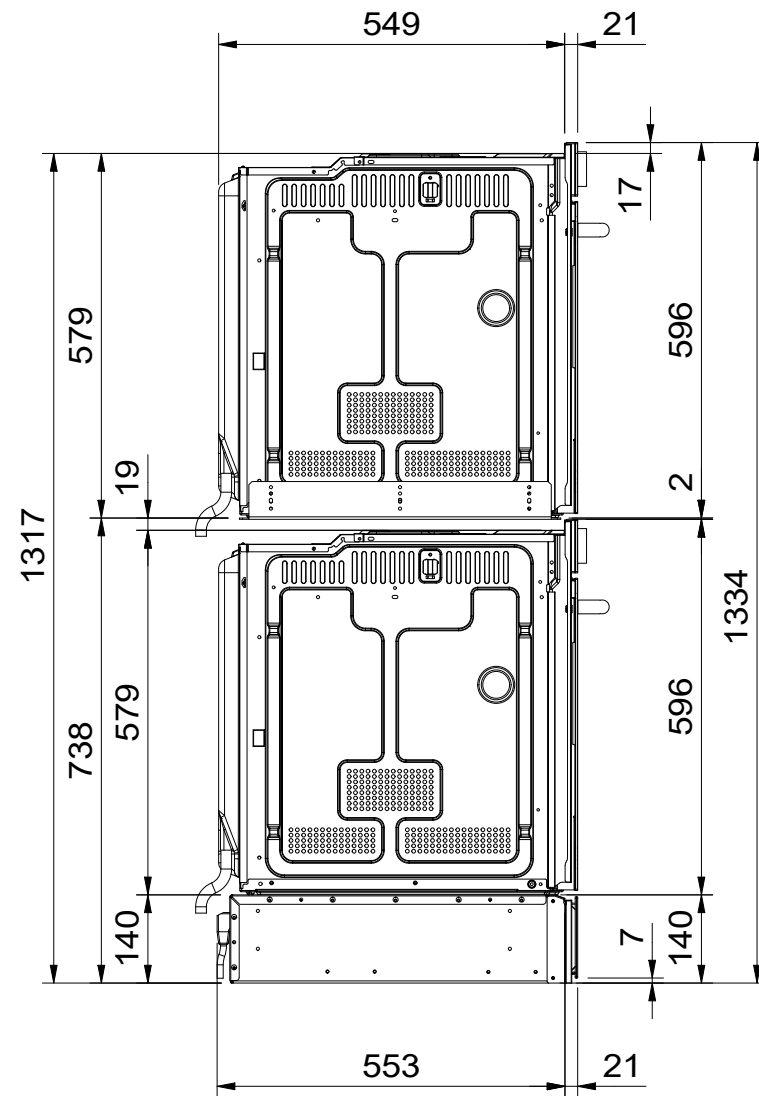
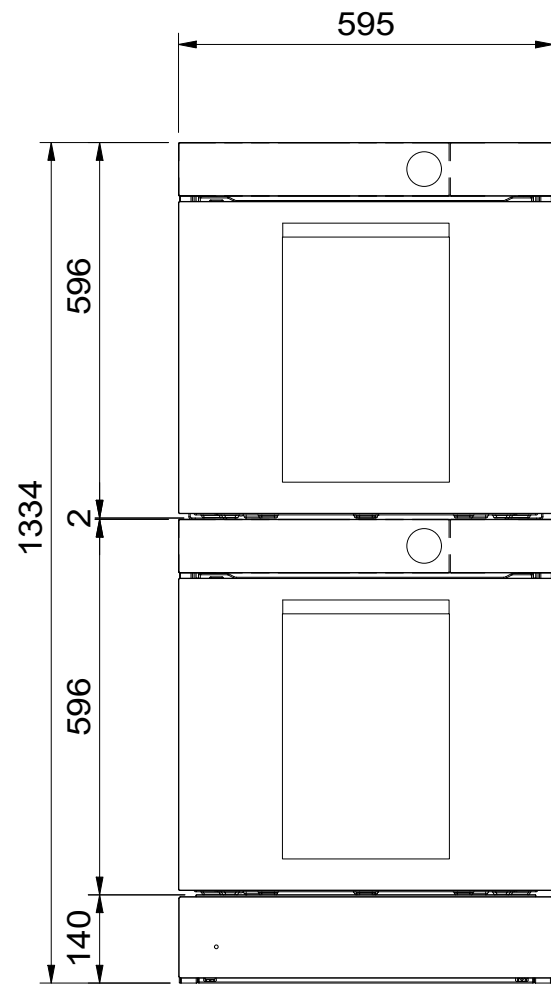

Für dieses Dokument und den darin dargestellten Gegenstand behalten wir uns alle Rechte vor. Vervielfältigung, Bekanntgabe an Dritte oder Verwendung ohne schriftliche Zustimmung ist verboten. © Copyright 2005 Suter Inox AG. All rights reserved.