

Samsung Cassetto scaldavivande WS10/20/30/50

[> Weblink](#)

N. di articolo
500.000.009.00

TRA
7.51
Prezzo in CHF
350.- IVA esclusa

Descrizione del prodotto

Versione costruttiva: **Norma Euro**
GTIN-Nr.: **88806086700887**

Consumi

Consumo energetico

-mantenimento in caldo: 420 W
Consumo energetico: 420 W

Design

Colore: **Nero**

Materiale: **Vetro**

Telaio / materiale: **Si (larghezza: 25 mm) / acciaio inox**

Indicatore e pannello di comando

Display e illuminazione: **Indicatore di stato a LED, arancione**

Pannello di comando: **Manopola (meccanica)**

Proprietà funzionali

Display e illuminazione: **30°C - 80°C**

Graduazione incrementale: **5°C**

Volume vano interno: **25,2 L**

Dimensioni

Altezza : **14 cm**

Larghezza : **59,5 cm**

Profondità (dal frontale del mobile) : **54,5 cm**

Dimensione di pannello frontale : **60 x 15 cm**

Dimensioni apparecchio (A x L x P): **140 x 595 x 545 mm**

Peso a vuoto

Peso dell'apparecchio: **16,3 kg**

Dotazioni

Misure interne (altezza / larghezza / profondità) : **100 x 500 x 470 mm**

Vano interno: **acciaio inox**

Fondo: **Tappetino antiscivolo**

Cassetto: **Guide telescopiche**

Volume: **25,2 L**

Numero di ripiani: **1**

Illuminazione / finestra: **- / -**

Guide telescopiche estraibili: **Si**

Portata: **fino a 25 kg**

Funzioni

Scongelamento: **30°C**

Lievitazione impasti: **40°C bis 50°C**

Preriscaldamento tazzine: **40°C bis 50°C**

Preriscaldamento stoviglie: **60°C bis 70°C**

Scaldavivande: **80°C**

Capacità di carico

Tazzine da caffè: **max. 80 pz**

Piatti (28 cm): **max. 20 pz**

Allacciamento elettrico

Tensione di attacco: **230 V**

Frequenza: **50 Hz**

Potenza allacciata: **0,42 kWh**

Protezione: **10 A**

Lunghezza cavo di allacciamento: **1,5 m**

Connettore di alimentazione: **Connettore Schuko con adattatore CH (10A, tipo 12)**

Samsung Cassetto scaldavivande WS10/20/30/50[> Weblink](#)**Dati tecnici**Standard di larghezza: **Euro-Norm 60 cm**

Standard di larghezza: -

Altezza di nicchia: **di 142 - 600 mm**Larghezza di nicchia: **di 560 - max. 568 mm**Profondità di nicchia: **min. 550 mm**Misure di nicchia (A x L x P): **140-595 x 560-568 x min 550 mm**Larghezza apparecchio in mm: **595 mm**Altezza apparecchio in mm: **140 mm**Profondità apparecchio in mm: **545 mm****Imballaggio**Peso, imballaggio incluso: **18,3 kg**Misure imballaggio (A x L x P): **250 x 670 x 650 mm****Accessorio**

Accessori opzionali

[> Weblink](#)

500.000.074.00 / CHF

60.-

Set di squadrette di supporto

Prodotti compatibili[> Weblink](#)

500.000.001.00 / CHF

880.-

Forno BO20 Dual Door
(Dual Cook Flex)[> Weblink](#)

500.000.002.00 / CHF

770.-

Forno BO30 Dual Door
(Dual Cook Flex)[> Weblink](#)

500.000.006.00 / CHF

520.-

Apparecchio compatto
Samsung, forno con
microonde BM30/50

Samsung Backöfen und Kompaktgeräte: Masszeichnungen

Forni e apparecchi compatti Samsung: disegni quotati

Samsung Backofen BO10 Gourmet Vapour

Forno Samsung BO10 Gourmet Vapour

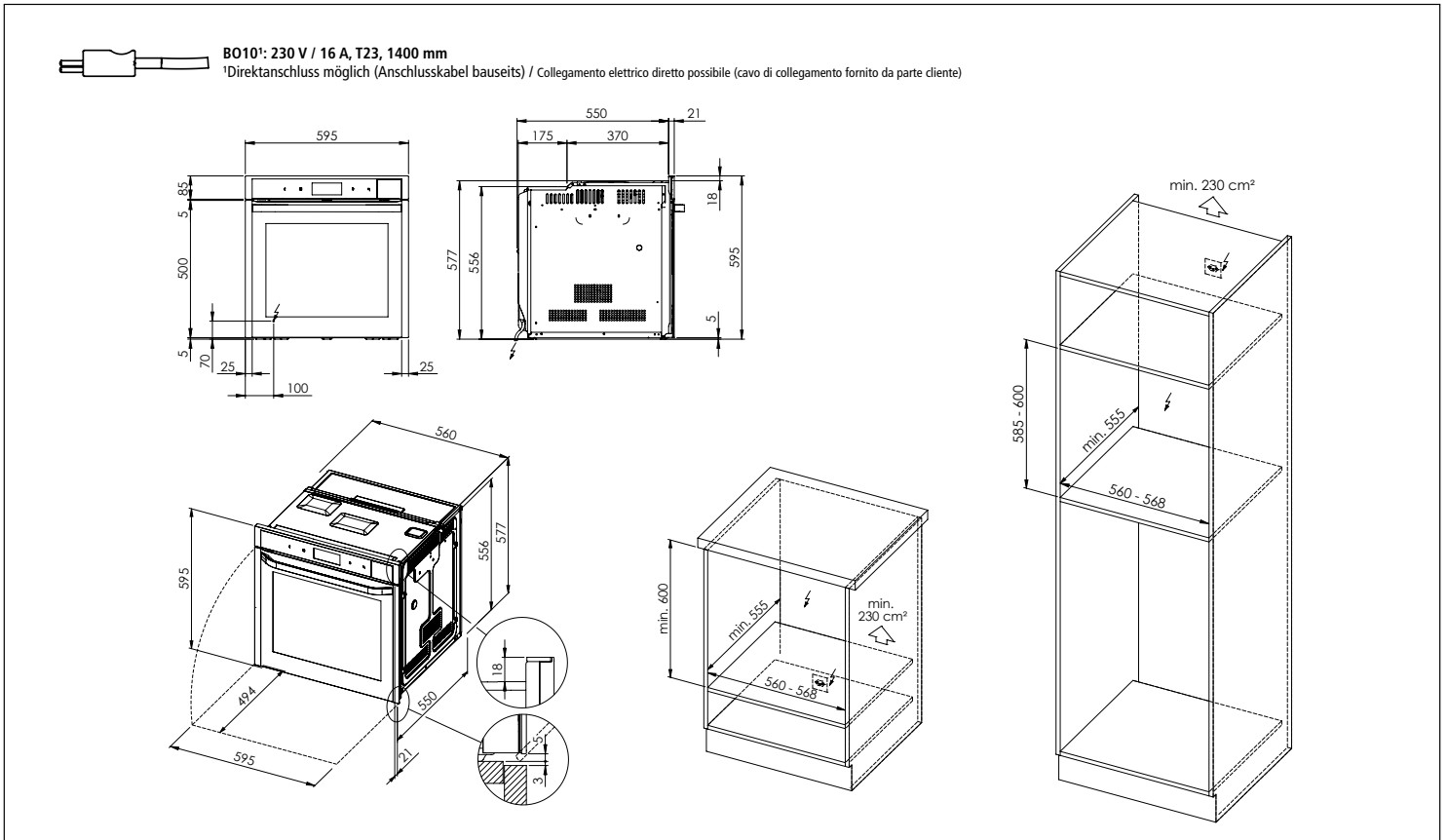

Samsung Backofen BO10 Gourmet Vapour mit Wärmeschublade WS10/20/30/50

Forno Samsung BO10 Gourmet Vapour con cassetto scaldavivande WS10/20/30/50

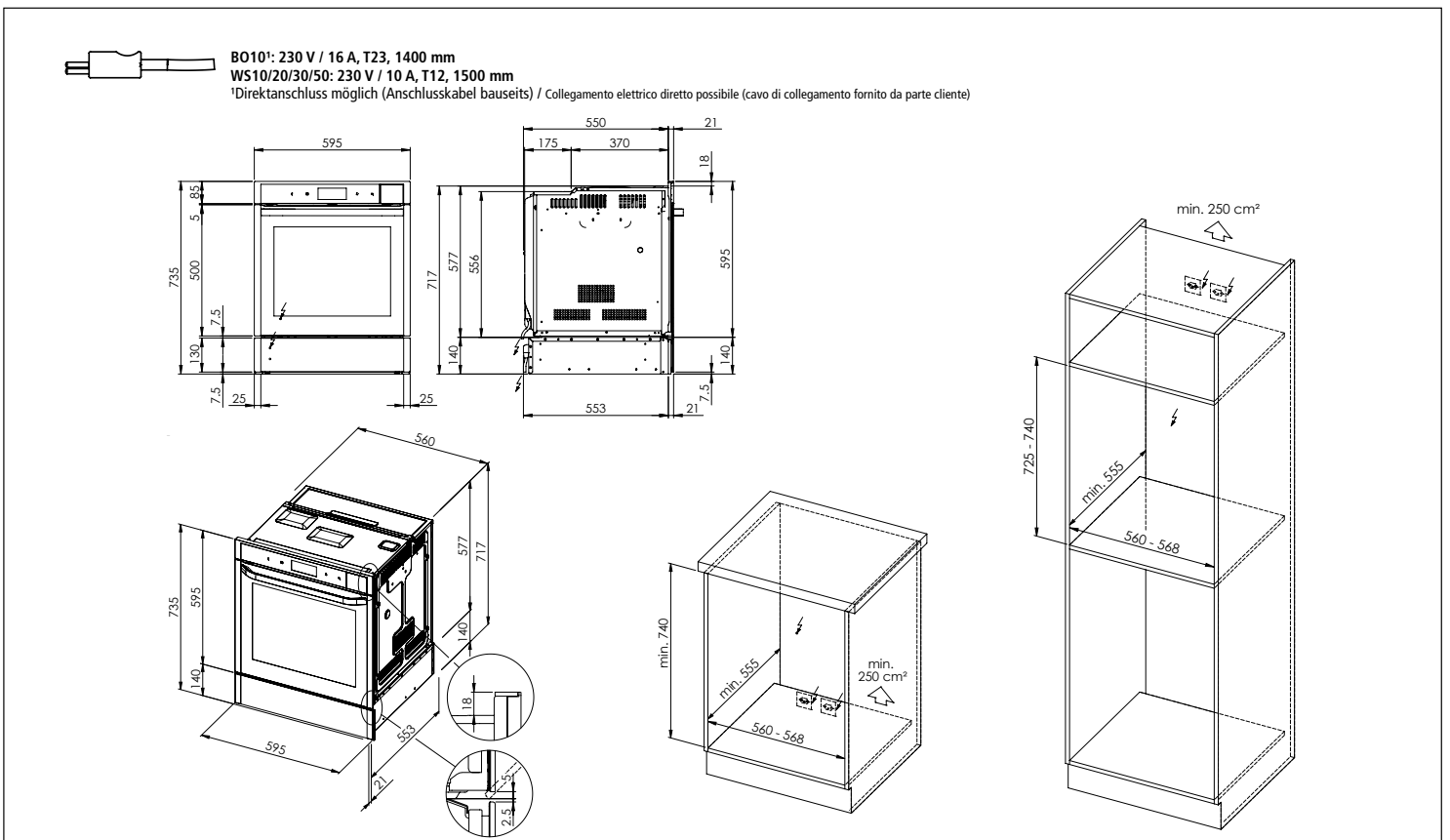

Samsung Backöfen und Kompaktgeräte: Masszeichnungen

Forni e apparecchi compatti Samsung: disegni quotati

Samsung Backofen BO20 Dual Door

Forno Samsung BO20 Dual Door

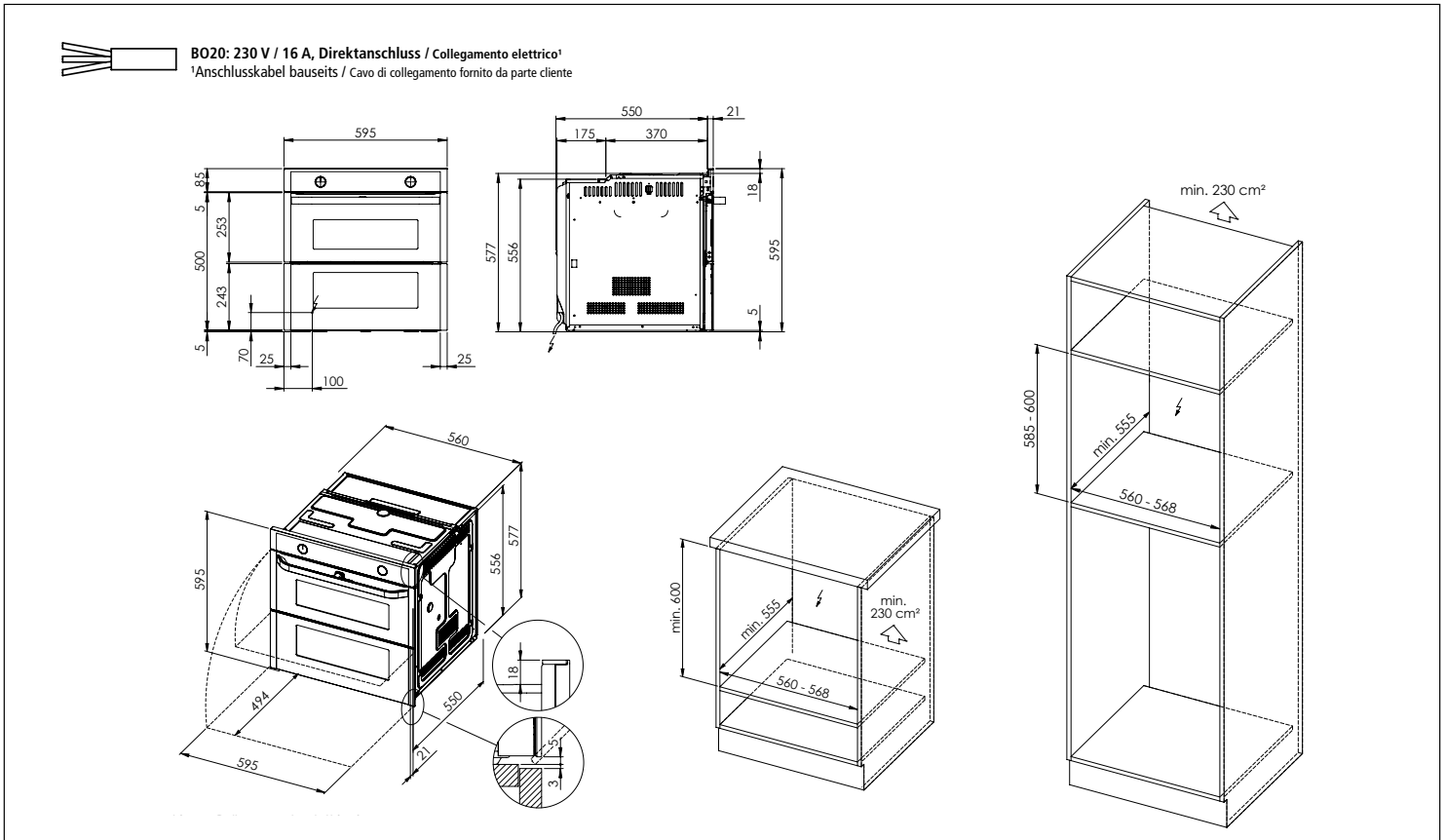

Samsung Backofen BO20 Dual Door mit Wärmeschublade WS10/20/30/50

Forno Samsung BO20 Dual Door con cassetto scaldavivande WS10/20/30/50

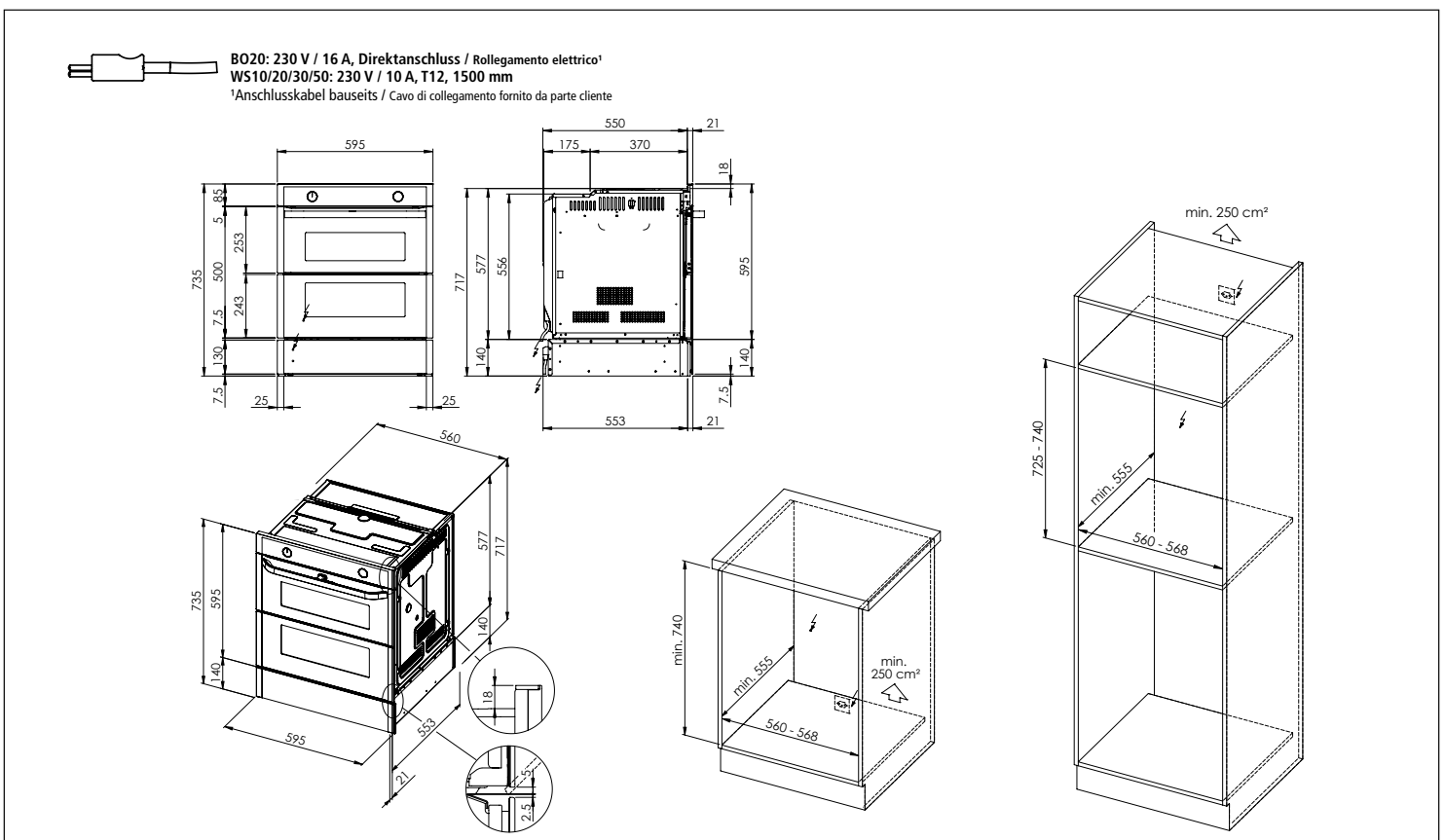

Samsung Backöfen und Kompaktgeräte: Masszeichnungen Forni e apparecchi compatti Samsung: disegni quotati

Samsung Backofen BO30 Dual Door Forno Samsung BO30 Dual Door

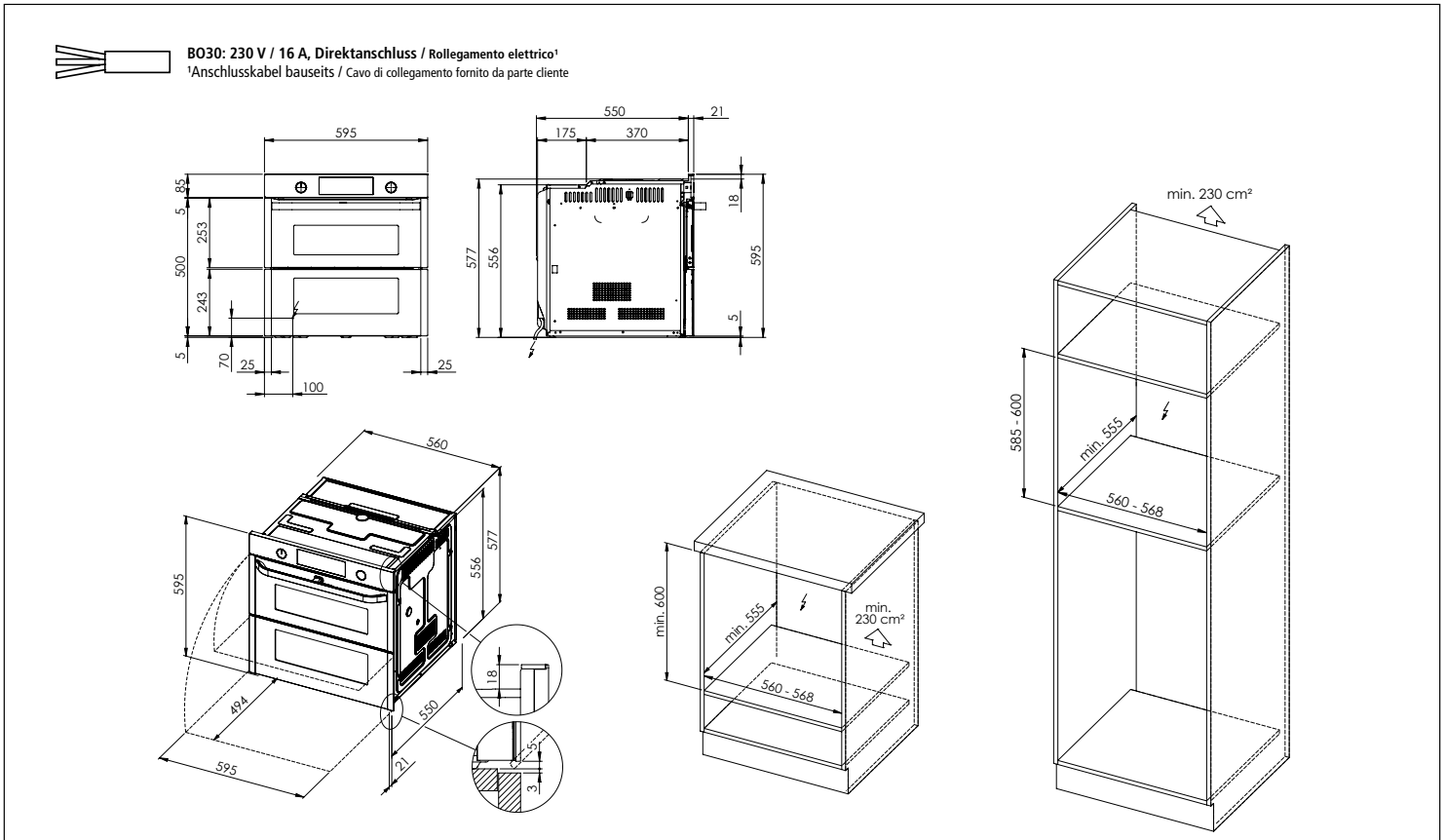

Samsung Backofen BO30 Dual Door mit Wärmeschublade WS10/20/30/50 Forno Samsung BO30 Dual Door con cassetto scaldavivande WS10/20/30/50

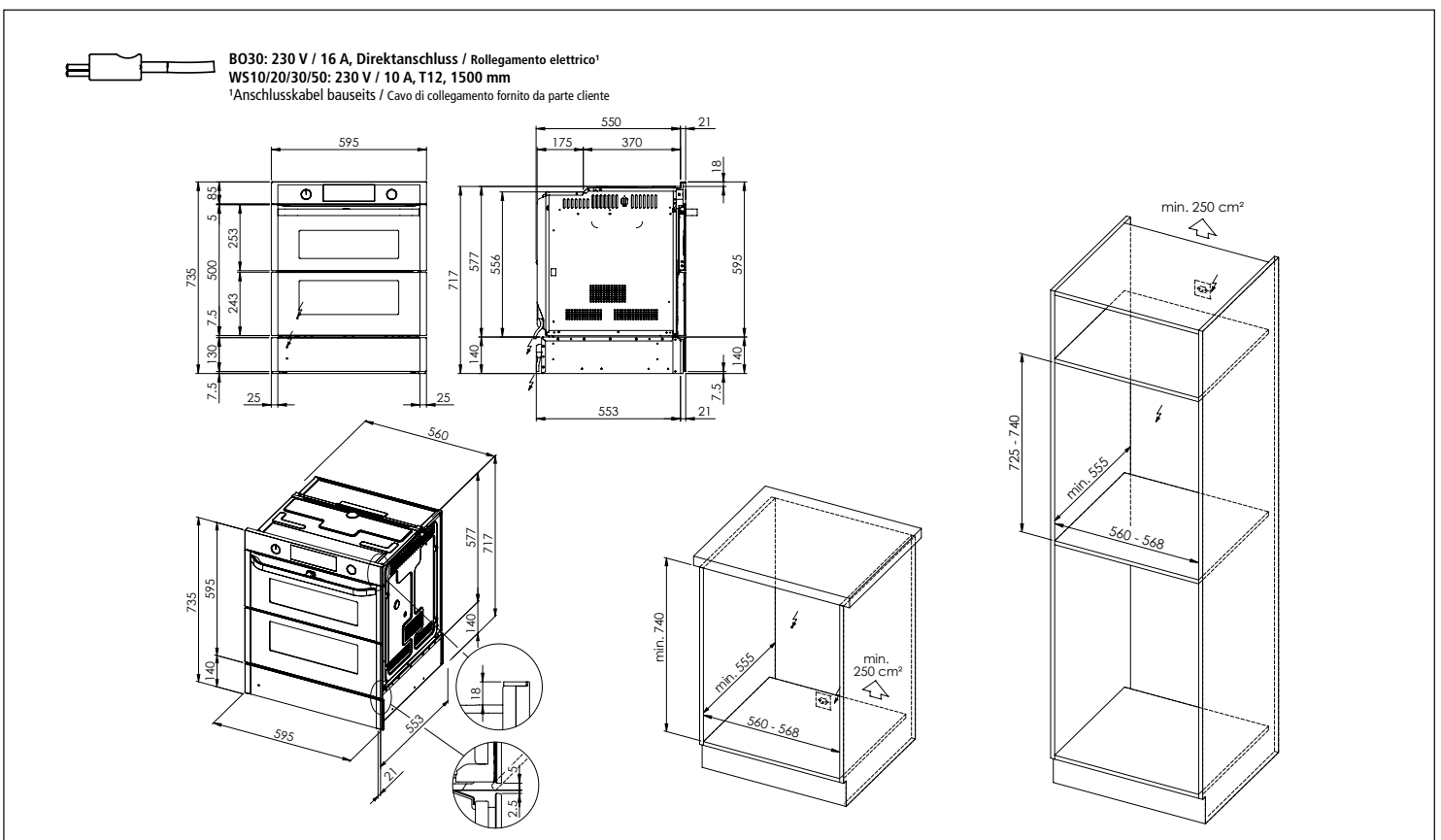

Samsung Backöfen und Kompaktgeräte: Masszeichnungen Forni e apparecchi compatti Samsung: disegni quotati

Samsung Backofen BO50 Dual Cook Forno Samsung BO50 Dual Cook

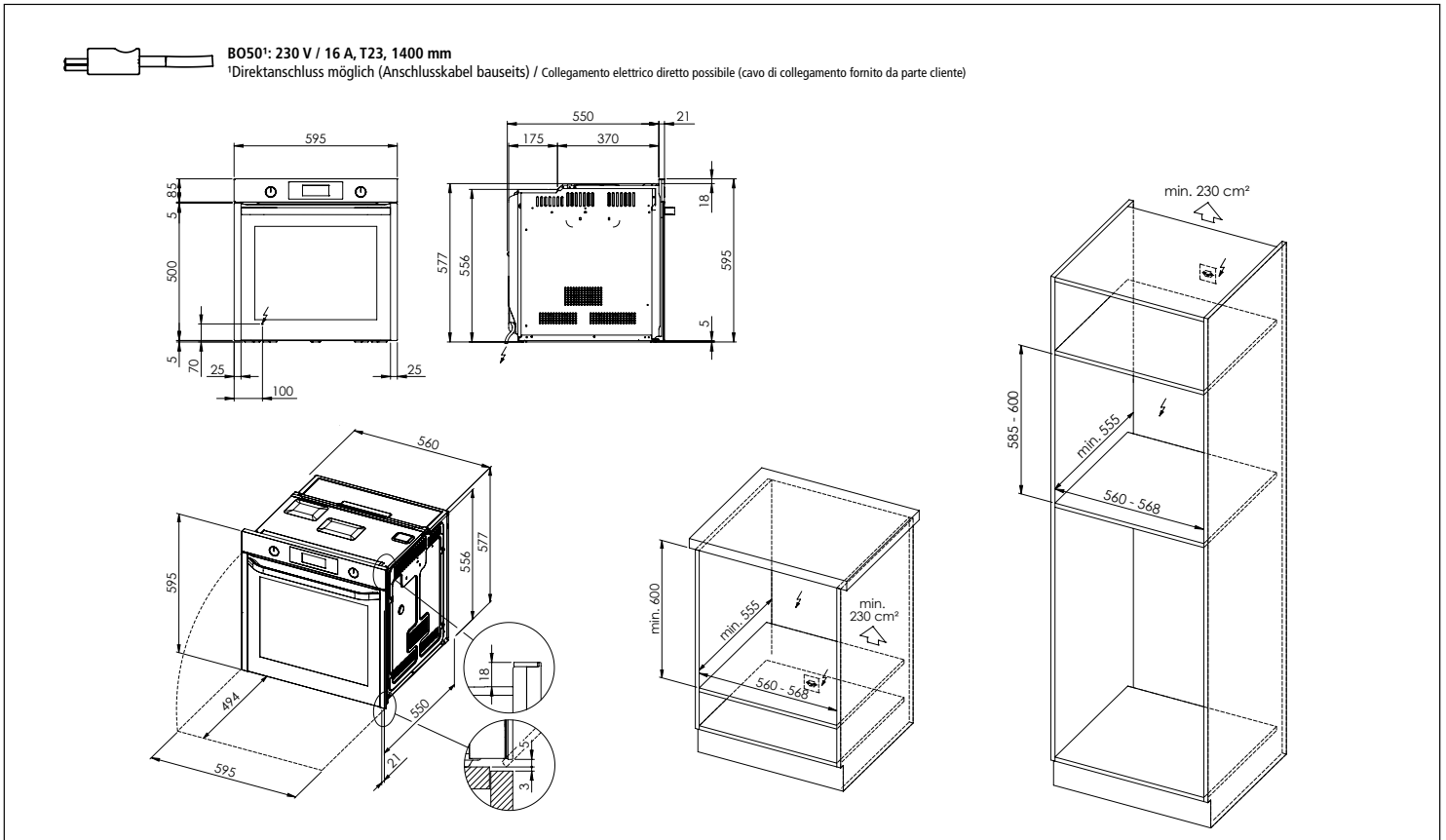

Samsung Backofen BO50 Dual Cook mit Wärmeschublade WS10/20/30/50 Forno Samsung BO50 Dual Cook con cassetto scaldavivande WS10/20/30/50

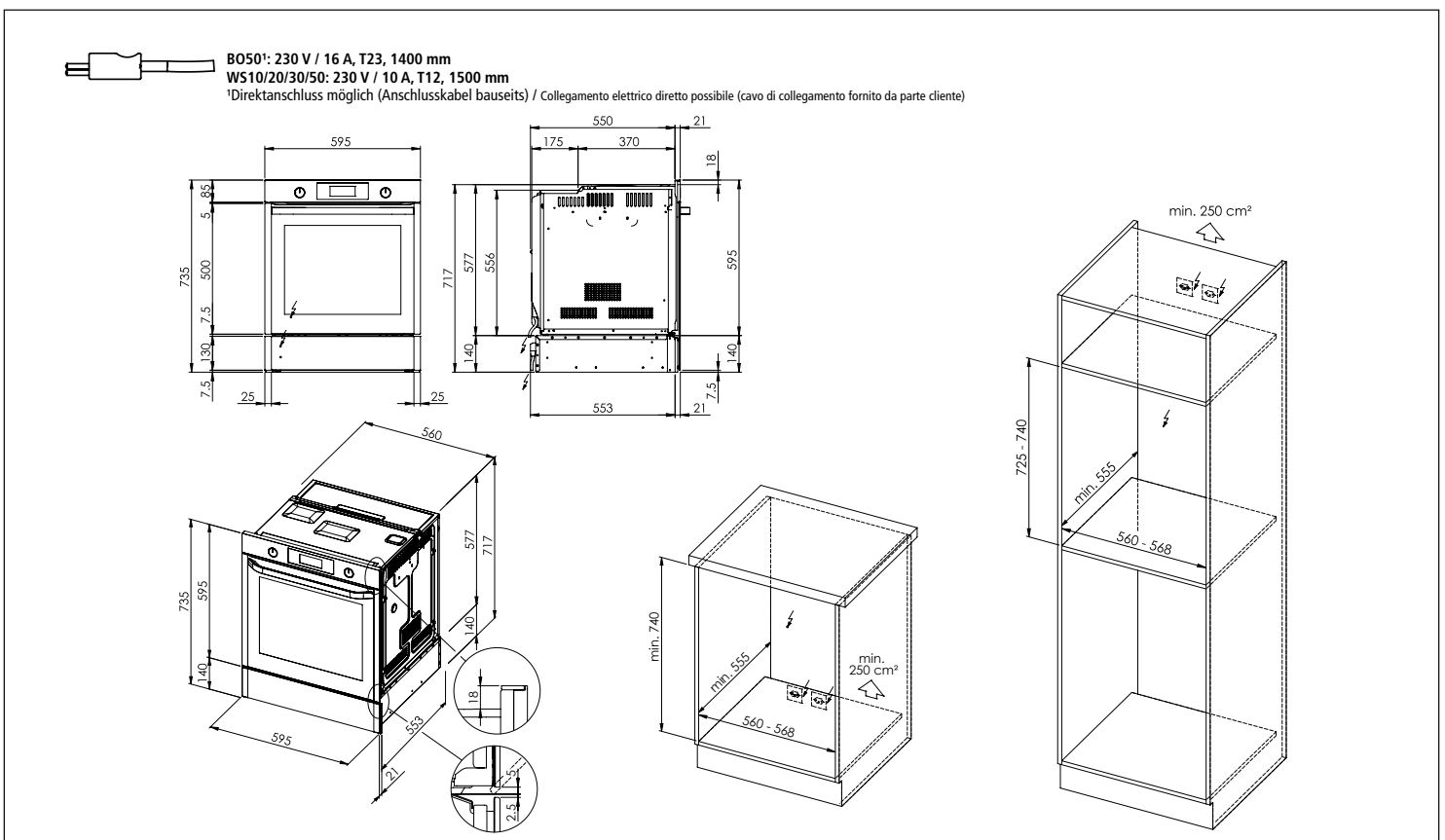

Samsung Backöfen und Kompaktgeräte: Masszeichnungen

Forni e apparecchi compatti Samsung: disegni quotati

Samsung Backofen BO60 Dual Fan

Forno Samsung BO60 Dual Fan

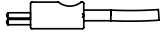

BO60¹: 230 V / 16 A, T23, 1400 mm

¹Direktanschluss möglich (Anschlusskabel bauseits) / Collegamento elettrico diretto possibile (cavo di collegamento fornito da parte cliente)

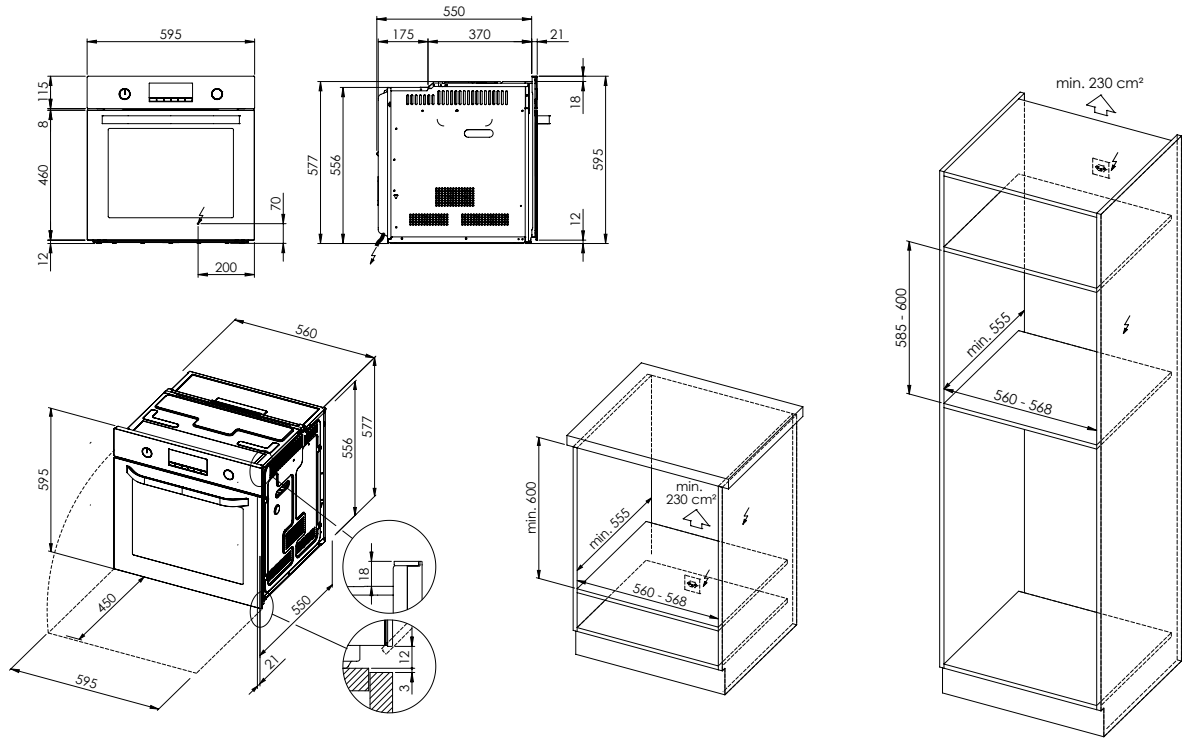

Samsung Backofen BO70 Dual Fan

Forno Samsung BO70 Dual Fan

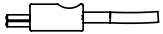

BO70¹: 230 V / 16 A, T23, 1400 mm

¹Direktanschluss möglich (Anschlusskabel bauseits) / Collegamento elettrico diretto possibile (cavo di collegamento fornito da parte cliente)

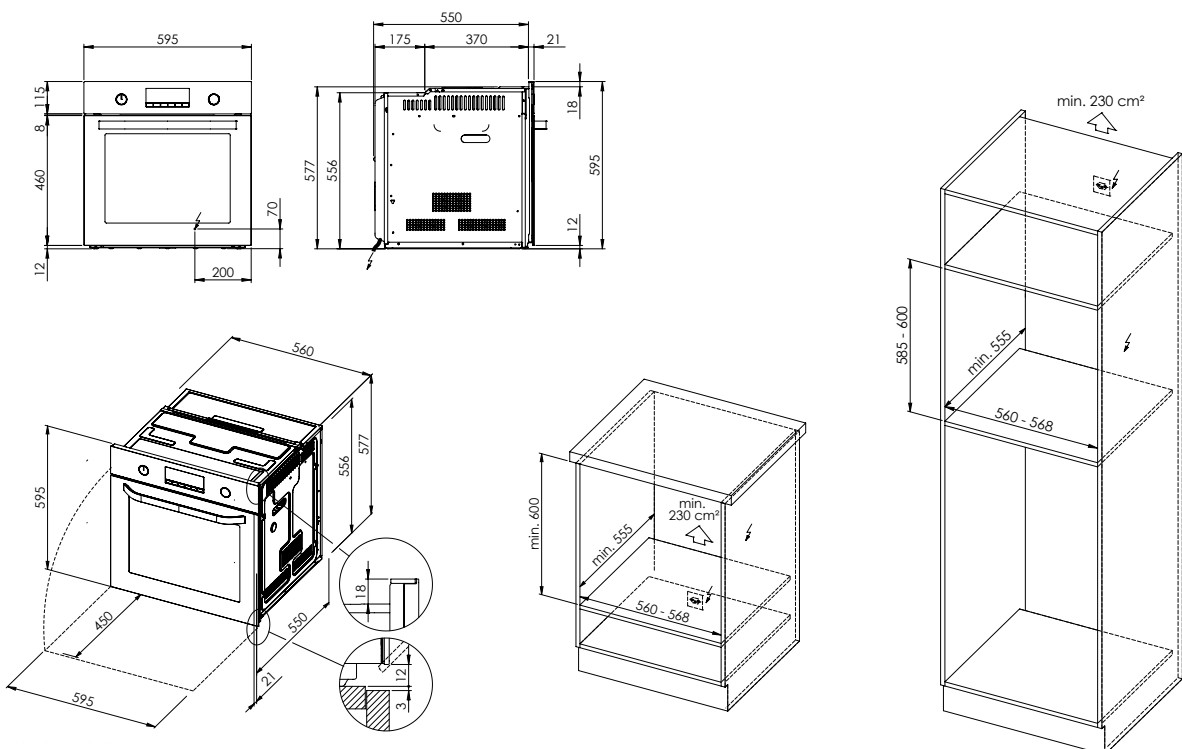

Samsung Backöfen und Kompaktgeräte: Masszeichnungen Forni e apparecchi compatti Samsung: disegni quotati

Samsung Combi-Steamer CS40 Kompaktgerät Apparecchio compatto: Combi Steamer Samsung CS40

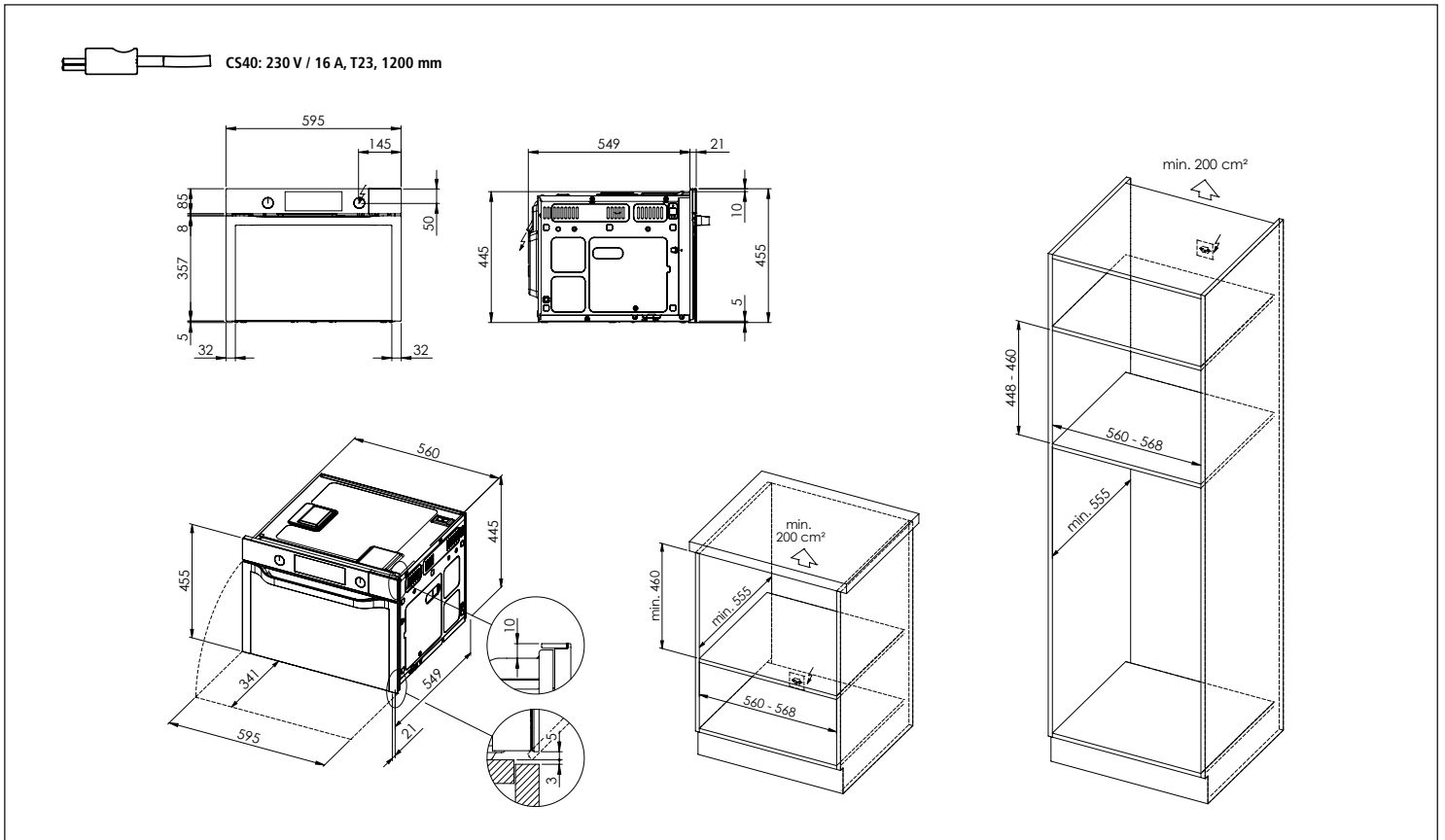

Samsung Combi-Steamer CS40 Kompaktgerät mit Wärmeschublade WS40 Apparecchio compatto: Combi Steamer Samsung CS40 + cassetto scaldavivande WS40

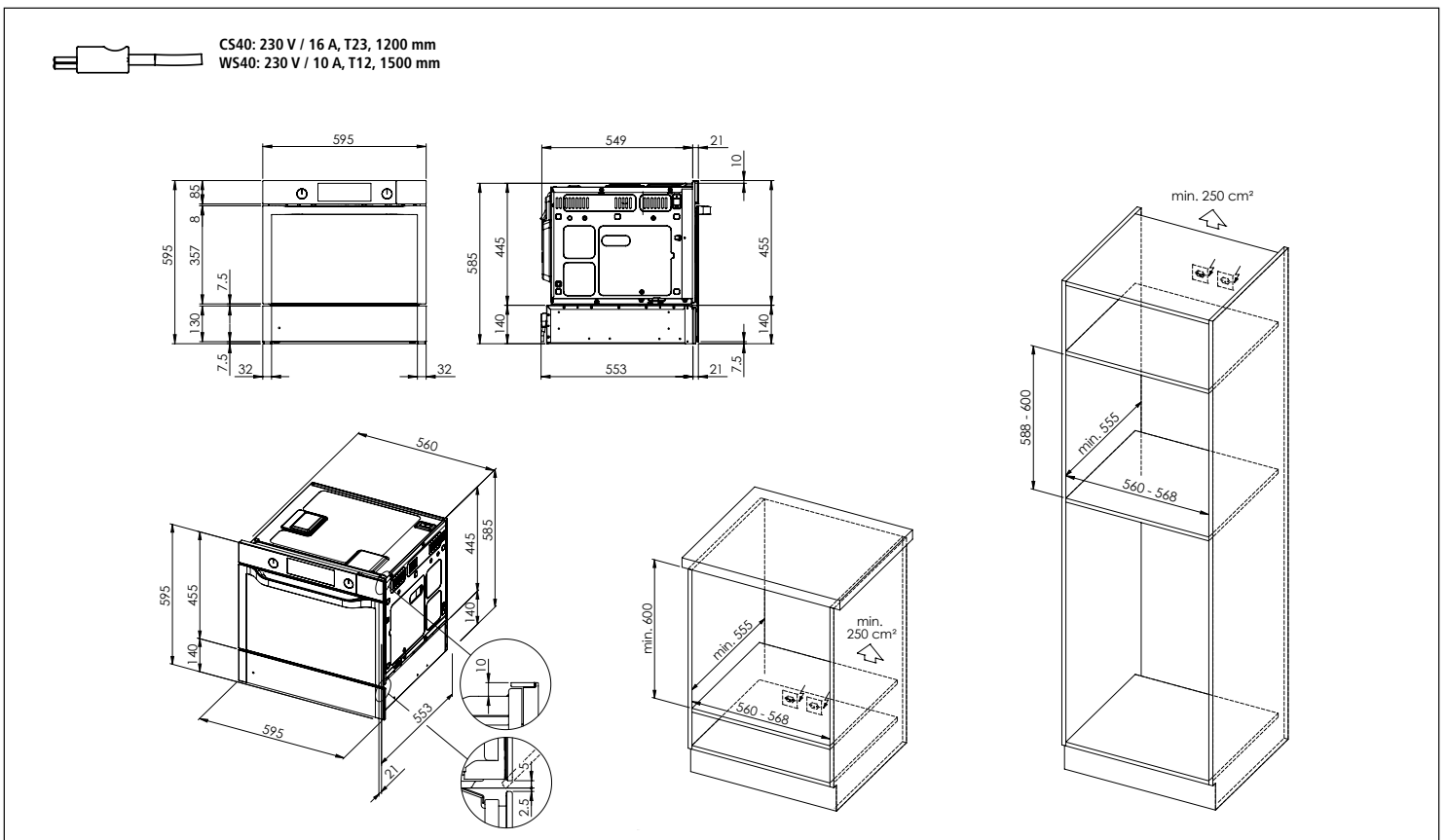

Samsung Backöfen und Kompaktgeräte: Masszeichnungen Forni e apparecchi compatti Samsung: disegni quotati

Set Angebot «Combi-Steamer 2 x CS40»
Offerta di set «Combi Steamer 2 x CS40»

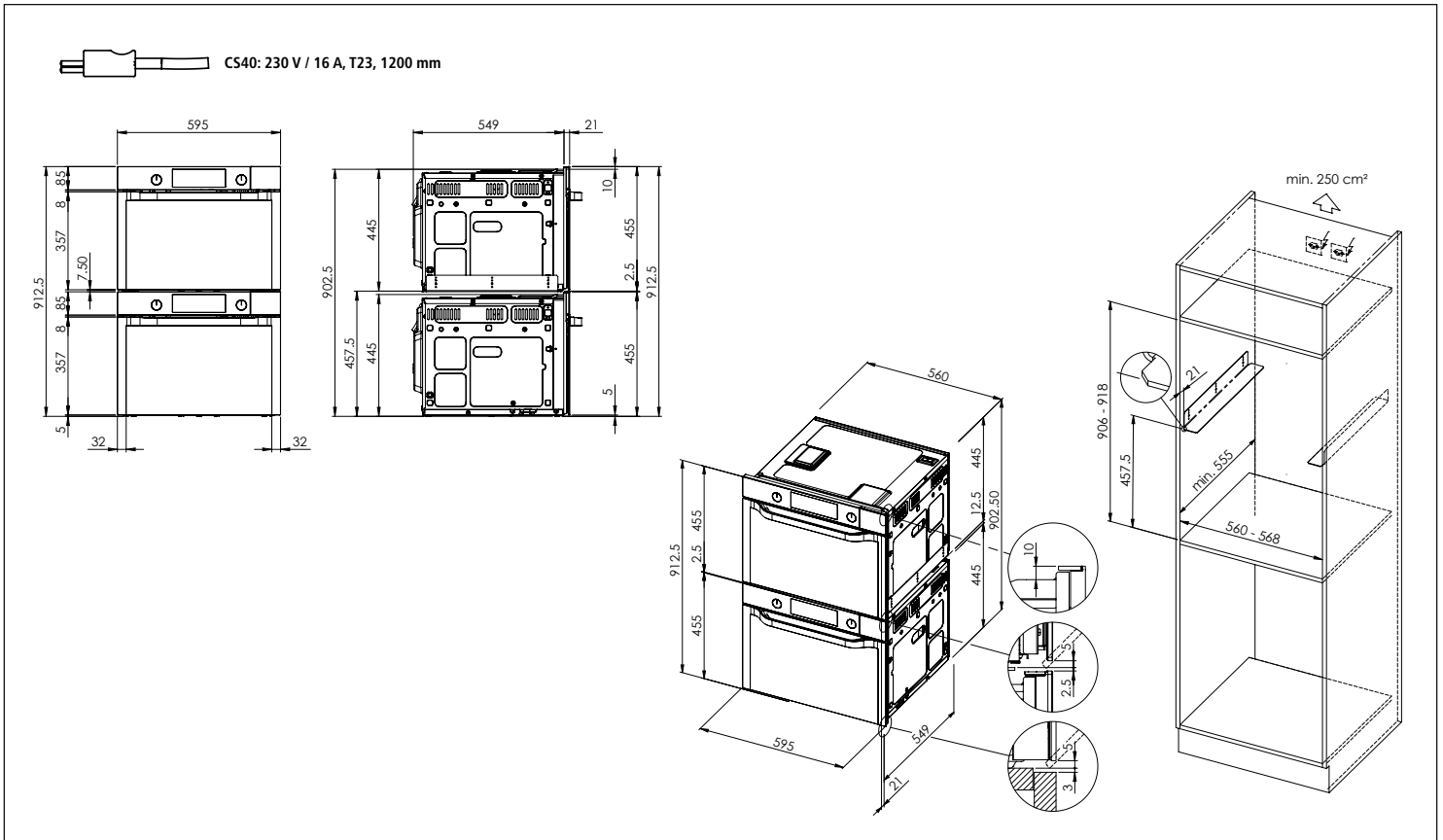

Set Angebot «Combi-Steamer 2 x CS40 + Wärmeschublade WS40»
Offerta di set «Combi Steamer 2 x CS40 + cassetto scaldavivande WS40»

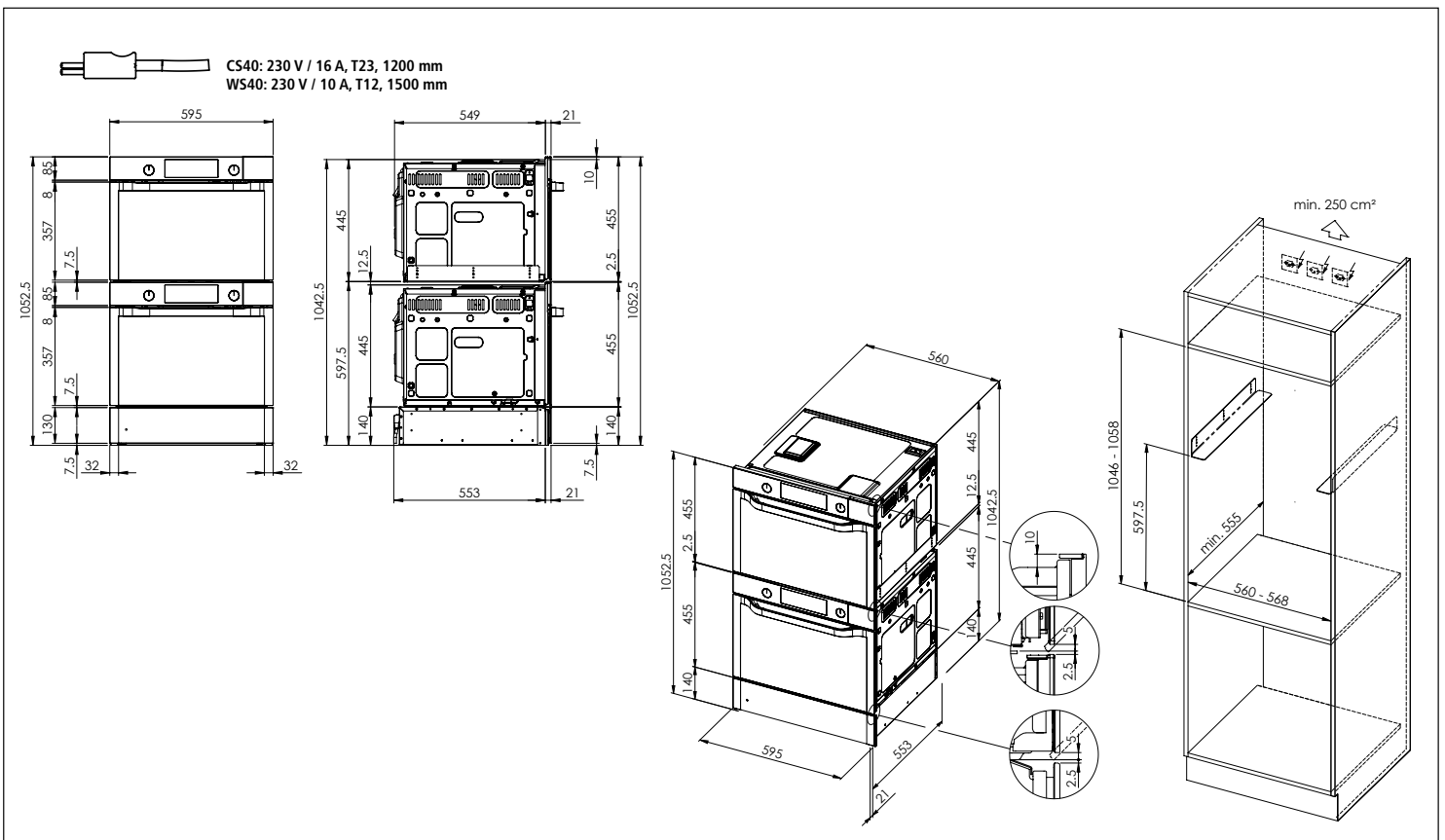

Samsung Backöfen und Kompaktgeräte: Masszeichnungen

Forni e apparecchi compatti Samsung: disegni quotati

Samsung Backofen mit Mikrowelle BM30/50 Kompaktgerät
Apparecchio compatto: forno con microonde Samsung BM30/50

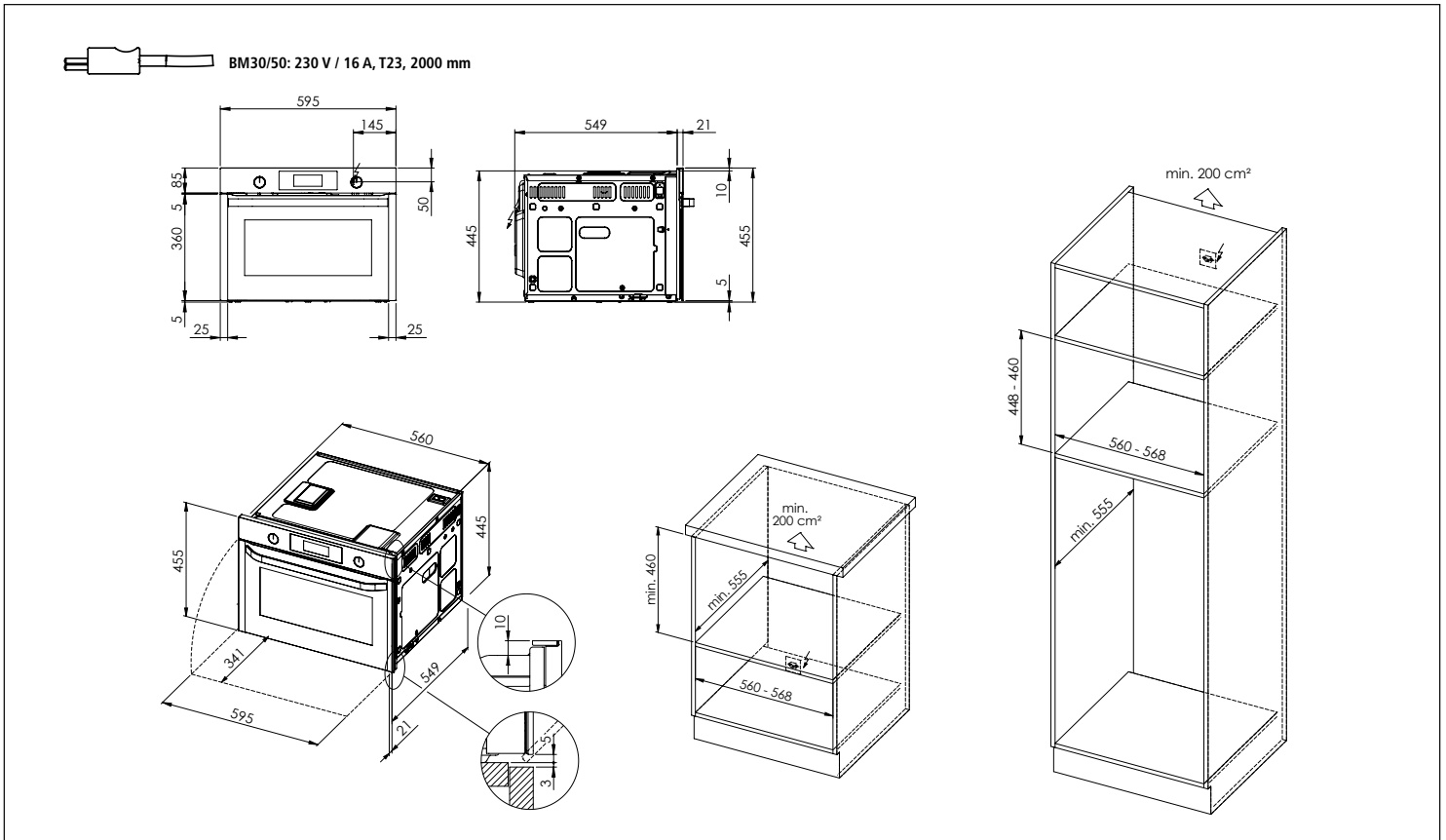

Samsung Backofen mit Mikrowelle BM30/50 Kompaktgerät mit Wärmeschublade WS10/20/30/50
Apparecchio compatto: forno con microonde Samsung BM30/50 con cassetto scaldavivande WS10/20/30/50

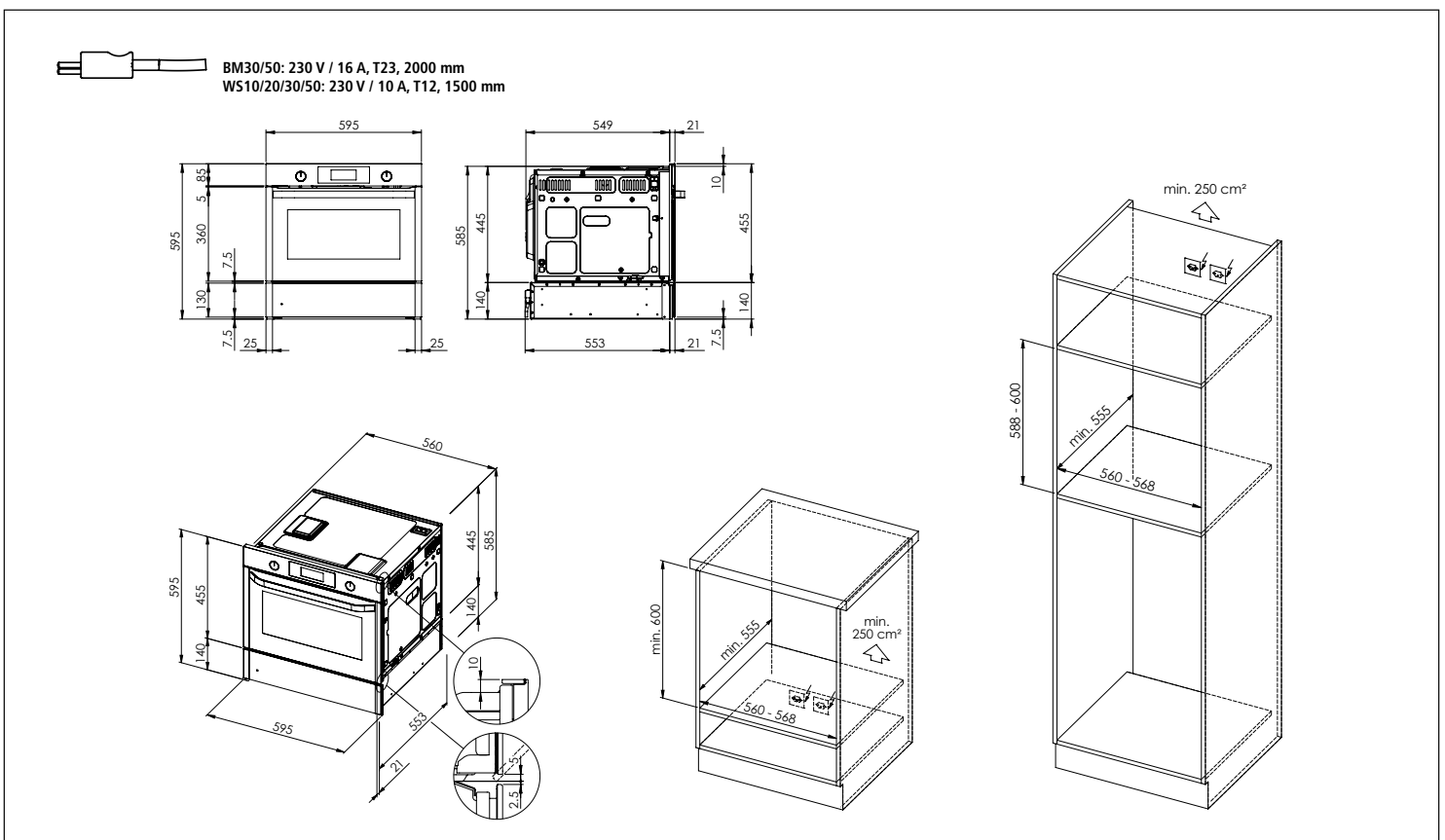

Samsung Backöfen und Kompaktgeräte: Masszeichnungen Forni e apparecchi compatti Samsung: disegni quotati

Samsung Wärmeschublade WS10/20/30/50
Cassetto scaldavivande Samsung WS10/20/30/50

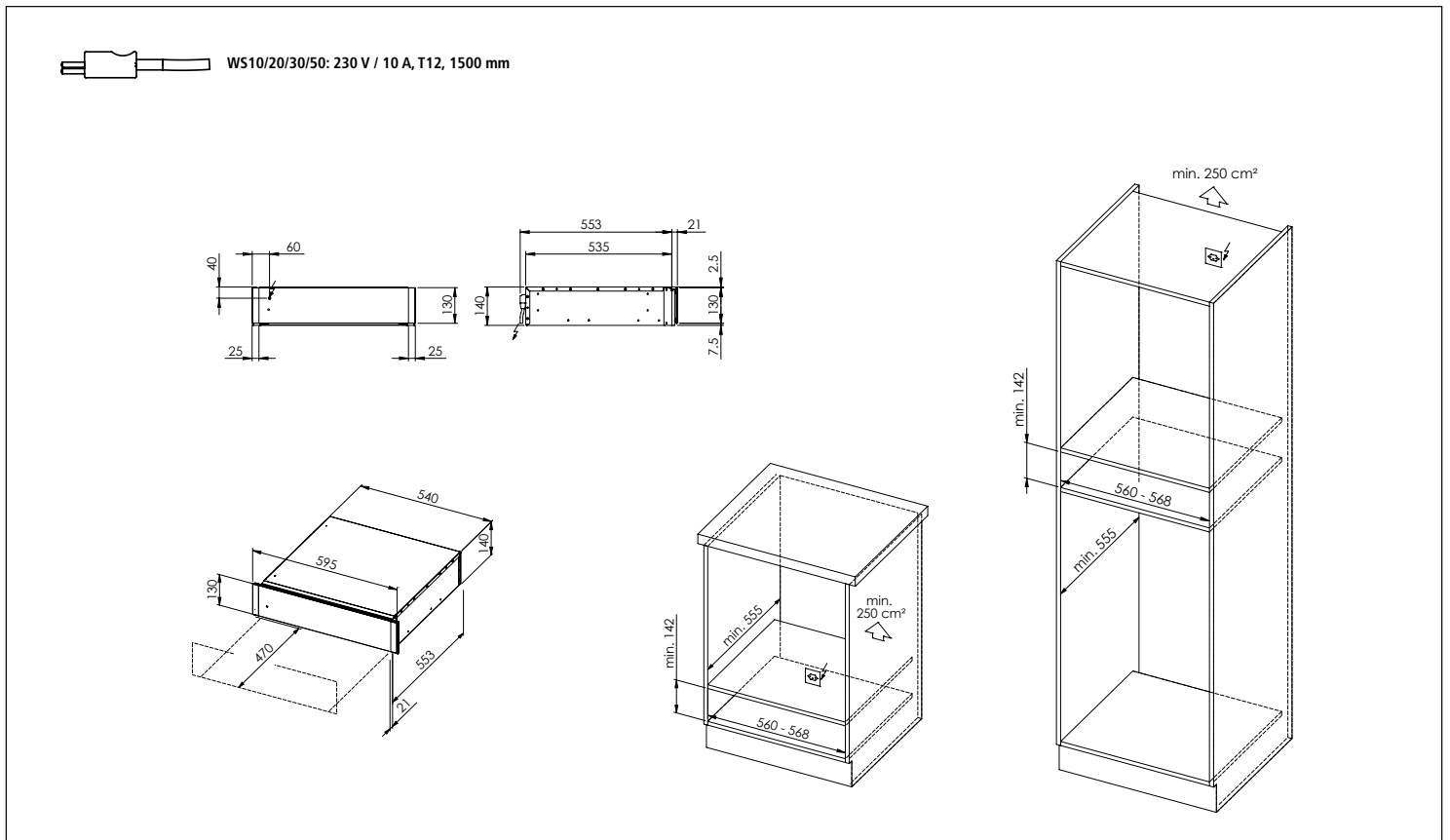

Samsung Wärmeschublade WS40
Cassetto scaldavivande Samsung WS40

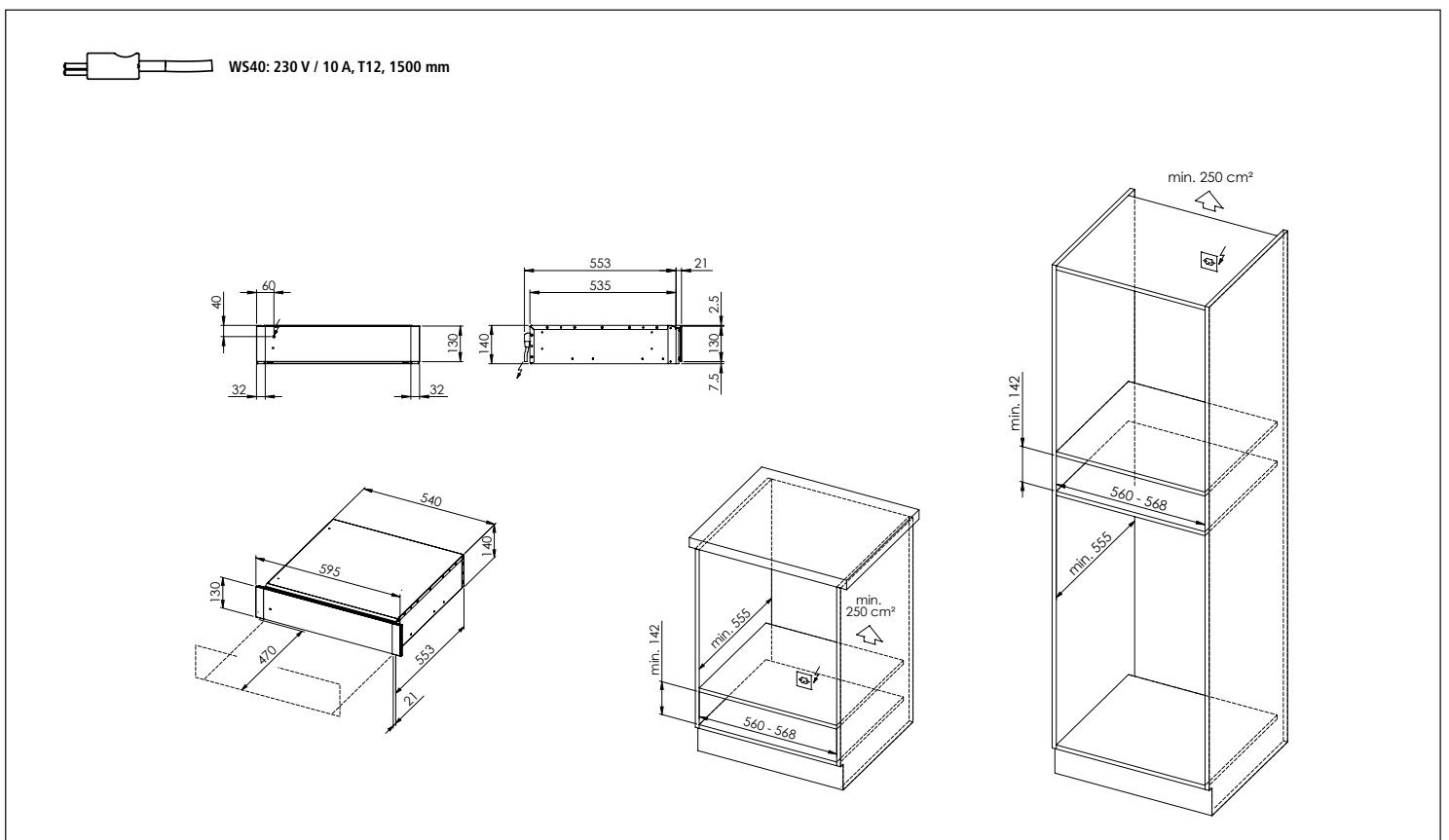

Samsung Backöfen und Kompaktgeräte: Masszeichnungen

Forni e apparecchi compatti Samsung: disegni quotati

Samsung BO und BO
 Samsung BO e BO

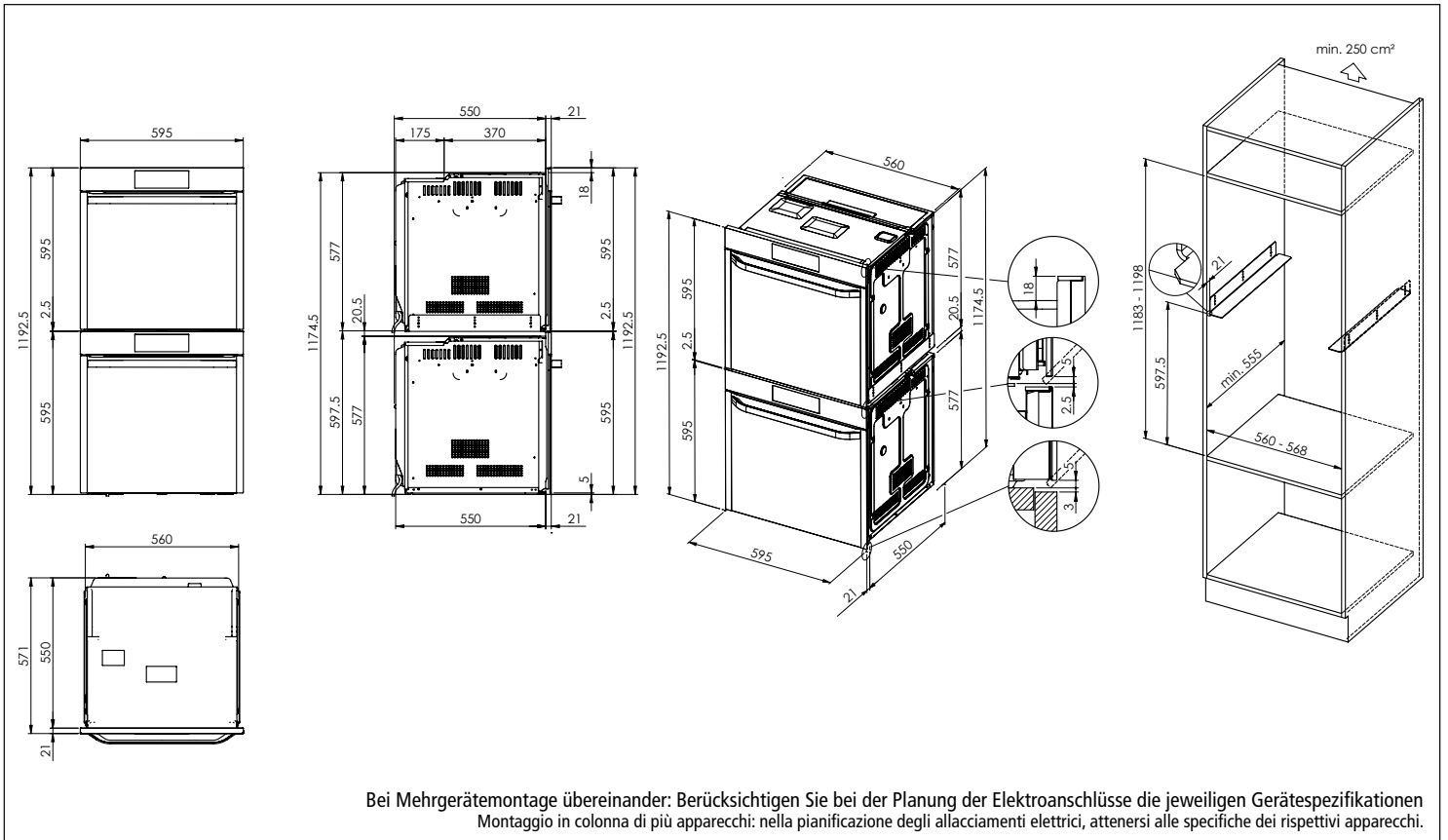

Samsung WS und BO und BO
 Samsung WS e BO e BO

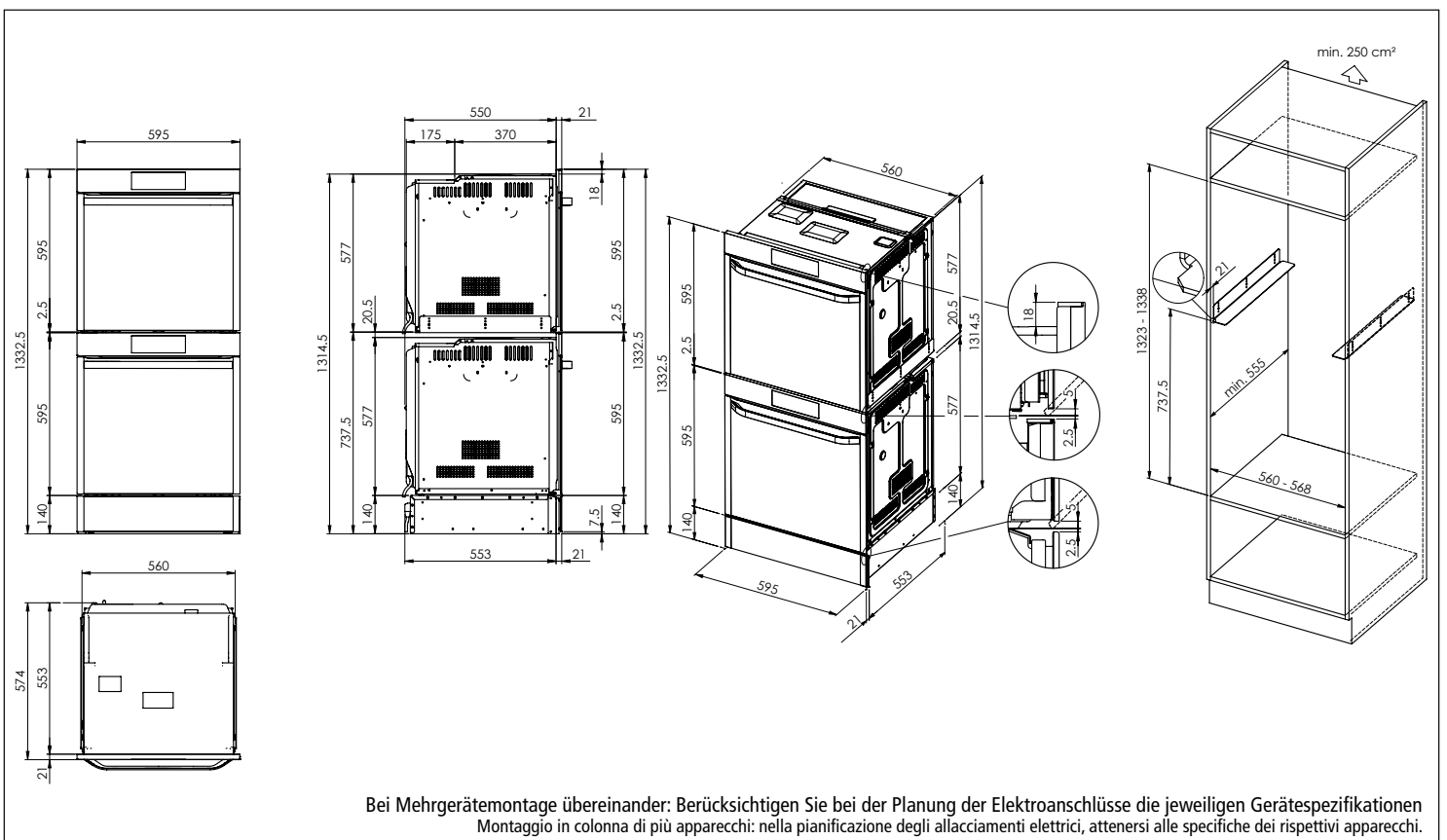

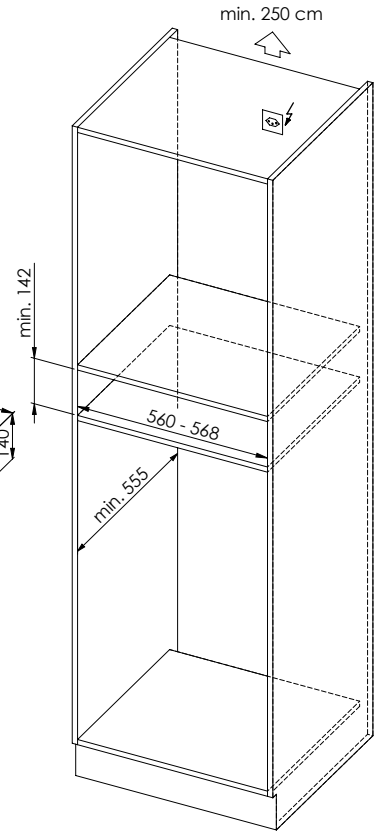
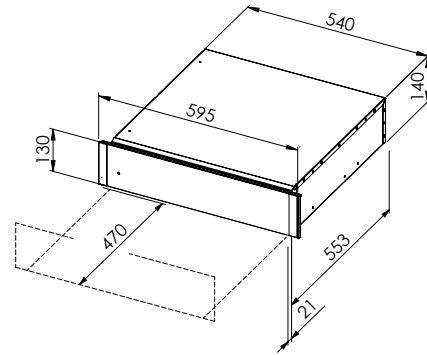
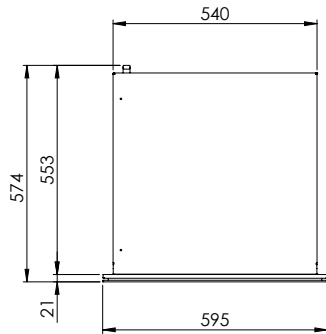
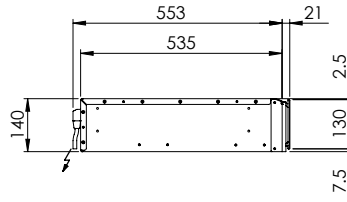
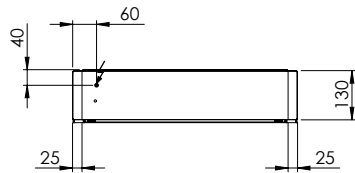

WS10/20/30/50: 230 V / 10 A, T12, 1500 mm

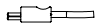
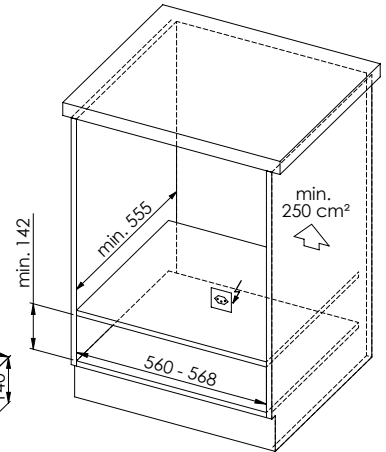
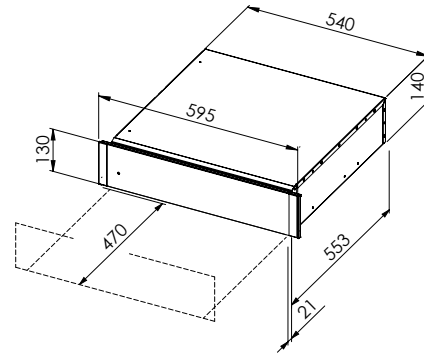
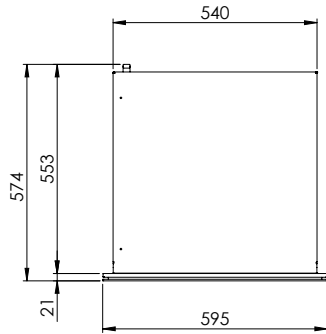
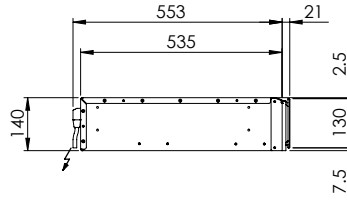
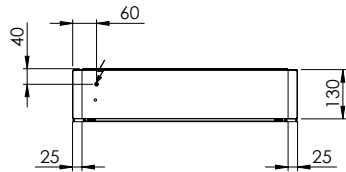

WS10/20/30/50: 230 V / 10 A, T12, 1500 mm

Für diese Zeichnung sind alle Rechte vorbehalten. Nachdruck, Vervielfältigung und Verbreitung, auch auszugsweise, ist ohne schriftliche Genehmigung der Suter Inox AG. Alle Rechte vorbehalten.
 This drawing and its content are the property of Suter Inox AG. All rights reserved. Any reproduction, copying or distribution, even in part, without written permission is prohibited. © Copyright 2003 Suter Inox AG. All rights reserved.

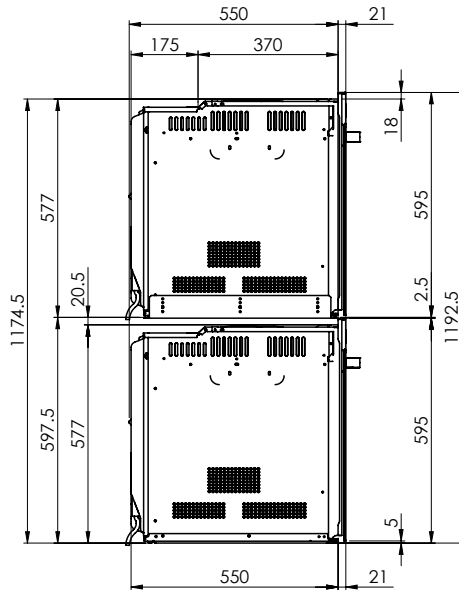
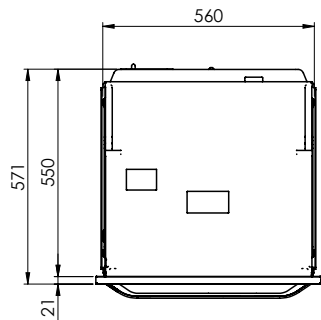
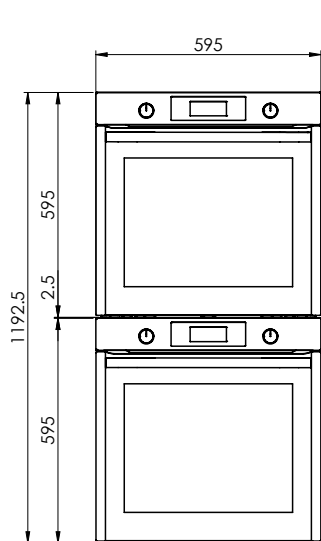

Bei Mehrgerätemontage übereinander: Berücksichtigen Sie bei der Planung der Elektroanschlüsse die jeweiligen Gerätespezifikationen.
 Montage de plusieurs appareils l'un sur l'autre: veuillez tenir compte des spécifications de chaque appareil lors de la planification des raccordements électriques.
 Montaggio in colonna di più apparecchi: nella pianificazione degli allacciamenti elettrici, attenersi alle specifiche dei rispettivi apparecchi.

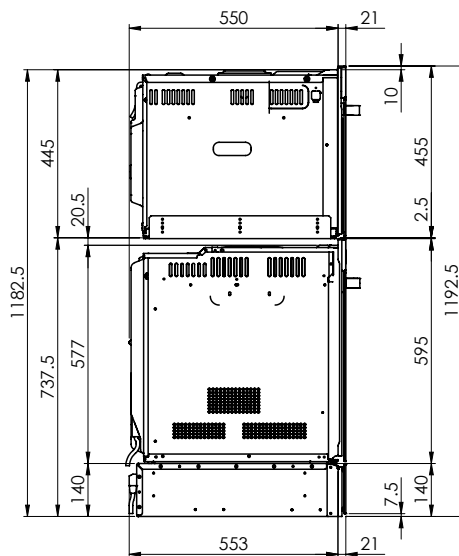
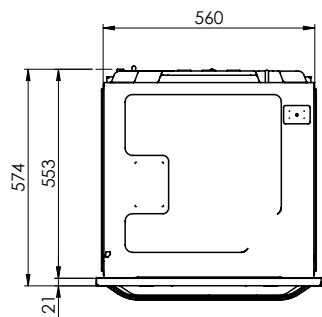
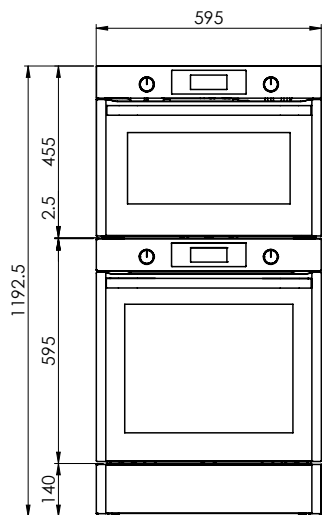

Bei Mehrgerätemontage übereinander: Berücksichtigen Sie bei der Planung der Elektroanschlüsse die jeweiligen Gerätespezifikationen.
 Montage de plusieurs appareils l'un sur l'autre: veuillez tenir compte des spécifications de chaque appareil lors de la planification des raccordements électriques.
 Montaggio in colonna di più apparecchi: nella pianificazione degli allacciamenti elettrici, attenersi alle specifiche dei rispettivi apparecchi.

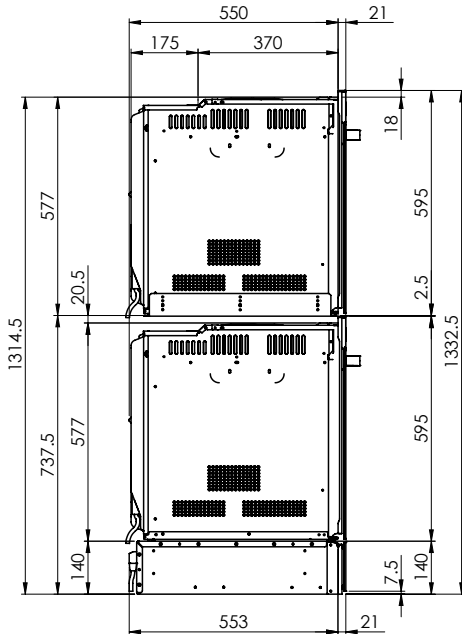
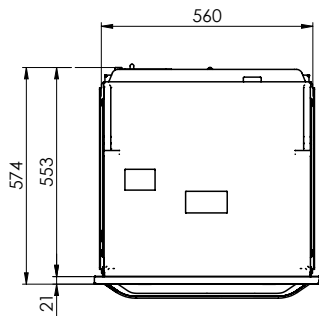
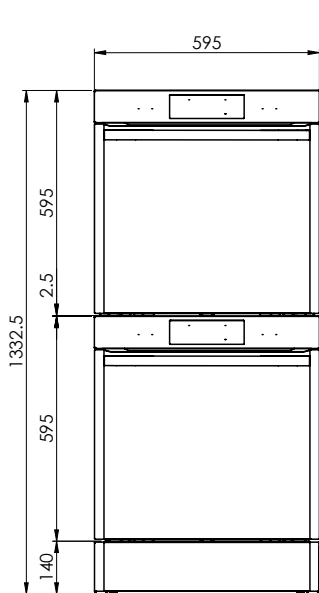

Bei Mehrgerätemontage übereinander: Berücksichtigen Sie bei der Planung der Elektroanschlüsse die jeweiligen Gerätespezifikationen.
 Montage de plusieurs appareils l'un sur l'autre: veuillez tenir compte des spécifications de chaque appareil lors de la planification des raccordements électriques.
 Montaggio in colonna di più apparecchi: nella pianificazione degli allacciamenti elettrici, attenersi alle specifiche dei rispettivi apparecchi.

