

Daneo DAN 100-55IF

> Weblink

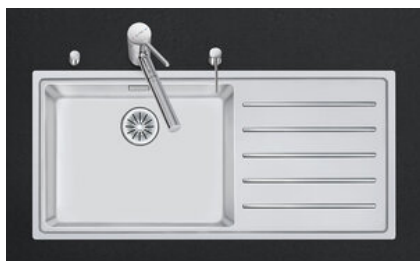

Montaggio
Lavelli a filo top / Lavelli sopra piano

Modello
DAN 100-55IF

Materiale
Acciaio inox 18/10

N. di articolo
10.103.986.00

Dimensioni base
60 cm

Piletta
3½" Salvaspazio

Finitura
Opaco

Prezzo in CHF
2'198.- IVA esclusa

Dimensioni lavello
550x400x188mm

Raggi d'angolo
22 mm

Scolatoio
Destra

Tecnologia di scarico e troppopieno



Griglietta - tipo S



Placchetta di troppopieno a ribalta

Premontaggio della piletta

Montaggio della piletta in fabbrica

Distributore - opzioni di montaggio

Posizione a scelta

Tecnologia di scarico e troppopieno

Pomolo inclusi



Advant

Prezzi (aggiornati al 21.06.26 / IVA esclusa)

Modello	Materiale	Piletta	Scolatoio	N. di articolo	Prezzo in CHF	
Daneo DAN 100-55IF	Acciaio inox 18/10, Opaco	3½" Tipo	Sinistra	10.103.976.00	2'157.-	> Weblink
		3½" Tipo	Destra	10.103.977.00	2'157.-	> Weblink
		3½" Salvaspazio	Sinistra	10.103.985.00	2'198.-	> Weblink
		3½" Salvaspazio	Destra	10.103.986.00	2'198.-	> Weblink
		3½" TouchFlow	Sinistra	10.103.974.00	2'396.-	> Weblink
		3½" TouchFlow	Destra	10.103.975.00	2'396.-	> Weblink

Descrizione del prodotto

1 versione di prodotto, 2 metodi di montaggio

I modelli IF presentano un grande vantaggio: possono essere posati sia a filo top che sopra piano.

Montaggio a filo top: Consiglio per la scelta del piano di lavoro

Consigliamo il montaggio nei piani di lavoro in ceramica, granito, pietra artificiale (per es. Corian o Varicor) oppure in legno massiccio. Sconsigliamo la posa in pannelli di truciolato rivestiti.

Accessorio

Accessori opzionali



> Weblink
40.000.912.00 / CHF
106.-
Vaschetta, forato



> Weblink
40.001.289.00 / CHF
106.-
Vaschetta, non forato

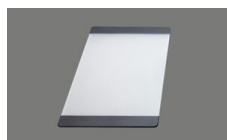

> Weblink
40.000.909.00 / CHF
151.-
Tagliere, in vetro, bianco

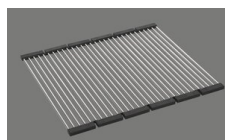

> Weblink
40.001.140.00 / CHF
125.-
Inox Pad

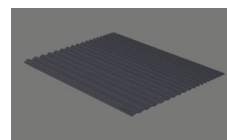

> Weblink
40.002.008.00 / CHF 51.-
Maro tappetino
scolapiatti, Dark Grey

Ricambi

Qui trovate tutti gli accessori compatibili > Weblink

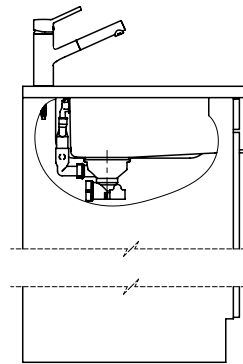
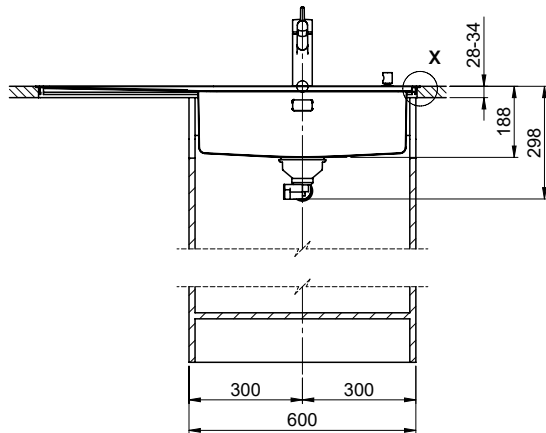
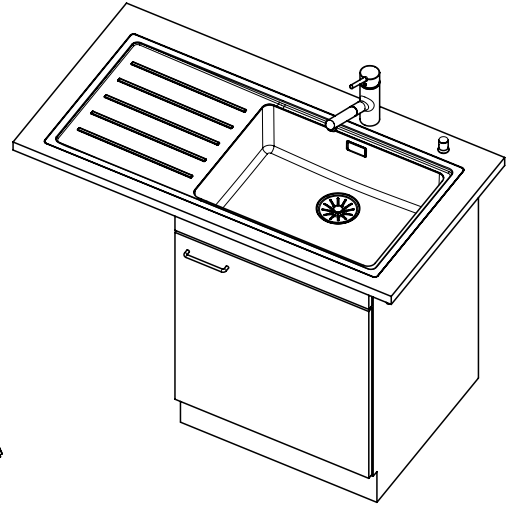
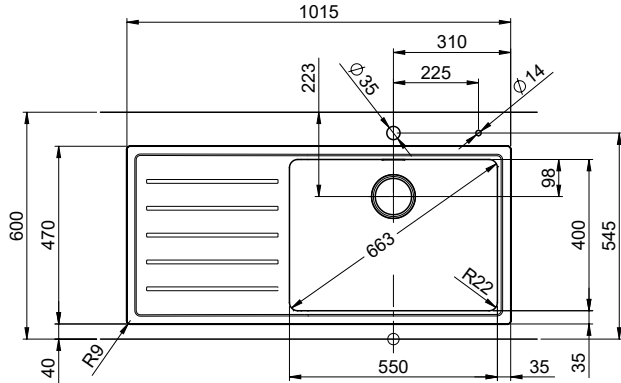

Daneo DAN 100-55IF sFlow Typ S, Tropfteil links
 Daneo DAN 100-55IF sFlow Typ S, égouttoir à gauche
 Daneo DAN 100-55IF sFlow Typ S, scolatoio a sinistra

Bohrung für Zug- und Druckknöpfe ø14
 Bohrung für Drehknopf ø25

Trou pour boutons et Pousoirs de commande ø14
 Trou pour bouton rotatif ø25

Foro per Pomelli tiranti e Pomelli pulsanti ø14
 Foro per Pomolo girevoli ø25

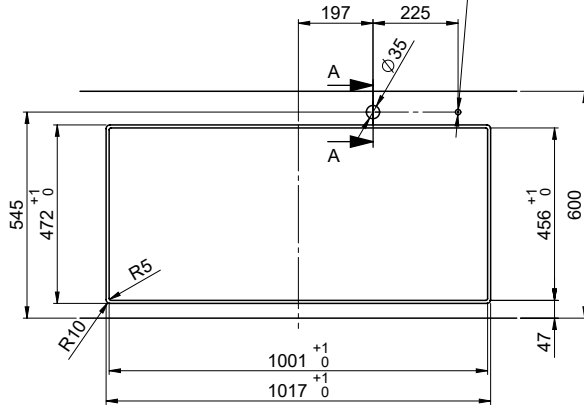

A-A (1 : 2)

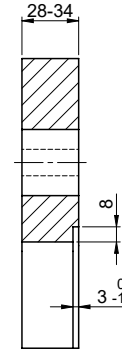

X (1:1)

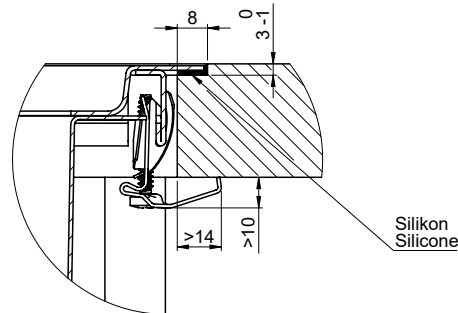

Vom flächenbündigen Einbau in beschichteten Spanplatten raten wir ab.

Nous vous déconseillons le montage à fleur sur des panneaux de particules enduits.

Sconsigliamo il montaggio a filo top in pannelli di truciolato laminato.

Daneo DAN 100-55IF sFlow Typ S, Tropfteil links
 Daneo DAN 100-55IF sFlow Typ S, égouttoir à gauche
 Daneo DAN 100-55IF sFlow Typ S, scolatoio a sinistra

Bohrung für Zug- und Druckknöpfe ø14
 Bohrung für Drehknopf ø25

Trou pour boutons et Pousoirs de commande ø14
 Trou pour bouton rotatif ø25

Foro per Pomelli tiranti e Pomelli pulsanti ø14
 Foro per Pomolo girevoli ø25

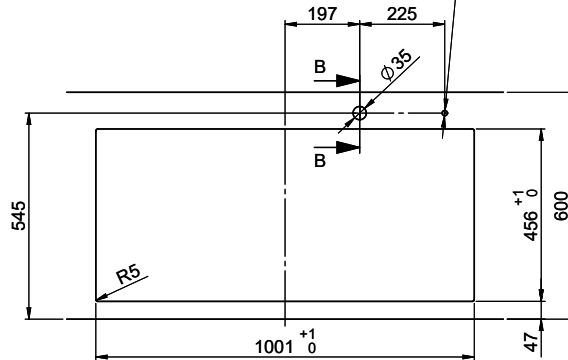

B-B (1 : 2)



X (1:1)

