

Daneo DAN 40F/7

> Weblink



Montaggio
Lavelli a filo top
Modello
DAN 40F/7
Materiale
Acciaio inox 18/10
N. di articolo
10.105.704.00

Dimensioni base
45 cm
Piletta
3½" Tipo Desino
Finitura
Opaco
Prezzo in CHF
1'399.- IVA esclusa

Dimensioni lavello
400x400x175mm
Raggi d'angolo
22 mm

Tecnologia di scarico e troppopieno



Tipo Desino: Scarico coperto con griglietta inferiore - tipo M



Placchetta di troppopieno a ribalta

Premontaggio della piletta

Premontaggio della piletta in fabbrica

Distributore - opzioni di montaggio

Posizione a scelta

Tecnologia di scarico e troppopieno

Prezzi (aggiornati al 21.06.26 / IVA esclusa)

Modello	Materiale	Piletta	N. di articolo	Prezzo in CHF	
Daneo DAN 40F/7	Acciaio inox 18/10, Opaco	3½" Tipo Desino	10.105.704.00	1'399.-	> Weblink
		3½" Salvaspazio Desino	10.104.648.00	1'399.-	> Weblink
		3½" TouchFlow Desino	10.104.647.00	1'609.-	> Weblink
		3½" eFlow Desino	10.104.672.00	1'724.-	> Weblink

Descrizione del prodotto

Disponibile solo per montaggio a filo top.

Montaggio a filo top: Consiglio per la scelta del piano di lavoro

Consigliamo il montaggio nei piani di lavoro in ceramica, granito, pietra artificiale (per es. Corian o Varicor) oppure in legno massiccio. Sconsigliamo la posa in pannelli di truciolato rivestiti.

Pulizia

La griglietta per lo scarico Desino è lavabile in lavastoviglie e può essere pulita completamente o separatamente fino a una temperatura massima di 65 °C.

Accessorio

Accessori opzionali



> Weblink
40.000.912.00 / CHF 106.-
Vaschetta, forato



> Weblink
40.001.289.00 / CHF 106.-
Vaschetta, non forato



> Weblink
40.000.909.00 / CHF 151.-
Tagliere, in vetro, bianco



> Weblink
40.001.277.00 / CHF 151.-
Tagliere, sintetico

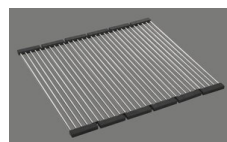

> Weblink
40.001.138.00 / CHF 125.-
Inox Pad

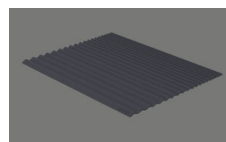

> Weblink
40.002.008.00 / CHF 51.-
Maro tappetino scolapiatti, Dark Grey

Daneo DAN 40F7 [> Weblink](#)

Ricambi

Qui trovate tutti gli accessori compatibili [> Weblink](#)

Daneo DAN 40F/7 Desino

Randbreite 7mm
Bord de 7mm de largeur
Larghezza bordo 7mm

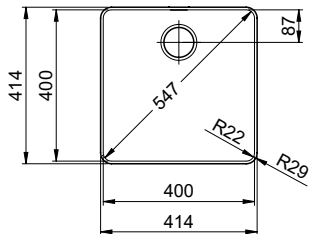

Für 12mm Arbeitsplatte.
 Pour plan de travail de 12mm.
 Per piano di lavoro da 12mm.

X (1 : 2)

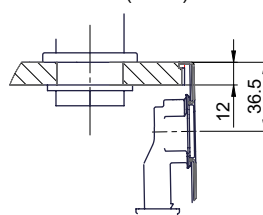

Y (1 : 2)

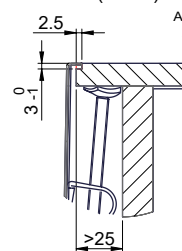

Silikonieren
 Appliquer du silicone
 Applicare il silicone

Traverse
 Transversale
 Traversa

Für 13 - 30mm Arbeitsplatte.
 Pour plan de travail de 13 - 30mm.
 Per piano di lavoro da 13 - 30mm.

X (1 : 2)

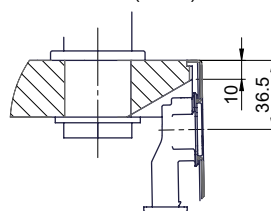

Y (1 : 2)

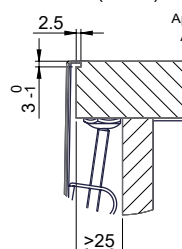

Silikonieren
 Appliquer du silicone
 Applicare il silicone

Traverse
 Transversale
 Traversa

Für 13 - 50mm Arbeitsplatte.
 Pour plan de travail de 13 - 50mm.
 Per piano di lavoro da 13 - 50mm.

X (1 : 2)

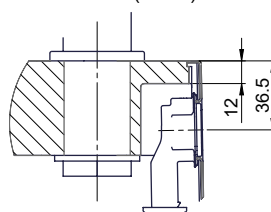

Y (1 : 2)

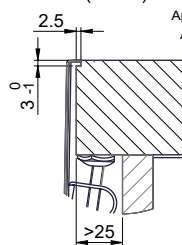

Silikonieren
 Appliquer du silicone
 Applicare il silicone

Traverse
 Transversale
 Traversa

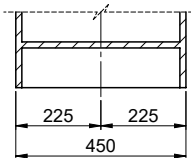
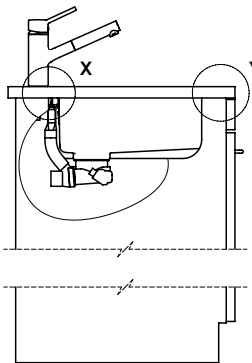
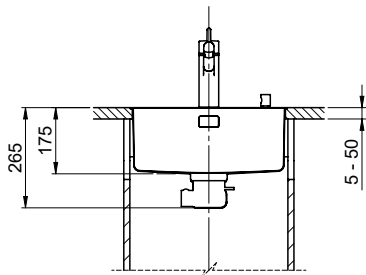

Bei der Planung die Traverse im Möbel beachten!

Faites attention à la barre transversale dans les meubles lors de la planification!

Presta attenzione alla traversa nei mobili durante la pianificazione!

Vom flächenbündigen Einbau in beschichteten Spanplatten raten wir ab.

Nous vous déconseillons le montage à fleur sur des panneaux de particules enduits.

Sconsigliamo il montaggio a filo top in pannelli di truciolato laminato.

Daneo DAN 40F/7 Desino

Ausschnitt für flächenbündigen Einbau - Randbreite 7mm:
 Mesure de coupe pour montage à fleur - Bord de 7mm de largeur:
 Intaglio per montaggio a filo top - Larghezza bordo 7mm:

Bohrung für Zug- und Druckknöpfe ø14
 Bohrung für Drehknopf ø25

Trou pour boutons et Pousoirs de commande ø14
 Trou pour bouton rotatif ø25

Foro per Pomelli tiranti e Pomelli pulsanti ø14
 Foro per Pomolo girevoli ø25

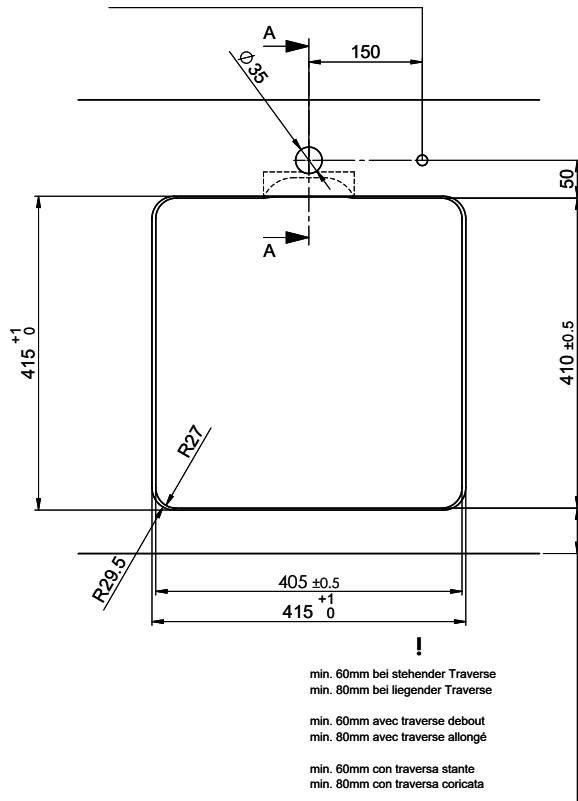

Für 12mm Arbeitsplatte.
 Pour plan de travail de 12 mm.
 Per piano di lavoro da 12 mm.

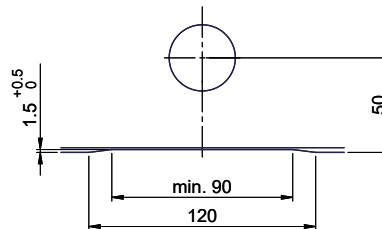

A-A (1 : 2)

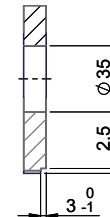

Für 13 - 30mm Arbeitsplatte.
 Pour plan de travail de 13 - 30mm.
 Per piano di lavoro da 13 - 30mm.

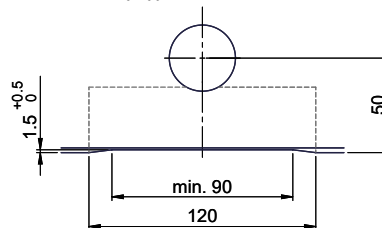

A-A (1 : 2)

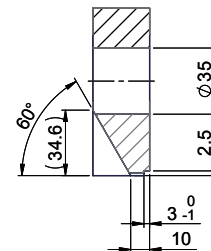

Für 13 - 50mm Arbeitsplatte.
 Pour plan de travail de 13 - 50mm.
 Per piano di lavoro da 13 - 50mm.

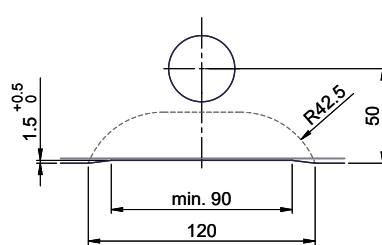

A-A (1 : 2)

