

Daneo DAN 50IF/A

[> Weblink](#)

Dimensioni base 55 cm

**Montaggio**

Lavelli a filo top / Lavelli sopraiano

Modello

DAN 50IF/A

Materiale

Acciaio inox 18/10

N. di articolo

10.103.586.00

Dimensioni base

55 cm

Piletta

3½" TouchFlow

Finitura

Opaco

TRA

0.19

Prezzo in CHF

1'676.- IVA esclusa

Dimensioni lavello

500x400x176mm

Raggi d'angolo

22 mm

Tecnologia di scarico e troppopieno

Griglietta - tipo S



Placchetta di troppopieno a ribalta TouchFlow

Premontaggio della piletta

Montaggio della piletta in fabbrica

Distributore - opzioni di montaggio

Tutti i modelli

Tecnologia di scarico e troppopieno**Pomolo inclusi****Prezzi (aggiornati al 09.05.26 / IVA esclusa)**

Modello	Materiale	Piletta	N. di articolo	Prezzo in CHF	
Daneo DAN 50IF/A	Acciaio inox 18/10, Opaco	3½" Tipo	10.103.587.00	1'437.-	> Weblink
		3½" TouchFlow	10.103.586.00	1'676.-	> Weblink

Descrizione del prodotto**1 versione di prodotto, 2 metodi di montaggio**

I modelli IF presentano un grande vantaggio: possono essere posati sia a filo top che sopraiano.

Montaggio a filo top: Consiglio per la scelta del piano di lavoro

Consigliamo il montaggio nei piani di lavoro in ceramica, granito, pietra artificiale (per es. Corian o Varicor) oppure in legno massiccio. Sconsigliamo la posa in pannelli di truciolato rivestiti.

Accessorio

Accessori opzionali



[> Weblink](#)
40.000.912.00 / CHF
106.-
Vaschetta, forato



[> Weblink](#)
40.001.289.00 / CHF
106.-
Vaschetta, non forato

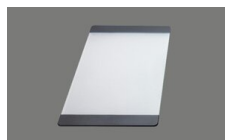

[> Weblink](#)
40.000.909.00 / CHF
151.-
Tagliere, in vetro, bianco



[> Weblink](#)
40.001.277.00 / CHF
151.-
Tagliere, sintetico

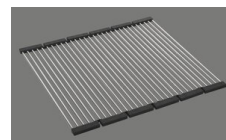

[> Weblink](#)
40.001.138.00 / CHF
125.-
Inox Pad

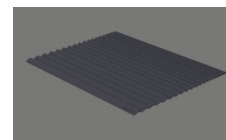

[> Weblink](#)
40.002.008.00 / CHF 51.-
Maro tappetino
scolapiatti, Dark Grey

RicambiQui trovate tutti gli accessori compatibili [> Weblink](#)

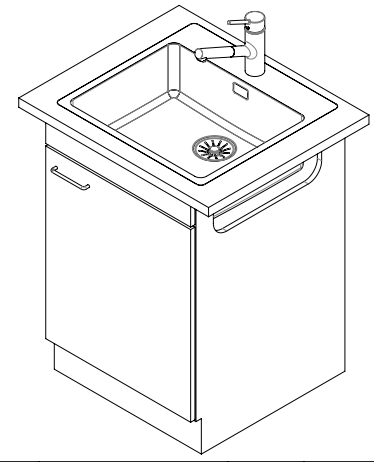
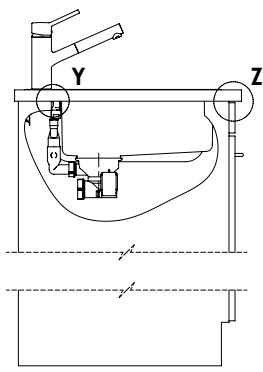
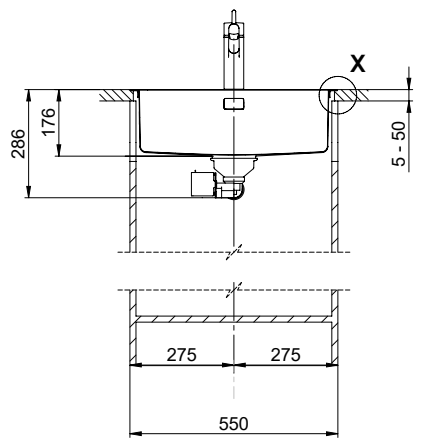
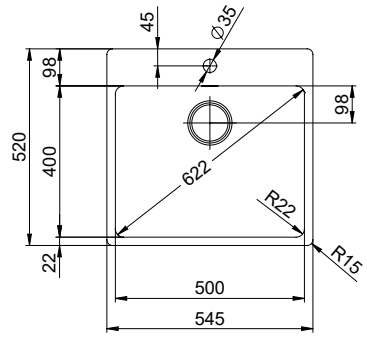

Für dieses Dokument und den darin dargestellten Gegenstand behalten wir uns alle Rechte vor. Verwendung, Beibehaltung an
 anderen Stellen, Vervielfältigung, Verbreitung, auch auszugsweise, ist ohne schriftliche Genehmigung der Suter AG. Copyright 2020 Suter AG. All rights reserved.

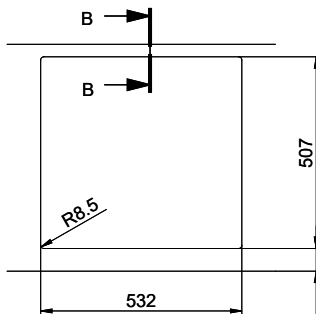

B-B (1 : 2)



60mm bei stehender Traverse
 80mm bei liegender Traverse
 60mm con traversa coricata
 80mm con traversa stante
 60mm avec traverse allongé
 80mm avec traverse debout

X (1:1)

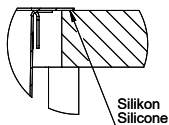

Y (1:1)

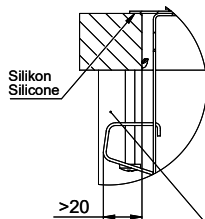

Achtung: Traverse vorne und hinten beachten!
 Attention: respecter la traverse arrière et avant!
 Attenzione: rispettare la traversa avanti e dietro!

Z (1:1)

