

## Samsung Forno BO20 Dual Door (Dual Cook Flex)

[> Weblink](#)

**Modello**  
Samsung Forno BO20 Dual Door (Dual Cook Flex)

**Classe di efficienza energetica**  
A+

**N. del produttore**  
NV75N7677RS/EU

**N. di articolo**  
500.000.001.00

**Tipo di apparecchio**  
Forni

**Versione costruttiva**  
Norma Euro 60 cm

**TRA**  
10.00

**Prezzo in CHF**  
880.- IVA esclusa

## Highlights

- Volume vano cottura di 75 litri - eccezionale spaziosità
- 50 programmi automatici
- Dual Cook - preparazione contemporanea di due piatti diversi
- Pratico: WiFi Smart Control da smartphone e app
- Dual Door Flex™ - maggiore flessibilità nella cottura al forno
- Autopulente: pirolisi e vapore
- Vano cottura in smalto ceramico: antigraffio, antibatterico
- Facilità d'uso: manopola a scomparsa e tasti a sensore

## Descrizione del prodotto

Versione costruttiva: **Euro-Norm 60 cm**  
GTIN-Nr.: **881643182809**

## Efficienza e consumi

Classe di efficienza energetica (da A+++ a D): **A+**  
Indice di efficienza energetica: **81,6**

## Consumo energetico

Consumo energetico, convenzionale (kWh / ciclo): **1.05 kWh**  
Consumo energetico aria di ricircolo / aria calda (kWh / ciclo): **0,71 kWh**  
Consumo in standby: **0,9 W**  
Consumo autopulizia pirolitica (kWh / ciclo): **-5.0 kWh**

## Design

Colore pannello di comando: **Nero**  
Materiale pannello di comando: **Vetro**  
Telaio / materiale: **Si / acciaio inox**

## Indicatore e pannello di comando

Indicatore: **Indicatore digitale**  
Display e illuminazione: **LED, azzurro ghiaccio**  
Pannello di comando: **Manopola a scomparsa, tasti a sensore, WiFi, Dual Door Flex™**

## Interconnessione domestica

Samsung Smart Home: **WiFi Smart Control**

## Proprietà funzionali

Temperatura max regolabile per riscaldamento superiore/inferiore, aria di ricircolo/aria calda: **275°C**  
Temperatura per funzionamento a vapore:-  
Potenza di uscita microonde: -  
Superficie utile griglia: **1906 cm2**  
Volume utile vano cottura: **75 L**

## Dimensioni

Altezza: **59,5 cm**  
Larghezza: **59 cm**  
Profondità: **54.9 cm**  
Profondità (dal frontale del mobile) : **56.6 cm**  
Profondità con porta aperta (davanti al frontale del mobile) : **49.4 cm**  
Dimensioni apparecchio (A x L x P): **595 x 590 x 549 mm**

## Peso a vuoto

Peso dell'apparecchio: **47,2 kg**

## Funzioni e dotazioni

Misure interne (dimensioni utili) in cm (altezza / larghezza / profondità): **375 x 465 x 397 mm**  
Riscaldamento superiore e inferiore: **Si / si**  
Aria di ricircolo: -

**Samsung Forno BO20 Dual Door (Dual Cook Flex)**[> Weblink](#)

Aria calda: **Si / si**  
 Vapore: -  
 Microonde: -  
 Ausilio per pulizia catalitica: -  
 Ausilio per pulizia pirolitica: **Si**  
 Elemento riscaldante grill integrabile: **Si / -**  
 Motore grill / griglie di ventilazione: **Si**  
 Timer / interruttore a tempo: **Si**  
 Cassetto / cassetto scaldavivande: - / **opzionale**  
 Numero di vani cottura: **3**  
 Volume di ciascun vano di cottura  
 Funzionamento normale / vano cottura superiore / vano cottura inferiore: **75 L / 34 L / 32 L**  
 Numero di ripiani: **5**  
 Illuminazione / finestra: **Si / si**  
 Lamadina: **2 x 40 W, alogena**  
 Guide telescopiche estraibili: **1 livello**  
 Pulizia: **Pirolisi, pulizia a vapore**  
 Metodo di raffreddamento: **Ventola di raffreddamento**  
 Rivestimento interno: **Smalto ceramico**

**Modi di cottura**

Vapore: -  
 Vapore + riscaldamento: -  
 Vapore + aria calda: -  
 Vapore + riscaldamento sup. + aria calda: -  
 Vapore + riscaldamento inf. + aria calda: -  
 Riscaldamento sup./inf.: **30~275°C**  
 Aria calda **30~275°C**  
 Aria calda ECO: **30~275°C**  
 Grill: grande / Eco / ricircolo: **100~300°C / 100~300°C / -**  
 Riscaldamento inf. + aria calda: **40~275°C**  
 Riscaldamento sup. + aria calda: **40~275°C**  
 Riscaldamento inferiore: **100~230°C**  
 Cottura intensiva: -  
 Arrosto automatico (ProRoasting): **80~200°C**  
 Microonde + grill: -  
 Microonde + aria calda: -

**Programmi**

Funzioni speciali: **Scaldavivande, scaldastoviglie, riscaldamento rapido**  
 Programmi automatici: **50**  
 Dual Cook: **Si**

**Funzioni di controllo**

Funzioni di controllo: **Orologio, timer, sicurezza bambini, tempi di cottura, fine cottura, avvio differito, segnale acustico**

**Potenza assorbita**

Potenza totale: **3600-3950 W**  
 Aria calda **1200 W**  
 Riscaldamento sup.: **1600 / 1100 W**  
 Riscaldamento inf.: **1100 W**  
 Grill: **1600 / 1100 W**  
 Griglia piana (grande): **1600 W**

**Allacciamento elettrico**

Tensione di attacco: **230 V**  
 Frequenza: **50 Hz**  
 Potenza allacciata: **3,65-3,95 kWh**  
 Protezione: **16 A**  
 Lunghezza cavo di allacciamento: - / **Cavo di allacciamento da mettere a disposizione in loco**  
 Connettore di alimentazione: - / **Collegamento diretto**

**Dati tecnici**

Standard di larghezza: **Norma Euro 60 cm**  
 Standard di altezza: **Norma Euro 60 cm**  
 Altezza di nicchia: **590 mm - 600 mm**  
 Larghezza di nicchia: **min. 560 mm**  
 Profondità di nicchia: **min. 550 mm**  
 Misure di nicchia (A x L x P) : **min. 590-600 x 560 x 550 mm**  
 Larghezza apparecchio in mm: **590 mm**  
 Altezza apparecchio in mm: **595 mm**  
 Altezza apparecchio in mm: **549 mm**

**Imballaggio**

Peso, imballaggio incluso: **50 kg**  
 Misure imballaggio (A x L x P) **656 x 682 x 645 mm**

**Samsung Forno BO20 Dual Door (Dual Cook Flex)**[> Weblink](#)**Accessorio**

## Accessori incluso



> Weblink  
500.000.046.00 / CHF  
880.-  
Divisorio per vano cottura

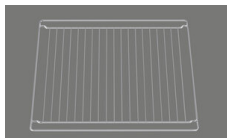

> Weblink  
500.000.042.00 / CHF  
880.-  
Graticola

## Accessori opzionali



> Weblink  
500.000.040.00 / CHF  
88.-  
Teglia extra profonda 50  
mm

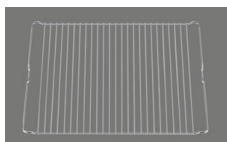

> Weblink  
500.000.045.00 / CHF  
49.-  
Insero per griglia



> Weblink  
500.000.074.00 / CHF  
60.-  
Set di squadrette di  
supporto

**Prodotti compatibili**

> Weblink  
500.000.009.00 / CHF  
350.-  
Cassetto scaldavivande  
WS10/20/30/50

# Samsung Backöfen und Kompaktgeräte: Masszeichnungen Forni e apparecchi compatti Samsung: disegni quotati

## Samsung Backofen BO10 Gourmet Vapour Forno Samsung BO10 Gourmet Vapour

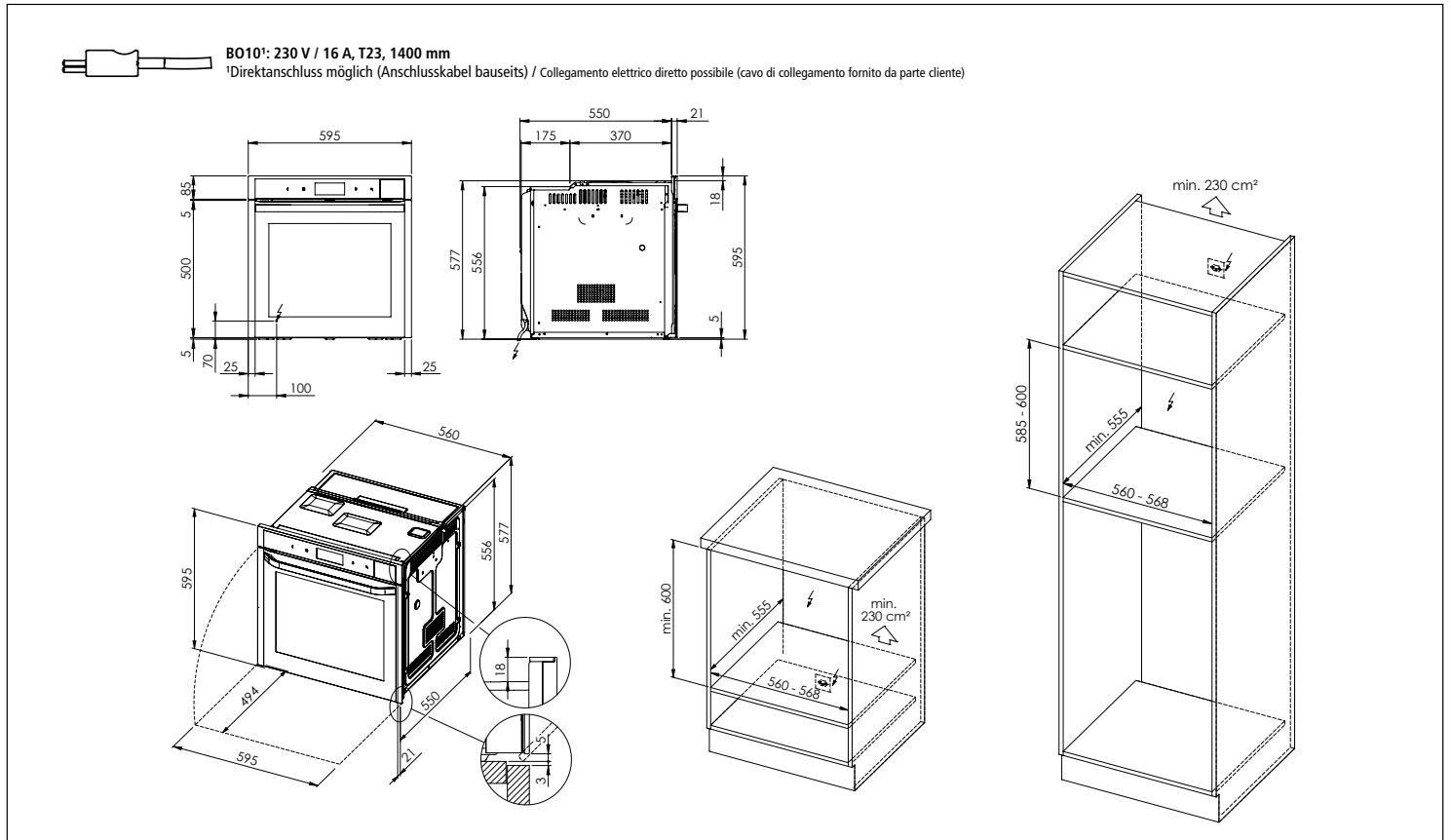

## Samsung Backofen BO10 Gourmet Vapour mit Wärmeschublade WS10/20/30/50 Forno Samsung BO10 Gourmet Vapour con cassetto scaldavivande WS10/20/30/50

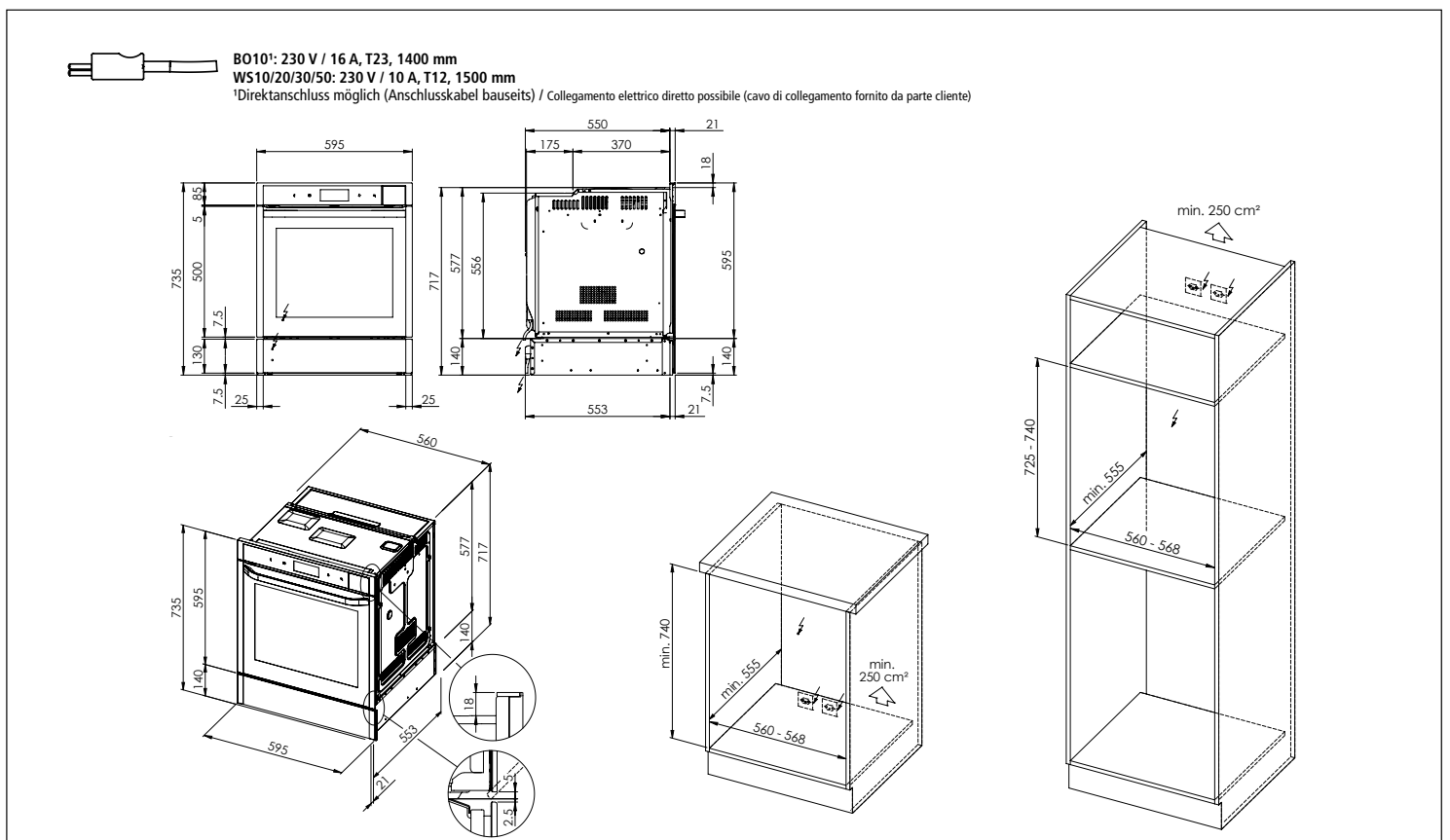

# Samsung Backöfen und Kompaktgeräte: Masszeichnungen

## Forni e apparecchi compatti Samsung: disegni quotati

### Samsung Backofen BO20 Dual Door Forno Samsung BO20 Dual Door

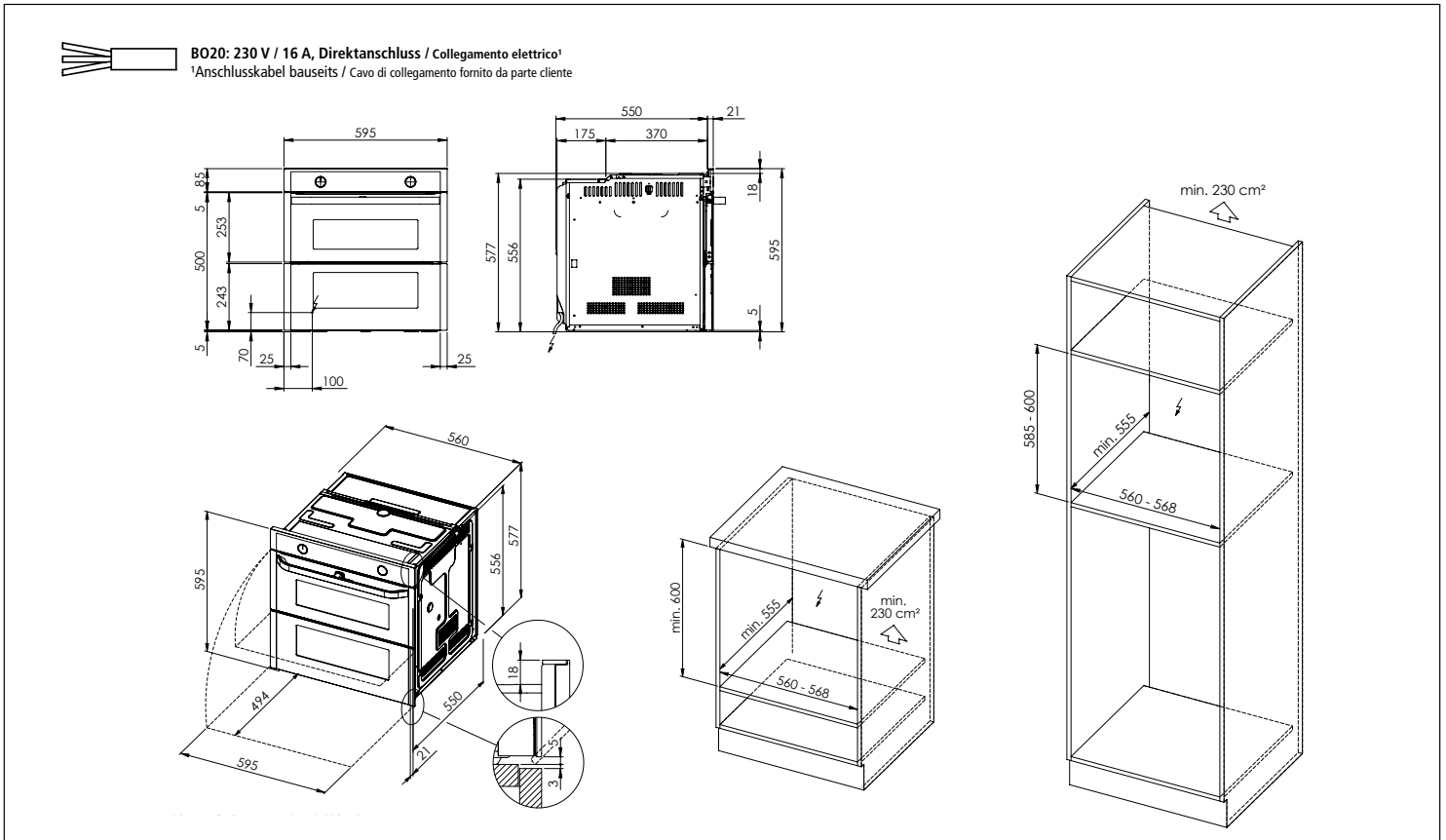

### Samsung Backofen BO20 Dual Door mit Wärmeschublade WS10/20/30/50 Forno Samsung BO20 Dual Door con cassetto scaldavivande WS10/20/30/50

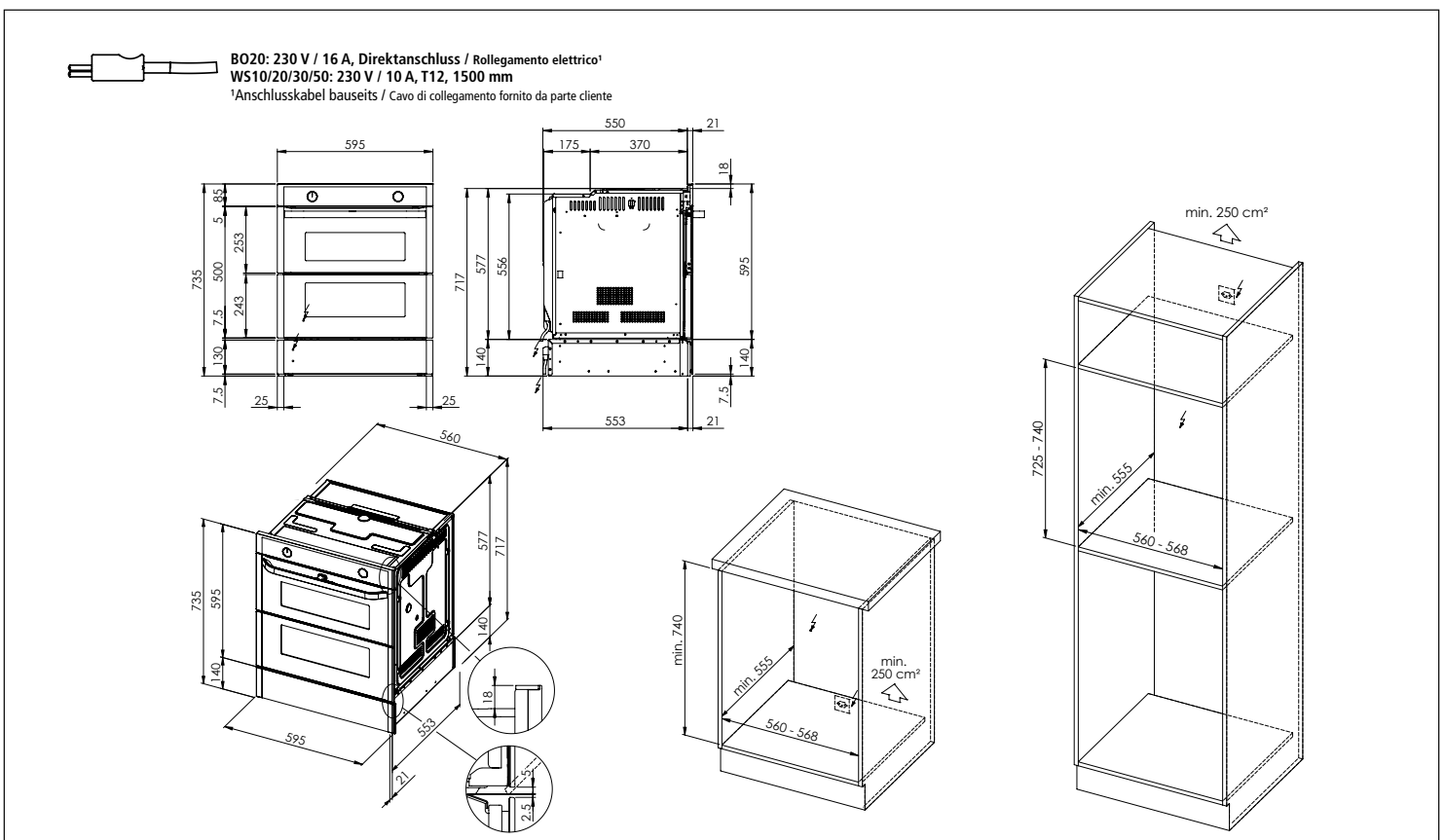

# Samsung Backöfen und Kompaktgeräte: Masszeichnungen Forni e apparecchi compatti Samsung: disegni quotati

## Samsung Backofen BO30 Dual Door Forno Samsung BO30 Dual Door

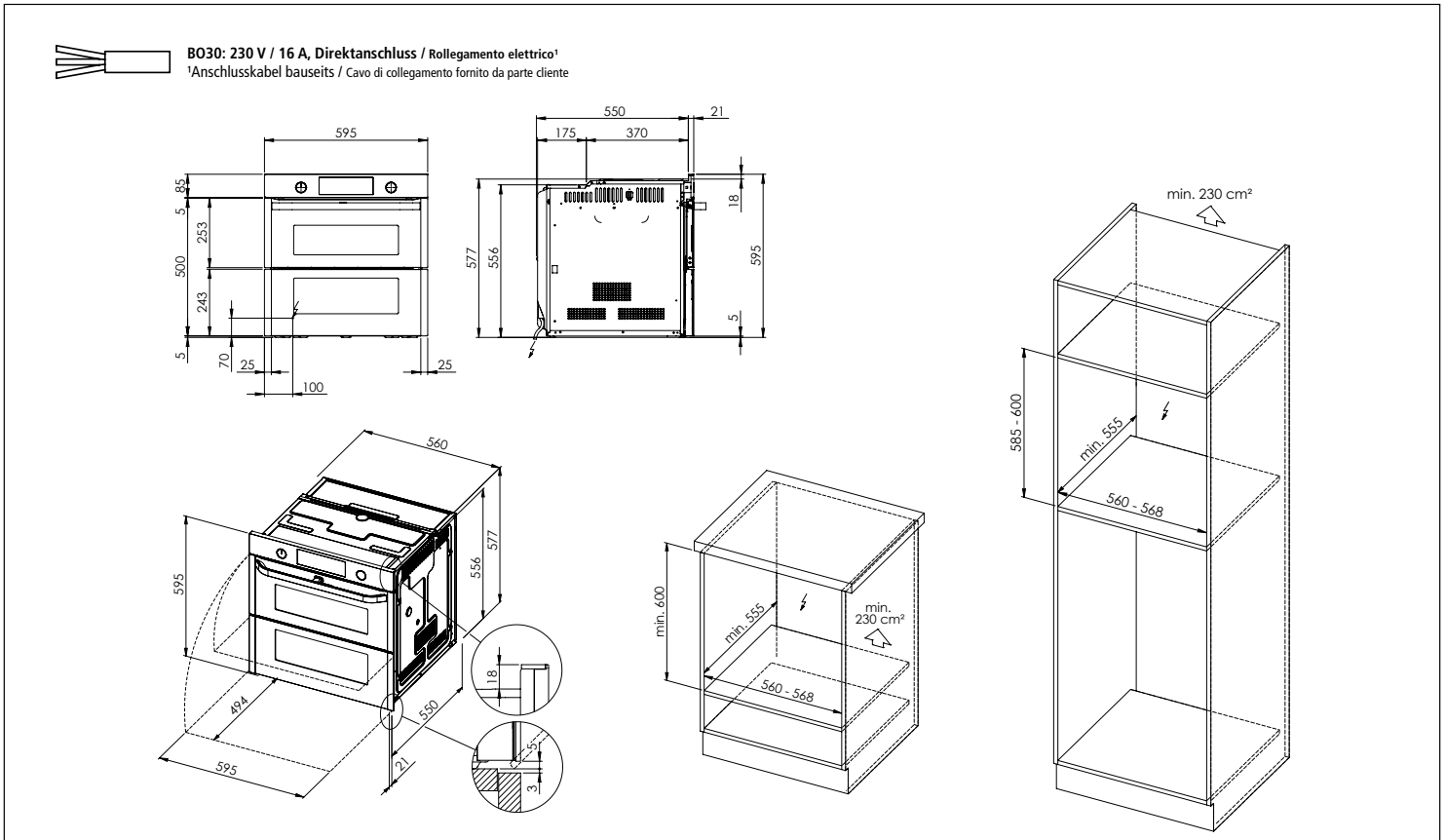

## Samsung Backofen BO30 Dual Door mit Wärmeschublade WS10/20/30/50 Forno Samsung BO30 Dual Door con cassetto scaldavivande WS10/20/30/50

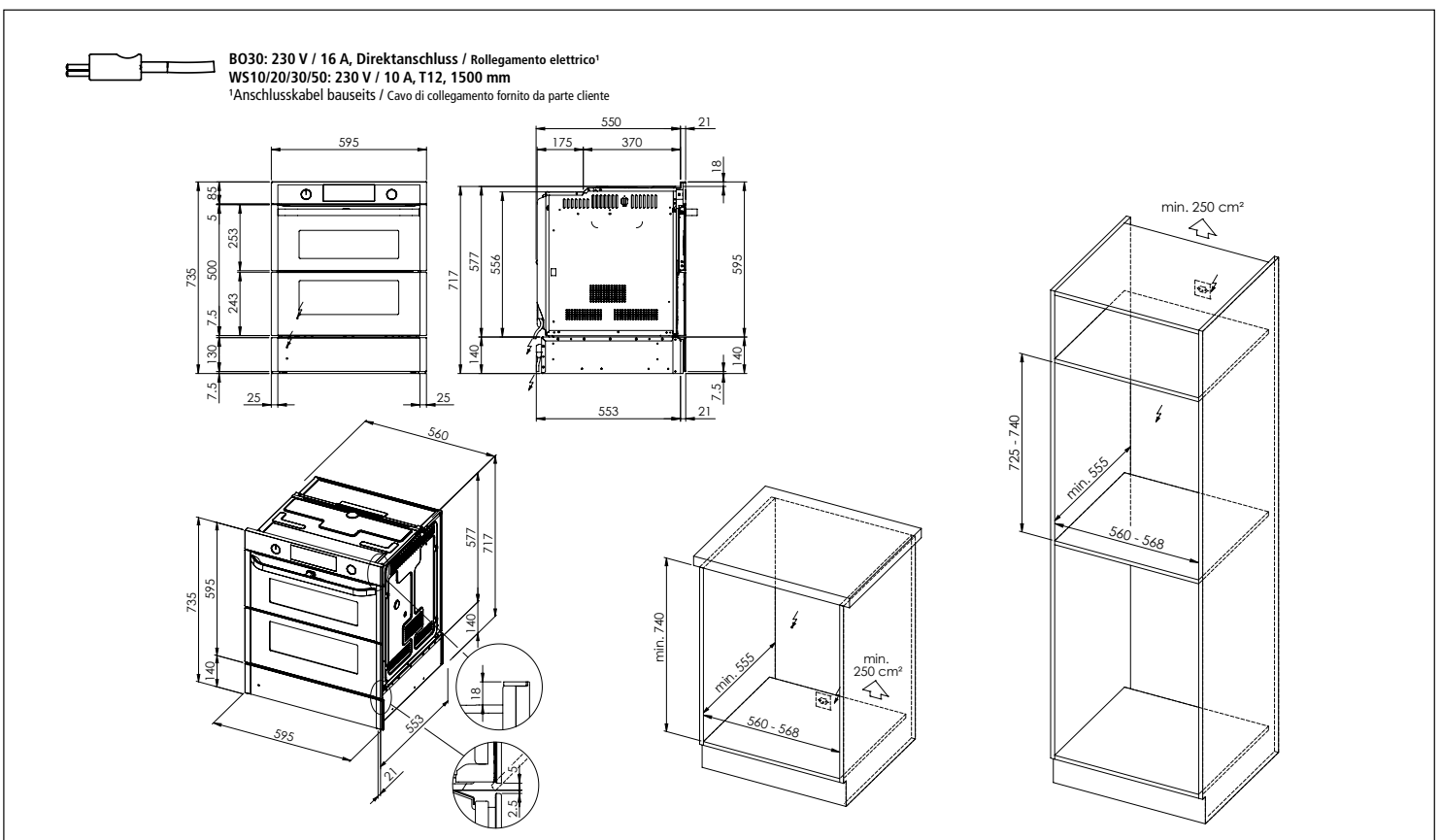

# Samsung Backöfen und Kompaktgeräte: Masszeichnungen Forni e apparecchi compatti Samsung: disegni quotati

## Samsung Backofen BO50 Dual Cook Forno Samsung BO50 Dual Cook

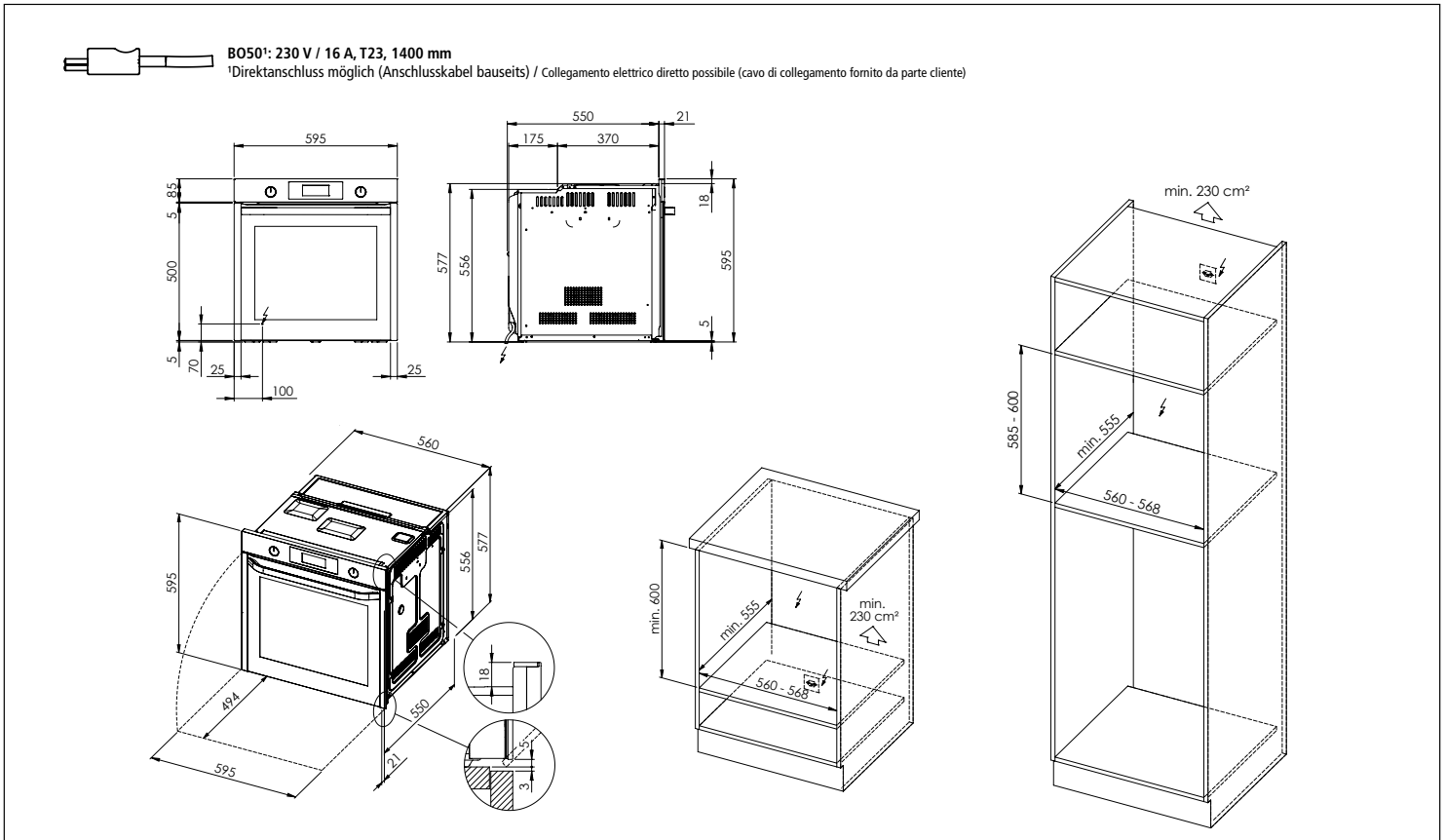

## Samsung Backofen BO50 Dual Cook mit Wärmeschublade WS10/20/30/50 Forno Samsung BO50 Dual Cook con cassetto scaldavivande WS10/20/30/50

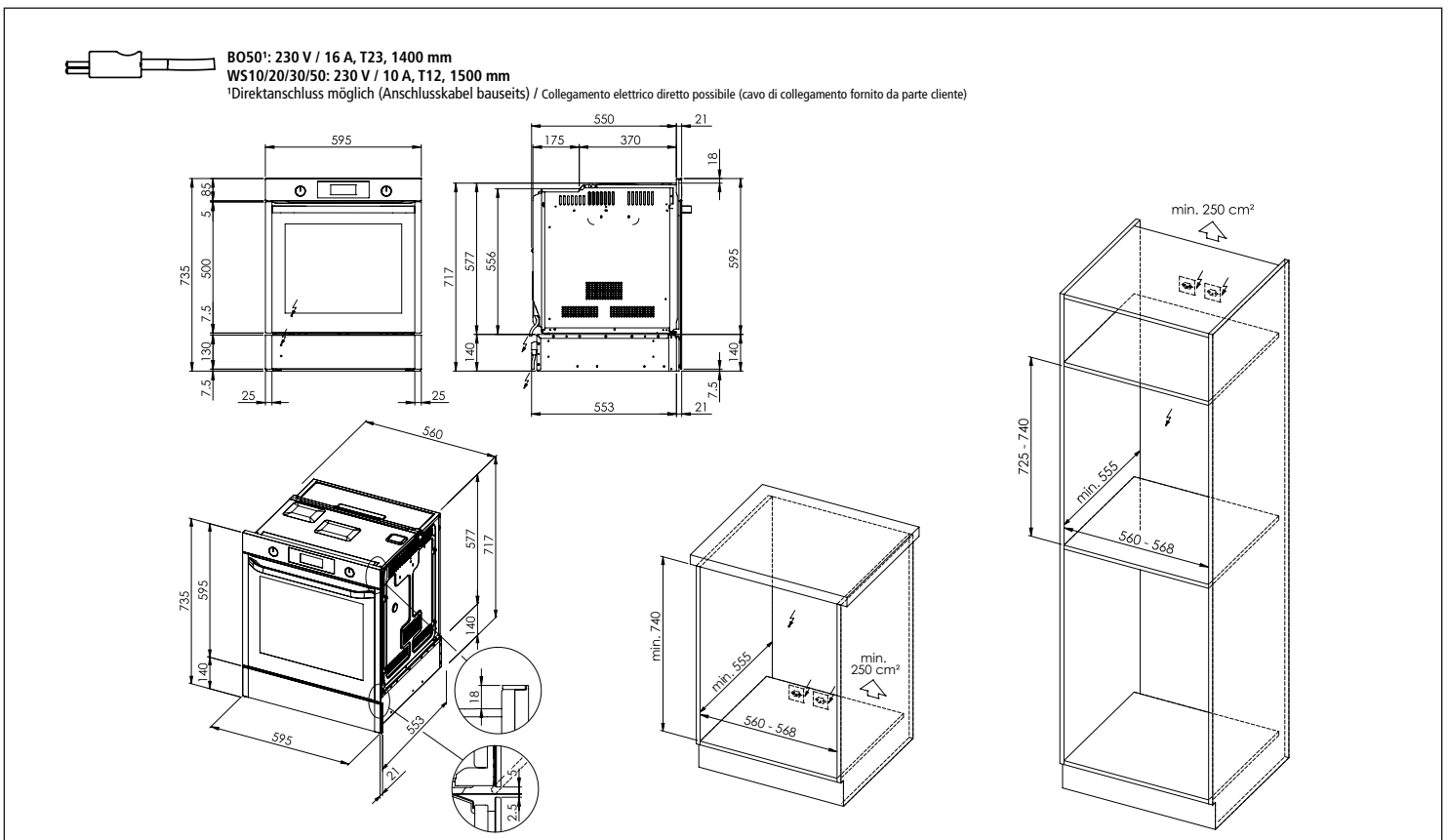

# Samsung Backöfen und Kompaktgeräte: Masszeichnungen

## Forni e apparecchi compatti Samsung: disegni quotati

### Samsung Backofen BO60 Dual Fan

#### Forno Samsung BO60 Dual Fan

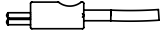

BO60<sup>1</sup>: 230 V / 16 A, T23, 1400 mm

<sup>1</sup>Direktanschluss möglich (Anschlusskabel bauseits) / Collegamento elettrico diretto possibile (cavo di collegamento fornito da parte cliente)

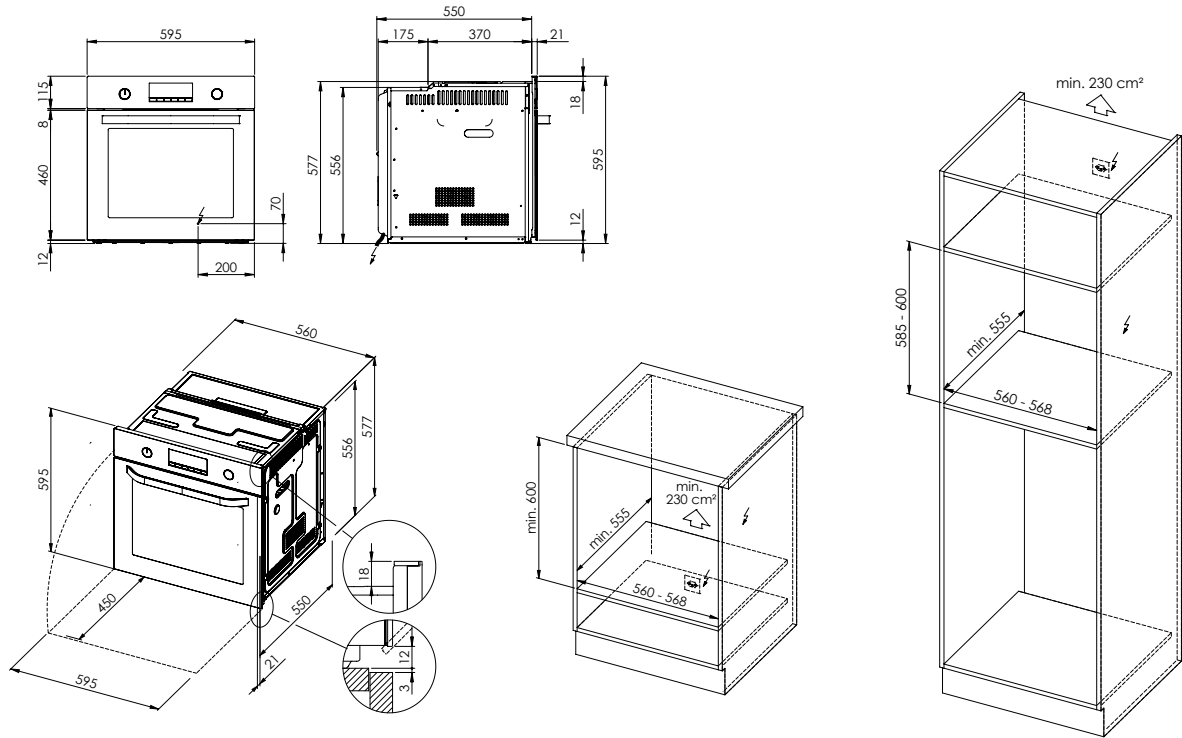

### Samsung Backofen BO70 Dual Fan

#### Forno Samsung BO70 Dual Fan

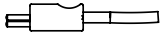

BO70<sup>1</sup>: 230 V / 16 A, T23, 1400 mm

<sup>1</sup>Direktanschluss möglich (Anschlusskabel bauseits) / Collegamento elettrico diretto possibile (cavo di collegamento fornito da parte cliente)

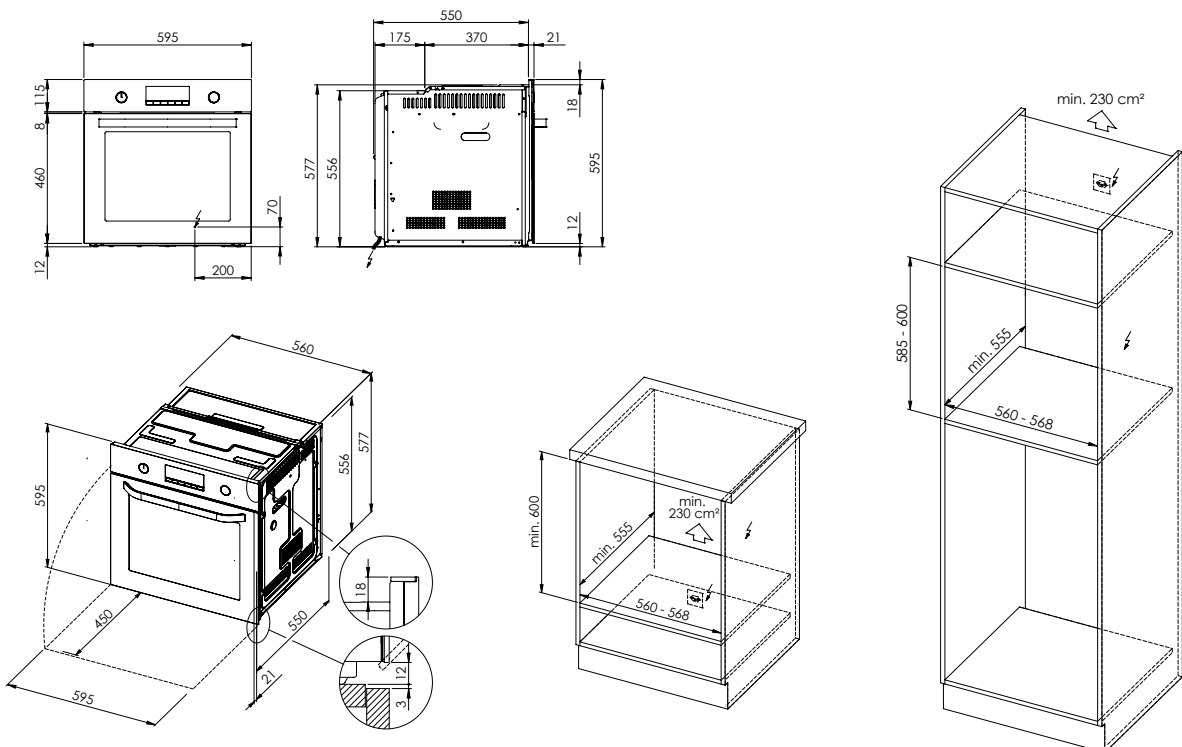

# Samsung Backöfen und Kompaktgeräte: Masszeichnungen Forni e apparecchi compatti Samsung: disegni quotati

## Samsung Combi-Steamer CS40 Kompaktgerät Apparecchio compatto: Combi Steamer Samsung CS40

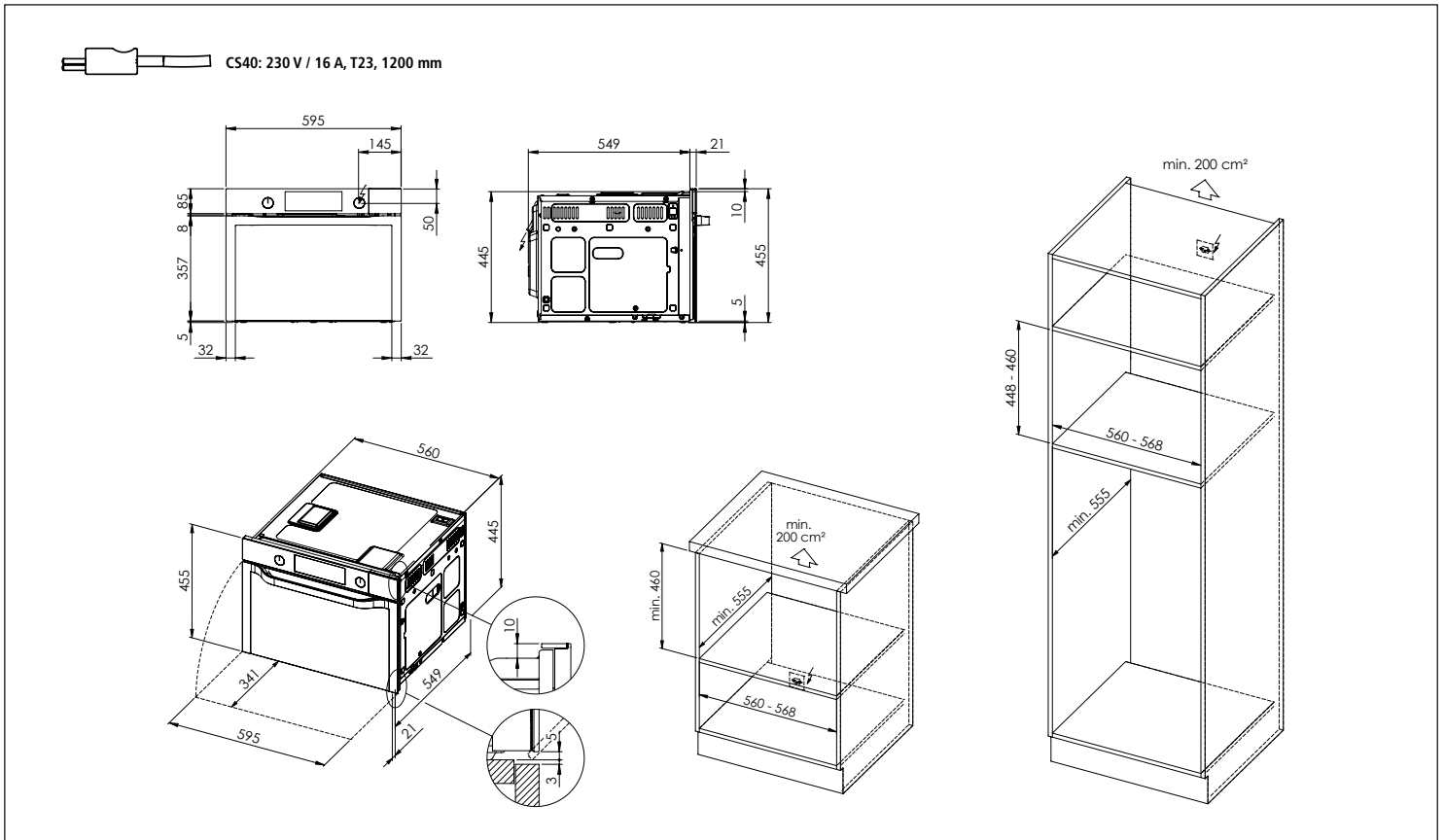

## Samsung Combi-Steamer CS40 Kompaktgerät mit Wärmeschublade WS40 Apparecchio compatto: Combi Steamer Samsung CS40 + cassetto scaldavivande WS40

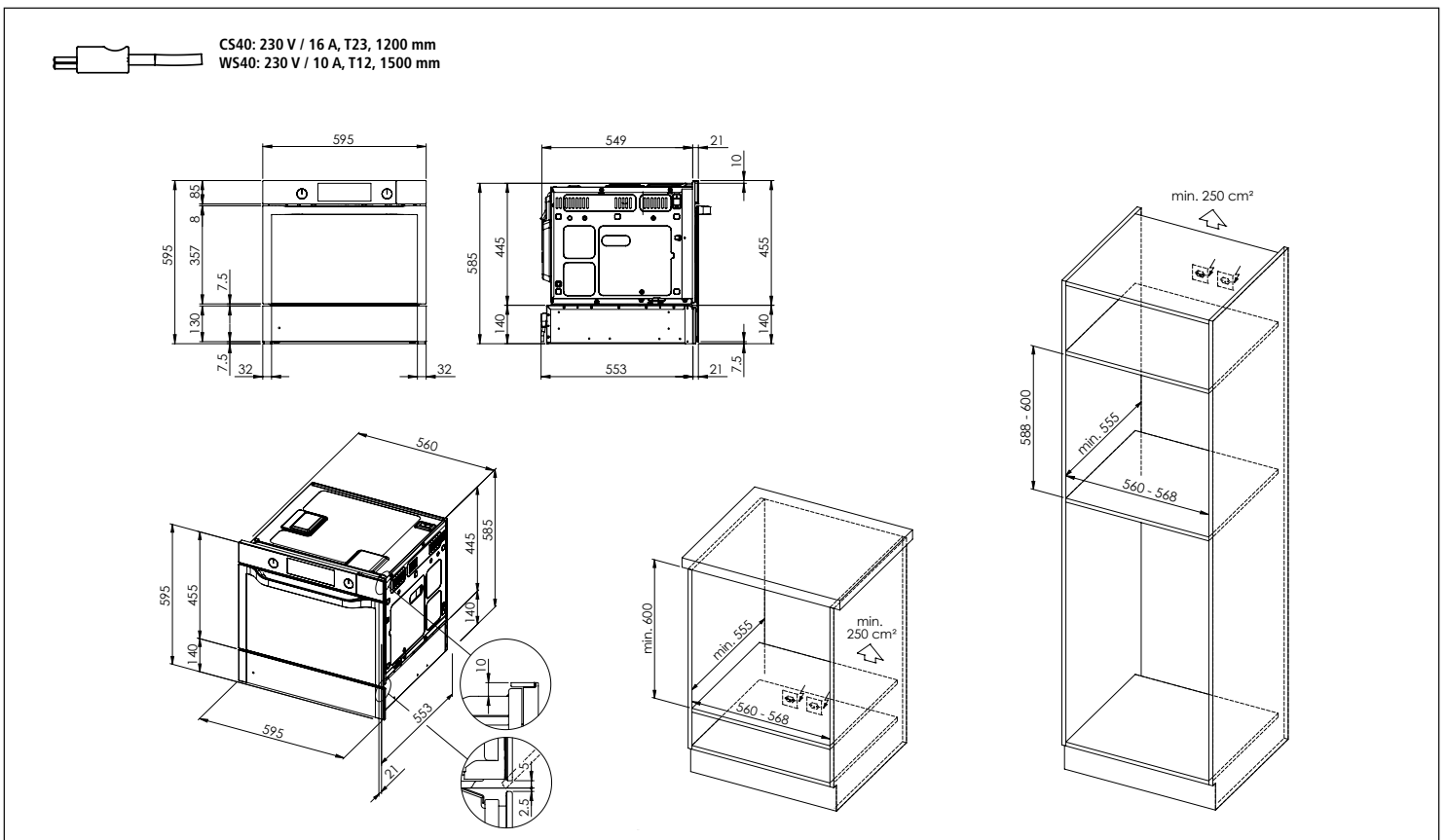

# Samsung Backöfen und Kompaktgeräte: Masszeichnungen Forni e apparecchi compatti Samsung: disegni quotati

Set Angebot «Combi-Steamer 2 x CS40»  
Offerta di set «Combi Steamer 2 x CS40»

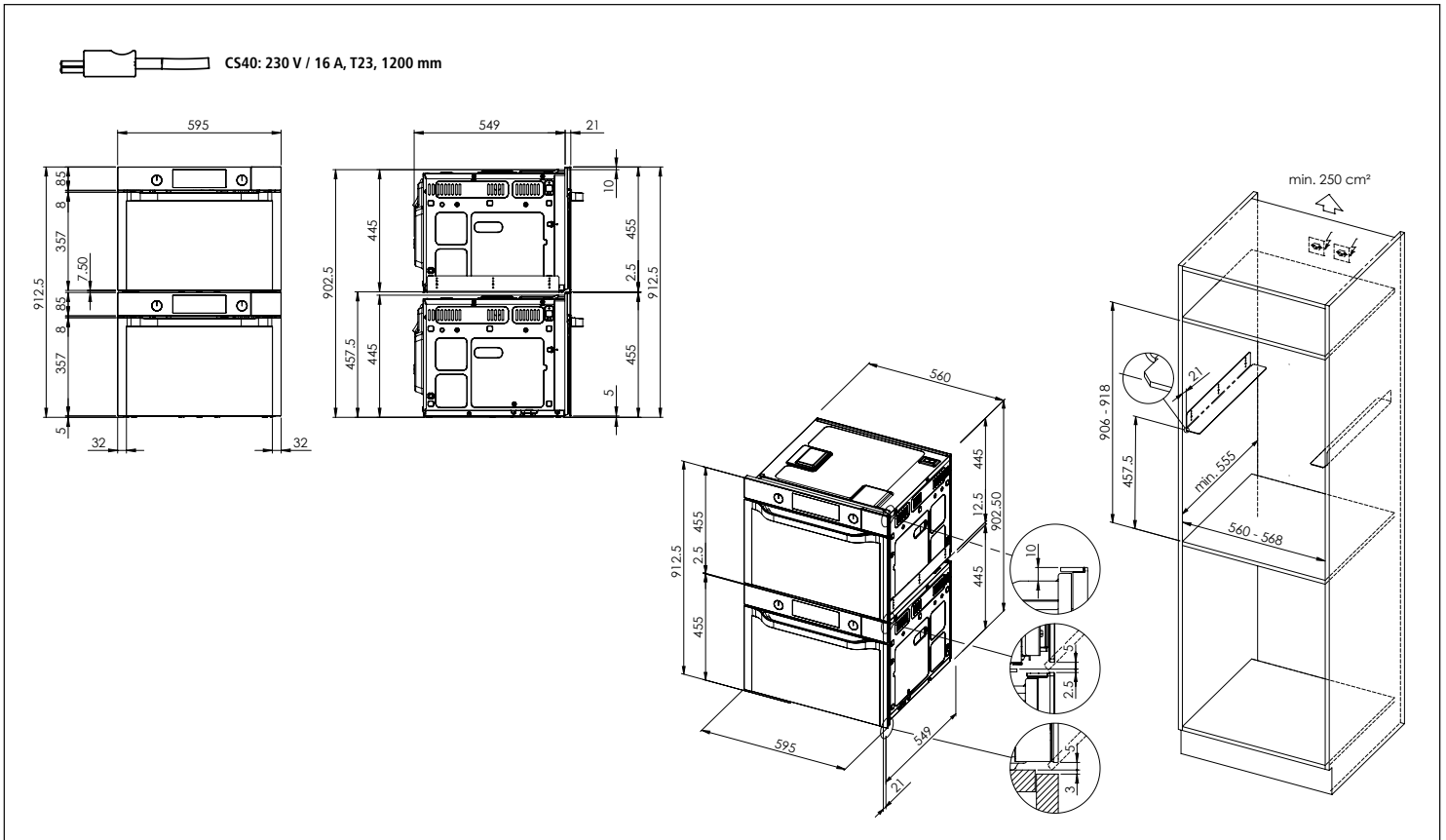

Set Angebot «Combi-Steamer 2 x CS40 + Wärmeschublade WS40»  
Offerta di set «Combi Steamer 2 x CS40 + cassetto scaldavivande WS40»

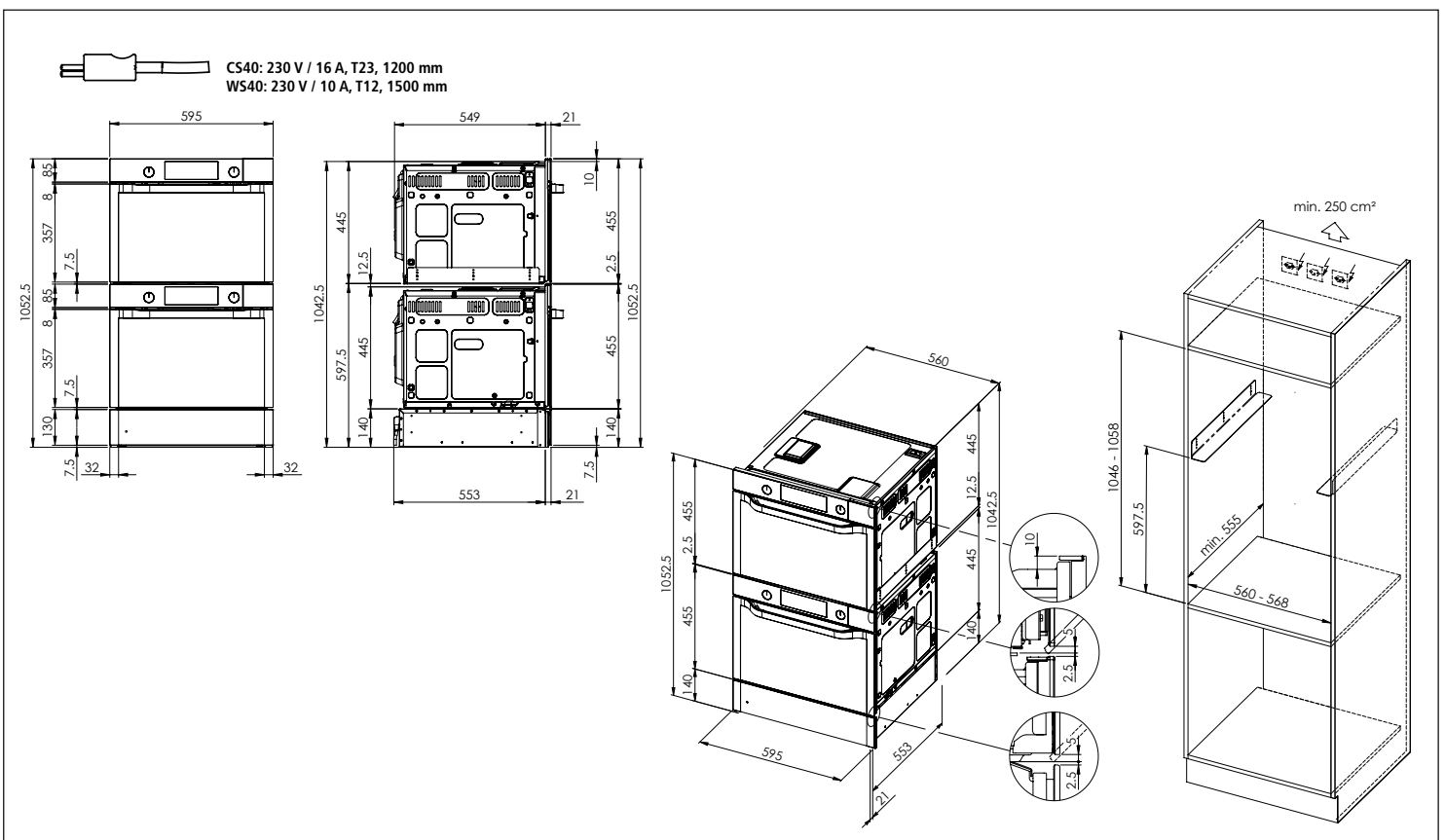

# Samsung Backöfen und Kompaktgeräte: Masszeichnungen

## Forni e apparecchi compatti Samsung: disegni quotati

**Samsung Backofen mit Mikrowelle BM30/50 Kompaktgerät**  
**Apparecchio compatto: forno con microonde Samsung BM30/50**

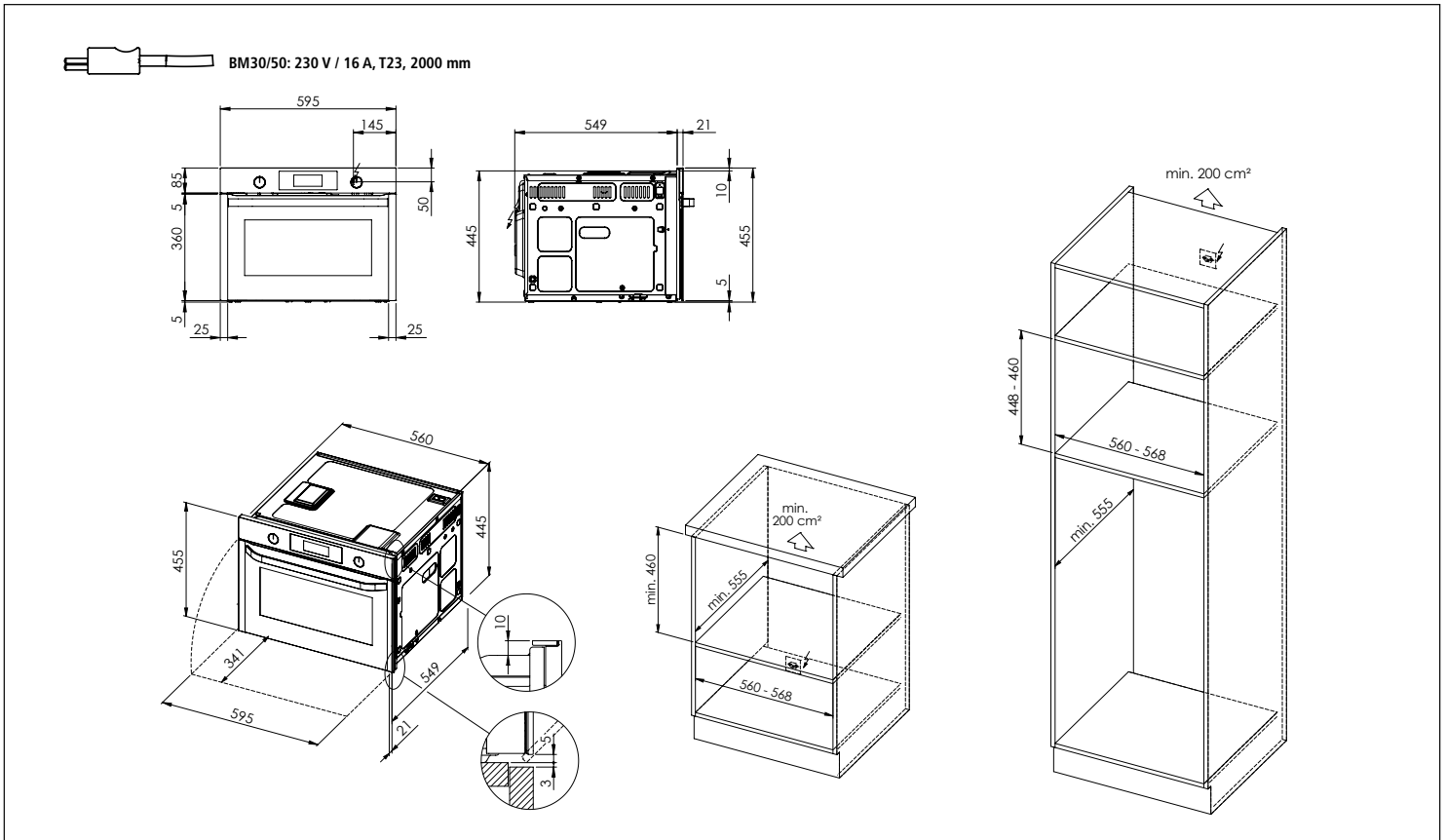

**Samsung Backofen mit Mikrowelle BM30/50 Kompaktgerät mit Wärmeschublade WS10/20/30/50**  
**Apparecchio compatto: forno con microonde Samsung BM30/50 con cassetto scaldavivande WS10/20/30/50**

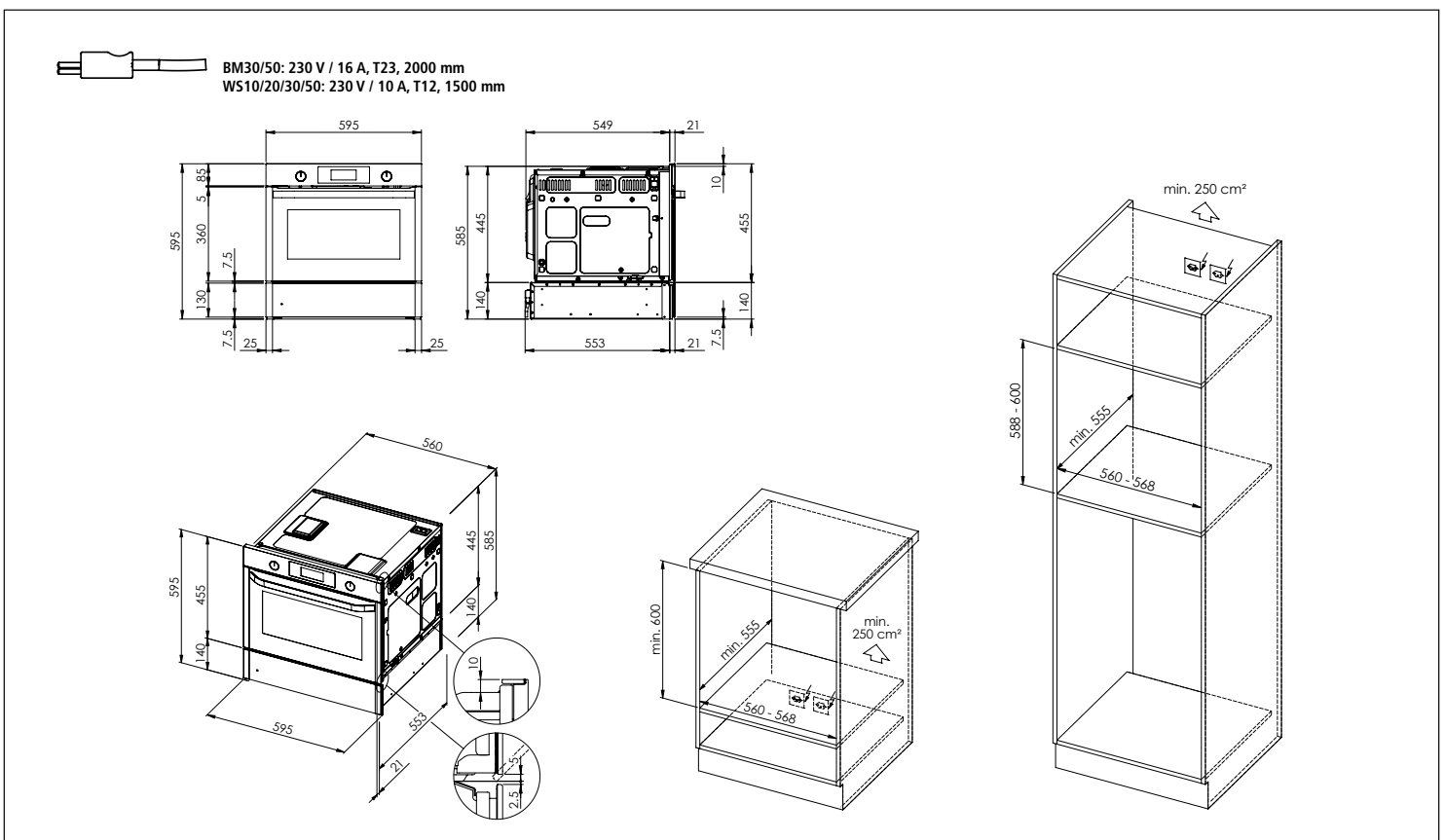

## Samsung Backöfen und Kompaktgeräte: Masszeichnungen Forni e apparecchi compatti Samsung: disegni quotati

Samsung Wärmeschublade WS10/20/30/50  
Cassetto scaldavivande Samsung WS10/20/30/50

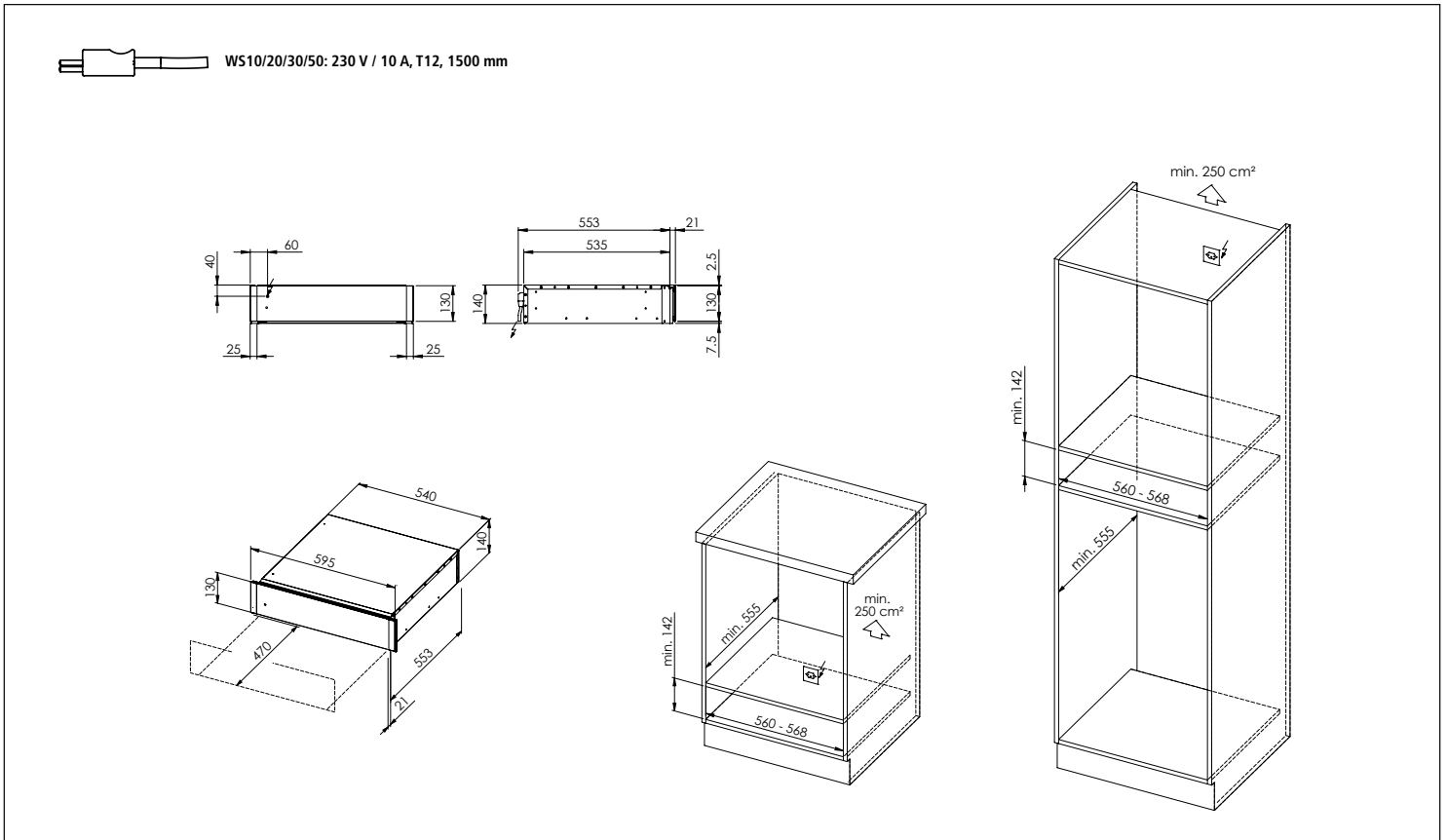

Samsung Wärmeschublade WS40  
Cassetto scaldavivande Samsung WS40

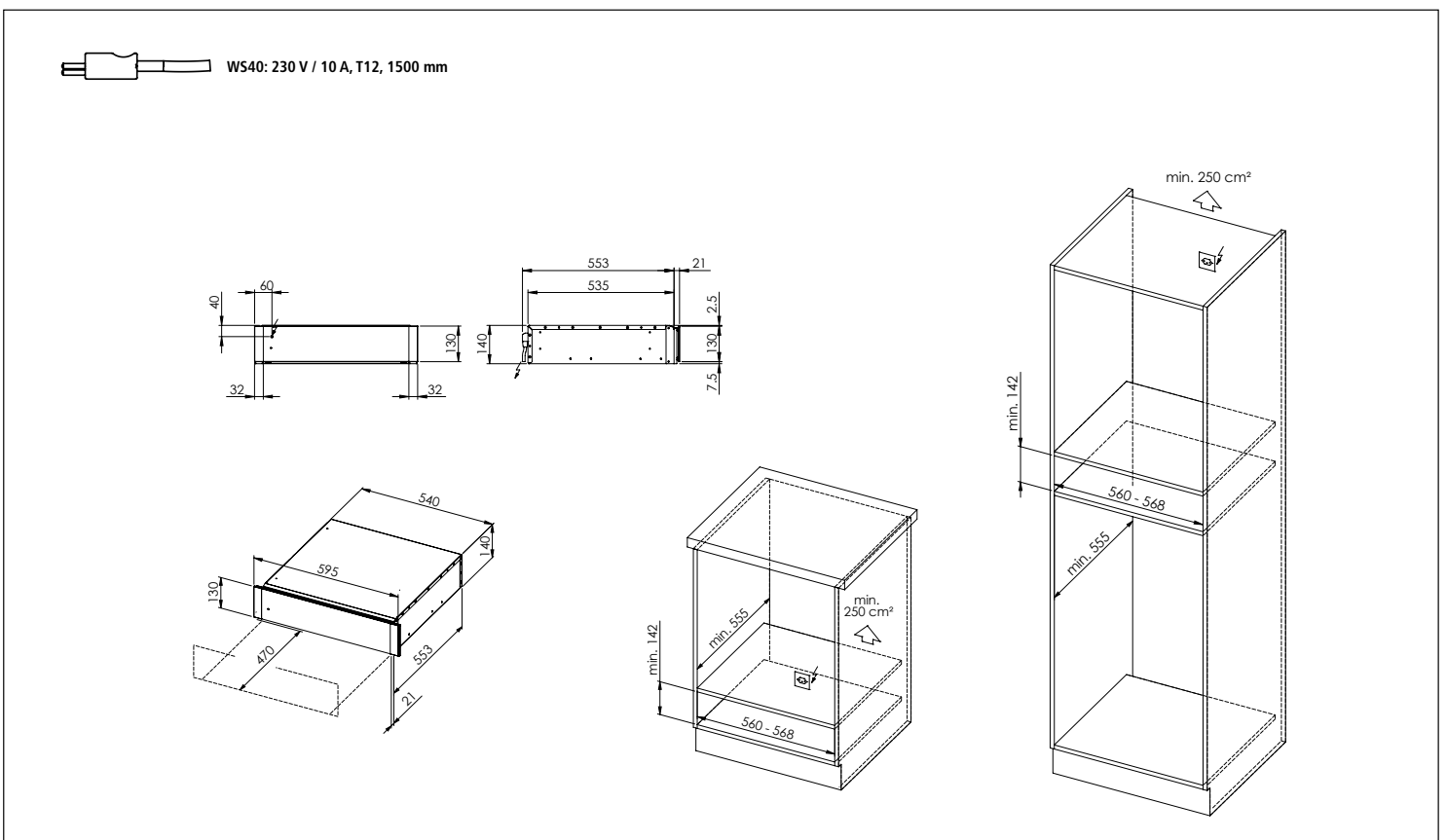

# Samsung Backöfen und Kompaktgeräte: Masszeichnungen

## Forni e apparecchi compatti Samsung: disegni quotati

Samsung BO und BO  
 Samsung BO e BO

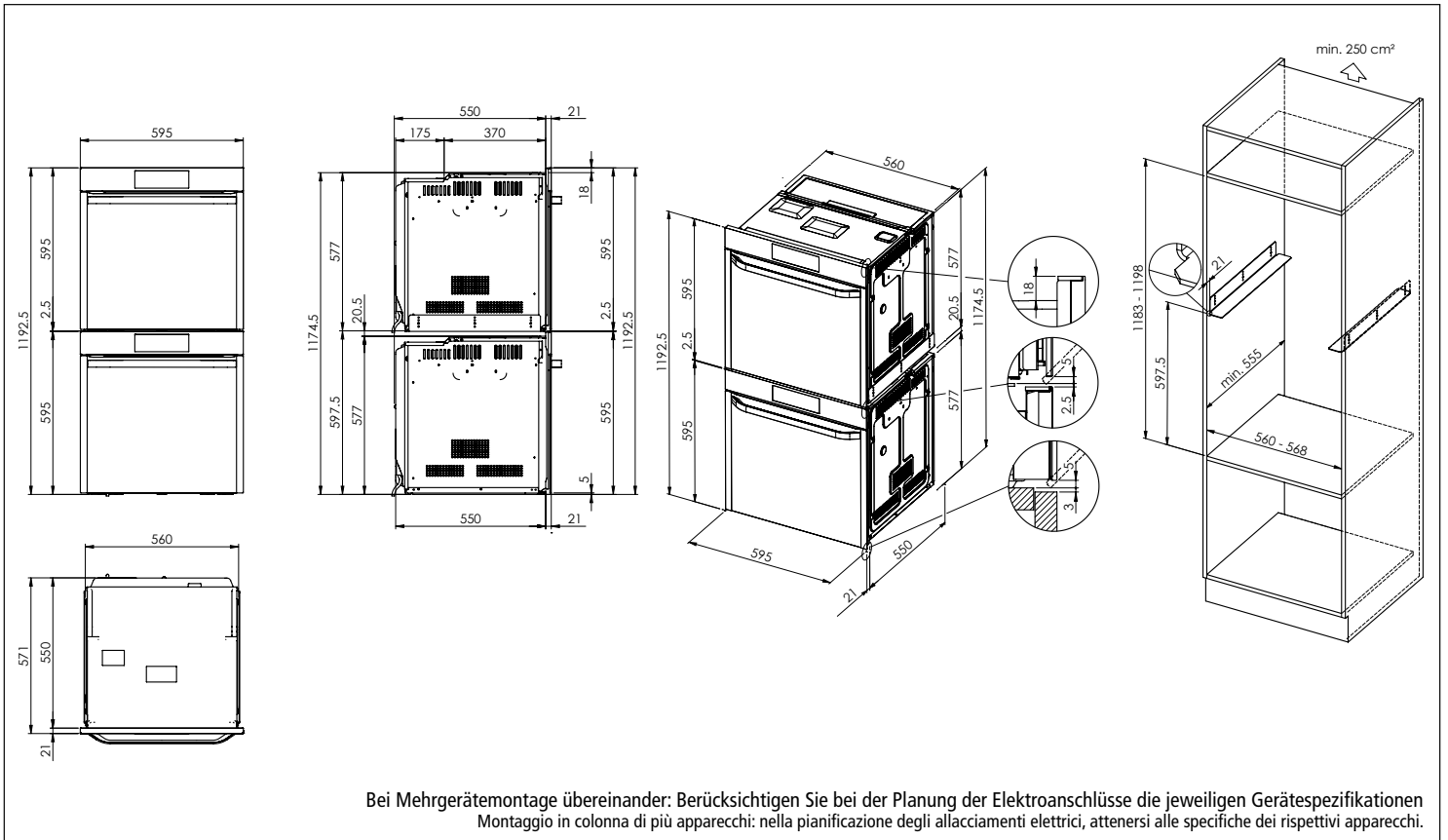

Samsung WS und BO und BO  
 Samsung WS e BO e BO

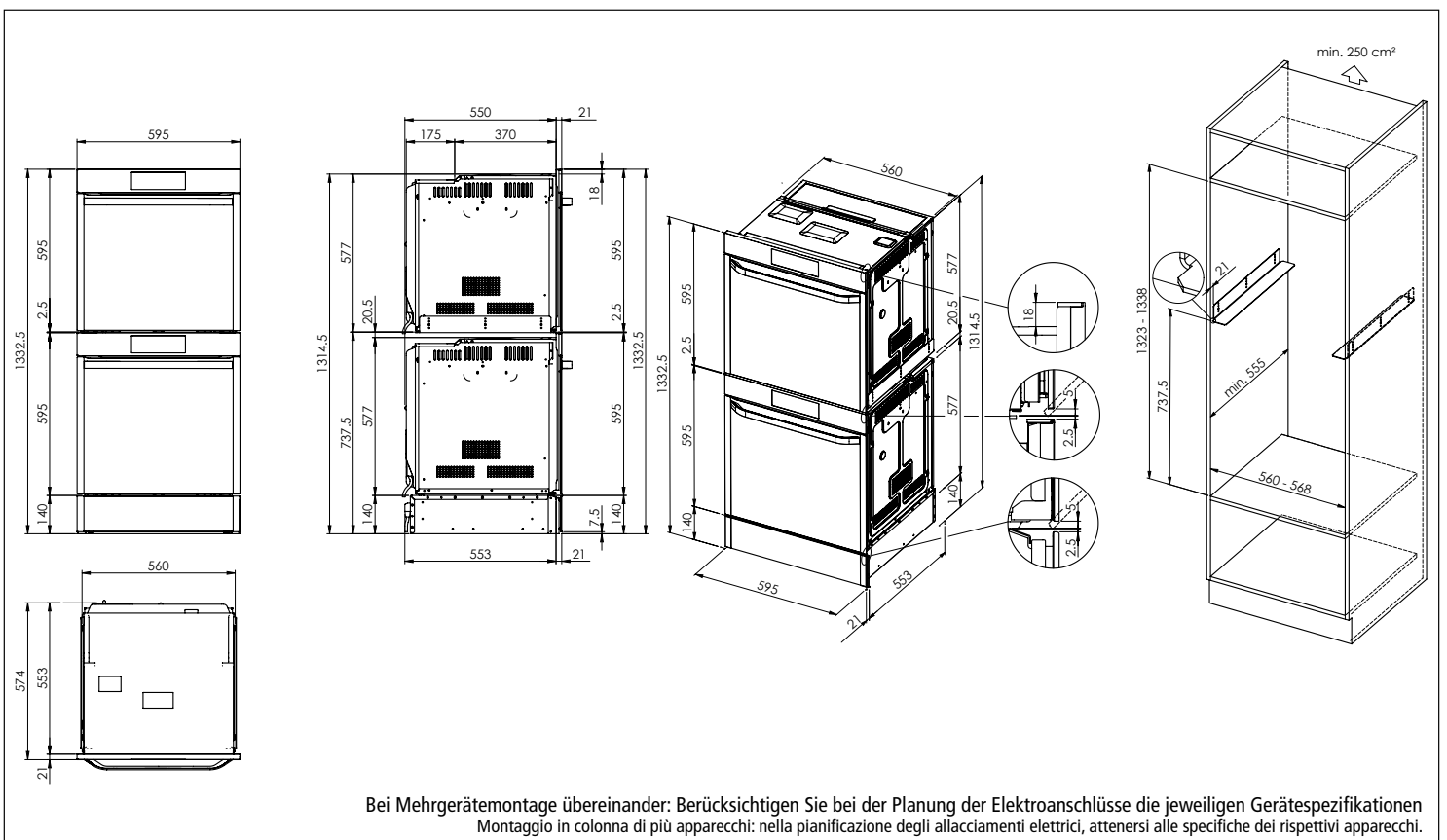

## Samsung Backöfen und Kompaktgeräte: Masszeichnungen Forni e apparecchi compatti Samsung: disegni quotati

Samsung BO und BM oder CS  
Samsung BO e BM o CS

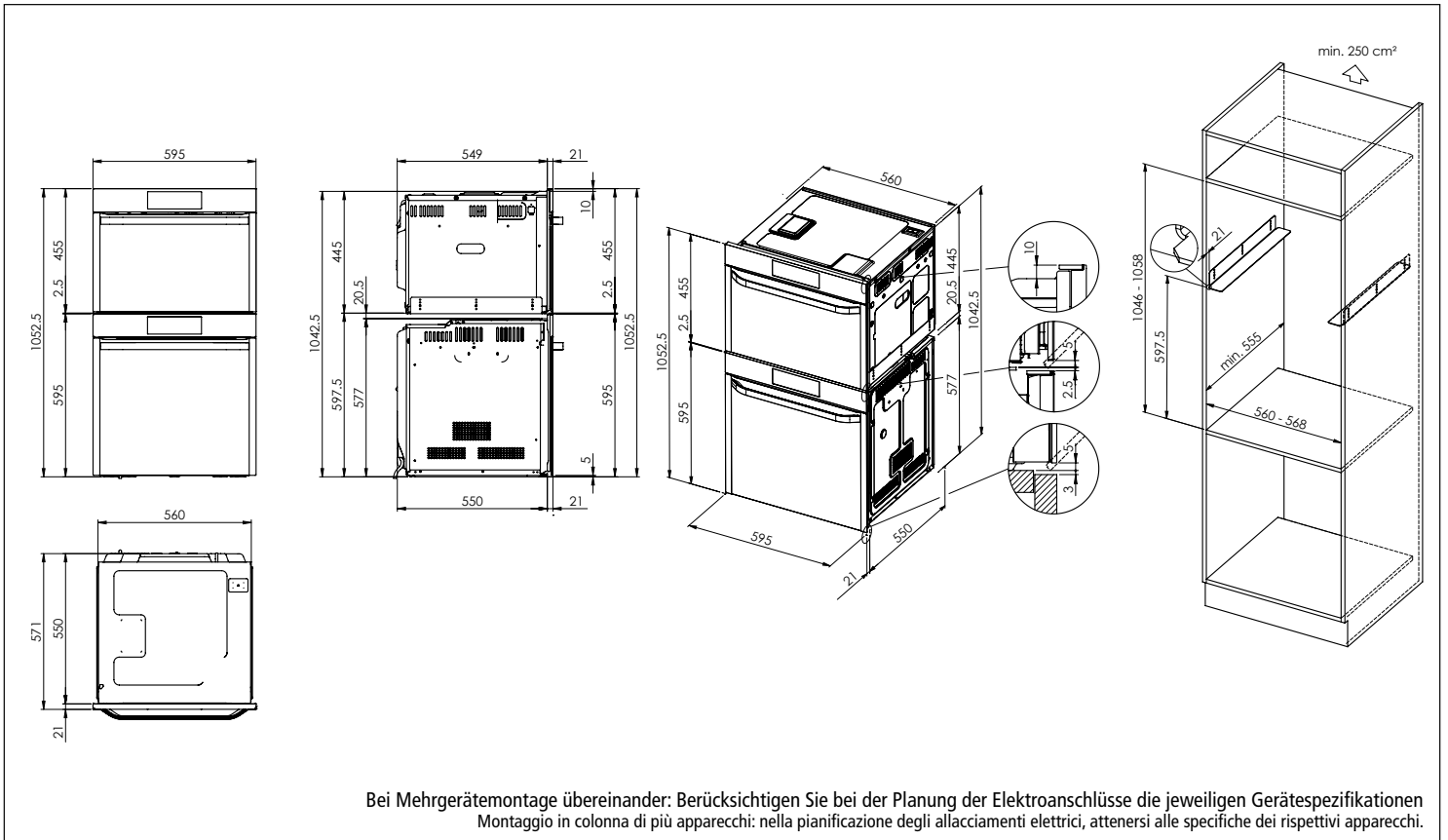

Samsung WS und BO und BM oder CS  
Samsung WS e BO e BM o CS

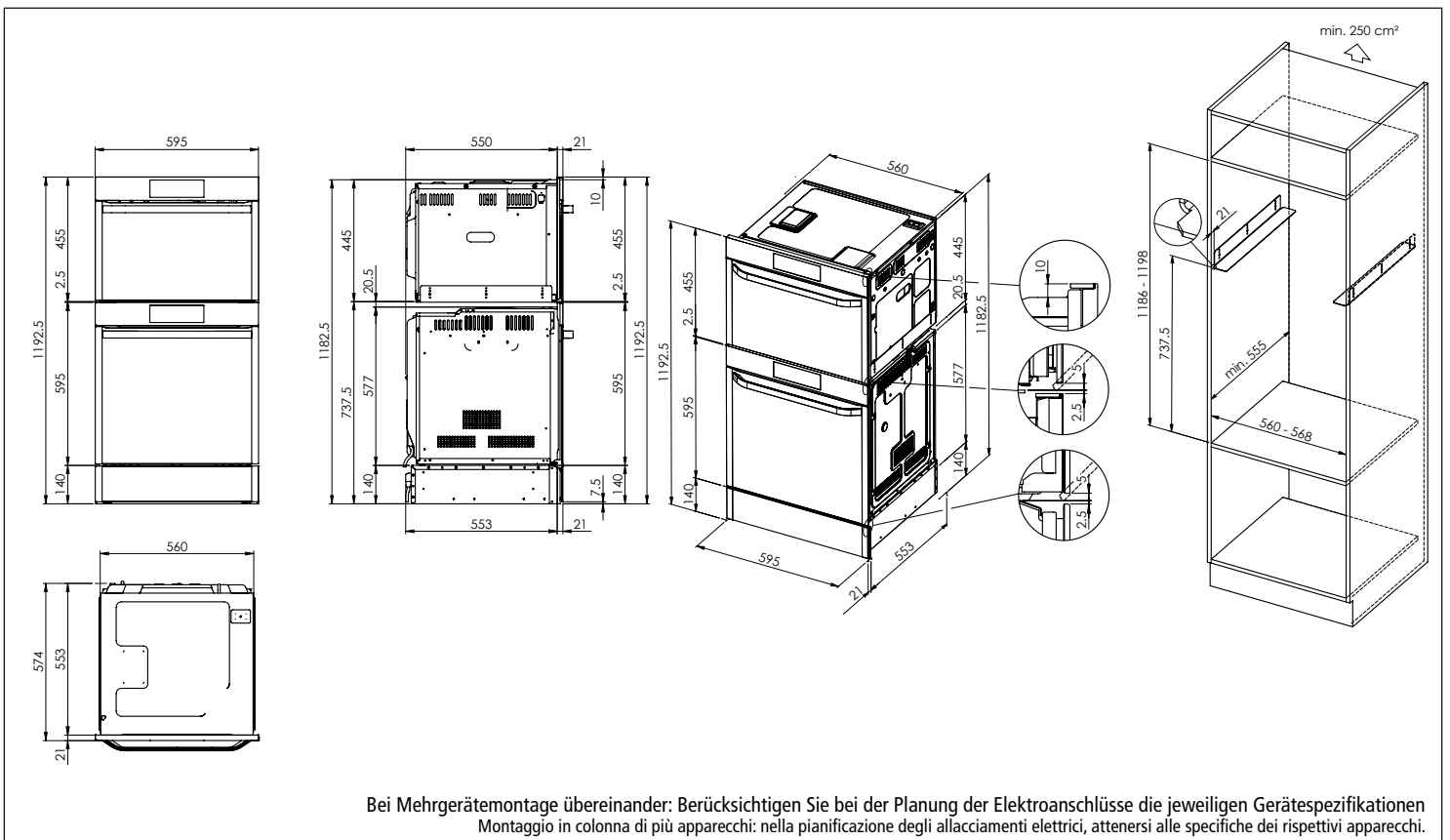

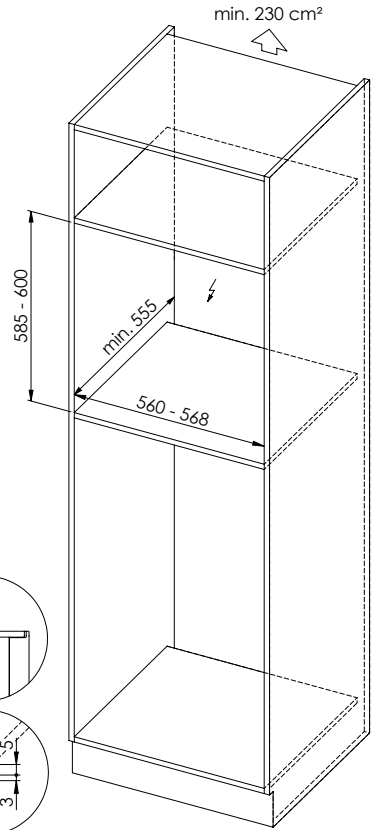
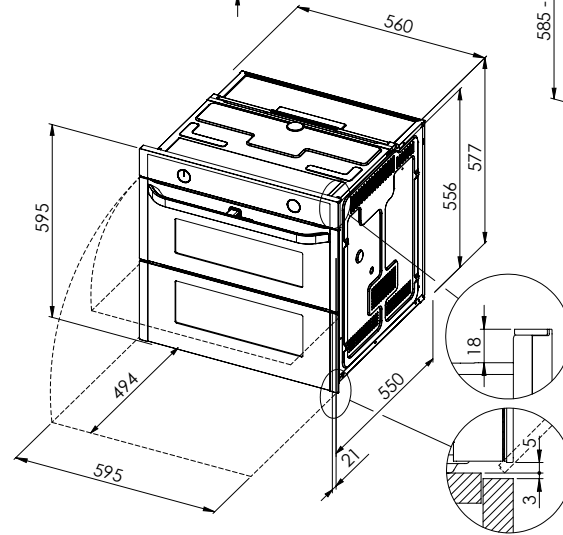
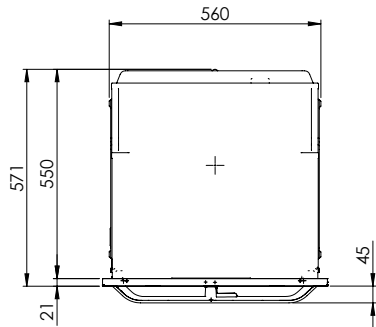
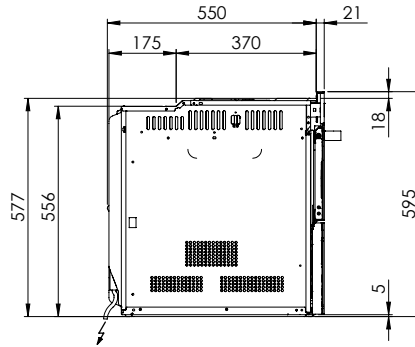
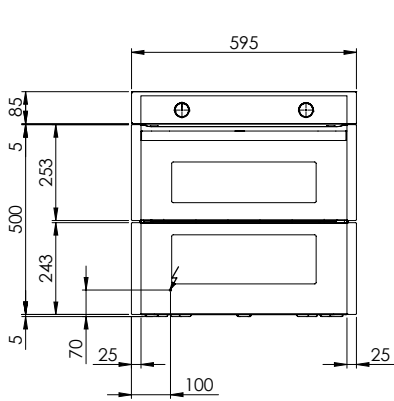

 BO20: 230 V / 16 A, Direktanschluss, Raccordement électrique, Collegamento elettrico<sup>1</sup>

<sup>1</sup>Anschlusskabel bauseits

Câble de raccordement fourni par le client

Cavo di collegamento fornito da parte cliente

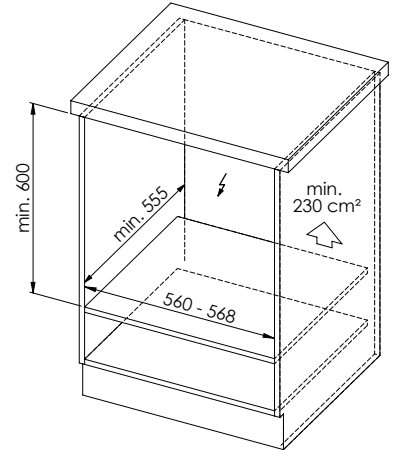
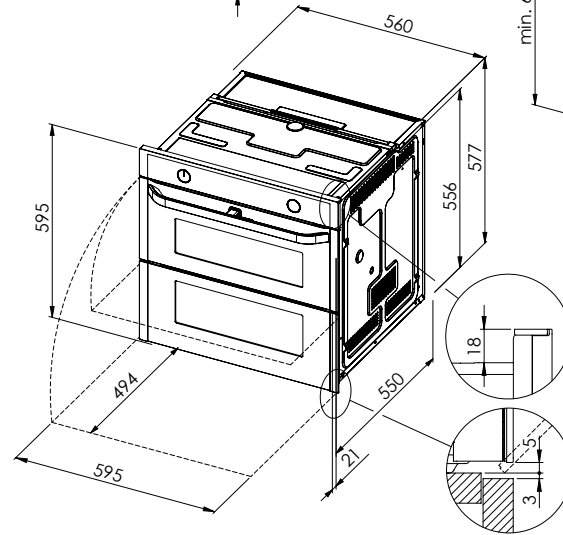
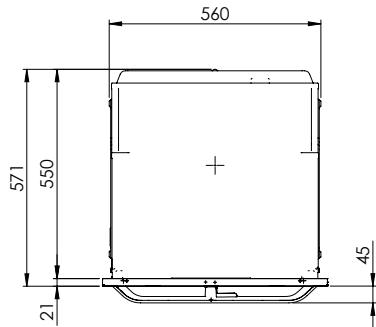
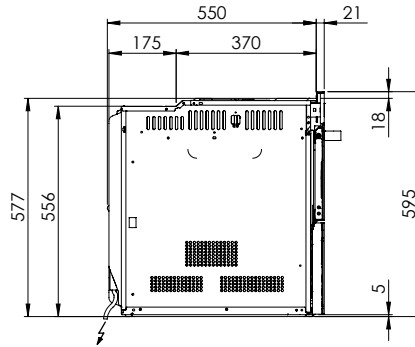
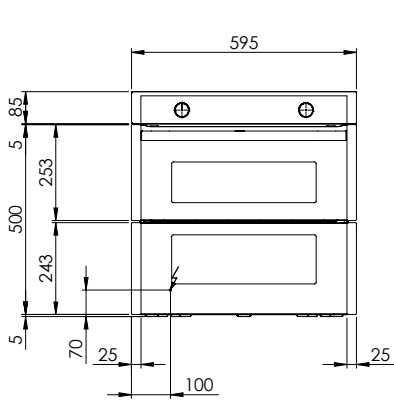

 BO20: 230 V / 16 A, Direktanschluss, Raccordement électrique, Collegamento elettrico<sup>1</sup>

<sup>1</sup>Anschlusskabel bauseits

Câble de raccordement fourni par le client

Cavo di collegamento fornito da parte cliente

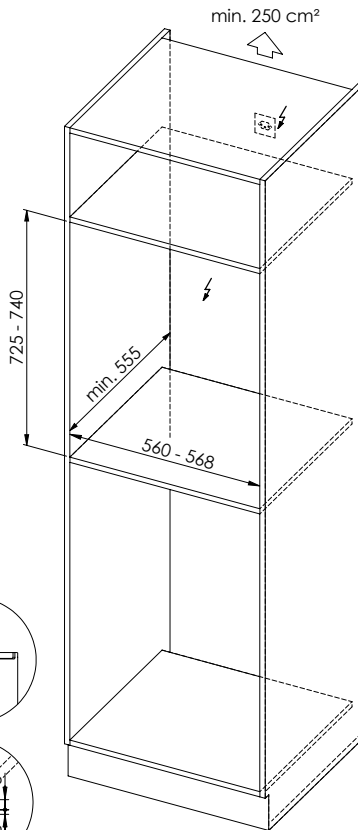
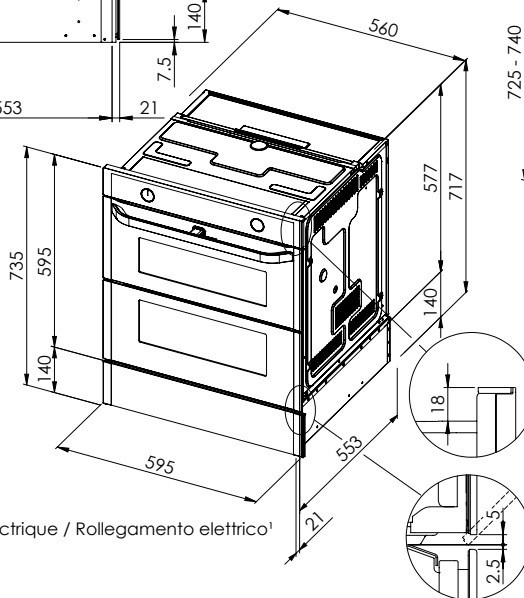
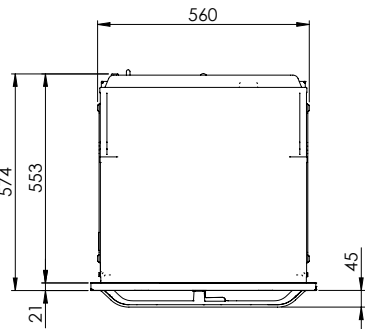
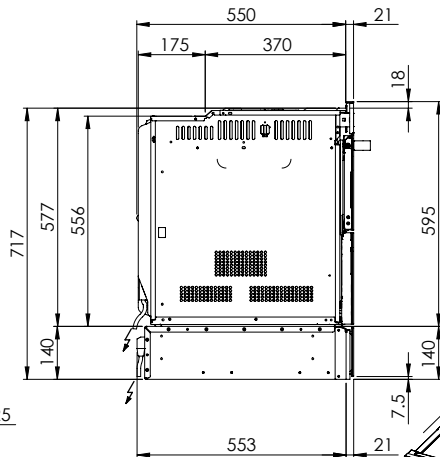
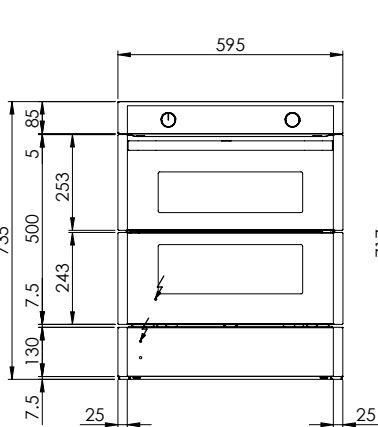

BO20: 230 V / 16 A, Direktanschluss / Raccordement électrique / Rollegamento elettrico  
 WS10/20/30/50: 230 V / 10 A, T12, 1500 mm

\*Anschlusskabel bauseits  
 Câble de raccordement fourni par le client  
 Cavo di collegamento fornito da parte cliente

# Samsung BO20 & WS10/20/30/50

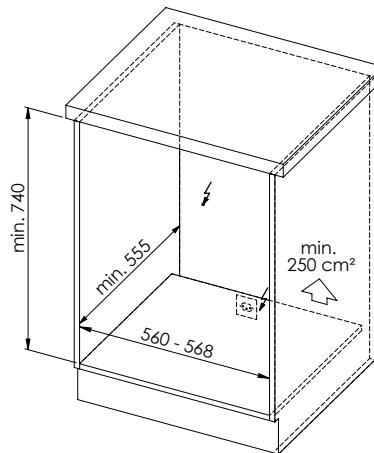
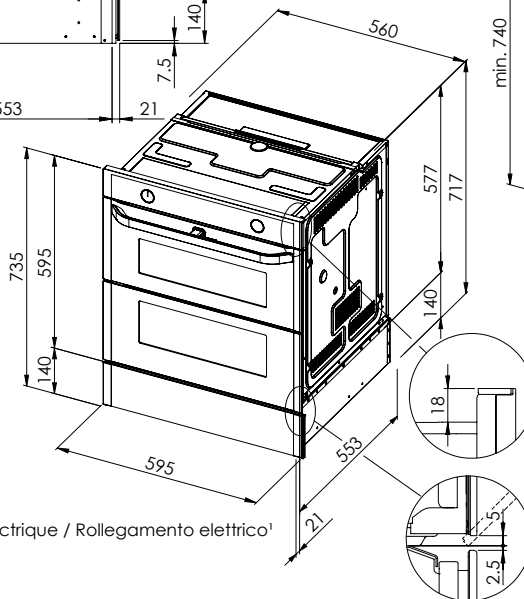
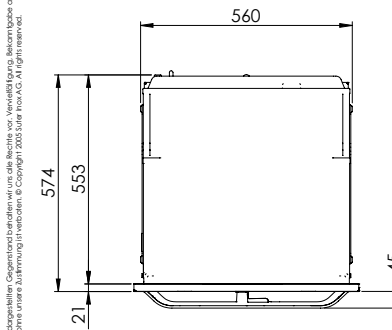
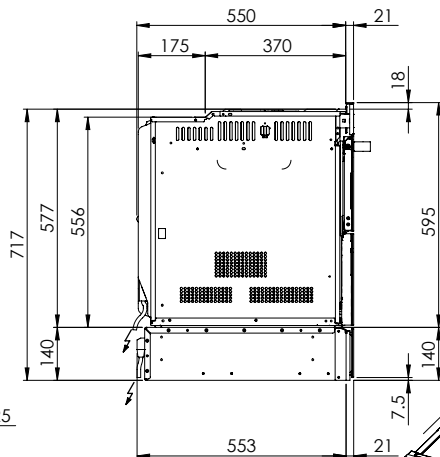
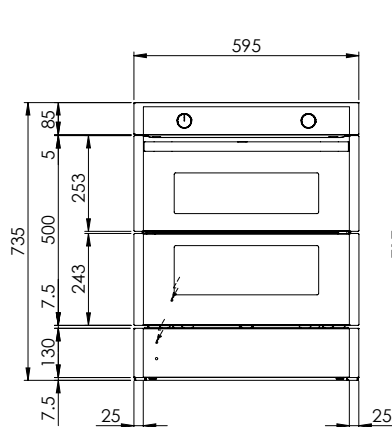

BO20: 230 V / 16 A, Direktanschluss / Raccordement électrique / Rollegamento elettrico'  
 WS10/20/30/50: 230 V / 10 A, T12, 1500 mm

'Anschlusskabel bauseits  
 Câble de raccordement fourni par le client  
 Cavo di collegamento fornito da parte cliente

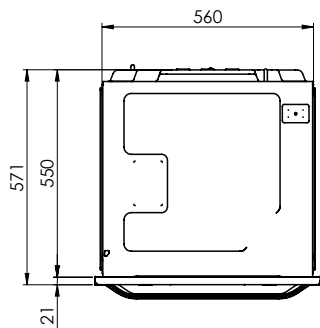
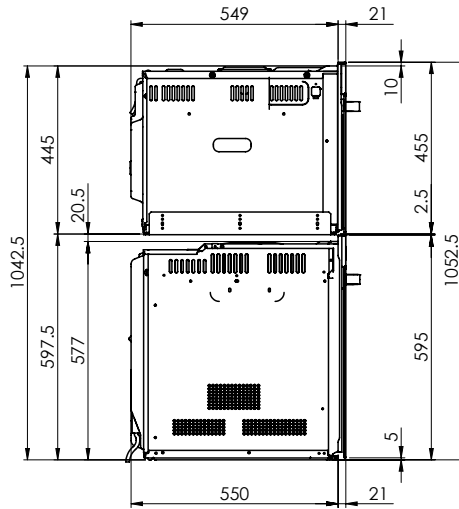
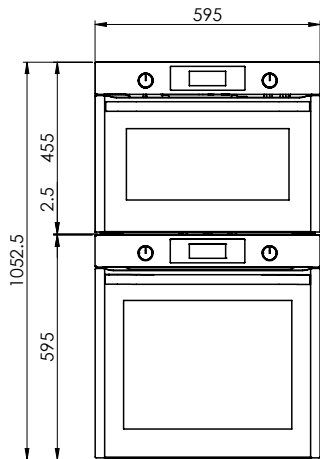

Bei Mehrgerätemontage übereinander: Berücksichtigen Sie bei der Planung der Elektroanschlüsse die jeweiligen Gerätespezifikationen.  
 Montage de plusieurs appareils l'un sur l'autre: veuillez tenir compte des spécifications de chaque appareil lors de la planification des raccordements électriques.  
 Montaggio in colonna di più apparecchi: nella pianificazione degli allacciamenti elettrici, attenersi alle specifiche dei rispettivi apparecchi.

Es ist das Nachwendrecht vorbehalten, dieses Diagramm, Gegenstandsbildungen, Zeichnungen, Verzeichnisse, Tabellen, Listen, Kataloge, Prospekte, Pläne oder andere Dokumente, die in diesem Dokument enthalten sind, ohne unsere Zustimmung in irgendeiner Form zu reproduzieren, zu kopieren, zu verbreiten oder für andere Zwecke zu verwenden. © Copyright 2003 Suter Inox AG. All rights reserved.



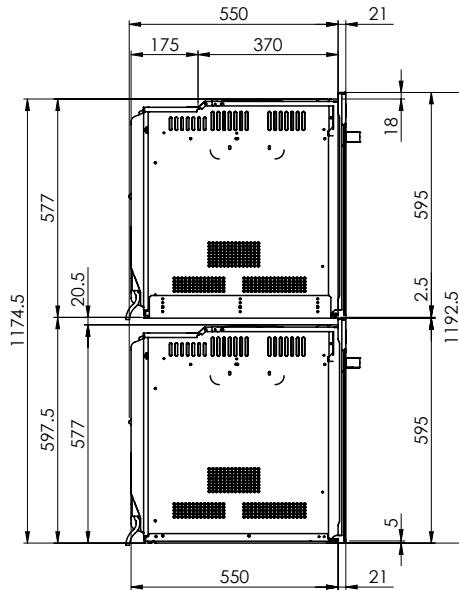
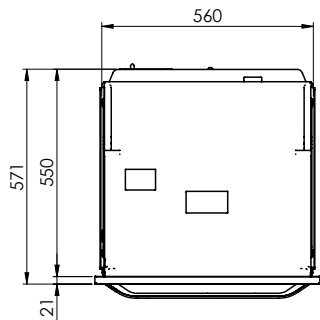
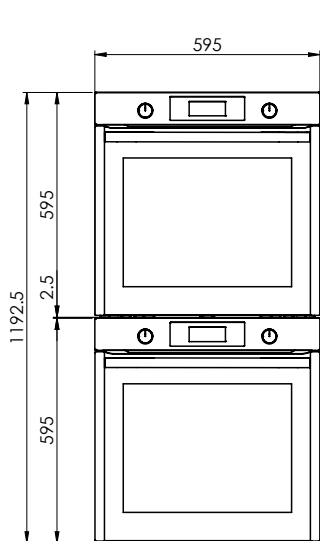

Bei Mehrgerätemontage übereinander: Berücksichtigen Sie bei der Planung der Elektroanschlüsse die jeweiligen Gerätespezifikationen.  
 Montage de plusieurs appareils l'un sur l'autre: veuillez tenir compte des spécifications de chaque appareil lors de la planification des raccordements électriques.  
 Montaggio in colonna di più apparecchi: nella pianificazione degli allacciamenti elettrici, attenersi alle specifiche dei rispettivi apparecchi.



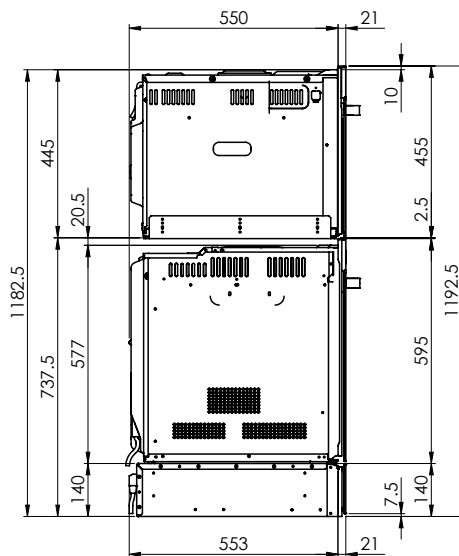
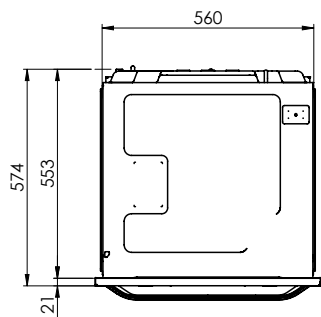
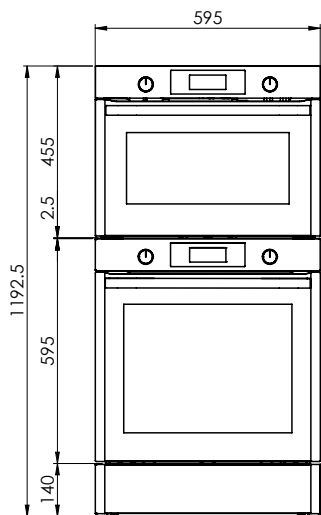

Bei Mehrgerätemontage übereinander: Berücksichtigen Sie bei der Planung der Elektroanschlüsse die jeweiligen Gerätespezifikationen.  
 Montage de plusieurs appareils l'un sur l'autre: veuillez tenir compte des spécifications de chaque appareil lors de la planification des raccordements électriques.  
 Montaggio in colonna di più apparecchi: nella pianificazione degli allacciamenti elettrici, attenersi alle specifiche dei rispettivi apparecchi.



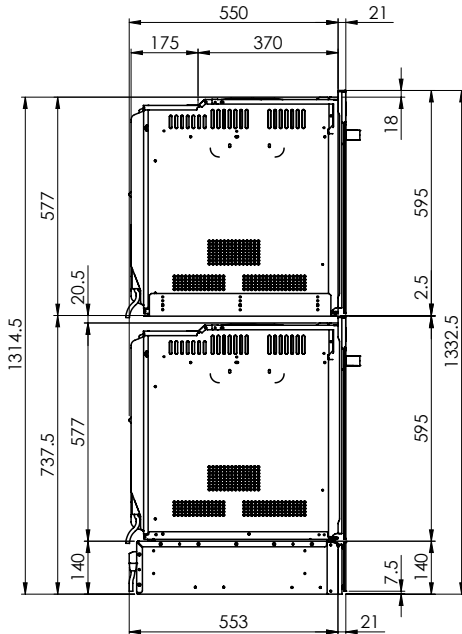
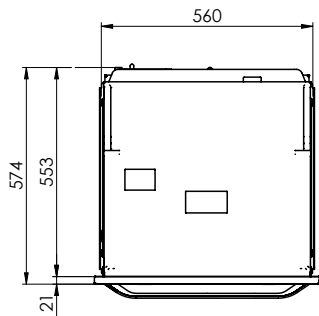
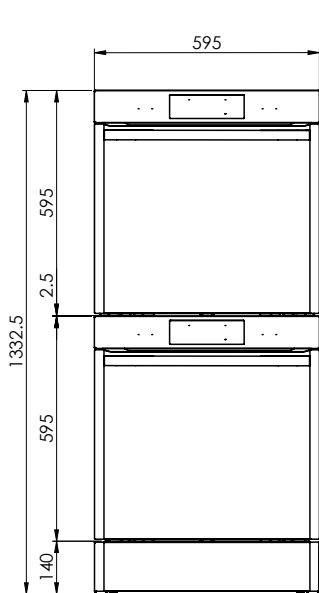

Bei Mehrgerätemontage übereinander: Berücksichtigen Sie bei der Planung der Elektroanschlüsse die jeweiligen Gerätespezifikationen.  
 Montage de plusieurs appareils l'un sur l'autre: veuillez tenir compte des spécifications de chaque appareil lors de la planification des raccordements électriques.  
 Montaggio in colonna di più apparecchi: nella pianificazione degli allacciamenti elettrici, attenersi alle specifiche dei rispettivi apparecchi.

