

## Linero LIO 50F/7

[> Weblink](#)

Dimensioni base 55 cm

**Montaggio**

Lavelli a filo top

**Modello**

LIO 50F/7

**Materiale**

Acciaio inox 18/10

**N. di articolo**

10.105.669.00

**Dimensioni base**

55 cm

**Piletta**

3½" Salvaspazio

**Finitura**

Opaco

**Prezzo in CHF**

1'493.- IVA esclusa

**Dimensioni lavello**

500x400x175mm

**Raggi d'angolo**

15 mm

**Tecnologia di scarico e troppopieno**

Griglietta - tipo M



Placchetta di troppopieno a ribalta

**Premontaggio della piletta**

Premontaggio della piletta in fabbrica

**Distributore - opzioni di montaggio**

Posizione a scelta

**Tecnologia di scarico e troppopieno****Pomolo inclusi**

Advant

**Prezzi (aggiornati al 06.05.26 / IVA esclusa)**

Modello	Materiale	Piletta	N. di articolo	Prezzo in CHF	
Linero LIO 50F/7	Acciaio inox 18/10, Opaco	3½" Tipo	10.105.670.00	1'452.-	> Weblink
		3½" Salvaspazio	10.105.669.00	1'493.-	> Weblink
		3½" Salvaspazio	10.106.244.00	1'538.-	> Weblink
		3½" TouchFlow	10.105.668.00	1'691.-	> Weblink

**Ricambi**Qui trovate tutti gli accessori compatibili > [Weblink](#)



Für 12mm Arbeitsplatte.  
 Pour plan de travail de 12mm.  
 Per piano di lavoro da 12mm.

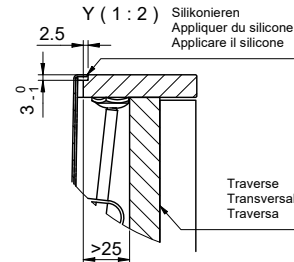
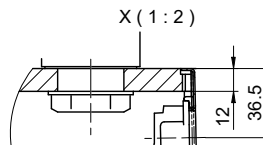

Für 13 - 30mm Arbeitsplatte.  
 Pour plan de travail de 13 - 30mm.  
 Per piano di lavoro da 13 - 30mm.

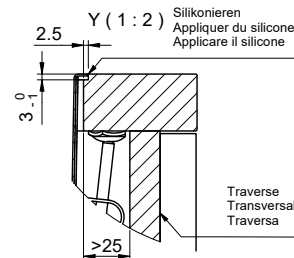
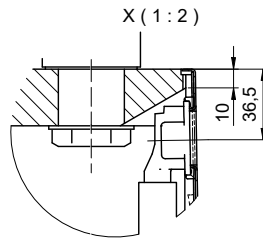

Für 13 - 50mm Arbeitsplatte.  
 Pour plan de travail de 13 - 50mm.  
 Per piano di lavoro da 13 - 50mm.

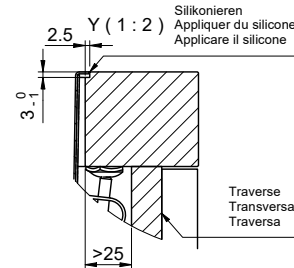
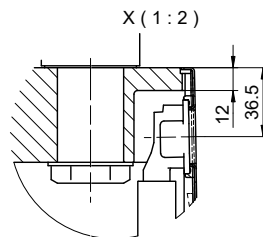

Bei der Planung die Traverse im Möbel beachten!

Faites attention à la barre transversale dans les meubles lors de la planification!

Presta attenzione alla traversa nei mobili durante la pianificazione!

Vom flächenbündigen Einbau in beschichtete Spanplatten raten wir ab.

Nous vous déconseillons le montage à fleur sur des panneaux de particules enduits.

Sconsigliamo il montaggio a filo top in pannelli di truciolato laminato.

# Linero LIO 50F/7 Desino

**Ausschnitt für flächenbündigen Einbau - Randbreite 7mm:**  
**Mesure de coupure pour montage à fleur - Bord de 7mm de largeur:**  
**Intaglio per montaggio a filo top - Larghezza bordo 7mm:**

Bohrung für Zug- und Druckknöpfe Ø14  
 Bohrung für Drehknopf Ø25

Trou pour boutons et Poussoirs de commande Ø14  
 Trou pour bouton rotatif Ø25

Foro per Pomelli tiranti e Pomelli pulsanti Ø14  
 Foro per Pomolo girevoli Ø25

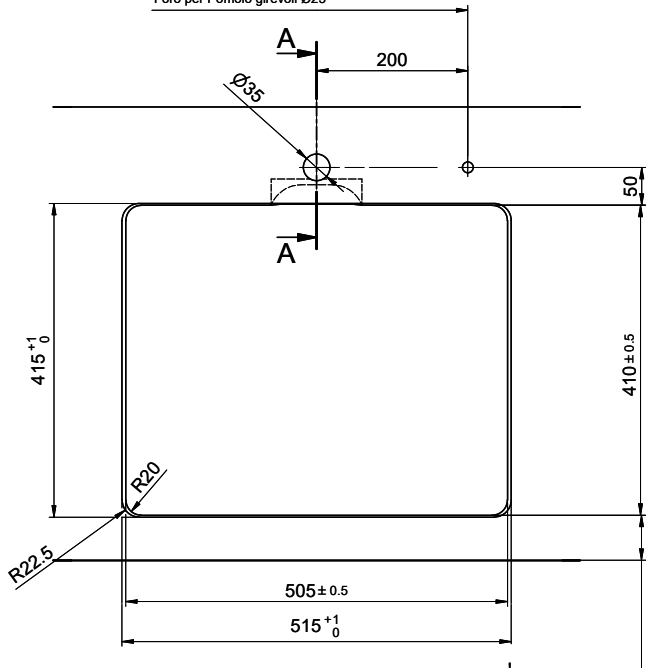

min. 60mm bei stehender Traverse.  
 min. 80mm bei liegender Traverse.

min. 60mm avec traverse debout.  
 min. 80mm avec traverse allongé.

min. 60mm con traversa stante.  
 min. 80mm con traversa coricata.

Für 12mm Arbeitsplatte.  
 Pour plan de travail de 12mm.  
 Per piano di lavoro da 12mm.

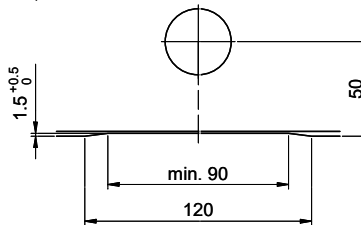

A-A (1 : 2)

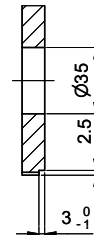

Für 13 - 30mm Arbeitsplatte.  
 Pour plan de travail de 13 - 30mm.  
 Per piano di lavoro da 13 - 30mm.

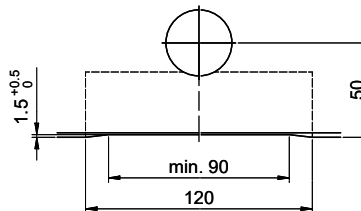

A-A (1 : 2)

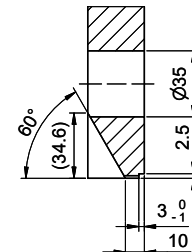

Für 13 - 50mm Arbeitsplatte.  
 Pour plan de travail de 13 - 50mm.  
 Per piano di lavoro da 13 - 50mm.

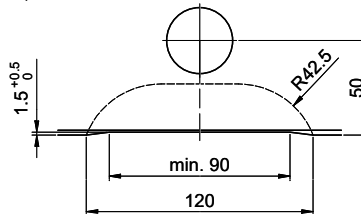

A-A (1 : 2)

