

Für 12mm Arbeitsplatte.
 Pour plan de travail de 12mm.
 Per piano di lavoro da 12mm.

X (1:2)

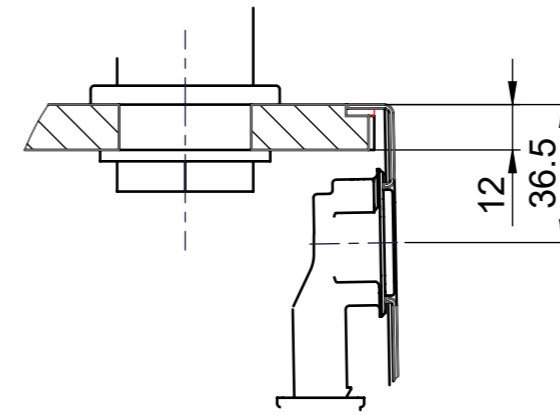

Y (1:2)

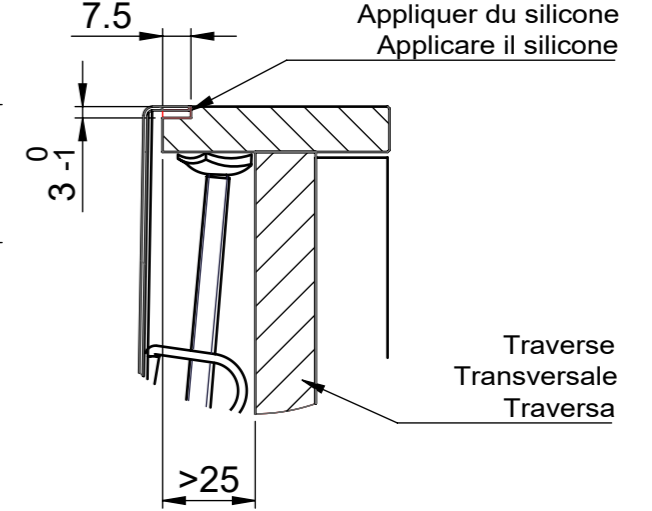

Für 13 - 30mm Arbeitsplatte.
 Pour plan de travail de 13 - 30mm.
 Per piano di lavoro da 13 - 30mm.

X (1:2)

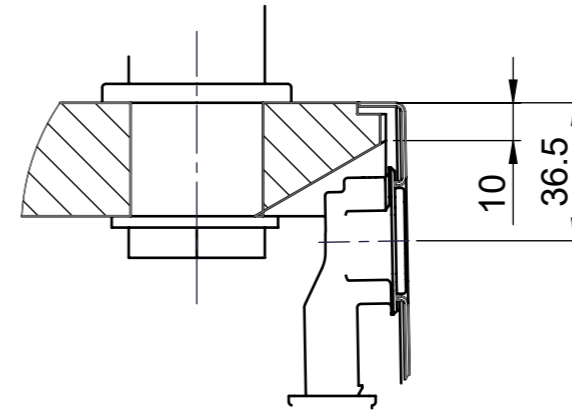

Y (1:2)

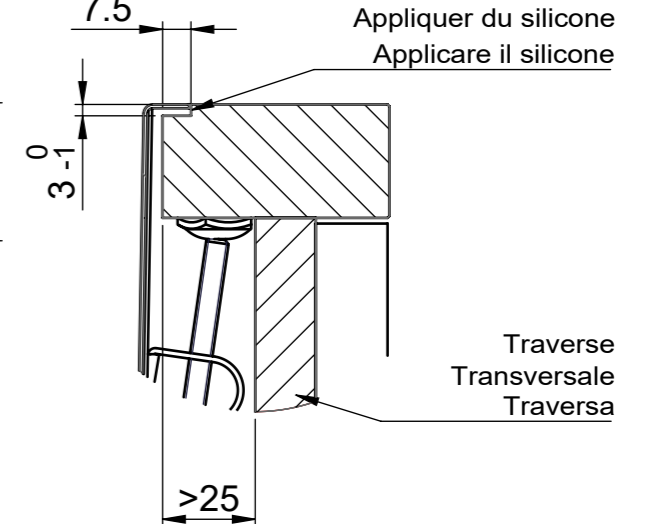

Für 13 - 50mm Arbeitsplatte.
 Pour plan de travail de 13 - 50mm.
 Per piano di lavoro da 13 - 50mm.

X (1:2)

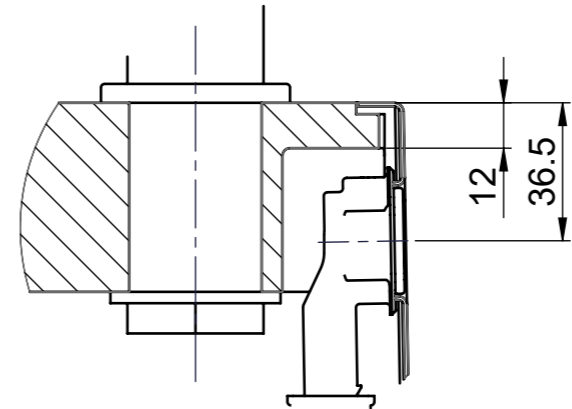

Y (1:2)

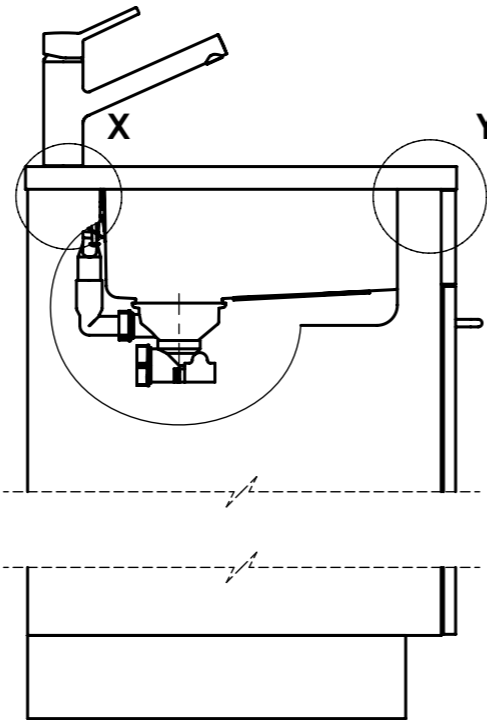
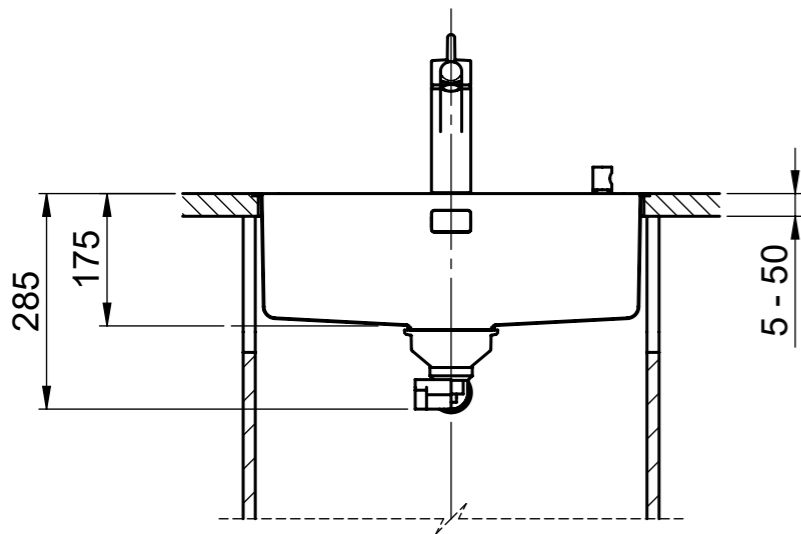
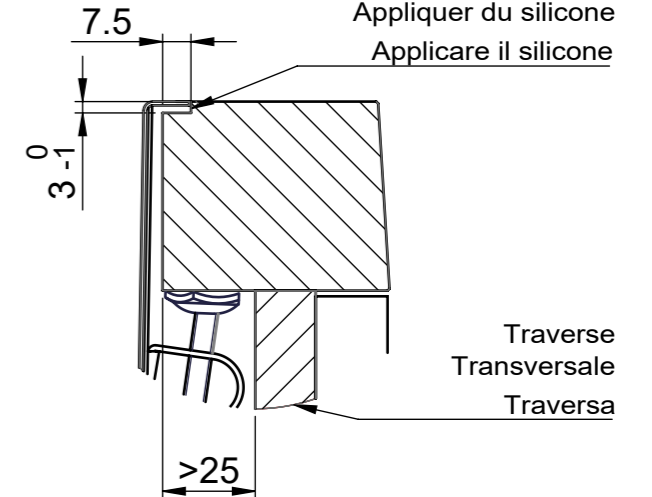

Bei der Planung die Traverse im Möbel beachten!

Faites attention à la barre transversale dans les meubles lors de la planification!

Presta attenzione alla traversa nei mobili durante la pianificazione!

Vom flächenbündigen Einbau in beschichteten Spanplatten raten wir ab.
 Nous vous déconseillons le montage à fleur sur des panneaux de particules enduits.
 Sconsigliamo il montaggio a filo top in pannelli di truciolato laminato.

Bohrung für Zug- und Druckknöpfe $\varnothing 14$
 Bohrung für Drehknopf $\varnothing 25$

Trou pour boutons et Poussoirs de commande $\varnothing 14$
 Trou pour bouton rotatif $\varnothing 25$

Foro per Pomelli tiranti e Pomelli pulsanti $\varnothing 14$
 Foro per Pomolo girevoli $\varnothing 25$

Für 12mm Arbeitsplatte.
 Pour plan de travail de 12 mm.
 Per piano di lavoro da 12 mm.

A-A (1 : 2)

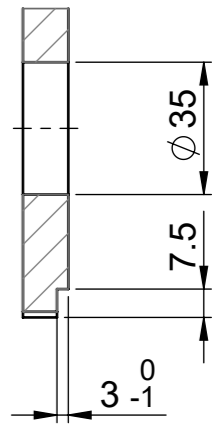
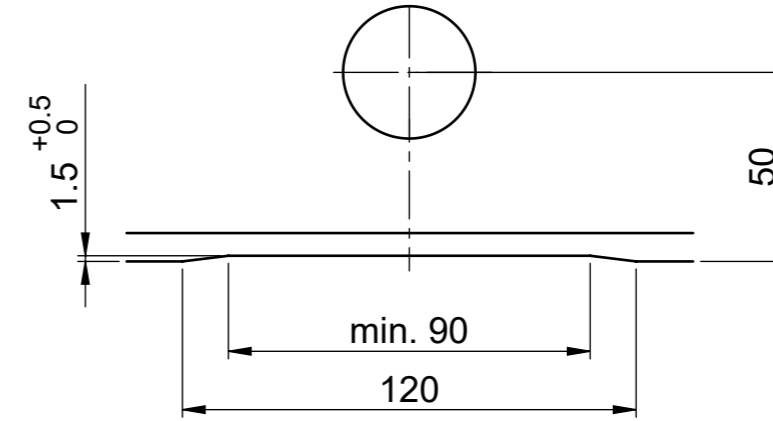

Für 13 - 30mm Arbeitsplatte.
 Pour plan de travail de 13 - 30mm.
 Per piano di lavoro da 13 - 30mm.

A-A (1 : 2)

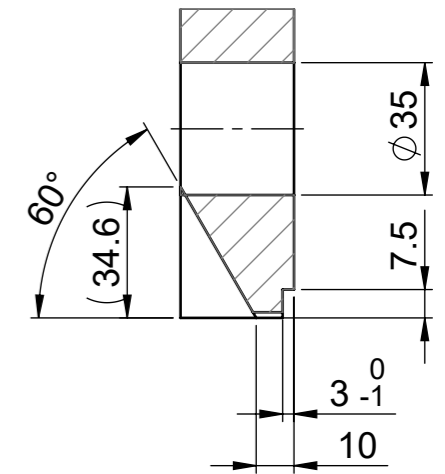
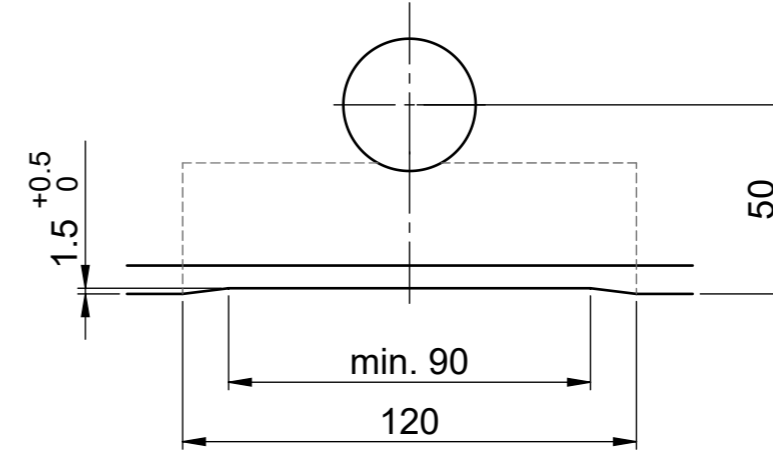

Für 13 - 50mm Arbeitsplatte.
 Pour plan de travail de 13 - 50mm.
 Per piano di lavoro da 13 - 50mm.

A-A (1 : 2)

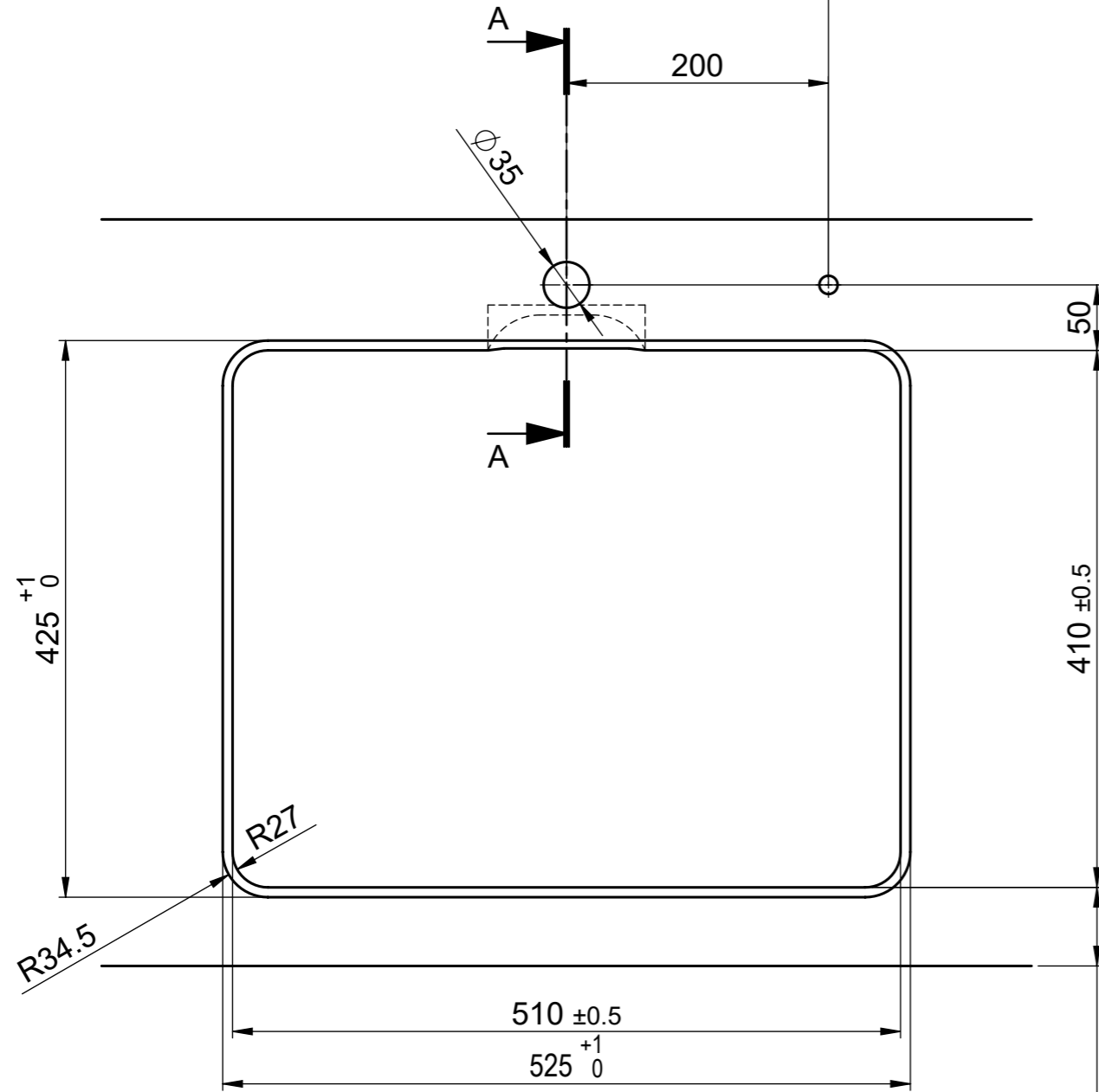
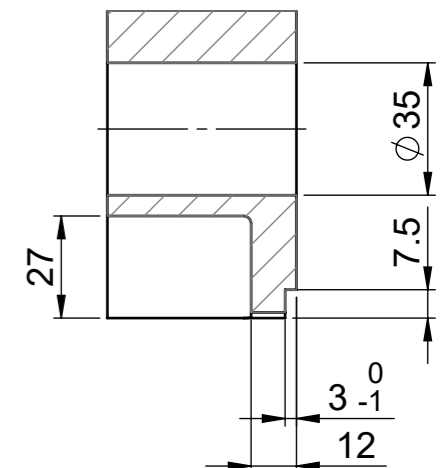
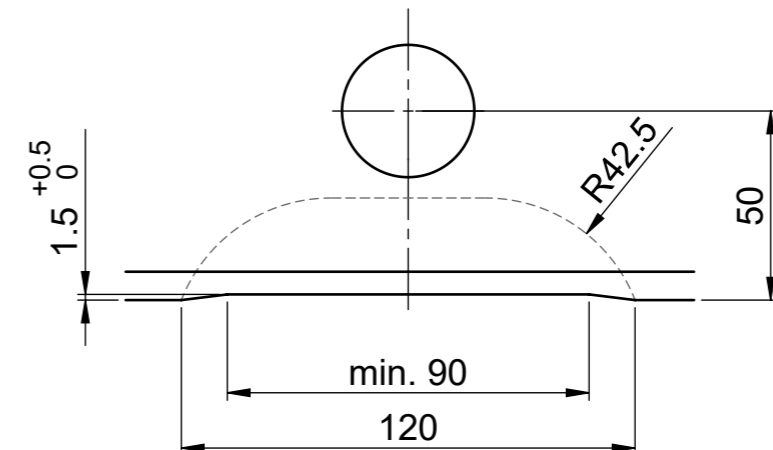

! min. 60mm bei stehender Traverse
 min. 80mm bei liegender Traverse

min. 60mm avec traverse debout
 min. 80mm avec traverse allongé

min. 60mm con traversa stante
 min. 80mm con traversa coricata

Bohrung für Zug- und Druckknöpfe $\varnothing 14$
 Bohrung für Drehknopf $\varnothing 25$

Trou pour boutons et Poussoirs de commande $\varnothing 14$
 Trou pour bouton rotatif $\varnothing 25$

Foro per Pomelli tiranti e Pomelli pulsanti $\varnothing 14$
 Foro per Pomolo girevoli $\varnothing 25$

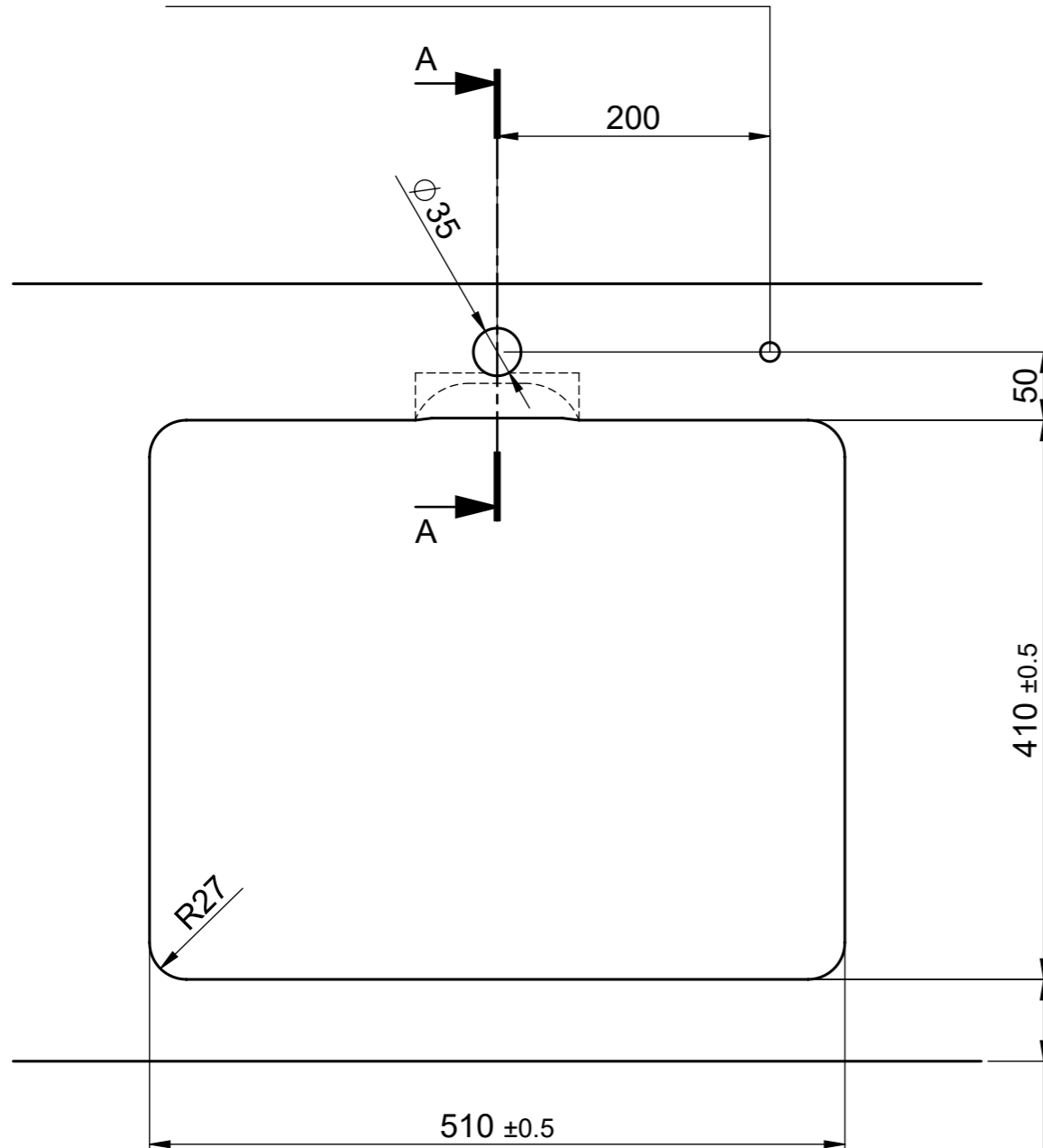

!
 min. 60mm bei stehender Traverse
 min. 80mm bei liegender Traverse
 min. 60mm avec traverse debout
 min. 80mm avec traverse allongé
 min. 60mm con traversa stante
 min. 80mm con traversa coricata

Für 12mm Arbeitsplatte.
 Pour plan de travail de 12 mm.
 Per piano di lavoro da 12 mm.

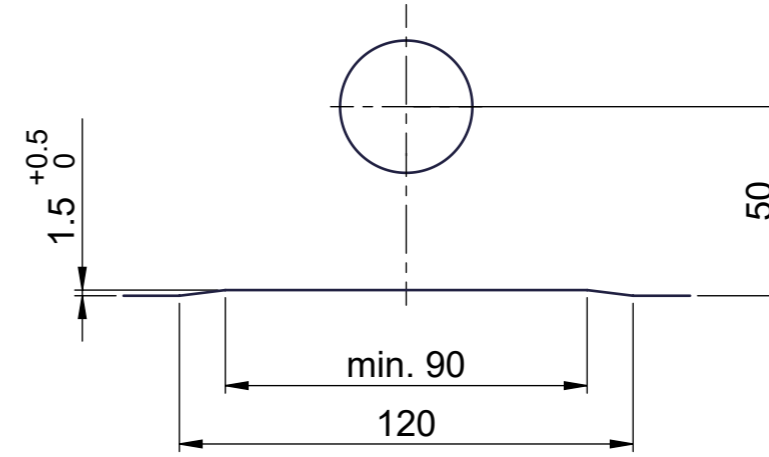

A-A (1 : 2)

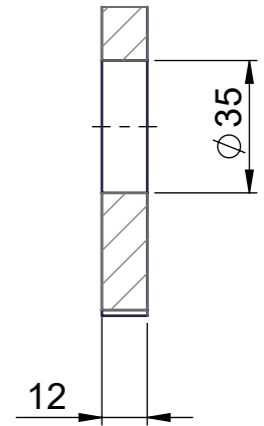

Für 13 - 30mm Arbeitsplatte.
 Pour plan de travail de 13 - 30mm.
 Per piano di lavoro da 13 - 30mm.

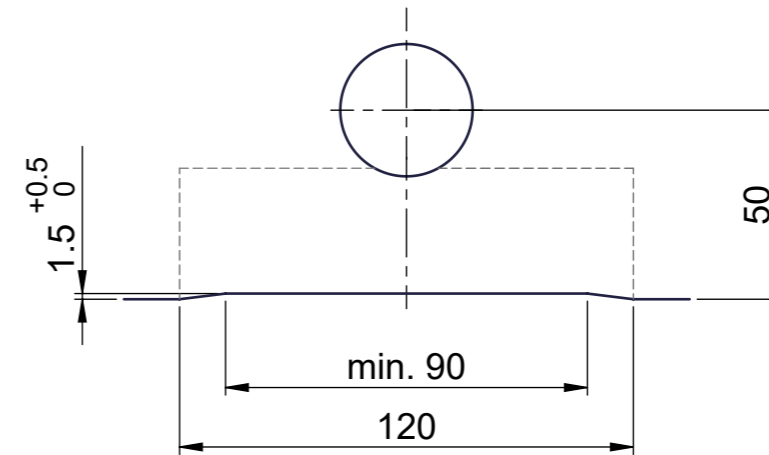

A-A (1 : 2)

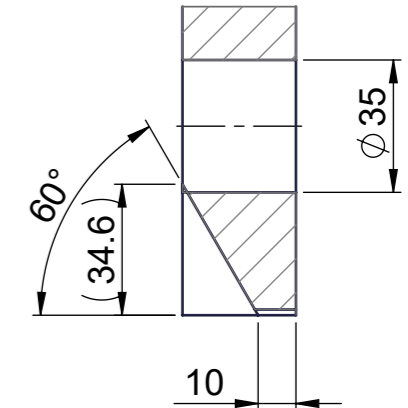

Für 13 - 50mm Arbeitsplatte.
 Pour plan de travail de 13 - 50mm.
 Per piano di lavoro da 13 - 50mm.

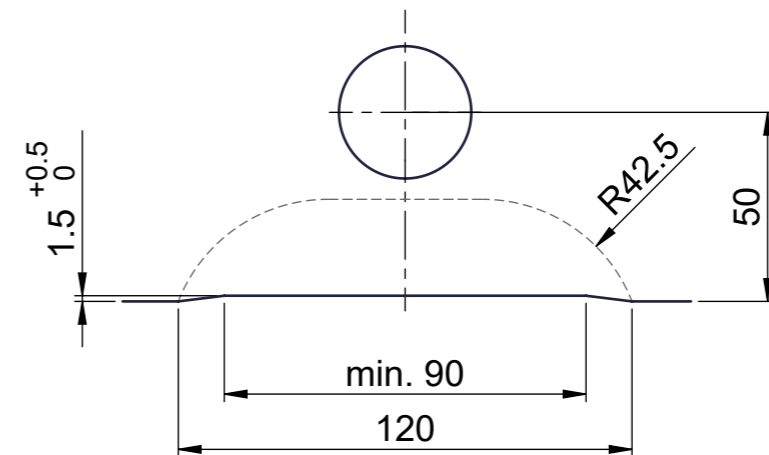

A-A (1 : 2)

