

Ö>|ÁFG { ÁÖä^ä } |ä€€É  
 Ú[~|Á|ä } Á^Á|ä€€Á^ÁFG { É  
 Ú^|Á ä } | Áä€€| | | Áä€€FG { É

YÄFÁGÁD

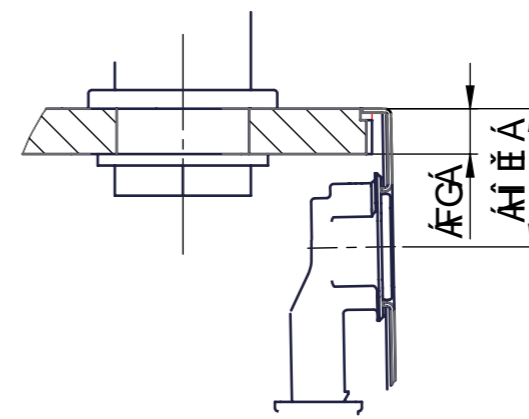

Ö>|ÁFHÄ€ { ÁÖä^ä } |ä€€É  
 Ú[~|Á|ä } Á^Á|ä€€Á^ÁFHÄ€ { É  
 Ú^|Á ä } | Áä€€| | | Áä€€FHÄ€ { É

YÄFÁGÁD

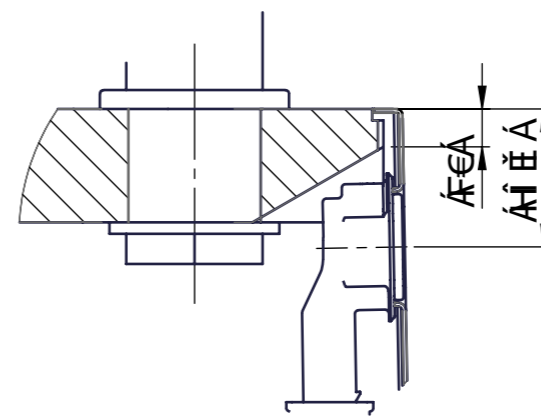

Ö>|ÁFHÄ€ { ÁÖä^ä } |ä€€É  
 Ú[~|Á|ä } Á^Á|ä€€Á^ÁFHÄ€ { É  
 Ú^|Á ä } | Áä€€| | | Áä€€FHÄ€ { É

YÄFÁGÁD

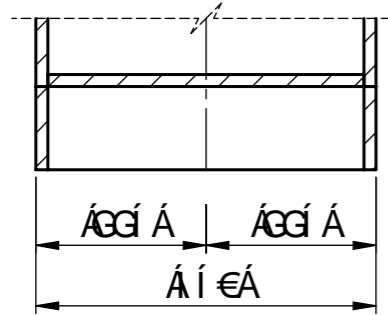
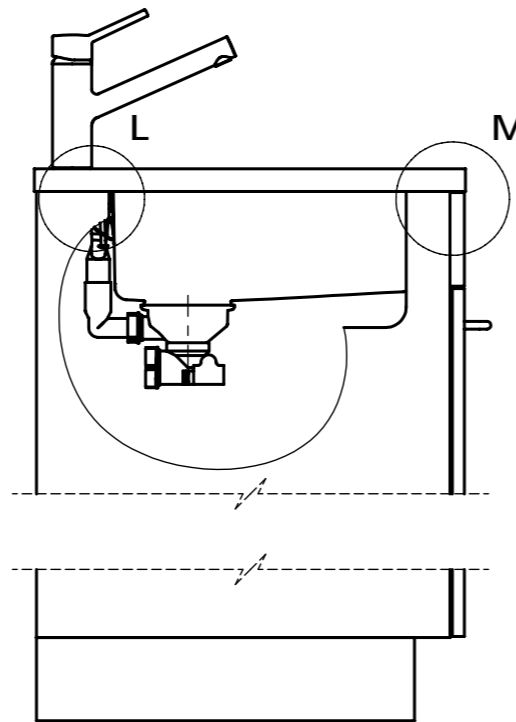
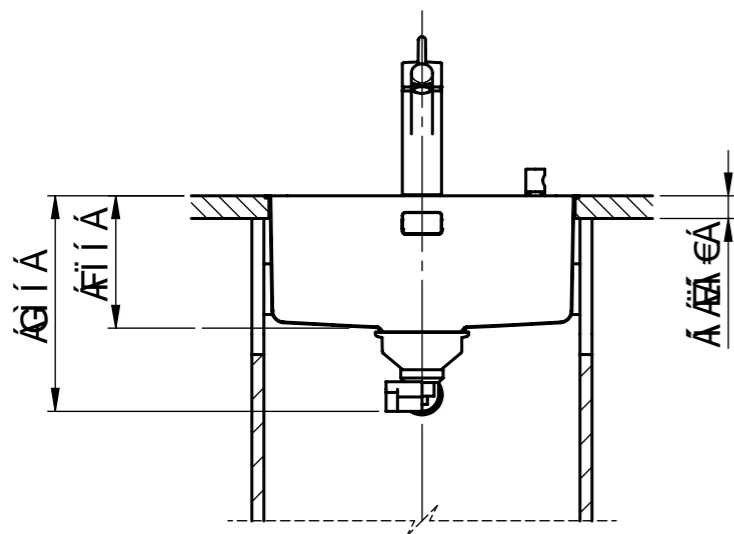
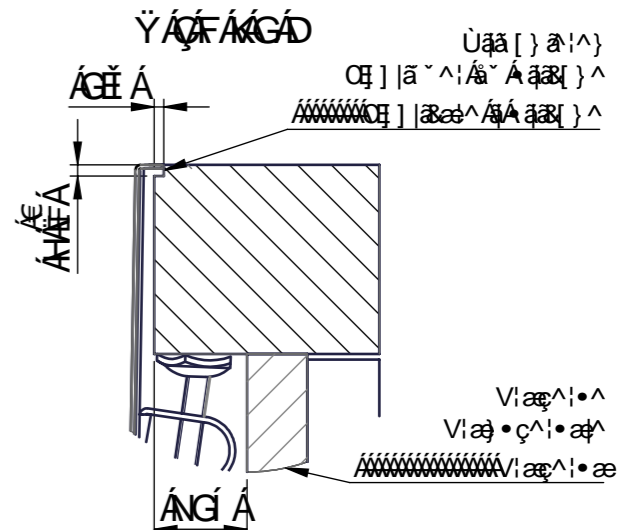
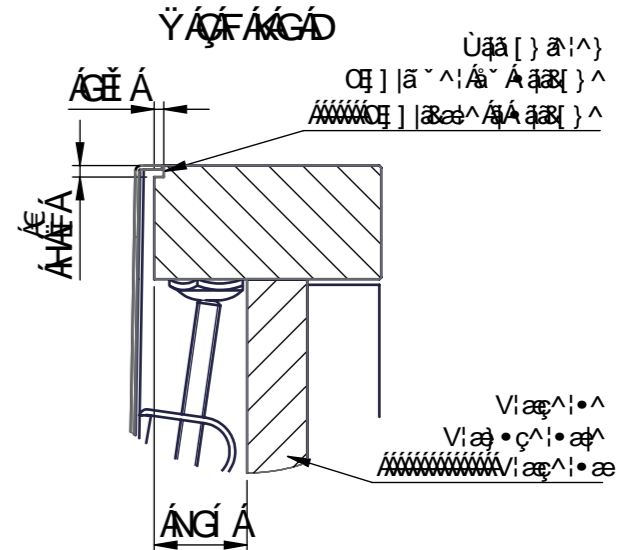
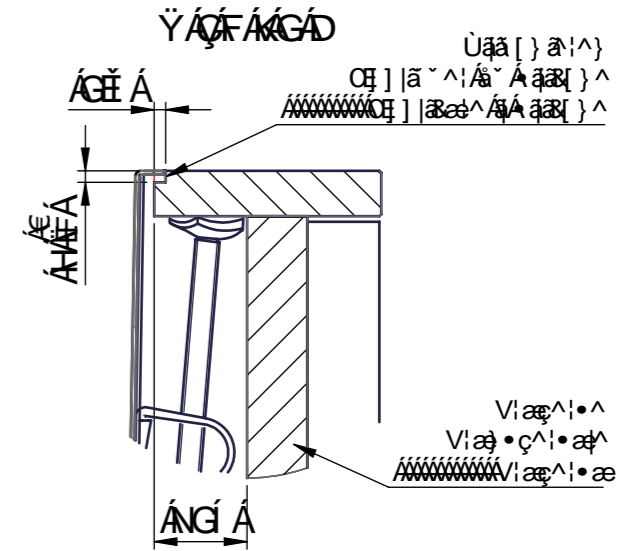
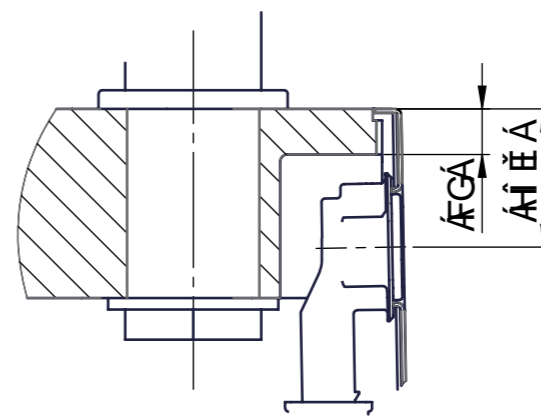

Ö^ä€^|Á|ä } \* Áä^Á|ä€€^|•^/Á 4ä^|  
 ä^ä€€^|Á

Öä€^•Áä€€^| } Ö[ ] |ä^~^|Á^Áä€€[ } ^  
 ää€€^|•^Á^~^|•^| | | Á^Áä€€[ ] ää€€ä€€^|Á

Ú|^•Öä€€^| : ä^|Á|ä€€^|•^/Áä€€^| | ää€€  
 ä^|ä€€^| | | Áä€€ä€€^|Á

X[ { Á€€&@ } ä> } ää^| ÁÖä ää€€ Á^•&€€^| } Á|ä } |ä€€^| Áä€€^| Á ä^Áä€€É  
 P[~^|Á|ä } Á^Á|ä€€Á^ÁFHÄ€ { É  
 Ú[~^|Á|ä } Á^Á|ä€€Á^ÁFHÄ€ { É

