



**SUTER**

Gültig ab:  
1. März 2026  
Valido dal:  
1° marzo 2026

**2026**

# Preisbuch | Catalogo prezzi

Preisbuch | Planungshandbuch Edelstahl-Massanfertigungen

Catalogo prezzi | Manuale di progettazione soluzioni a misura in acciaio inox

**suter.ch**

The logo for SUTER, consisting of the word "SUTER" in white, uppercase, sans-serif font, centered within a blue rounded rectangle.

# Schweizer Handwerk für die Küche – unsere Leidenschaft kennt keine Grenzen. Artigianato svizzero per la cucina – la nostra passione non conosce confini.

Unsere Leidenschaft gilt hochwertigen Edelstahl-Arbeitsplatten, Spülen, Becken, mit einer innovativen Ab- und Überlauftechnik und passenden Armaturen. Als Edelstahlspezialist im Premiumsegment verbinden wir Schweizer Handwerk mit innovativer Technik und ausgeprägter Serviceorientierung. Persönliche Beratung, technische Kompetenz und verlässliche Prozesse machen uns zu einem geschätzten Partner für anspruchsvolle Kunden, die kompromisslose Qualität, Planbarkeit, Designfreiheit und smarte Technik schätzen.

La nostra passione sono i piani di lavoro in acciaio inox e i lavelli di alta qualità, con un'innovativa tecnologia di scarico e troppopieno e rubinetteria più adatta. In qualità di specialisti dell'acciaio inox nel segmento premium, coniughiamo l'artigianato svizzero con una tecnologia innovativa e un forte orientamento al servizio. Consulenza personalizzata, competenza tecnica e processi affidabili ci rendono un partner apprezzato dai clienti esigenti che ricercano qualità senza compromessi, pianificabilità, libertà di progettazione e tecnologia intelligente.



#### **Werbemittelbestellung**

Bestellen Sie unsere Preisbücher sowie Broschüren und Magazine auch online unter [suter.ch](http://suter.ch) oder per Email unter: [werbemittelversand@suter.ch](mailto:werbemittelversand@suter.ch)

#### **Ordine di materiale pubblicitario**

Ordinate i nostri cataloghi prezzi, opuscoli e riviste anche online su [suter.ch](http://suter.ch) o per e-mail all'indirizzo: [werbemittelversand@suter.ch](mailto:werbemittelversand@suter.ch)

---

Alle aufgeführten Preise verstehen sich in CHF exkl. MWST / inkl. 8.1% MWST und als unverbindliche Preisempfehlung. Die vorgezogene Recyclinggebühr (VRG) ist jeweils separat exkl. MWST angegeben. Alle aktuellen Informationen sowie die Allgemeinen Geschäftsbedingungen finden Sie unter [suter.ch](http://suter.ch).

Tutte le indicazioni di prezzo devono intendersi in CHF, IVA escl./incl. 8.1% e come prezzi consigliati non vincolanti. La tassa di riciclaggio anticipata (TRA) è sempre indicata separatamente senza IVA. Tutte le informazioni aggiornate e le Condizioni generali di vendita sono consultabili su [suter.ch](http://suter.ch).

Irrtümer, Druckfehler und technische Änderungen vorbehalten | Stand 01.2026 / Con riserva di errori, errori di stampa e modifiche tecniche | Stato al 01.2026

Schweizer Familienunternehmen  
und Produktion 4  
Impresa di famiglia e produzione svizzere



Schweizer Familienunternehmen  
Impresa svizzera di famiglia

Planungshandbuch  
Edelstahl-Massanfertigungen 16  
Manuale di progettazione  
soluzioni a misura in acciaio inox



Massanfertigungen  
Soluzioni a misura

Unterbau-Becken 128  
Lavelli sottopiano



Unterbau-Becken  
Lavelli sottopiano

Flächenbündige-Spülen/  
Flachrand-Spülen 210  
Lavelli a filo top/  
Lavelli sopra piano



IF-Spülen  
IF-Lavelli

Einlege-Spülen 294  
Lavelli da incasso



Einlege-Spülen  
Lavelli da incasso

Küchenzubehör 310  
Accessori per cucina



Küchenzubehör  
Accessori per cucina

Armaturen 318  
Rubinetteria

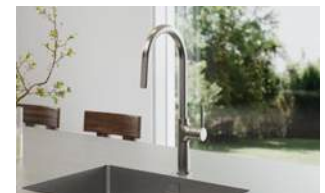

Armaturen  
Rubinetteria

Dispenser/Zugknöpfe 362  
Distributori/Pomoli



Dispenser/Zugknöpfe  
Distributori/Pomoli

Abfall-Systeme 370  
Sistemi di raccolta rifiuti



Abfall-Systeme  
Sistemi di raccolta rifiuti



Alfred Suter Senior  
Alfred Suter Senior



V.l.n.r.: Alfred Suter, Eveline Stutz-Suter und Marco Suter  
Da sx a dx: Alfred Suter, Eveline Stutz-Suter e Marco Suter

## Schweizer Handwerk für die Küche – unsere Leidenschaft kennt keine Grenzen. Artigianato svizzero per la cucina – la nostra passione non conosce confini.

### Faszination für die Küche – damals ...

Die Erfolgsgeschichte der Suter Inox AG beginnt 1947 mit der Gründung durch Alfred Suter Senior. Erste Produkte sind Milchkannen aus rostfreiem Stahl. 1952 erfolgt die Konzentration auf die Fertigung von Spülen aus Edelstahl. Mit visionären Konzepten für Wasserzentren, später auch mit Edelstahl-Massanfertigungen, etabliert Suter Inox seine Küchenkompetenz und trägt zu einer komfortableren und gehobeneren Küchenkultur bei.

### Il fascino per la cucina: allora ...

La storia di successi di Suter Inox AG inizia nel 1947 con la fondazione dell'azienda da parte di Alfred Suter senior. I primi prodotti sono bidoni per il latte in acciaio inox. Nel 1952, l'attività si concentra sulla produzione di lavelli in acciaio inox. Con progetti visionari di punti idrici e successivamente anche con soluzioni su misura in acciaio inox, Suter Inox è andata aermando la propria competenza in materia di cucine e contribuendo a una cultura della cucina più confortevole e sofisticata.

### ... wie heute.

Um eine kontinuierliche Weiterentwicklung zu gewährleisten, bauen wir das Unternehmen stetig mit viel Elan und Passion weiter aus. Unser Hauptaugenmerk gilt der Weiter- und Neuentwicklung unserer innovativen Produkte, die an unserem Standort mit modernsten Anlagen und aktuellsten Technologien gefertigt werden. Mit Herz und Leidenschaft investieren wir täglich in unsere Geschäftsbeziehungen – in unsere langjährigen Partner, treuen Kunden und Mitarbeiter.

### ... come oggi.

Per garantire un continuo sviluppo, espandiamo costantemente l'azienda con molto entusiasmo e passione. Il nostro obiettivo principale è quello di sviluppare e riprogettare i nostri prodotti innovativi, che vengono fabbricati presso la nostra sede utilizzando impianti, tecnologie e sistemi operativi all'avanguardia. Ogni giorno investiamo con cuore e passione nelle nostre relazioni commerciali: nei nostri partner di lunga data, nei nostri clienti fedeli e nei nostri dipendenti.

# Schweizer Qualität mit Verantwortung

## Qualità svizzera con responsabilità

Seit über 75 Jahren fertigen wir unsere Produkte am Firmensitz in Schinznach-Bad. Schweizer Qualität ist für uns kein Label, sondern ein Versprechen: regionale Fertigung, transparente Herkunft der Rohstoffe und eine Produktion, die echte Schweizer Werte verkörpert – Tradition, Beständigkeit, höchste Qualität und Präzision.

Unsere Nähe zur Natur – direkt am Naturschutzgebiet an der Aare – verpflichtet uns zu einem schonenden Umgang mit Ressourcen. Wir erhalten Bewährtes, entwickeln mit Innovationskraft Neues und legen dabei stets Wert auf Ästhetik, Design und ökologische Verantwortung.

Mit einem Produkt von Suter wählen Sie langlebige Qualität, die Umwelt und Mensch gleichermaßen respektiert. So leisten wir gemeinsam einen Beitrag für kommende Generationen.

Da oltre 75 anni realizziamo i nostri prodotti nella sede di Schinznach-Bad. Per noi la qualità svizzera non è un marchio, ma una promessa: manifattura regionale, provenienza trasparente delle materie prime e una produzione che incarna i veri valori svizzeri – tradizione, costanza, massima qualità e precisione.

La nostra vicinanza alla natura, direttamente nel cuore della riserva naturale lungo le sponde dell'Aar, ci impegna a un uso rispettoso delle risorse. Manteniamo ciò che è collaudato, sviluppiamo nuovi prodotti con forza innovativa e attribuiamo sempre grande importanza all'estetica, al design e alla responsabilità ecologica.

Acquistando un prodotto Suter, si sceglie una qualità duratura che rispetta sia l'ambiente che le persone. In questo modo contribuiamo insieme al benessere delle generazioni future.



### Photovoltaik

Mit unserer Photovoltaik-Anlage betreiben wir u.a. unsere Fertigung am Produktionsstandort Schinznach-Bad.

### Fotovoltaico

Il nostro impianto fotovoltaico ci permette, fra le varie cose, di alimentare il nostro reparto di produzione nello stabilimento di Schinznach-Bad.



### Klimaschutz

Teilnahme am Programm der Energie-Agentur der Wirtschaft zur Reduktion der CO<sub>2</sub>-Emissionen und Optimierung der Energieeffizienz.

### Protezione climatica

Partecipando al programma dell'Agenzia dell'energia per l'economia, ci adoperiamo per ridurre le emissioni di CO<sub>2</sub> e ottimizzare l'efficienza energetica.



### Stromsparen

Durch stetige Investitionen in unsere Produktion optimieren wir unseren Stromverbrauch kontinuierlich.

### Risparmio energetico

Investendo costantemente nella nostra produzione, ottimizziamo su base continuativa il nostro consumo di energia.



### Umwelt schonen

Wir beziehen unsere Ressourcen aus verantwortungsvollen Quellen.

### Protezione dell'ambiente

Le nostre risorse provengono da fonti responsabili.



### Langlebigkeit fördern

Unsere Produkte sind so konstruiert, dass sie Ihnen langfristig und somit nachhaltig Freude bereiten.

### Promozione della durevolezza

I nostri prodotti sono progettati per offrirvi un piacere duraturo e quindi sostenibile.

Regionale Fertigung in Schinznach-Bad an der Aare  
Produzione regionale a Schinznach-Bad sulle rive del fiume Aar



# Unser Engagement für morgen

## Il nostro impegno per il domani

Alle Green Line Produkte  
sind ausgezeichnet mit  
Tutti i prodotti Green Line  
sono contrassegnati con



### Bis zu 92% weniger CO<sub>2</sub>, 100% Edelstahl – für Küchen, die die Zukunft im Blick haben

Ein wesentlicher Bestandteil ist der Einsatz von Edelstahl mit einem bis zu 92% geringeren CO<sub>2</sub>-Fussabdruck. Dies gelingt durch die Verwendung von CO<sub>2</sub>-armer Elektrizität bei der Produktion und dem Einsatz von CO<sub>2</sub>-armen Rohstoffen, wie zum Beispiel recycelten Stahl. Damit trägt dieser Edelstahl erheblich zur Verringerung des ökologischen Fussabdrucks bei.

### Fino al 92% di CO<sub>2</sub> in meno, 100% acciaio inox: per le cucine che guardano al futuro

Componente fondamentale è l'uso di acciaio inox con un'impronta di CO<sub>2</sub> inferiore fino al 92%. Ciò è possibile grazie all'impiego di elettricità a basse emissioni di CO<sub>2</sub> per quanto riguarda la produzione e l'utilizzo di materie prime a basse emissioni di CO<sub>2</sub>, come ad esempio l'acciaio riciclato. Questo acciaio inox contribuisce quindi in modo significativo a ridurre l'impronta ecologica.





### Green Line Edelstahl

Schont die Ressourcen und damit die Umwelt. Der eingesetzte Edelstahl übertrifft sogar die Vorgaben des Minergie-Eco-Standards.

### Green Line acciaio inox

Rispetta le risorse e quindi l'ambiente. L'acciaio inox utilizzato supera addirittura i requisiti dello standard Minergie-Eco.



suter.ch/green-line



### Nachhaltige Spanplatte

Kombiniert wird der Green Line Edelstahl für die Arbeitsplatten mit innovativen, und lösemittelfreien Verklebungen d.h. die Spanplatte wird mit biobasierten Klebstoffen verleimt und ist mit dem Label «Schweizer Holz» zertifiziert.

### Pannello in truciolato sostenibile

L'acciaio inox Green Line per i piani di lavoro è combinato con un incollaggio innovativo e privo di solventi, ovvero il pannello in truciolato è incollato con adesivi a base biologica ed è certificato con il marchio «Legno svizzero».



### Emissionsfreie Verklebungen

Die Edelstahl-Oberfläche wird mit der Spanplatte lösemittelfrei verklebt, was nicht nur die Anforderungen von Minergie-Eco erfüllt, sondern auch die Raumluftqualität schützt.

### Incollaggio senza emissioni

La superficie in acciaio inox è incollata al pannello in truciolato priva di solventi, il che non solo soddisfa i requisiti Minergie-Eco, ma protegge anche la qualità dell'aria interna.



### Langlebigkeit und Qualität

Die Green Line Arbeitsplatte basiert auf robuster Konstruktion und hochwertiger Verarbeitung. Die hohe Qualität garantiert eine lange Lebensdauer.

### Durevolezza e qualità

Il piano di lavoro Green Line si basa su una struttura robusta e una lavorazione di elevato pregio. L'alta qualità garantisce una lunga durata.



### Regionale Fertigung

Die regionale Verarbeitung sorgt für die Wertschöpfung am Standort in der Schweiz und kurze Transportwege. Das ist auch gut für die Umwelt.

### Produzione regionale

La produzione regionale garantisce valore aggiunto in Svizzera e percorsi di trasporto brevi: un vantaggio anche per l'ambiente.

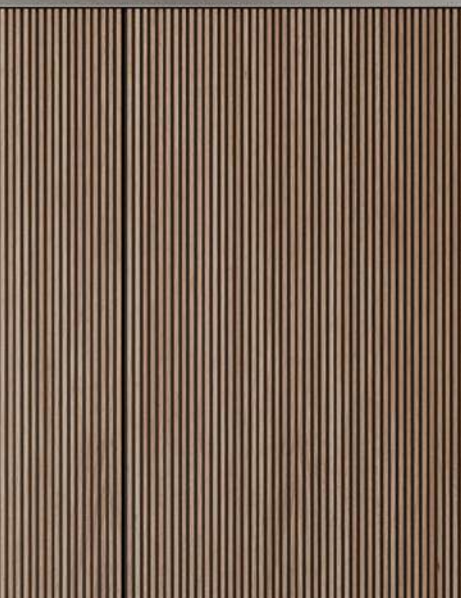

### Ausgezeichnet

Unsere Produktausführung Green Line trägt jetzt das ecobau-Zertifikat eco2 – ein starkes Qualitätsversprechen für nachhaltige und gesundheitlich geprüfte Baustoffe. Damit erfüllen wir die neuesten und erweiterten Anforderungen der Prüfmethodik 2025 des Vereins ecobau und setzen damit ein deutliches Zeichen für verantwortungsbewusstes Bauen. Dank dieser Zertifizierung eignen sich unsere Produkte für Minergie-ECO-Projekte – und schaffen echten Mehrwert für nachhaltige Bauqualität.

### Certificazione

La nostra versione del prodotto Green Line ha ottenuto la certificazione ecobau eco2, una garanzia di qualità importante a favore di materiali da costruzione sostenibili e salubri. In questo modo soddisfiamo i requisiti più recenti e ampliati della metodologia di prova 2025 dell'associazione ecobau e diamo un chiaro segnale a favore di un'edilizia responsabile. Grazie a questa certificazione, i nostri prodotti sono per i progetti Minergie-ECO e, inoltre, creano un vero valore aggiunto per la qualità sostenibile delle costruzioni.

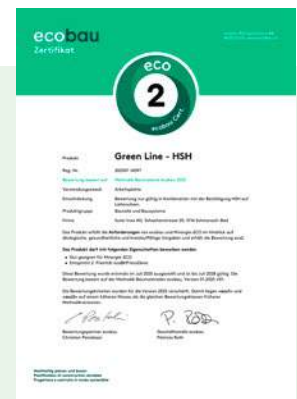

Mehr Informationen zu unserem Label:  
Maggiori informazioni sul nostro marchio:





## Das Kundenerlebnis steht im Zentrum

In unseren Filialen mit Ausstellung fügt sich alles in modernem Ambiente zusammen – dort zeigen wir unsere Kompetenz in Edelstahl, von massgefertigten Arbeitsplatten über Spülen bis hin zu innovativen Wasserplatzlösungen. Unsere Mitarbeitenden stehen Ihnen auch ausserhalb der Öffnungszeiten zur Verfügung und freuen sich auf Ihren nächsten Besuch. Buchen Sie Ihren Beratungstermin bequem und schnell telefonisch.

## Diamo grande importanza all'esperienza del cliente

Nelle nostre filiali con showroom, tutto si fonde in un ambiente moderno: qui mostriamo la nostra competenza nell'acciaio inox, dai piani di lavoro su misura ai lavelli, fino alle innovative soluzioni per il punto idrico. Il nostro personale è disponibile anche al di fuori degli orari di apertura e sarà lieto di darvi il benvenuto in occasione della vostra prossima visita. Prenotate la vostra prossima consulenza in modo comodo e veloce per telefono.



### Hauptsitz, Produktionsstandort und Ausstellung Schinznach-Bad

Sede centrale, sito di produzione e esposizione Schinznach-Bad  
Schachenstrasse 20  
CH-5116 Schinznach-Bad  
T +41 58 263 64 00



### Filiale und Ausstellung Zürich

Filiale e esposizione di Zurigo  
Hardturmstrasse 125  
CH-8005 Zürich  
T +41 58 263 64 02



### Filiale und Ausstellung Crissier

Filiale e esposizione di Crissier  
Chemin des Lentillières 5g  
CH-1023 Crissier  
T +41 58 263 64 03



suter.ch/service

## Starke Vorteile für starke Partner

Wir sind der Edelstahlspezialist mit innovativen Lösungen. Mit unseren kompetenten Services und Dienstleistungen unterstützen wir bei jedem Schritt. Egal ob Sie Unterstützung beim Ausmessen Ihrer Edelstahl-Massanfertigung, ein Ersatzteil oder weitere Informationen zu Ihrem Produkt benötigen – wir geben alles, um die Zufriedenheit mit bester Beratung und hochwertigen Produkten sicherzustellen.

## Vantaggi concreti per partner forti

Siamo gli specialisti dell'acciaio inox nel segmento premium con soluzioni innovative. Con i nostri servizi competenti, vi forniamo assistenza in ogni singola fase. Se avete bisogno di assistenza per misurare la vostra cucina, di un pezzo di ricambio o di ulteriori informazioni sul vostro prodotto, facciamo tutto il possibile per garantire la vostra soddisfazione con la migliore consulenza e prodotti di elevata qualità.



### Premiumqualität & Innovation

Hochwertige Edelstahl-Arbeitsplatten, Spülen und Wasserplatzlösungen mit einzigartigem Design und innovativen Funktionen.

### Qualità premium e innovazione

Lavelli, soluzioni per il punto idrico e piani di lavoro in acciaio inox di alta qualità con un design unico e funzioni innovative.



### Schweizer Präzision & Verlässlichkeit

Jahrzehntelange Erfahrung, exakte Verarbeitung und Termintreue machen Suter zum verlässlichen Partner im Premiumsegment.

### Precisione e affidabilità svizzera

Esperienza decennale, lavorazioni accurate e rispetto delle scadenze rendono Suter un partner affidabile nel segmento premium.



### Exzellenter Kundenservice & Partnerschaft

Persönliche Beratung, individuelle Projektunterstützung und schnelle Lösungen – Suter begleitet Handelspartner von der Planung bis zur Umsetzung.

### Servizio clienti eccellente e partnership

Consulenza personalizzata, assistenza individuale nei progetti e soluzioni rapide: Suter accompagna i partner commerciali dalla pianificazione alla realizzazione.



### Ausmessen und Montage vor Ort

Auf Wunsch übernehmen wir das Ausmessen und die Montage der Edelstahl-Massanfertigungen direkt vor Ort.

### Misurazioni e montaggio in loco

Su richiesta, ci occupiamo delle misurazioni e dell'installazione della vostra soluzione personalizzata in acciaio inox direttamente sul posto.

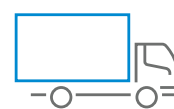

### Direktlieferung auf die Baustelle

Wir liefern Ihre Bestellung sicher, termin- und fachgerecht an die gewünschte Adresse.

### Consegna diretta a piè d'opera

Consegniamo il vostro ordine in modo sicuro, puntuale e professionale all'indirizzo desiderato.



### Servicetechniker / Serviceorganisation

Unsere erfahrenen Servicetechniker haben für Sie das passende Ersatzteil immer dabei. Und das schweizweit.

### Tecnici dell'assistenza / organizzazione di assistenza

I nostri tecnici dell'assistenza esperti hanno sempre con sé i pezzi di ricambio adatti per voi, in tutta la Svizzera.

# Die Vorteile von Edelstahl

Edelstahl ist mehr als nur ein Werkstoff – er ist Gestaltungspartner für moderne Küchenwelten und überzeugt dort, wo Design, Funktionalität und Nachhaltigkeit aufeinandertreffen. Auf einzigartige Weise vereint er nahezu grenzenlose Gestaltungsmöglichkeiten mit besonderen funktionalen Vorteilen und hebt so den Wohnraum auf ein nächstes Level.

## I vantaggi dell'acciaio inox

L'acciaio inox è più di un semplice materiale – stimola la creatività nella progettazione di cucine contemporanee e si impone laddove il design si coniuga con funzionalità e durata. In modo unico, offre una libertà creativa praticamente illimitata integrando caratteristiche funzionali particolari e portando così lo spazio abitativo a un livello superiore.



### Die richtige Pflege für Ihre Edelstahlprodukte

Edelstahl ist ein hochwertiges Material, das sein neuwertiges Aussehen mit der richtigen Pflege über Jahre beibehält. Für eine optimale Reinigung und Pflege bieten wir eine Auswahl an geeigneten Produkten an.

#### La cura adeguata per i vostri prodotti in acciaio inox

L'acciaio inox è un materiale di alta qualità che, con la cura adeguata, mantiene il suo aspetto nuovo per anni. Offriamo una selezione di prodotti adatti a una pulizia e manutenzione ottimali.



[suter.ch/produkte](https://suter.ch/produkte)



## Exklusives Design für die Küche

Qualität, die man sieht und spürt. Von der Edelstahl-Arbeitsplatte mit integriertem Wasserzentrum über Rückwände bis hin zu komplexen Formen setzen wir alles daran, die Visionen unserer Kunden wahr werden zu lassen. Dabei entstehen mit viel handwerklichem Geschick und der Passion für den Werkstoff Edelstahl unverwechselbare Einzelstücke von herausragender Qualität. Diese werden in Schweizer Handarbeit verarbeitet, damit sie am Schluss unseren Qualitätsanforderungen gerecht werden.

## Design esclusivo per la cucina

La qualità che si vede e che si sente. Dai piani di lavoro con punto idrico integrato e dai pannelli posteriori fino alle forme più complesse, facciamo del nostro meglio per realizzare le visioni dei nostri clienti. Tanta maestria artigianale e passione per il materiale acciaio inox danno vita a pezzi unici ed esclusivi di qualità eccellente. Molti di essi vengono levigati o lucidati a mano in Svizzera per soddisfare i nostri rigorosi requisiti qualitativi.



### Langlebig

Robust im Alltag, unkompliziert in der Pflege – Edelstahl ist besonders widerstandsfähig und behält sein gepflegtes Erscheinungsbild.

### Durevole

Robusto nell'uso quotidiano e facile da pulire – l'acciaio inox è particolarmente resistente e mantiene sempre un aspetto curato.



### Zeitlos

Schlicht, pur und gleichzeitig modern – ohne auf modische Effekte angewiesen zu sein, kombiniert sich das Material harmonisch in verschiedenste Gestaltungskonzepte.

### Senza tempo

Sobrio, puro e allo stesso tempo moderno – insensibile alle mode, questo materiale si combina armoniosamente con i più svariati concetti di design.



### Hygienisch

Für ein sicheres Gefühl – die porenfreie Oberfläche von Edelstahl sorgt für hygienische Reinheit in Ihrer Küche.

### Igienico

Una sensazione di sicurezza – la superficie non porosa dell'acciaio inox è garanzia di igiene perfetta in cucina.



### Ästhetisch

Neutral im Charakter, stark in der Wirkung – nimmt die Farben der Umgebung auf und geht ein elegantes Zusammenspiel mit unterschiedlichsten Materialien ein.

### Estetico

Un materiale neutro ma allo stesso tempo ricco di carattere – riflette i colori dell'ambiente circostante e interagisce elegantemente con gli altri materiali.



### Nachhaltig

Ressourcen schonen, Werte bewahren – mit zukunftsweisendem Edelstahl: 100 % recycelbar und aus rückverfolgbarem Ursprung.

### Sostenibile

Preservare le risorse, salvaguardare l'investimento con l'acciaio inox, il materiale del futuro: 100 % riciclabile e di origine tracciabile.



### Authentisch

Unverfälscht und vertrauenswürdig – die unveränderte Materialität des Metalls versteckt nichts, sondern zeigt sich in seiner reinen Form.

### Autentico

Originale e affidabile – il carattere immutabile del metallo non nasconde nulla, ma si mostra nella sua forma più pura.



## Ab- und Überlauftechnik – Durchdachte Lösungen für unterschiedliche Bedürfnisse.

Die Ab- und Überlauftechnik von Suter steht für eine neue Generation integrierter Lösungen, bei denen Funktion, Design und Hygiene nahtlos ineinandergreifen. Mit verdecktem Ablauf, untenliegendem Korb und intelligenten Bedienlösungen bietet Desino höchsten Komfort bei minimalistischem Erscheinungsbild. Ob manuell, mechanisch oder sensorgesteuert – alle Varianten verzichten auf sichtbare Bedienelemente auf der Arbeitsfläche und sorgen so für eine klare und aufgeräumte Optik sowie eine einfachere Reinigung. Die Funktion bleibt optisch dezent im Hintergrund – das Ergebnis: mehr Ruhe im Design, mehr Komfort im Alltag und eine besonders einfache Bedienung.

## Tecnologia di scarico e troppopieno – Soluzioni ben studiate per esigenze diverse.

La tecnologia di scarico e troppopieno di Suter rappresenta una nuova generazione di soluzioni integrate, in cui funzionalità, design e igiene si fondono perfettamente. Con scarico coperto, griglietta inferiore e varianti di comando intelligenti, Desino offre il massimo comfort con un design minimalista. Che siano manuali, meccaniche o controllate da sensori, tutte le varianti sono prive di comandi visibili sul piano di lavoro, garantendo così un aspetto pulito e ordinato e una pulizia più semplice. La funzione rimane visivamente discreta sullo sfondo, con il risultato di un design più sobrio, una maggiore praticità nella vita quotidiana e un funzionamento molto semplice.



### Desino – Die neue Eleganz im Becken.

Der Unterschied liegt im Detail: Die edle Abdeckung verdeckt den untenliegenden Korb dezent und schafft eine durchgängige, ruhige Optik im Becken. Kein sichtbares Sieb, keine Unterbrechung – ein durchgehender Beckenboden in seiner schönsten Form. Drei Positionen – offen, geschlossen und Reinigungsmodus – machen die Handhabung einfach und hygienisch.

### Desino – L'ultima novità in fatto di eleganza nei lavelli.

La differenza sta nei dettagli: l'elegante copertura nasconde con discrezione la griglietta inferiore, creando un effetto visivo uniforme e armonioso nel lavello. Nessuna griglietta visibile, nessuna interruzione: il fondo del lavello è continuo nella sua forma più bella. Tre posizioni – «aperto», «chiuso» e «pulizia» – rendono l'utilizzo semplice e igienico.



#### eFlow Desino

eFlow vereint Technologie und Design zu einem Bedienerlebnis. Die Integration erfolgt fugenlos und flächenbündig in der Beckenwand. Die drei Positionen des Ablaufs - offen, geschlossen und Reinigung – lassen sich komfortabel einstellen, ohne ins Wasser greifen zu müssen. Der Ablauf reagiert sensorgesteuert auf den Wasserstand und öffnet sich bei Bedarf automatisch. Das Ergebnis: Ein Höchstmaß an Hygiene, Sicherheit, einfacher Reinigung und eine ruhige Optik.

#### eFlow Desino

eFlow combina tecnologia e design in un'unica esperienza utente. L'integrazione avviene senza giunzioni e a filo top nella parete del lavello. Le tre posizioni dello scarico – «aperto», «chiuso» e «pulizia» – possono essere regolate comodamente senza dover immergere le mani nell'acqua. Il sistema di scarico reagisce al livello dell'acqua tramite dei sensori e, se necessario, si apre automaticamente. Il risultato: massima igiene, sicurezza, facilità di pulizia e un effetto armonioso.



#### TouchFlow Desino

TouchFlow vereint Technik und Design mit einem klaren Ziel: maximale Hygiene bei minimalem Bedienungsaufwand. Die schwenkbare Überlaufkappe dient zugleich als diskrete Touchsteuerung. Mit leichtem Druck öffnet oder schliesst sich der Ablauf, ohne ins Wasser greifen zu müssen. Zusätzliche Bedienelemente auf der Arbeitsfläche entfallen, wodurch das Küchendesign ruhig und die Reinigung einfach bleibt.

#### TouchFlow Desino

TouchFlow unisce tecnologia e design con un obiettivo chiaro: massima igiene con il minimo sforzo. Il troppopieno con placchetta a ribalta funge anche da discreto comando tattile. Con una leggera pressione, lo scarico si apre o si chiude senza dover immergere le mani nell'acqua. Non sono necessari ulteriori comandi sul piano di lavoro, conferendo così alla cucina un design sobrio e facilitandone la pulizia.



#### Raumspär Desino

Öffnen und Schliessen des Ablaufventils erfolgt über den Zug-, Druck- oder Drehknopf. Standardmässig ist eine Ausführung des Zugknopfs im Lieferumfang enthalten. Auf Wunsch kann dieser individuell passend zur Armatur und zum Dispenser ausgesucht werden.

#### Salvaspazio Desino

L'apertura e la chiusura della piletta di scarico avvengono tramite il pomolo, il pulsante o la manopola. Nel corredo di fornitura è incluso uno dei modelli di pomolo disponibili. Su richiesta, questo può essere selezionato individualmente in base alla rubinetteria e al dispenser.



#### Tipo Desino

Tipo Desino bringt manuelle Funktionalität in die elegante Welt der Desino-Technologie. Drei Positionen – offen, geschlossen und Reinigungsmodus – machen die Handhabung einfach und hygienisch. Ideal für alle, die eine durchdachte Technik und ein besonderes Design schätzen.

#### Tipo Desino

Tipo Desino introduce la funzionalità manuale nell'elegante mondo della tecnologia Desino. Tre posizioni – «aperto», «chiuso» e «pulizia» – rendono l'utilizzo semplice e igienico. Ideale per chi apprezza una tecnologia sofisticata e un design molto particolare.



## Verdeckter Überlauf mit schwenkbaren Überlaufkappe

Der verdeckte Überlauf überzeugt mit einer schwenkbaren Edelstahlkappe, die bei steigendem Wasserstand automatisch zurückklappt – ganz ohne sichtbare Öffnung. Die patentierte, magnetisch befestigte Lösung lässt sich zur Reinigung mühelos abnehmen und wieder einsetzen. Eine Innovation, die sowohl funktional als auch ästhetisch überzeugt.

#### Scarico coperto con placchetta a ribalta

Il troppopieno coperto convince grazie alla placchetta a ribalta in acciaio inox che si reclinata automaticamente quando il livello dell'acqua sale, senza lasciare alcuna apertura visibile. La soluzione brevettata con fissaggio magnetico può essere rimossa e reinserita per la pulizia. Un'innovazione convincente sia dal punto di vista funzionale che estetico.



### Obenliegendes Sieb

Der elegante Siebeinsatz überzeugt mit ansprechendem Design. Er bildet einen fast nahtlosen Übergang zum Beckenboden, was nicht nur optisch edel wirkt, sondern auch eine einfache Reinigung ermöglicht. Verfügbar in allen klassischen Ventilvarianten wie TouchFlow, Raumspar und Tipo für ausgewählte Modellreihen.

### Griglietta superiore

L'elegante griglietta presenta un design accattivante e al contempo è pratica da rimuovere. Si posiziona praticamente a filo con il fondo del lavello, con un piacevole effetto visivo, ma consente anche una facile pulizia. Disponibile in tutte le varianti di piletta classiche come TouchFlow, Salvaspazio e Tipo per linee selezionate di modelli.



### TouchFlow

TouchFlow vereint Technik und Design mit einem klaren Ziel: maximale Hygiene bei minimalem Bedienungsaufwand. Die schwenkbare Überlaufkappe dient zugleich als diskrete Touchsteuerung. Mit leichtem Druck öffnet oder schliesst sich der Ablauf, ohne ins Wasser greifen zu müssen. Zusätzliche Bedienelemente auf der Arbeitsfläche entfallen, wodurch das Küchendesign ruhig und die Reinigung einfach bleibt.

### TouchFlow

TouchFlow unisce tecnologia e design con un obiettivo chiaro: massima igiene con il minimo sforzo. Il troppopieno con placchetta a ribalta funge anche da discreto comando tattile. Con una leggera pressione, lo scarico si apre o si chiude senza dover immergere le mani nell'acqua. Non sono necessari ulteriori comandi sul piano di lavoro, conferendo così alla cucina un design sobrio e facilitandone la pulizia.



### Raumspars

Öffnen und Schliessen des Ablaufventils erfolgt über den Zug-, Druck- oder Drehknopf. Standardmässig ist eine Ausführung des Zugknopfs im Lieferumfang enthalten. Auf Wunsch kann dieser individuell passend zur Armatur und zum Dispenser ausgesucht werden.

### Salvaspazio

L'apertura e la chiusura della piletta di scarico avvengono tramite il pomolo, il pulsante o la manopola. Nel corredo di fornitura è incluso uno dei modelli di pomolo disponibili. Su richiesta, questo può essere selezionato individualmente in base alla rubinetteria e al dispenser.



### Tipo

Das obenliegende Sieb und der Stopfen bilden bei diesem Ventil eine Einheit. Durch einen sanften Druck auf den Knopf in der Mitte des Siebs wird das Ablaufventil geschlossen und durch ein leichtes Ziehen wieder geöffnet.

### Tipo

In questo sistema di piletta, la griglietta superiore e il tappo formano un'unica unità. Una leggera pressione sul pulsante nel mezzo della griglietta e una lieve trazione consentono rispettivamente di chiudere e riaprire la piletta di scarico.



### Verdeckter Überlauf

Der verdeckte Überlauf bietet ein echtes Plus an Hygiene. Die Überlaufprägung ist ohne Fugen und Kanten in die Beckenwand integriert. Die Überlaufkappe verfügt zudem über eine praktische magnetische Halterung (ausser Silver Star Varix).

### Troppopieno coperto

Pulizia e igiene sono i reali vantaggi offerti dal troppopieno coperto. L'impronta prestampata è direttamente integrata nella parete del lavello, senza fastidiosi giunti e spigoli. Il tappo per troppopieno dispone inoltre di un pratico supporto magnetico (ad eccezione di Silver Star Varix).



### Verdeckter Überlauf mit schwenkbaren Überlaufkappe

Der verdeckte Überlauf überzeugt mit einer schwenkbaren Edelstahlkappe, die bei steigendem Wasserstand automatisch zurückklappt – ganz ohne sichtbare Öffnung. Die patentierte, magnetisch befestigte Lösung lässt sich zur Reinigung mühelos abnehmen und wieder einsetzen. Eine Innovation, die sowohl funktional als auch ästhetisch überzeugt.

### Scarico coperto con placchetta a ribalta

Il troppopieno coperto convince grazie alla placchetta a ribalta in acciaio inox che si reclina automaticamente quando il livello dell'acqua sale, senza lasciare alcuna apertura visibile. La soluzione brevettata con fissaggio magnetico può essere rimossa e reinserita per la pulizia. Un'innovazione convincente sia dal punto di vista funzionale che estetico.



<b>Edelstahlspezialist</b>	
Specialista dell'acciaio inox	<b>18</b>
<b>Unsere Oberflächen</b>	
Le nostre finiture	<b>20</b>
<b>Serviceleistungen Massanfertigungen</b>	
Servizi soluzioni a misura	<b>25</b>
<b>Massanfertigungs-Formen</b>	
Forme delle soluzioni su misura	<b>26</b>
<b>Randausführungen</b>	
Bordature	<b>34</b>
<b>Beckeneinbau</b>	
Montaggio ad incasso di lavelli	<b>52</b>
<b>Kochfelder</b>	
Piani cottura	<b>53</b>
<b>Rückwände und Seitenwände</b>	
Schienali e fianchi	<b>56</b>
<b>Tablare, Fronten und Sockelbleche</b>	
Ripiani, frontali e zoccolature	<b>58</b>
<b>Ausschnitte, Schrägen und Rundungen</b>	
Intagli, tagli inclinati e curvature	<b>61</b>
<b>Verbindung von mehrteiligen Oberflächen</b>	
Giunzione di superfici composte da più parti	<b>64</b>
<b>Verbindung Crea</b>	
Giunzione Crea	<b>66</b>
<b>SolidArt</b>	
SolidArt	<b>67</b>
<b>Erdung und Masstoleranzen</b>	
Messa a terra e tolleranze dimensionali	<b>68</b>
<b>Wasserzentrum: Übersicht nach Unterschrankmassen</b>	
Panoramica punti idrici per dimensioni di base	<b>70</b>
<b>Flächenbündig eingeschweisste Becken</b>	
Lavelli termosaldati	<b>74</b>
<b>Spüleneinpressungen</b>	
Lavelli prestampati	<b>100</b>
<b>Manufaktur Tropfteile</b>	
Manifattura di scolatoi	<b>125</b>

# 1 Material 1000 Möglichkeiten / 1 materiale, 1000 possibilità

Von der massgefertigten Edelstahl-Arbeitsplatte mit integriertem Wasserzentrum über Rückwände bis hin zu komplexen Formen entsteht individuelle Küchenarchitektur in Perfektion. Hochwertiges Handwerk trifft Leidenschaft für Edelstahl – so entstehen Unikate von zeitloser Ästhetik.

Dal piano di lavoro in acciaio inox realizzato su misura con punto idrico integrato ai pannelli posteriori, fino a forme complesse: nasce un'architettura di cucina personalizzata che raggiunge la perfezione. L'artigianato di alta qualità incontra la passione per l'acciaio inox, dando vita a pezzi unici dall'estetica senza tempo.

## Individuelle Formen und Ausschnitte Forme e tagli personalizzati

Ihre Idee ist unsere Inspiration. Ob spezielle Ausschnitte, organische Formen oder ausgefallene Lösungen – wir holen das Maximum aus Edelstahl heraus. Mit Leidenschaft, Erfahrung und einem klaren Anspruch: Nichts ist unmöglich.

La vostra idea è la nostra fonte d'ispirazione. Che si tratti di tagli speciali, forme organiche o soluzioni insolite: otteniamo il massimo dall'acciaio inox. Con passione, esperienza e un obiettivo chiaro: nulla è impossibile.



## Flächenbündig eingeschweisst A filo top termosaldato

Flächenbündig eingeschweisste Becken ermöglichen stufen- und fugenlose Übergänge zwischen Arbeitsplatte und Becken.

I lavelli termosaldati a filo top consentono di unire in modo continuo il piano di lavoro e il lavello senza giunzioni.

## Tablare, Fronten Ripiani, frontali

Ob schlichte Eleganz oder komplexe Form: Unsere Fronten und Tablare aus Edelstahl entstehen mit viel Feingefühl und Know-how. Sie setzen gestalterische Akzente – und machen Ihre Küche zu einem Unikat mit Charakter.

Che si tratti di eleganza sobria o di forme complesse: i nostri frontali, zoccoli e ripiani in acciaio inox sono realizzati con grande sensibilità nonché competenza e danno un tocco di stile alla vostra cucina, rendendola unica nel suo genere e ricca di carattere.



## Rück- und Seitenwände Pannelli posteriori e laterali

Edelstahlwände setzen starke visuelle Akzente und bieten klare funktionale Vorteile. Rück- und Seitenwände schützen die umliegenden Flächen vor Spritzern und lassen sich besonders leicht reinigen. Eine hochwertige Lösung für Küchen mit Anspruch an Design und Alltagstauglichkeit.

I pannelli in acciaio inox creano un forte impatto visivo e offrono chiari vantaggi funzionali. I pannelli posteriori e laterali proteggono le superfici circostanti dagli schizzi e sono particolarmente facili da pulire. Una soluzione di elevata qualità per cucine che richiedono design e praticità nell'uso quotidiano.

## Verbindung Crea Giunzione Crea

Die Verbindung Crea wird hier primär als gestalterisches Motiv eingesetzt. Das charakteristische Profil dient der visuellen Betonung des Übergangs zwischen gleichen oder unterschiedlichen Materialien wie Edelstahl und Holz, Keramik oder Stein. Dadurch entstehen edle Akzente und ästhetische Kombinationen zwischen kalt und warm, technisch und natürlich, glatt und strukturiert.

La giunzione Crea viene qui utilizzato principalmente come motivo creativo. Il profilo caratteristico serve a sottolineare visivamente il passaggio tra materiali simili o diversi come acciaio inox e legno, ceramica o pietra. Questo crea accenti raffinati e combinazioni estetiche tra freddo e caldo, tecnico e naturale, liscio e strutturato.

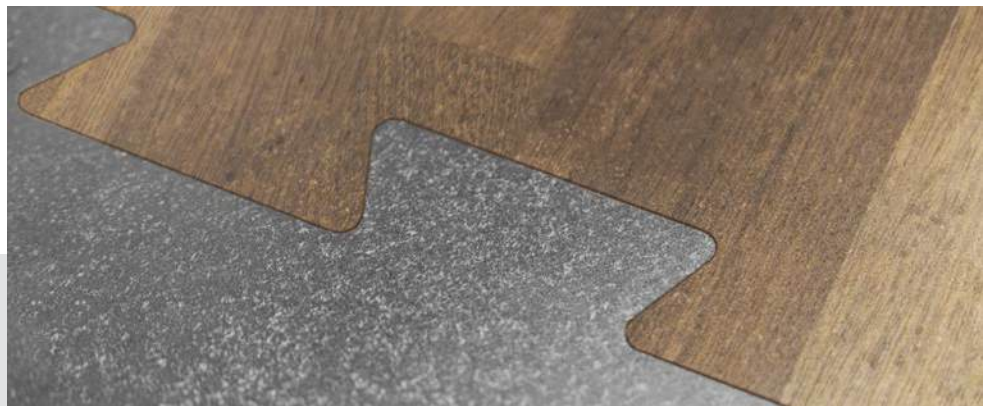

## Solid Art Solid Art

Mit SolidArt sind Ihren ästhetischen und funktionalen Ansprüchen keine Grenzen gesetzt. Die Kombination mit anderen Materialien sorgt für interessante Kontraste. Die SolidArt-Dimensionen sind frei wählbar genauso wie die Form des Moduls.

Con SolidArt nessun limite viene posto alle vostre esigenze di estetica e funzionalità, mentre la combinabilità con altri materiali è portatrice di interessanti contrasti. Si è liberi di scegliere dimensioni e forma del modulo SolidArt, ma anche tra sei finiture superficiali diverse.

## Standardoberflächen / Superfici standard

Edelstahl hat viele Gesichter. Der Oberflächenfinish bestimmt zusammen mit der Schliiff- und Bürstrichtung den optischen Gesamteindruck des edlen Materials. Zur Wahl stehen 4 Standardoberflächen: Seidenmatt-Finish, Wirbel-Finish, Breitband-Finish oder Breitband Varix. Jede Oberfläche inszeniert die wertvolle Struktur des Werkstoffes anders und entlockt ihm dadurch unterschiedliche Spiegelungseigenschaften.

L'acciaio inox è un materiale pregiato che può assumere una grande varietà di apparenze, con un effetto estetico generale che è determinato dalla sua finitura superficiale e dal senso di lucidatura e di spazzolatura. Le superfici standard sono disponibili in 4 finiture: satinata, a turbino, a nastro largo o nastro largo Varix. Ognuna di esse pone diversamente in risalto la pregevole struttura del materiale, traendone una diversità di riflessi.



### Seidenmatt-Finish

Die in Handarbeit gebürstete Oberfläche überzeugt mit einem edlen Glanz, der dem Material eine besondere Tiefe verleiht. Durch die hohe Reflexionskraft werden Licht und Farben der Umgebung wiedergegeben, wodurch sich Seidenmatt-Finish harmonisch in jede Umgebung einfügt.

#### Finitura satinata

La superficie spazzolata a mano si distingue per la sua lucentezza elegante, che conferisce al materiale una profondità particolare. Grazie all'elevato potere riflettente, la luce e i colori dell'ambiente circostante vengono riprodotti, consentendo alla finitura satinata d'integrarsi armoniosamente in qualsiasi ambiente.



### Breitband-Finish

Diese Oberfläche zeichnet sich durch ihre mattierte Optik und den sanften Spiegeleffekt aus. Die charakteristisch geradlinige und besonders regelmässige Struktur entsteht durch den Schliiff mit einem Breiten Band und macht das Finish zu einem zeitlosen Klassiker.

#### Finitura a nastro largo

Questa superficie si contraddistingue per il suo aspetto opaco e il delicato effetto a specchio. La struttura lineare e particolarmente regolare è ottenuta grazie alla levigatura con un nastro largo e rende questa finitura un classico senza tempo.



### Breitband Varix

Diese Oberfläche zeichnet sich durch ihre mattierte Optik und den sanften Spiegeleffekt aus. Die charakteristisch geradlinige und besonders regelmässige Struktur entsteht durch den Schliiff mit einem Breiten Band und macht das Finish zu einem zeitlosen Klassiker.

#### Varix a nastro largo

Questa superficie si contraddistingue per il suo aspetto opaco e il delicato effetto a specchio. La struttura lineare e particolarmente regolare è ottenuta grazie alla levigatura con un nastro largo e rende questa finitura un classico senza tempo.



### Wirbel-Finish

Wirbel-Finish ist eine in Handarbeit erzeugte Oberfläche, die sich durch ihre besonders gleichmässige und sanfte Optik auszeichnet. Der Wirbelschleifer verleiht dem Edelstahl einen abgematteten Look der charakteristisch für dieses dezente Finish ist. Erhältlich mit sTec.

#### Finitura a turbino

La finitura a turbino è realizzata a mano e si contraddistingue per il suo aspetto particolarmente uniforme e delicato. La levigatrice a vortice conferisce all'acciaio inox l'aspetto opaco caratteristico di questa finitura discreta. Disponibile con sTec.



**sTec** ist eine hochwertige Easy-to-Clean- und Antifingerprint-Beschichtung für Edelstahl-Oberflächen. Dabei wird eine farblose und transparente Beschichtung auf den Edelstahl aufgetragen. Die Beschichtung ist UV-beständig, lebensmittelecht sowie visuell und haptisch unauffällig. Sie wirkt wasser- und schmutzabweisend und sorgt so für ein hervorragendes Reinigungsverhalten. Flüssigkeiten perlen ab und Fingerabdrücke haben keine Chance.

**sTec** è un rivestimento molto pregiato Easy-to-Clean e Antifingerprint per superfici in acciaio inox che comporta l'applicazione superficiale di una patina incolore e trasparente. Questo rivestimento è resistente all'ultravioletto, idoneo all'uso alimentare e quasi impercettibile all'occhio e al tatto. Svolge un'azione idrorepellente e antisporno, assicurando quindi un'eccezionale facilità di pulizia. Inoltre, è a prova di liquidi e di impronte digitali.

## Decor Oberflächen / Superfici decor

Mit unseren strukturgewalzten Decor Oberflächen zeigen Sie Persönlichkeit und geben Ihrer Küche ein ganz neues Gesicht. Erhältlich in unterschiedlichen Strukturvarianten, begeistern die Arbeitsplatten mit ihrer edlen Optik, die hervorragend in modern eingerichtete Küchenkonzepte passt.

Le nostre superfici Decor lavorate con rullo strutturato conferiscono alla vostra cucina un carattere a se stante. Disponibili in diverse varianti strutturali, esse affascinano per la loro pregevole estetica che si armonizza magnificamente con i moderni progetti di cucina.

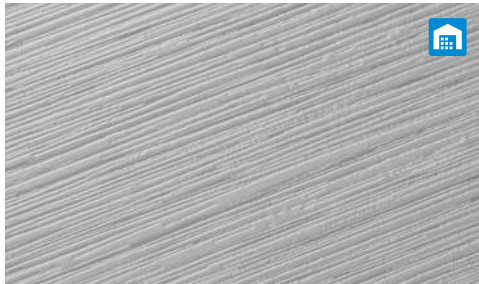

### Polaris Silver

Die markante Struktur von Polaris Silver setzt mit ihrem Look neue Gestaltungsimpulse. Das Finish ist besonders unempfindlich gegenüber Fingerabdrücken und überzeugt durch Designästhetik, Abriebfestigkeit sowie pflegeleichte Funktionalität.

### Polaris Silver

Grazie al suo look, la caratteristica struttura di Polaris Silver fornisce nuovi impulsi al design. La finitura è particolarmente resistente alle impronte digitali e si distingue per l'estetica del design, la resistenza all'abrasione e la sua funzionalità che ne facilita la pulizia.

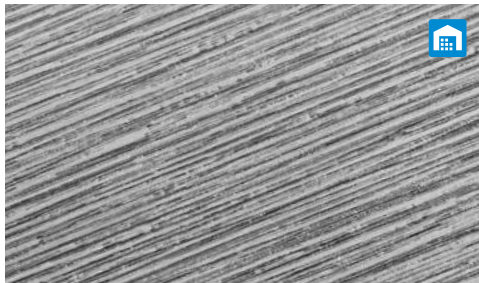

### Polaris Black

Die dunkle Farbgebung verleiht der markanten Struktur von Polaris Black noch mehr Ausdruck. Das Finish ist besonders unempfindlich gegenüber Fingerabdrücken und überzeugt durch Designästhetik, Abriebfestigkeit sowie pflegeleichte Funktionalität.

### Polaris Black

La tonalità scura conferisce ancora più espressività alla caratteristica struttura di Polaris Black. La finitura è particolarmente resistente alle impronte digitali e si distingue per l'estetica del design, la resistenza all'abrasione e la sua funzionalità che ne facilita la pulizia.



### Terra

Diese Oberfläche erzielt durch ihre feinkörnige Struktur eine besonders gleichmäßige, matte Optik. Terra ist vielseitig kombinierbar und fügt sich harmonisch in unterschiedlichste Küchenumgebungen ein. Sie überzeugt zudem durch Abriebfestigkeit und pflegeleichte Funktionalität.

### Terra

Grazie alla sua struttura a grana fine, questa superficie ottiene un effetto opaco particolarmente uniforme. Terra è versatile e s'integra armoniosamente nei più svariati ambienti cucina. Si distingue inoltre per la sua resistenza all'abrasione e la sua funzionalità che ne facilita la pulizia.

## Spezialoberflächen / Superfici speciali

Hochwertig und einzigartig in ihrer Erscheinung. Für höchste Ansprüche an Design und Verarbeitung von Edelstahl bieten unsere Spezialoberflächen mit ausgewählten Strukturen und Materialstärken ein ganz besonderes Highlight für Ihre Küche.

Espressioni di gran pregio e di unicità, le nostre superfici speciali offrono strutture e spessori di materiale selezionati che ben si conciliano con i rigorosi requisiti stilistici e di lavorazione dell'acciaio inox, concepiti per creare distinzione nella vostra cucina.

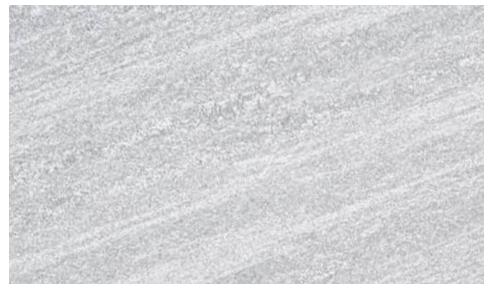

### IceDesign

Diese Premiumoberfläche erfüllt höchste Ansprüche an Design und Robustheit. Das Warmwalzen des Edelstahls schafft eine einzigartige Struktur, die bei jedem Stück individuell ausfällt. Die Hartverchromung verleiht Ice Design nicht nur aussergewöhnliche Widerstandsfähigkeit, sondern auch einen unverwechselbaren Glanz.

### IceDesign

Questa superficie di alta gamma soddisfa le più elevate esigenze in termini di design e robustezza. La laminazione a caldo dell'acciaio inox crea una struttura unica, che risulta diversa in ogni singolo pezzo. La cromatura dura non solo conferisce una resistenza eccezionale a Ice Design, ma anche una lucentezza inconfondibile.



### BlackRange Industrial

Der markante Industrie-Look von BlackRange Industrial setzt mit seiner einzigartigen Struktur ein ausdrucksstarkes Statement. Durch das manuelle Abschleifen der schwarzen Schicht entsteht ein spannendes Spiel aus Schwarz- und Silberanteilen. Das Finish ist ausserdem besonders unempfindlich gegenüber Fingerabdrücken. Gewollte Farb- und Strukturabweichungen prägen den Charakter von BlackRange Industrial.

### BlackRange Industrial

Il caratteristico look industriale di BlackRange Industrial è di grande intensità espressiva per quanto riguarda la sua struttura unica. La levigatura manuale dello strato nero crea un emozionante gioco di parti nere e argentate. La finitura è inoltre particolarmente resistente alle impronte digitali. Le variazioni cromatiche e strutturali volute contraddistinguono il carattere di BlackRange Industrial.



### BlackRange Passion

Die tiefdunkle Optik von BlackRange Passion verleiht der Oberfläche eine elegante, anmutige Ausstrahlung. Ihre individuelle Struktur erzeugt ein sanftes Farbspiel, das das ausdrucksstarke Erscheinungsbild auf dezente Weise unterstreicht. Das Finish ist ausserdem besonders unempfindlich gegenüber Fingerabdrücken. Gewollte Farb- und Strukturabweichungen prägen den Charakter von BlackRange Passion.

### BlackRange Passion

L'aspetto scuro e profondo di BlackRange Passion conferisce un aspetto elegante e raffinato alla superficie. La sua struttura unica crea un delicato gioco di colori che ne sottolinea in modo discreto l'aspetto espressivo. La finitura è inoltre particolarmente resistente alle impronte digitali. Le variazioni cromatiche e strutturali volute contraddistinguono il carattere di BlackRange Passion.



### Individuelle Bemusterung für IceDesign und BlackRange

Unsere Premiumoberflächen IceDesign und BlackRange sind in jeder Hinsicht echte Unikate. Aufgrund dieser Einzigartigkeit bieten wir die Möglichkeit, diese Oberflächen persönlich vor der Verarbeitung in unserer Edelstahl-Manufaktur auszusuchen. Kontakt für Terminvereinbarung: T + 41 58 263 64 00, [bemusterung@suter.ch](mailto:bemusterung@suter.ch)

### Campionatura individuale per IceDesign e BlackRange

Le nostre superfici di alta gamma IceDesign e BlackRange sono dei pezzi unici sotto ogni aspetto. Data la loro unicità, offriamo la possibilità di scegliere queste superfici di persona prima della lavorazione presso la nostra manifattura di acciaio inox. Contattateci per fissare un appuntamento. T + 41 58 263 64 00, [bemusterung@suter.ch](mailto:bemusterung@suter.ch)

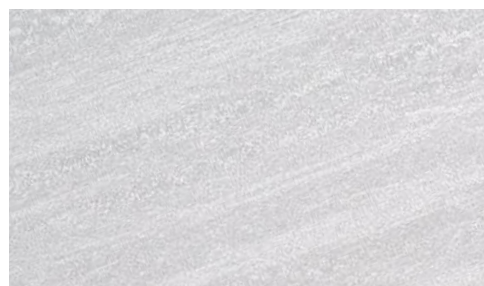

### Polar Look

Diese Oberfläche verbindet eine extravagante Optik mit einer markanten, zugleich dezent wirkenden Struktur. Der warmgewalzte Edelstahl erhält durch die Veredelung mittels Elektropolitur einen seidigen Schimmer, der das Licht sanft reflektiert und Polar Look eine faszinierende Tiefenwirkung verleiht. Das Ergebnis ist ein Finish, das modern und edel zugleich ist.

### Polar Look

Questa superficie coniuga un look stravagante a una struttura distintiva ma allo stesso tempo discreta. L'acciaio inox laminato a caldo ottiene una lucentezza satinata grazie alla finitura mediante pulitura elettrolitica, che riflette delicatamente la luce conferendo a Polar Look un affascinante effetto di profondità. Il risultato è una finitura moderna e raffinata allo stesso tempo.

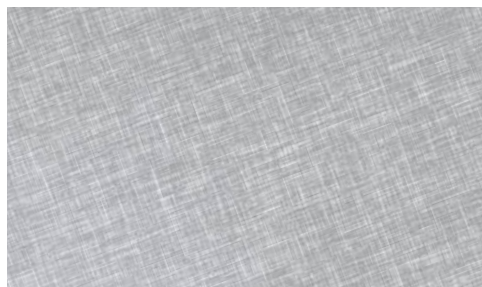

### Xrange Ice

Die im Kreuz geschliffene Struktur von Xrange Ice ist optisch und haptisch einzigartig und verleiht dem Edelstahl ein neues Gesicht. Die Hartverchromung sorgt nicht nur für aussergewöhnliche Widerstandsfähigkeit, sondern auch für einen unverwechselbaren Glanz und eine kühle Farbgebung, die die markante Struktur von Xrange Ice hervorhebt.

#### Xrange Ice

La struttura rettificata a croce di Xrange Ice è unica all'occhio e al tatto e conferisce all'acciaio inox un nuovo volto. La cromatura dura non solo garantisce una resistenza eccezionale, ma anche una lucentezza inconfondibile e una colorazione fresca che mette in risalto la struttura distintiva di Xrange Ice.

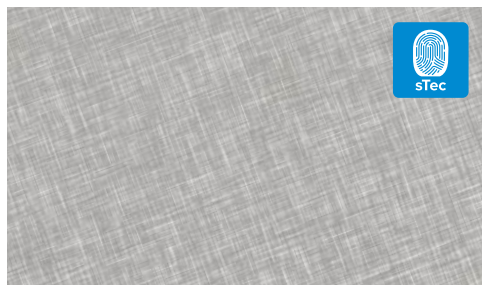

### Xrange Finline

Die im Kreuz geschliffene Struktur von Xrange Finline ist optisch und haptisch einzigartig und verleiht dem Edelstahl ein neues Gesicht. Das matte Finish in warmer Farbgebung offenbart je nach Lichteinfall dezente Glanznuancen und fügt sich harmonisch in das Küchenkonzept ein. Erhältlich mit sTec.

#### Xrange Finline

La struttura rettificata a croce di Xrange Finline è unica sia all'occhio che al tatto e conferisce un nuovo volto all'acciaio inox. La finitura opaca dai colori caldi rivela sottili sfumature lucide a seconda dell'incidenza della luce e s'integra armoniosamente nel progetto di cucina. Disponibile con sTec.

Auch in der SmartSteel Collection verfügbar / Disponibile anche nella SmartSteel Collection

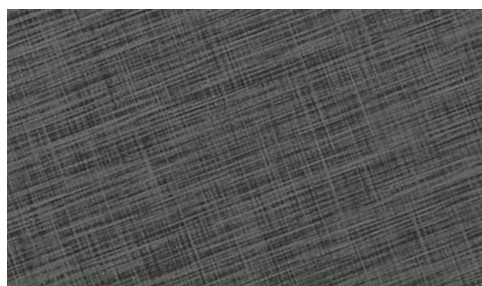

### Xrange Black

Die im Kreuz geschliffene Struktur von Xrange Black enthüllt eine wirkungsvolle Schwarz-Silber-Optik und bringen den Charakter des Edelstahls in besonderer Weise zum Ausdruck. Die variablen Schwarznuancen werden durch Lichteinfall und Perspektive zum Vorschein gebracht und prägen die Ausstrahlung von Xrange Black.

#### Xrange Black

La struttura rettificata a croce di Xrange Black rivela un suggestivo effetto nero-argento ed esalta in modo particolare il carattere dell'acciaio inox. Le tonalità variabili del nero vengono messe in risalto dall'incidenza della luce come pure dalla prospettiva e caratterizzano l'aspetto di Xrange Black.



### Silk Look

Diese Oberfläche überzeugt durch eine matte Optik und lebendige Struktur. Der warmgewalzte Edelstahl wird von Hand mit einem Wirbelschleifer bearbeitet, wodurch ein feines, lebendiges Finish entsteht. Dabei bleibt der charakteristische Charme der Warmwalzung bei Silk Look dezent erhalten. Erhältlich mit sTec.

#### Silk Look

Questa superficie si distingue grazie al suo aspetto opaco e alla sua struttura vivace. L'acciaio inox laminato a caldo viene lavorato a mano con una levigatrice a vortice, ottenendo così una finitura fine e vivace. Il fascino caratteristico della laminazione a caldo viene mantenuto in modo discreto per quanto riguarda Silk Look. Disponibile con sTec.

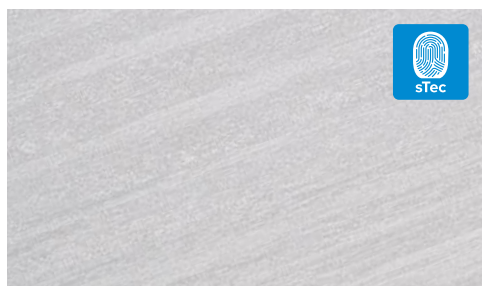

### Warmgewalzt \*

Eine besonders matte und unregelmässige Struktur prägt den Charakter dieser warmgewalzten Oberfläche. Sie entsteht direkt während des Walzvorgangs und ist daher bei jeder Platte einzigartig. Ein Unikat, das sowohl optisch als auch haptisch exklusiv ist. Erhältlich mit sTec.

#### Laminazione a caldo \*

Una struttura particolarmente opaca e irregolare caratterizza questa superficie laminata a caldo e si forma direttamente durante il processo di laminazione ed è quindi unica per ogni lastra. Un pezzo unico, esclusivo sia all'occhio che al tatto. Disponibile con sTec.

\* **Warmgewalzter Edelstahl:** Kleine Unregelmässigkeiten, Farb- und Strukturunterschiede sind rohmaterialbedingt und Teil der Einzigartigkeit der Massanfertigungen.

\* **Acciaio inox laminato a caldo:** Piccole irregolarità, differenze cromatiche e strutturali sono dovute alle caratteristiche della materia prima e sono parte dell'unicità delle realizzazioni su misura.



**sTec** ist eine hochwertige Easy-to-Clean- und Antifingerprint-Beschichtung für Edelstahl-Oberflächen. Dabei wird eine farblose und transparente Beschichtung auf den Edelstahl aufgetragen. Die Beschichtung ist UV-beständig, lebensmittelecht sowie visuell und haptisch unauffällig. Sie wirkt wasser- und schmutzabweisend und sorgt so für ein hervorragendes Reinigungsverhalten. Flüssigkeiten perlen ab und Fingerabdrücke haben keine Chance.

**sTec** è un rivestimento molto pregiato Easy-to-Clean e Antifingerprint per superfici in acciaio inox che comporta l'applicazione superficiale di una patina incolore e trasparente. Questo rivestimento è resistente all'ultravioletto, idoneo all'uso alimentare e quasi impercettibile all'occhio e al tatto. Svolge un'azione idrorepellente e antisporco, assicurando quindi un'eccezionale facilità di pulizia. Inoltre, è a prova di liquidi e di impronte digitali.

## Oberflächen im Vergleich / Superfici a confronto

## Standardoberflächen / Superfici standard

Oberflächen Superfici		GREEN LINE	sTec	Erhältliche Kantenhöhen (in mm) Altezze di bordi disponibili (in mm)		Max. Abmessungen <sup>1</sup> (in mm) Dimensioni max. <sup>1</sup> (in mm)		L- oder U-Winkel Angolo a «L» o a «U»	
				SmartSteel Collection	SolidSteel Collection	SmartSteel Collection	SolidSteel Collection	Einteilig <sup>2</sup> Intera <sup>2</sup>	Mehrteilig <sup>3</sup> In più parti <sup>3</sup>
Seidenmatt-Finish Finitura satinata	SF	✓	–	A12 - A100 A20 + A30	–	6000 × 1750 3900 × 1400	–	✓	✓
Breitband-Finish Finitura a nastro largo	BF	✓	–	A12 - A100 A20 + A30	–	6000 × 1750 3900 × 1400	–	✓	✓
		–	–	–	M15 - 300 M4/M5/M8	–	3980 × 1980 × 4 4980 × 1980 × 5/8	–	✓
Breitband Varix Nastro largo Varix	BX	–	–	A20, A30, A40	–	3900 × 1400	–	–	✓
Wirbel-Finish Finitura a turbino	WF	✓	–	A12 - A100 A20 + A30	–	6000 × 1750 3900 × 1400	–	✓	✓
		–	–	–	M15 - 300 M4/M8	–	3980 × 1980 × 4 4980 × 1980 × 8	–	✓
		–	✓	–	M15 - 300 M4/M8	–	3980 × 1480	–	✓

## Decor Oberflächen / Superfici Decor

Oberflächen Superfici		GREEN LINE	sTec	Erhältliche Kantenhöhen (in mm) Altezze di bordi disponibili (in mm)		Max. Abmessungen <sup>1</sup> (in mm) Dimensioni max. <sup>1</sup> (in mm)		L- oder U-Winkel Angolo a «L» o a «U»	
				SmartSteel Collection	SolidSteel Collection	SmartSteel Collection	SolidSteel Collection	Einteilig <sup>2</sup> Intera <sup>2</sup>	Mehrteilig <sup>3</sup> In più parti <sup>3</sup>
Polaris Silver	PS	–	–	A12 - A40	–	3900 × 1400	–	–	✓
Polaris Black	PB	–	–	A12 - A40	–	3900 × 1400	–	–	✓
Terra	TR	–	–	A12 - A40	–	3900 × 1400	–	–	✓

## Spezialoberflächen / Superfici speciali

Oberflächen Superfici		GREEN LINE	sTec	Erhältliche Kantenhöhen (in mm) Altezze di bordi disponibili (in mm)		Max. Abmessungen <sup>1</sup> (in mm) Dimensioni max. <sup>1</sup> (in mm)		L- oder U-Winkel Angolo a «L» o a «U»	
				SmartSteel Collection	SolidSteel Collection	SmartSteel Collection	SolidSteel Collection	Einteilig <sup>2</sup> Intera <sup>2</sup>	Mehrteilig <sup>3</sup> In più parti <sup>3</sup>
IceDesign	ID	–	–	–	M15 - 300 M4/M8	–	3950 × 1450 × 4 4950 × 1450 × 8	–	✓
BlackRange Industrial	BI	–	–	–	M15 - 300 M8	–	3900 × 1400	–	✓
BlackRange Passion	BP	–	–	–	M15 - 300 M8	–	3900 × 1400	–	✓
Polar Look	PL	–	–	–	M15 - 300 M4/M8	–	3950 × 1450 × 4 4950 × 1450 × 8	–	✓
Xrange Ice	XI	–	–	–	M15 - 300 M4	–	3900 × 1450	–	✓
Xrange Finline	XF	–	✓	–	M15 - 300 M4	–	3900 × 1480	–	✓
		–	✓	A12 - A40	–	3900 × 1400	–	–	✓
Xrange Black	XB	–	–	–	M15 - 300 M4	–	3900 × 1480	–	✓
Silk Look	SL	–	✓	–	M15 - 300 M4/M8	–	3950 × 1450 × 4 4950 × 1450 × 8	–	✓
Warmgewalzt Laminazione a caldo	WG	–	✓	–	M15 - 300 M4/M8	–	3950 × 1450 × 4 4950 × 1450 × 8	–	✓

sTec ist eine hochwertige Easy-to-Clean- und Antifingerprint-Beschichtung.  
Mehr Informationen auf Seite 20.

sTec è un rivestimento molto pregiato Easy-to-Clean e Antifingerprint.  
Più informazioni sulla pag. 20.

**Green Line** ist eine eigenständige auf Nachhaltigkeit ausgerichtete Produktausführung.  
Mehr Informationen auf Seite 6.

**Green Line** è una versione di prodotto autonoma calibrata sulla sostenibilità.  
Più informazioni sulla pag. 6.

<sup>1</sup> Übergrößen auf Anfrage / Dimensioni speciali su richiesta

<sup>2</sup> Einteilig/Intera: - Mit Schweissnaht/Con giunto saldato

<sup>3</sup> Mehrteilig/In più parti: - Standard- und Decor Oberflächen mit Stecknaht/  
Superfici standard e Decor con giunto ad innesto sovrapposto  
- Spezialoberflächen mit Stoss- oder Steckverbindung/  
Superfici speciali con giunto di testa o ad innesto sovrapposto

## Serviceleistungen Edelstahl-Massanfertigungen

### Servizi soluzioni a misura in acciaio inox



#### Ausmess-Service

##### Servizio di misurazione

Sparen Sie Zeit und reduzieren Sie das Fehlerrisiko, indem Sie von unserem professionellen Ausmess-Service profitieren. Erfahrene Fachkräfte prüfen bauliche Voraussetzungen und erstellen exakte Skizzen für die Fertigung<sup>1</sup>.

Usufruendo del nostro servizio professionale di misurazione, riducete il rischio di errori e risparmiate tempo prezioso. I nostri tecnici specializzati provvedono ad accertare i requisiti strutturali e ad eseguire precisi schizzi preliminari per la fabbricazione<sup>1</sup>.



#### Kundendienst / Servizio clienti

T +41 58 263 64 80  
kundendienst@suter.ch  
servizioclienti@suter.ch  
suter.ch/service

#### Montage-Service

##### Servizio di montaggio

Wir bringen die bestellte Edelstahl-Massanfertigung termingerecht auf die Baustelle und montieren sie professionell vor Ort. So kommen alle Arbeiten rund um den Edelstahl aus einer Hand und Sie profitieren von einem reibungslosen Ablauf<sup>1</sup>.

Noi consegniamo con puntualità la soluzione su misura in acciaio inox da voi ordinata e provvediamo al suo montaggio direttamente sul posto con la massima professionalità. Tutto ciò che riguarda la messa in opera dell'acciaio inox viene così preso in carico da un unico interlocutore e portato a termine senza il minimo inconveniente<sup>1</sup>.

#### Auffrisch- und Pflegeservice

##### Servizio di pulizia e manutenzione

Edelstahl lebt – genau wie Ihre Küche. Jede Berührung, jeder Moment hinterlässt Spuren, die zeigen, dass hier gekocht, gelacht und gelebt wird. Diese natürliche Patina ist kein Makel, sondern Teil der ganz besonderen Ausstrahlung Ihres Zuhauses. Mit unserem neuen Auffrisch- und Pflegeservice bewahren wir genau diese Lebendigkeit und bringen Ihren Edelstahl gleichzeitig wieder in seine schönste Form<sup>1</sup>.

L'acciaio inox è vivo, proprio come la vostra cucina. Ogni tocco, ogni momento lascia tracce che dimostrano che qui si cucina, si ride e si vive. Questa patina naturale non è un difetto, ma parte integrante del fascino unico della vostra casa. Con il nostro nuovo servizio di pulizia e manutenzione preserviamo proprio questa vivacità, riportando il vostro acciaio inox alla sua forma più bella<sup>1</sup>.

#### Direktlieferung auf die Baustelle

##### Consegna diretta a piè d'opera

Gerade bei Abdeckungen mit Übergrößen oder Sondermassen ist ein termin- und fachgerechter Transport wichtig. Deshalb bieten wir Ihnen auf Wunsch eine direkte Lieferung auf die Baustelle an. Nebst dem Liefertermin können Sie ebenfalls ein Zeitfenster von zwei Stunden wählen<sup>1</sup>.

Soprattutto nel caso di coperture sovradimensionate o con misure speciali, è importante poter contare su puntualità e adeguatezza del trasporto. Su richiesta, saremo quindi lieti di offrirvi la consegna diretta a piè d'opera. Oltre al termine di consegna, è possibile selezionare una finestra temporale di due ore<sup>1</sup>.

#### Kontakt für Terminvereinbarung / Contatto per fissare un termine di consegna

Gerne liefern wir Ihnen Ihre Abdeckung von Montag bis Freitag. In einzelnen Gebieten und Randregionen sind Lieferungen erst ab 10:00 Uhr möglich. Gerne informieren wir Sie direkt bei der Terminvereinbarung über unsere Möglichkeiten.

Saremo lieti di consegnare la vostra copertura da lunedì a venerdì. In alcune zone e regioni periferiche le consegne sono possibili solo a partire dalle ore 10:00. Saremo lieti d'informarvi direttamente sulla nostra possibile disponibilità al momento di fissare il termine di consegna.

T +41 58 263 64 00  
suter@suter.ch

#### Individuelle Bemusterung

##### für IceDesign und BlackRange

##### Campionatura individuale

##### per IceDesign e BlackRange

Unsere Premiumoberflächen IceDesign und BlackRange sind in jeder Hinsicht echte Unikate. Aufgrund dieser Einzigartigkeit bieten wir die Möglichkeit, diese Oberflächen persönlich vor der Verarbeitung in unserer Edelstahl-Manufaktur auszusuchen.

Le nostre superfici di alta gamma IceDesign e BlackRange sono dei pezzi unici sotto ogni aspetto. Data la loro unicità, offriamo la possibilità di scegliere queste superfici di persona prima della lavorazione presso la nostra manifattura di acciaio inox.

#### Zentrale / Centralino

T +41 58 263 64 00  
bemusterung@suter.ch

<sup>1</sup>Preis auf Anfrage. / Prezzo su richiesta.

## Massanfertigungs-Formen / Forme delle soluzioni su misura



## Einzeilig / Su una linea

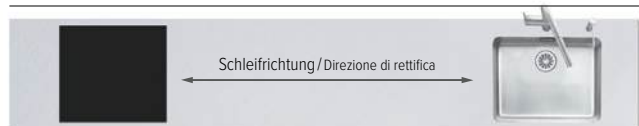

## Erhältliche Ausführung / Lavorazione disponibile

SmartSteel Collection



SolidSteel Collection



## Erhältliche Oberflächen / Superfici disponibili

Standard

SF

BF

BX

WF

Decor

PS

PB

TR

Spezial

ID

BI

BP

PL

XI

XF

XB

SL

WG

Weitere Produktinformationen / Altre informazioni prodotto

## Zweizeilig / Su due linee



## Erhältliche Ausführung / Lavorazione disponibile

SmartSteel Collection



SolidSteel Collection



## Erhältliche Oberflächen / Superfici disponibili

Standard

SF

BF

BX

WF

Decor

PS

PB

TR

Spezial

ID

BI

BP

PL

XI

XF

XB

SL

WG

Weitere Produktinformationen / Altre informazioni prodotto

**L-Winkel / A «L»**



**Erhältliche Ausführung / Lavorazione disponibile**

SmartSteel Collection   SolidSteel Collection

**Erhältliche Oberflächen / Superfici disponibili**

Standard SF BF BX WF  
 Decor  PS PB TR  
 Spezial ID BI BP PL XI XF XB SL WG

Weitere Produktinformationen / Altre informazioni prodotto  20-23

**U-Winkel / A «U»**



**Erhältliche Ausführung / Lavorazione disponibile**

SmartSteel Collection   SolidSteel Collection

**Erhältliche Oberflächen / Superfici disponibili**

Standard SF BF BX WF  
 Decor  PS PB TR  
 Spezial ID BI BP PL XI XF XB SL WG

Weitere Produktinformationen / Altre informazioni prodotto  20-23

**Kochinsel / Isola di cottura**



**Erhältliche Ausführung / Lavorazione disponibile**

SmartSteel Collection   SolidSteel Collection

**Erhältliche Oberflächen / Superfici disponibili**

Standard SF BF BX WF  
 Decor  PS PB TR  
 Spezial ID BI BP PL XI XF XB SL WG

Weitere Produktinformationen / Altre informazioni prodotto  20-23

## Massanfertigungs-Formen / Forme delle soluzioni su misura

### Kochinsel mit Rundung / Isola di cottura con arrotondamento



#### Erhältliche Ausführung / Lavorazione disponibile

SmartSteel Collection



SolidSteel Collection



#### Erhältliche Oberflächen / Superfici disponibili

Standard

SF

BF

WF

Spezial

ID

BI

BP

PL

XI

XB

SL

WG

Weitere Produktinformationen / Altre informazioni prodotto



### L-Winkel mit Eckschräge 45° einfach / A «L» con taglio inclinato a 45° semplice

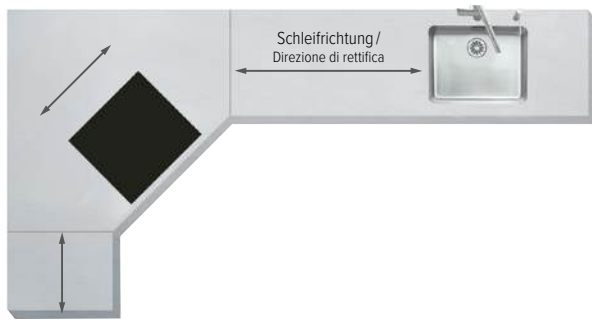

#### Erhältliche Ausführung / Lavorazione disponibile

SmartSteel Collection



SolidSteel Collection



#### Erhältliche Oberflächen / Superfici disponibili

Standard

SF

BF

BX

WF

Decor



PS

PB

TR

Spezial

ID

BI

BP

PL

XI

XF

XB

SL

WG

Weitere Produktinformationen / Altre informazioni prodotto



### L-Winkel mit Eckschräge 45° doppelt / A «L» con taglio inclinato a 45° doppio



#### Erhältliche Ausführung / Lavorazione disponibile

SmartSteel Collection



SolidSteel Collection



#### Erhältliche Oberflächen / Superfici disponibili

Standard

SF

BF

BX

WF

Decor



PS

PB

TR

Spezial

ID

BI

BP

PL

XI

XF

XB

SL

WG

Weitere Produktinformationen / Altre informazioni prodotto



**Offener U-Winkel / A «U» aperta**



**Erhältliche Ausführung / Lavorazione disponibile**

SmartSteel Collection

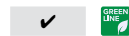

SolidSteel Collection



**Erhältliche Oberflächen / Superfici disponibili**

Standard

SF BF BX WF

Decor

PS PB TR

Spezial

ID BI BP PL XI XF XB SL WG

Weitere Produktinformationen / Altre informazioni prodotto

**Offener L-Winkel mit tiefer gesetzter Arbeitsfläche / A «L» aperta, con piano di lavoro ribassato**

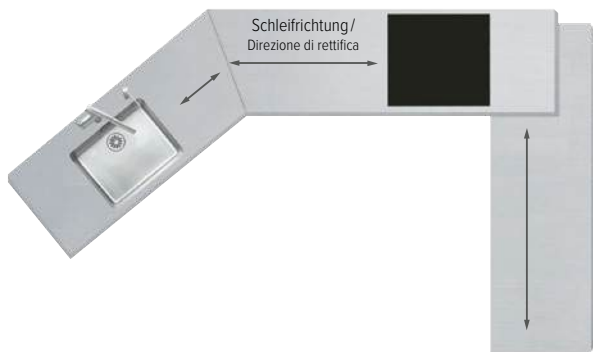

**Erhältliche Ausführung / Lavorazione disponibile**

SmartSteel Collection

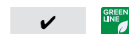

SolidSteel Collection



**Erhältliche Oberflächen / Superfici disponibili**

Standard

SF BF BX WF

Decor

PS PB TR

Spezial

ID BI BP PL XI XF XB SL WG

Weitere Produktinformationen / Altre informazioni prodotto

**Mehrteilig (Schulküche) / Composita (cucina per uso scolastico)**



**Erhältliche Ausführung / Lavorazione disponibile**

SmartSteel Collection



SolidSteel Collection



**Erhältliche Oberflächen / Superfici disponibili**

Standard

SF BF BX WF

Decor

PS PB TR

Spezial

ID BI BP PL XI XF XB SL WG

Weitere Produktinformationen / Altre informazioni prodotto



**Kochinsel einteilig seitwärts an den Boden gezogen / Isola di cottura in pezzo unico**

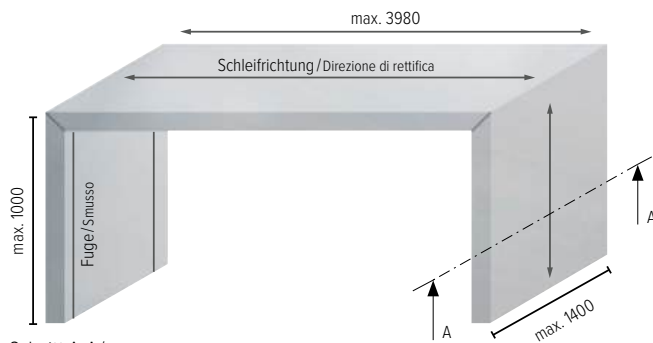

Schnitt A-A / Intaglio A-A

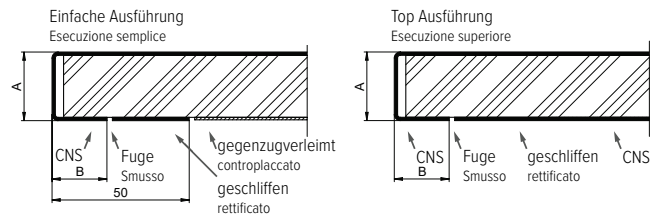

**Erhältliche Ausführung / Lavorazione disponibile**

SmartSteel Collection  SolidSteel Collection

**Erhältliche Oberflächen / Superfici disponibili**

Standard  SF  BF  WF

Weitere Produktinformationen / Altre informazioni prodotto 20

**i** Größere Abmessung und Quetschkante frontbündig auf Anfrage.  
Dimensioni speciali e bordo pressato a filo frontale su richiesta.

Abkantungen SmartSteel Collection mit Standardoberflächen  
Piegature lamiera sottile con SmartSteel Collection

Erhältliche Kantenhöhe in mm (A) Altezza di bordo disponibile in mm (A)	12	15	20-100
Länge Abkantung in mm (B) Lunghezza piegatura in mm (B)	10	20	50

**Kochinsel einteilig seitwärts an den Boden gezogen / Isola di cottura in pezzo unico**

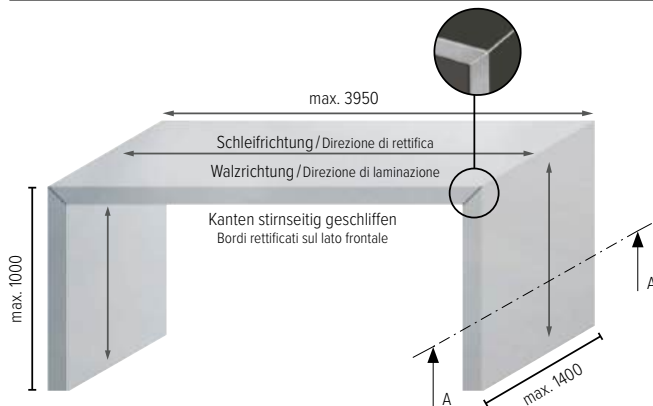

Schnitt A-A / Intaglio A-A

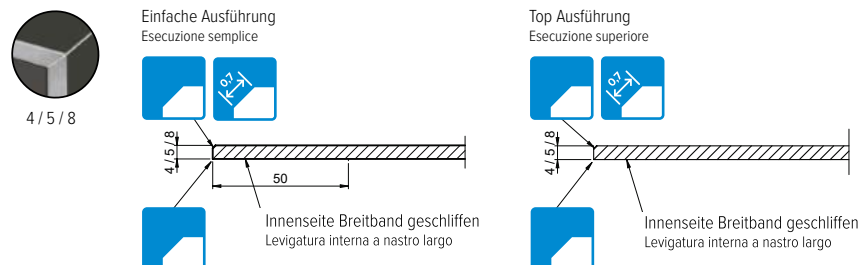

**Erhältliche Ausführung / Lavorazione disponibile**

SmartSteel Collection  SolidSteel Collection

**Erhältliche Oberflächen / Superfici disponibili**

Standard  BF  WF  
Spezial  ID  BI  BP  PL  XI  XF  XB  SL  WG

Weitere Produktinformationen / Altre informazioni prodotto 20+22

**Kochinsel mehrteilig seitwärts an den Boden gezogen / Isola di cottura in più parti**

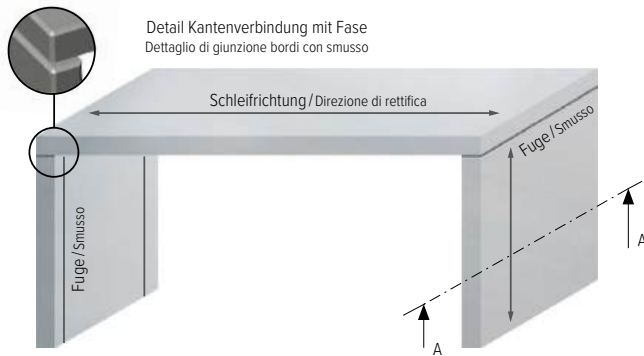

**Erhältliche Ausführung / Lavorazione disponibile**

SmartSteel Collection  SolidSteel Collection

**Erhältliche Oberflächen / Superfici disponibili**

Standard SF BF WF  
 Decor PS PB TR  
 Spezial XF

Weitere Produktinformationen / Altre informazioni prodotto 20-23

SmartSteel Collection mit Standardoberflächen / SmartSteel Collection con superfici standard

Schnitt A-A / Intaglio A-A  
Einfache Ausführung  
Esecuzione semplice

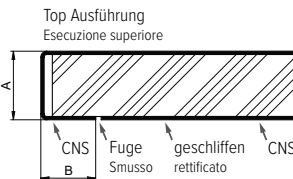
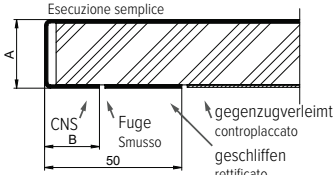

**i** Die Massanfertigung mit Seitenwangen wird aus Einzel-Schenkel gefertigt. Größere Abmessung, Quetschkante frontbündig sowie die Verbindung von Seitenwangen und Abstellfläche in der Gehrung auf Anfrage.

La soluzione su misura con spalle laterali viene realizzata con fianco unico. Dimensioni maggiori, bordo pressato a filo frontale, nonché la giunzione di spalle laterali e superficie d'appoggio nello smusso, sono su richiesta.

SmartSteel Collection mit Decor Oberflächen und XF / SmartSteel Collection con superfici decor e XF

Schnitt A-A / Intaglio A-A  
Einfache Ausführung  
Esecuzione semplice

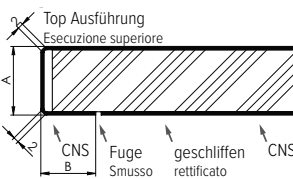
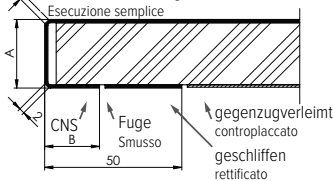

Abkantungen SmartSteel Collection / Piegature SmartSteel Collection

Erhältliche Kantenhöhe in mm (A) Altezza di bordo disponibile in mm (A)	12	15	20-100
Länge Abkantung in mm (B) Lunghezza piegatura in mm (B)	10	20	50

**i** Decor Oberflächen und XF bis Kantenhöhe A40 erhältlich. Superficie Decor e XF disponibile fino all'altezza di bordo A40.

**Kochinsel mehrteilig seitwärts an den Boden gezogen / Isola di cottura in più parti**

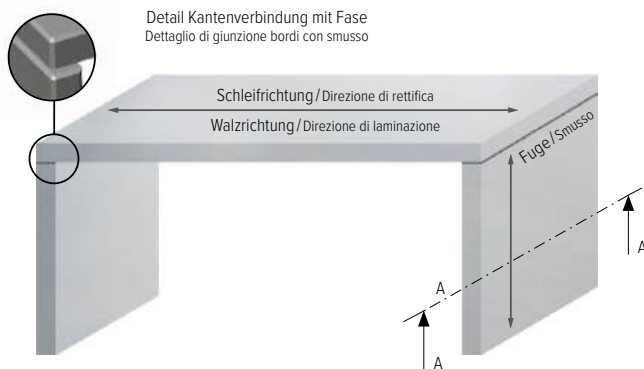

**Erhältliche Ausführung / Lavorazione disponibile**

SmartSteel Collection  SolidSteel Collection

**Erhältliche Oberflächen / Superfici disponibili**

Standard BF WF  
 Spezial ID BI BP PL XI XF XB SL WG

Weitere Produktinformationen / Altre informazioni prodotto 20-22

Schnitt A-A / Intaglio A-A

Einfache Ausführung  
Esecuzione semplice



Top Ausführung  
Esecuzione superiore

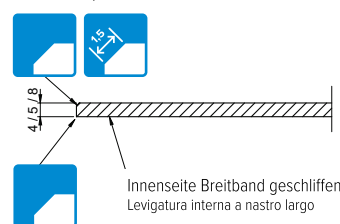

**i** Die Massanfertigung mit Seitenwangen wird aus Einzel-Schenkel gefertigt. Größere Abmessung sowie die Verbindung von Seitenwangen und Abstellfläche in der Gehrung auf Anfrage.

La soluzione su misura con spalle laterali viene realizzata con fianco unico. Dimensioni maggiori, nonché la giunzione di spalle laterali e superficie d'appoggio nello smusso, sono su richiesta.



### Überhängende Arbeitsplatte / Piano di lavoro sporgente

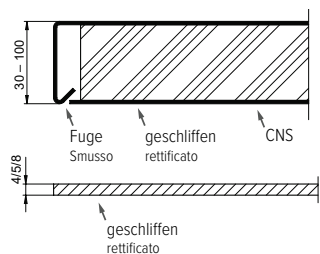
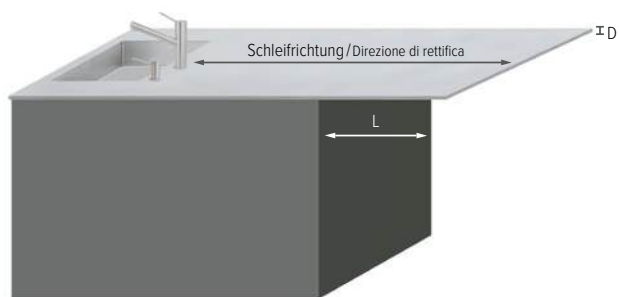

Kantenhöhe (D) / Altezza di bordo (D)		Überhang (L) / Sporgente (L)
SmartSteel Collection	SolidSteel Collection	
A12 – A20	M4 / M5 mm	Auf Anfrage / Su richiesta
A30	M8 mm	300 mm
A40 – A100	–	500 mm

#### Erhältliche Ausführung / Lavorazione disponibile

SmartSteel Collection



SolidSteel Collection



#### Erhältliche Oberflächen / Superfici disponibili

Standard

SF

BF

WF

Decor



PS

PB

TR

Spezial

ID

BI

BP

PL

XI

XF

XB

SL

WG

Weitere Produktinformationen / Altre informazioni prodotto 20-23

#### **i** Montageempfehlung: Trägerplatte verwenden

In Abhängigkeit der Einbausituation ist als zusätzliche Verstärkung ein Vierkant-/Rechteckrohr einzurechnen. Ist der Überhang grösser als die angegebenen Masse wird eine Abstützung empfohlen. Unabhängig von der Ausführung und der Oberfläche wird die sichtbare Unterseite in der Oberfläche Breitband-Finish ausgeführt.

Raccomandazione per il montaggio: utilizzare una piastra di supporto

A seconda della situazione di montaggio, come rinforzo supplementare occorre prevedere l'impiego di un tubo rettangolare/quadro. Se la sporgenza è maggiore della misura indicata, si raccomanda l'uso di un supporto. Indipendentemente dal tipo di esecuzione e dalla superficie, il lato inferiore a vista viene eseguito con finitura superficiale a nastro largo.

### Schleifrichtungen / Direzione di rettifica

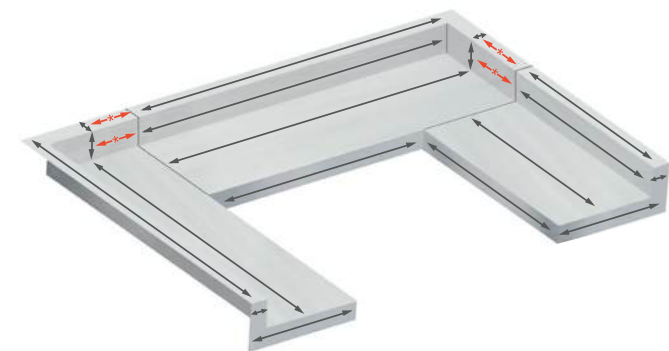

Schleifrichtung Standard ohne Aufpreis  
Direzione di rettifica standard senza maggiorazione



Änderung der Schleifrichtung gegen Aufpreis.  
Modifica della direzione di levigatura contro supplemento.

#### Erhältliche Ausführung / Lavorazione disponibile

SmartSteel Collection



SolidSteel Collection



#### Erhältliche Oberflächen / Superfici disponibili

Standard

SF

BF

**i** Winkelförmige Massanfertigungen können in allen Winkelmassen ausgeführt werden. Bei Übergrößen muss je nach Transport- und Montagemöglichkeit in der Küche (Handling in einem Stück, Gewicht) eventuell eine Stecknaht oder eine Stossverbindung vorgesehen werden.

Nelle soluzioni su misura a sezione curva, le superfici curve e i telai devono essere saldati. Le soluzioni su misura ad angolo possono essere realizzate con angoli di qualsiasi misura. In caso di dimensioni speciali, a seconda delle possibilità di trasporto e di montaggio in cucina (gestione di un unico pezzo, peso) va eventualmente previsto un giunto a innesto sovrapposto, un giunto di testa o un collegamento a innesto.

**Überhängende Arbeitsplatte Varix / Piano di lavoro sporgente Varix**

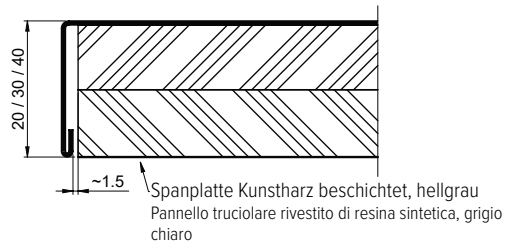
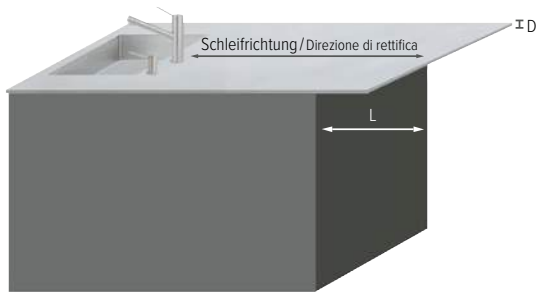

Kantenhöhe (D) / Altezza di bordo (D)	Überhang (L) / Sporgente (L)
SmartSteel Collection	
A20	max. 150 mm
A30	max. 200 mm
A40	max. 200 mm

**Erhältliche Ausführung / Lavorazione disponibile**

SmartSteel Collection

SolidSteel Collection

**Erhältliche Oberflächen / Superfici disponibili**

Standard  SF  BF  BX  WF

Weitere Produktinformationen / Altre informazioni prodotto 

**i** Montageempfehlung: Trägerplatte verwenden  
 In Abhängigkeit der Einbausituation ist als zusätzliche Verstärkung ein Vierkant-/Rechteckrohr einzurechnen. Ist der Überhang grösser als die angegebenen Masse wird eine Abstützung empfohlen.

Suggerimento per il montaggio: utilizzare una piastra di supporto  
 A seconda della situazione d'installazione, è necessario includere un tubo quadrato/rettangolare come rinforzo aggiuntivo. Se la sporgenza è superiore alle dimensioni specificate, si consiglia di utilizzare un supporto.

**Schleifrichtungen Varix / Direzione di rettifica Varix**



 Schleifrichtung Standard  
 Direzione di rettifica standard

**Erhältliche Ausführung / Lavorazione disponibile**

SmartSteel Collection

SolidSteel Collection

**Erhältliche Oberflächen / Superfici disponibili**

Standard  BX

**i** Winkelförmige Massanfertigungen können in allen Winkelmassen ausgeführt werden. In der Kantenausführung nur mit Stecknaht möglich.

Le soluzioni su misura ad angolo possono essere realizzate in tutte le dimensioni angolari. La bordatura possibile solo con un giunto a innesto.



## Kantenausführung und -Design für SmartSteel Collection

### Versioni e design di bordi in SmartSteel Collection



#### Kante geschliffen ohne Fase (Radius) Bordo rettificato senza smusso (raggio)

Erhältlich für Oberfläche  
Disponibile per superficie

Standard  SF  BF  BX  WF



#### Kante geschliffen mit Fase 1.5/45° Bordo rettificato con smusso 1.5/45°

Erhältlich für Oberfläche  
Disponibile per superficie

Standard  SF  BF  BX  WF

Decor   PS  PB  TR

Spezial  XF



 Bei Standardoberflächen wird seitlich der entsprechende Oberflächenschliff angewendet (z.B. Wirbel-Finish).  
Sui lati delle superfici standard viene utilizzata la rispettiva rettifica superficiale (per es. finitura a turbino).

Schleifrichtung Varix s. Seite 33

Senso di levigatura Varix, vedi pagina 33

## Kantenausführung und -Design für SolidSteel Collection

### Versioni e design di bordi in SolidSteel Collection



**Kante geschnitten ohne Fase (gebrochen)**  
**Bordo tagliato senza smusso (spezzato)**

Erhältlich für Oberfläche  
 Disponibile per superficie

Standard	BF	WF							
Spezial	ID	BI	BP	PL	XI	XF	XB	SL	WG



**Kante geschliffen ohne Fase (gebrochen)**  
**Bordo rettificato senza smusso (spezzato)**

Erhältlich für Oberfläche  
 Disponibile per superficie

Standard	BF	WF							
Spezial	ID	BI	BP	PL	XI	XF	XB	SL	WG



**Kante geschnitten mit Fase 0.5/45°**  
**Bordo tagliato con smusso 0.5/45°**  
**Kante geschnitten mit Fase oben und unten 0.5/45°**  
**Bordo tagliato con smusso superiore e inferiore 0.5/45°**

Erhältlich für Oberfläche  
 Disponibile per superficie

Standard	BF	WF							
Spezial	ID	BI	BP	PL	XI	XF	XB	SL	WG



**Kante geschliffen mit Fase 0.5/45°**  
**Bordo rettificato con smusso 0.5/45°**  
**Kante geschliffen mit Fase oben und unten 0.5/45°**  
**Bordo rettificato con smusso superiore e inferiore 0.5/45°**

Erhältlich für Oberfläche  
 Disponibile per superficie

Standard	BF	WF							
Spezial	ID	BI	BP	PL	XI	XF	XB	SL	WG



**Kante geschnitten mit Fase 1.0/45°**  
**Bordo tagliato con smusso 1.0/45°**  
**Kante geschnitten mit Fase oben 1.0 und unten 0.5/45°**  
**Bordo tagliato con smusso superiore 1.0 e inferiore 0.5/45°**

Erhältlich für Oberfläche  
 Disponibile per superficie

Standard	BF	WF							
Spezial	ID	BI	BP	PL	XI	XF	XB	SL	WG



**Kante geschliffen mit Fase 1.0/45°**  
**Bordo rettificato con smusso 1.0/45°**  
**Kante geschliffen mit Fase oben 1.0 und unten 0.5/45°**  
**Bordo rettificato con smusso superiore 1.0 e inferiore 0.5/45°**

Erhältlich für Oberfläche  
 Disponibile per superficie

Standard	BF	WF							
Spezial	ID	BI	BP	PL	XI	XF	XB	SL	WG

## SmartSteel Collection



## Kante A12/ Bordo A12

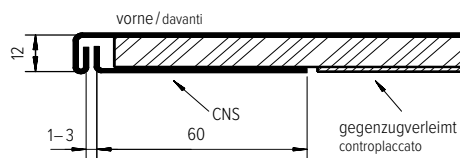

## Erhältliche Oberflächen

## Superfici disponibili

Standard SF BF WF

Decor  PS PB TR

Spezial XF

	Kantenausführung Lavorazione dei bordi	Kantendesign Design bordi	
	geschliffen rettificato	ohne Fase (Radius) senza smusso (raggio)	mit Fase con smusso
Standard	✓	✓	✓
Decor	✓	–	✓
Spezial	✓	–	✓

Weitere Produktinformationen / Altre informazioni prodotto 

 Nicht sichtbare Kanten werden ohne Bearbeitung ausgeführt.  
I bordi non a vista vengono eseguiti senza alcuna lavorazione.

## Kante A15/ Bordo A15

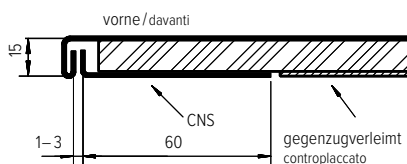

## Erhältliche Oberflächen

## Superfici disponibili

Standard SF BF WF

Decor  PS PB TR

Spezial XF

	Kantenausführung Lavorazione dei bordi	Kantendesign Design bordi	
	geschliffen rettificato	ohne Fase (Radius) senza smusso (raggio)	mit Fase con smusso
Standard	✓	✓	✓
Decor	✓	–	✓
Spezial	✓	–	✓

Weitere Produktinformationen / Altre informazioni prodotto 

 Nicht sichtbare Kanten werden ohne Bearbeitung ausgeführt.  
I bordi non a vista vengono eseguiti senza alcuna lavorazione.

**Kante A20 / Bordo A20**

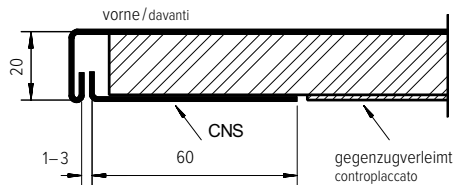

**Erhältliche Oberflächen**  
Superfici disponibili

Standard	SF	BF	WF
Decor	PS	PB	TR
Spezial	XF		

**Erhältliche Ausführung**  
Lavorazione disponibile



	Kantenausführung Lavorazione dei bordi		Kantendesign Design bordi	
	geschliffen rettificato	ohne Fase (Radius) senza smusso (raggio)	mit Fase con smusso	
Standard	✓	✓	✓	
Decor	✓	–	✓	
Spezial	✓	–	✓	

Weitere Produktinformationen / Altre informazioni prodotto 24

**i** Nicht sichtbare Kanten werden ohne Bearbeitung ausgeführt.  
I bordi non a vista vengono eseguiti senza alcuna lavorazione.

**Kante A20 Varix / Bordo A20 Varix**



**Erhältliche Oberflächen**  
Superfici disponibili

Standard	SF	BF	BX	WF
----------	----	----	----	----

	Kantenausführung Lavorazione dei bordi		Kantendesign Design bordi	
	geschliffen rettificato	ohne Fase (Radius) senza smusso (raggio)	mit Fase con smusso	
Standard	✓	✓	✓	

Weitere Produktinformationen / Altre informazioni prodotto 24

**i** Nicht sichtbare Kanten werden ohne Bearbeitung ausgeführt.  
I bordi non a vista vengono eseguiti senza alcuna lavorazione.

Schleifrichtungen Varix, s. Seite 33  
Direzione di rettifica Varix sulla pag. 33

## SmartSteel Collection

## Kante A30/Bordo A30

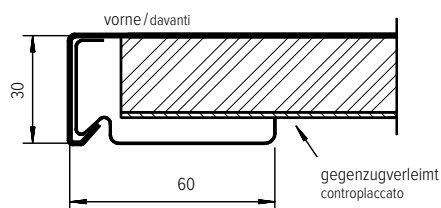
Erhältliche Oberflächen  
Superfici disponibili

Standard SF BF WF

Decor  PS PB TR

Spezial XF

Erhältliche Ausführung  
Lavorazione disponibile

	Kantenausführung Lavorazione dei bordi		Kantendesign Design bordi	
	geschliffen rettificato	ohne Fase (Radius) senza smusso (raggio)	mit Fase con smusso	
Standard	✓	✓	✓	
Decor	✓	–	✓	
Spezial	✓	–	✓	

Weitere Produktinformationen / Altre informazioni prodotto 

**i** Nicht sichtbare Kanten werden ohne Bearbeitung ausgeführt.  
I bordi non a vista vengono eseguiti senza alcuna lavorazione.

## Kante A30 Varix / Bordo A30 Varix

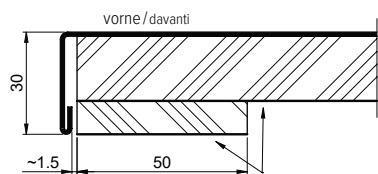

Spanplatte Kunstharz beschichtet, hellgrau  
Pannello truciolare rivestito di resina sintetica, grigio  
chiaro

Erhältliche Oberflächen  
Superfici disponibili

Standard SF BF BX WF

	Kantenausführung Lavorazione dei bordi		Kantendesign Design bordi	
	geschliffen rettificato	ohne Fase (Radius) senza smusso (raggio)	mit Fase con smusso	
Standard	✓	✓	✓	

Weitere Produktinformationen / Altre informazioni prodotto 

**i** Nicht sichtbare Kanten werden ohne Bearbeitung ausgeführt.  
I bordi non a vista vengono eseguiti senza alcuna lavorazione.

Schleifrichtungen Varix, s. Seite 33  
Direzione di rettifica Varix sulla pag. 33

**Kante A40 / Bordo A40**

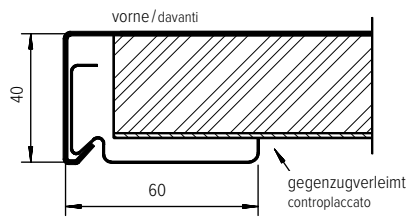

**Erhältliche Oberflächen**

**Superfici disponibili**

Standard	SF	BF	WF
Decor	PS	PB	TR
Spezial	XF		

	Kantenausführung Lavorazione dei bordi		Kantendesign Design bordi	
	geschliffen rettificato	ohne Fase (Radius) senza smusso (raggio)	mit Fase con smusso	
Standard	✓	✓	✓	
Decor	✓	–	✓	
Spezial	✓	–	✓	

Weitere Produktinformationen / Altre informazioni prodotto 24

**i** Nicht sichtbare Kanten werden ohne Bearbeitung ausgeführt.  
I bordi non a vista vengono eseguiti senza alcuna lavorazione.

**Kante A40 Varix / Bordo A40 Varix**

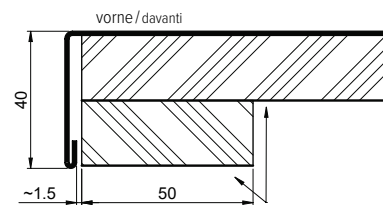

Spanplatte Kunstharz beschichtet, hellgrau  
Pannello truciolare rivestito di resina sintetica, grigio  
chiaro

**Erhältliche Oberflächen**

**Superfici disponibili**

Standard	SF	BF	BX	WF
----------	----	----	----	----

	Kantenausführung Lavorazione dei bordi		Kantendesign Design bordi	
	geschliffen rettificato	ohne Fase (Radius) senza smusso (raggio)	mit Fase con smusso	
Standard	✓	✓	✓	

Weitere Produktinformationen / Altre informazioni prodotto 24

**i** Nicht sichtbare Kanten werden ohne Bearbeitung ausgeführt.  
I bordi non a vista vengono eseguiti senza alcuna lavorazione.

Schleifrichtungen Varix, s. Seite 33  
Direzione di rettifica Varix sulla pag. 33

## SmartSteel Collection

Kante A50 – A100 / Bordo A50 – A100



### Erhältliche Oberflächen Superfici disponibili

Standard SF BF WF

	Kantenausführung Lavorazione dei bordi	Kantendesign Design bordi	
	geschliffen rettificato	ohne Fase (Radius) senza smusso (raggio)	mit Fase con smusso
Standard	✓	✓	✓

Weitere Produktinformationen / Altre informazioni prodotto  24

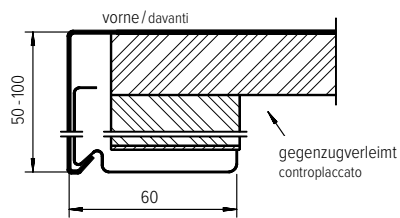

**i** Nicht sichtbare Kanten werden ohne Bearbeitung ausgeführt.  
I bordi non a vista vengono eseguiti senza alcuna lavorazione.

**Quetschkante A20 frontbündig / Bordo pressato a filo frontale A20**

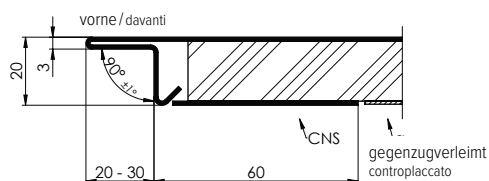

**Erhältliche Oberflächen  
Superfici disponibili**

Standard SF BF WF

**Erhältliche Ausführung  
Lavorazione disponibile**



	Kantenausführung Lavorazione dei bordi	Kantendesign Design bordi	
	geschliffen rettificato	ohne Fase (Radius) senza smusso (raggio)	mit Fase con smusso
Standard	✓	✓	–

Weitere Produktinformationen / Altre informazioni prodotto 24

**i** Quetschkante allseitig anwendbar. Rücksprung 20–30 mm (in mm Schritten) möglich.  
Bordo pressato applicabile su ogni lato. Possibile rientro di 20–30 mm (ad incrementi di 1 mm).

**Quetschkante A20 frontbündig Varix / Bordo pressato a filo frontale A20 Varix**

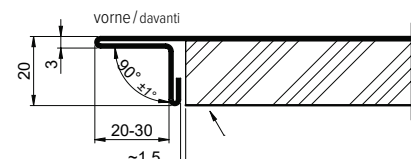

Spanplatte Kunstharz beschichtet, hellgrau  
Pannello truciolare rivestito di resina sintetica, grigio  
chiaro

**Erhältliche Oberflächen  
Superfici disponibili**

Standard SF BF BX WF

	Kantenausführung Lavorazione dei bordi	Kantendesign Design bordi	
	geschliffen rettificato	ohne Fase (Radius) senza smusso (raggio)	mit Fase con smusso
Standard	✓	✓	–

Weitere Produktinformationen / Altre informazioni prodotto 24

**i** Quetschkante vorne möglich. Andere Seiten nach Abklärung. Rücksprung 20–30 mm (in mm Schritten) möglich.  
Bordo pressato anteriore possibile. Altri lati dopo relativi chiarimenti. Rientro di 20 – 30 mm (con incrementi di mm) possibile.

Schleifrichtungen Varix, s. Seite 33  
Direzione di rettifica Varix sulla pag. 33

## SmartSteel Collection

## Quetschkante A30 frontbündig / Bordo pressato a filo frontale A30

Erhältliche Oberflächen  
Superfici disponibili

Standard SF BF WF

Erhältliche Ausführung  
Lavorazione disponibileKantenausführung  
Lavorazione dei bordigeschliffen  
rettificato

Standard

Kantendesign  
Design bordiohne Fase (Radius)  
senza smusso (raggio)mit Fase  
con smusso

-

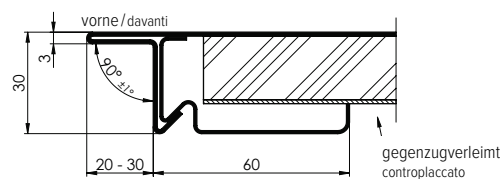

Weitere Produktinformationen / Altre informazioni prodotto 24

**i** Quetschkante allseitig anwendbar. Rücksprung 20–30 mm (in mm Schritten) möglich.  
Bordo pressato applicabile su ogni lato. Possibile rientro di 20–30 mm (ad incrementi di 1 mm).

## Quetschkante A30 frontbündig Varix / Bordo pressato a filo frontale A30 Varix

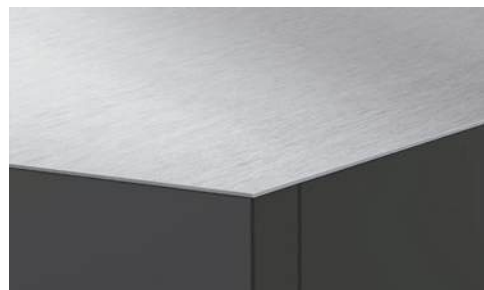
Erhältliche Oberflächen  
Superfici disponibili

Standard SF BF BX WF

Kantenausführung  
Lavorazione dei bordigeschliffen  
rettificato

Standard

Kantendesign  
Design bordiohne Fase (Radius)  
senza smusso (raggio)mit Fase  
con smusso

-

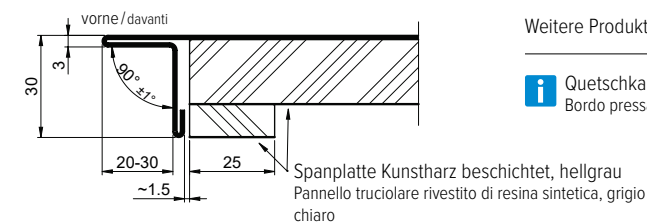

Weitere Produktinformationen / Altre informazioni prodotto 24

**i** Quetschkante vorne möglich. Andere Seiten nach Abklärung. Rücksprung 20–30 mm (in mm Schritten) möglich.  
Bordo pressato anteriore possibile. Altri lati dopo relativi chiarimenti. Rientro di 20–30 mm (con incrementi di mm) possibile.

**Quetschkante A40 frontbündig / Bordo pressato a filo frontale A40**



**Erhältliche Oberflächen  
Superfici disponibili**

Standard SF BF WF

Kantenausführung Lavorazione dei bordi	Kantendesign Design bordi	
	ohne Fase (Radius) senza smusso (raggio)	mit Fase con smusso
geschliffen rettificato	✓	–

Standard

Weitere Produktinformationen / Altre informazioni prodotto 24

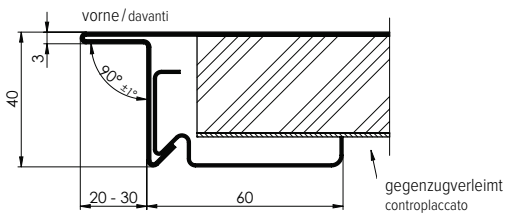

**i** Quetschkante allseitig anwendbar. Rücksprung 20–30 mm (in mm Schritten) möglich. Für Kantenausführung grösser als A40 auf Anfrage.

Bordo pressato applicabile su ogni lato. Possibile rientro di 20–30 mm (ad incrementi di 1 mm). Su richiesta, esecuzione di bordi maggiori di A40.

**Quetschkante A40 frontbündig Varix / Bordo pressato a filo frontale A40 Varix**



**Erhältliche Oberflächen  
Superfici disponibili**

Standard SF BF BX WF

Kantenausführung Lavorazione dei bordi	Kantendesign Design bordi	
	ohne Fase (Radius) senza smusso (raggio)	mit Fase con smusso
geschliffen rettificato	✓	–

Standard

Weitere Produktinformationen / Altre informazioni prodotto 24

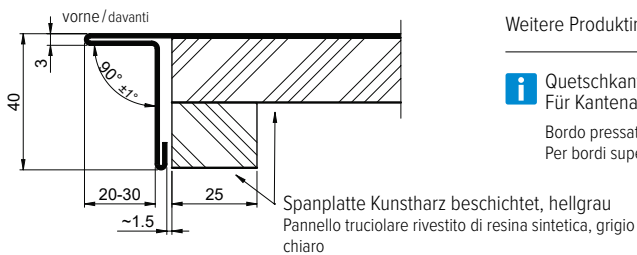

**i** Quetschkante vorne möglich. Andere Seiten nach Abklärung. Rücksprung 20–30 mm (in mm Schritten) möglich. Für Kantenausführung grösser als A40 auf Anfrage.

Bordo pressato anteriore possibile. Altri lati dopo relativi chiarimenti. Rientro di 20 – 30 mm (con incrementi di mm) possibile. Per bordi superiori ad A40 su richiesta.

## SmartSteel Collection

### Kante zum Anpassen A30GS – A100GS / Bordo da adattare A30GS – A100GS



#### Erhältliche Oberflächen Superfici disponibili

Standard SF BF WF

Weitere Produktinformationen / Altre informazioni prodotto  20

**i** Die Kantenausführungen A30GS – A100GS sind auf Wunsch zum Anpassen bauseits erhältlich.  
Lavorazioni di bordi A30GS – A100GS disponibili in versione adattabile a cura del committente.

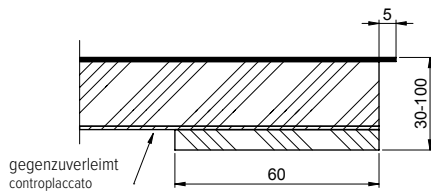

### Kante zum Anpassen A20GS – A40GS Varix / Bordo da adattare A20GS – A40GS Varix



#### Erhältliche Oberflächen Superfici disponibili

Standard SF BF BX WF

Weitere Produktinformationen / Altre informazioni prodotto  20

**i** Die Kantenausführungen A20GS – A40GS sind auf Wunsch zum Anpassen bauseits erhältlich.  
Nur seitlich eine Seite möglich.

Le bordature A20GS – A40GS sono disponibili su richiesta in versione adattabile a cura del cliente.  
Solo un lato possibile.

Schleifrichtungen Varix, s. Seite 33  
Direzione di rettifica Varix sulla pag. 33

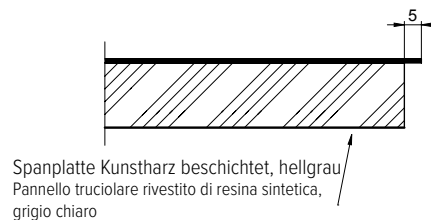

## SolidSteel Collection



### Kante M4 / Bordo M4



#### Erhältliche Oberflächen

##### Superfici disponibili

Standard BF WF

Spezial ID PL XI XF XB SL WG

	Kantenausführung Lavorazione dei bordi		Kantendesign Design bordi	
	geschnitten tagliato	geschliffen rettificato	ohne Fase (gebrochen) senza smusso (spezzato)	mit Fase con smusso
Standard	✓	✓	✓	✓
Spezial	✓	✓	✓	✓

Weitere Produktinformationen / Altre informazioni prodotto  24

**i** Montageempfehlung: Trägerplatte verwenden. Nicht sichtbare Kanten werden ohne Bearbeitung ausgeführt.  
Raccomandazione per il montaggio: utilizzare piastra di supporto. I bordi non a vista vengono eseguiti senza alcuna lavorazione.

### Kante M5 / Bordo M5



#### Erhältliche Oberflächen

##### Superfici disponibili

Standard BF

	Kantenausführung Lavorazione dei bordi		Kantendesign Design bordi	
	geschnitten tagliato	geschliffen rettificato	ohne Fase (gebrochen) senza smusso (spezzato)	mit Fase con smusso
Standard	✓	✓	✓	✓

Weitere Produktinformationen / Altre informazioni prodotto  24

**i** Montageempfehlung: Trägerplatte verwenden. Nicht sichtbare Kanten werden ohne Bearbeitung ausgeführt.  
Raccomandazione per il montaggio: utilizzare piastra di supporto. I bordi non a vista vengono eseguiti senza alcuna lavorazione.

## SolidSteel Collection

### Kante M8 / Bordo M8



#### Erhältliche Oberflächen

##### Superfici disponibili

Standard BF WF

Spezial ID BI BP PL SL WG

	Kantenausführung Lavorazione dei bordi		Kantendesign Design bordi	
	geschnitten tagliato	geschliffen rettificato	ohne Fase (gebrochen) senza smusso (spezzato)	mit Fase con smusso
Standard	✓	✓	✓	✓
Spezial	✓	✓	✓	✓

Weitere Produktinformationen / Altre informazioni prodotto 

**i** Montageempfehlung: Trägerplatte verwenden. Nicht sichtbare Kanten werden ohne Bearbeitung ausgeführt.  
Raccomandazione per il montaggio: utilizzare piastra di supporto. I bordi non a vista vengono eseguiti senza alcuna lavorazione.

### Kante M15-M300 / Bordo M15-M300



#### Erhältliche Oberflächen

##### Superfici disponibili

Standard BF WF

Spezial ID BI BP PL XI XF XB SL WG

Weitere Produktinformationen / Altre informazioni prodotto 

**i** Kante M15-M300 inklusive Unterkonstruktion. Die Kante ist in der Länge 3900-4980 mm erhältlich (siehe max. Länge Seite 24) Mehr Infos siehe suter.ch.  
Bordo M15-M300 con sottostruttura inclusa. Il bordo è disponibile in lunghezze da 3900-4980 mm (vedi dimensioni max. sulla pagina 24). Maggiori informazioni sono disponibili su suter.ch.

Schnitt A-A / Intaglio A-A

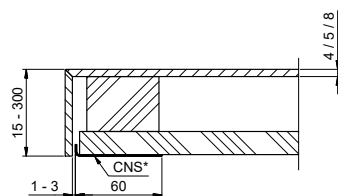
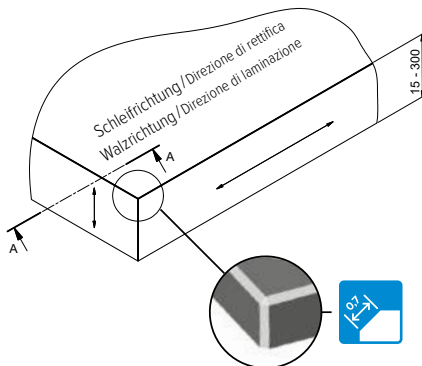

Zargenausführungen für / Versioni di telaio per **SmartSteel Collection**

Zarge Höhe H20 – H50 mm / Altezza telaio H20 – H50 mm

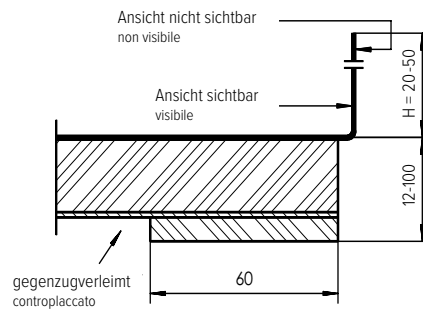
**Erhältliche Oberflächen**  
Superfici disponibili

Standard SF BF WF

**Erhältliche Ausführung**  
Lavorazione disponibile

Weitere Produktinformationen / Altre informazioni prodotto



**i** Für Fertigwände mit oder ohne Silikonabdichtung. Zargen höher als 50 mm auf Anfrage. Ohne Befestigungslöcher.

Per pareti finite con o senza guarnizione in silicone. Telai più alti di 50 mm solo su richiesta. Senza fori di fissaggio.

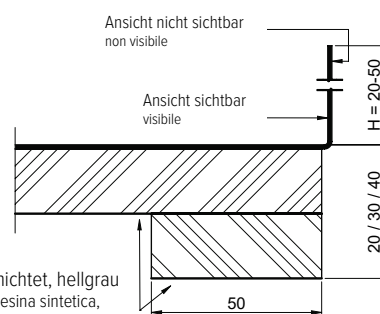
Zarge Höhe H20 – H50 mm **Varix** / Altezza telaio H20 – H50 mm Varix

Spanplatte Kunstharz beschichtet, hellgrau  
Pannello truciolare rivestito di resina sintetica,  
grigio chiaro

**Erhältliche Oberflächen / Superfici disponibili**

Standard SF BF BX WF

Weitere Produktinformationen / Altre informazioni prodotto



**i** Für Fertigwände mit oder ohne Silikonabdichtung. Ohne Befestigungslöcher.

Per pareti finite con o senza guarnizione in silicone. Senza fori di fissaggio.

Varix (BX) hinten möglich. Mehrseitig nach Abklärung. Varix (BX) possibile sul retro. Più lati dopo relativi chiarimenti.

Schleifrichtungen Varix, s. Seite 33  
Direzione di rettifica Varix sulla pag. 33

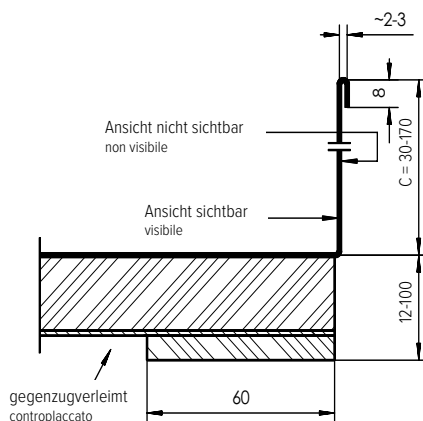

## Zarge C30-8 – C170-8 / Telaio C30-8 – C170-8

Erhältliche Oberflächen  
Superfici disponibili

Standard SF BF WF  
Spezial XF

Erhältliche Ausführung  
Lavorazione disponibile

Weitere Produktinformationen / Altre informazioni prodotto  20+22

**i** Für Fertigwände mit Silikonabdichtung.  
Zargenabschluss verschweisst auf Wunsch erhältlich.

Per pareti finite con guarnizione in silicone.  
Su richiesta, disponibilità di chiusura telaio saldata.

**XF** Nur hinten möglich.  
Seitlich nicht geschlossen.  
Mehrseitig nicht möglich.  
Zargenhöhe bis max 50.

Possibile solo sul retro.  
Non chiuso lateralmente.  
Non è possibile su più lati.  
Altezza telaio fino a max. 50.

## Zarge C30-8 – C50-8 Varix / Telaio C30-8 – C50-8 Varix

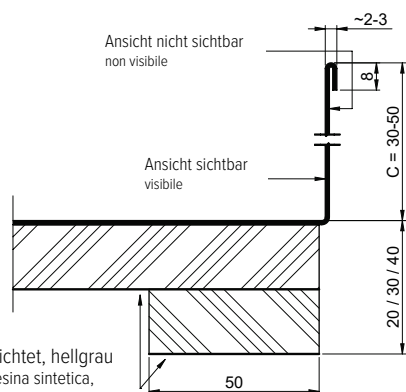

Spanplatte Kunstharz beschichtet, hellgrau  
Pannello truciolare rivestito di resina sintetica,  
grigio chiaro

## Erhältliche Oberflächen / Superfici disponibili

Standard SF BF BX WF

Weitere Produktinformationen / Altre informazioni prodotto  20

**i** Für Fertigwände mit Silikonabdichtung.  
Per pareti finite con guarnizione in silicone.

Nur hinten möglich.  
Seitlich nicht geschlossen.  
Mehrseitig nicht möglich.

Possibile solo sul retro.  
Non chiuso lateralmente.  
Non è possibile su più lati.

Schleifrichtungen Varix, s. Seite 33  
Direzione di rettifica Varix sulla pag. 33

Zargenausführungen für / Versioni di telaio per **SmartSteel Collection**

Zarge C30-D-90° – C170-D-90° / Telaio C30-D-90° – C170-D-90°

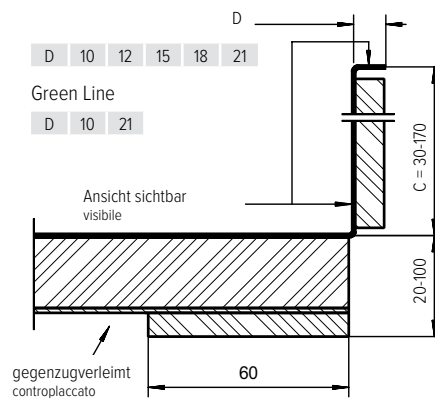
**Erhältliche Oberflächen**  
Superfici disponibili

Standard SF BF WF

**Erhältliche Ausführung**  
Lavorazione disponibile

Weitere Produktinformationen / Altre informazioni prodotto



**i** Für fugenlose Stehborde oder Rückwand.  
Mit Holzaufdoppelung. Zargenabschluss  
verschweisst auf Wunsch erhältlich.

Per sponde verticali senza giunti o pannello posteriore.  
Con riporto in legno. Su richiesta,  
disponibilità di chiusura telaio saldata.

Zarge C30-D-90° – C50-D-90° Varix / Telaio C30-D-90° – C50-D-90° Varix



D 11 20

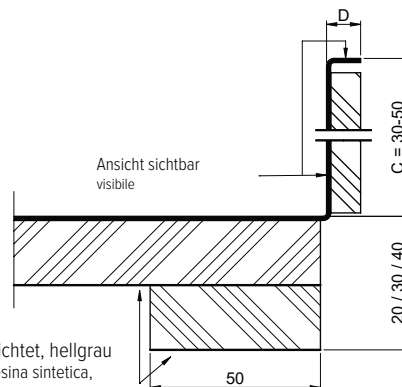

Spanplatte Kunstharz beschichtet, hellgrau  
Pannello truciolare rivestito di resina sintetica,  
grigio chiaro

**Erhältliche Oberflächen / Superfici disponibili**

Standard SF BF BX WF

Weitere Produktinformationen / Altre informazioni prodotto



**i** Für fugenlose Stehborde oder Rückwand.  
Mit Holzaufdoppelung.

Per sponde verticali senza giunti o pannello posteriore.  
Con riporto in legno.

Nur hinten möglich.  
Seitlich nicht geschlossen.  
Mehrseitig nicht möglich.

Possibile solo sul retro.  
Non chiuso lateralmente.  
Non è possibile su più lati.

Schleifrichtungen Varix, s. Seite 33  
Direzione di rettifica Varix sulla pag. 33

## Zarge C30-D-90° – C170-D-90° hinten sichtbar / Telaio C30-D-90° – C170-D-90° visibile sul retro

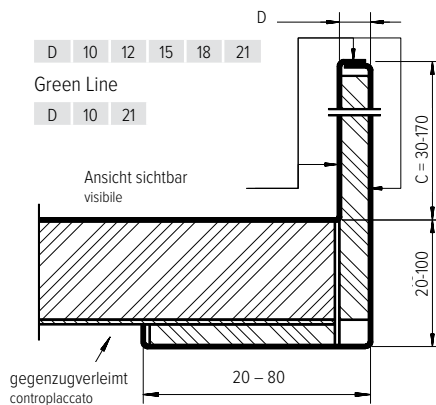
Erhältliche Oberflächen  
Superfici disponibili

Standard SF BF WF

Erhältliche Ausführung  
Lavorazione disponibileWeitere Produktinformationen / Altre informazioni prodotto 

**i** Für freistehende Anwendungen. Mit Holzaufdoppelung. Zargenabschluss verschweisst auf Wunsch erhältlich.

Per impieghi a posa libera. Con riporto in legno. Su richiesta, disponibilità di chiusura telaio saldata.

## Zarge C30-D-90° – C50-D-90° hinten sichtbar Varix / Telaio C30-D-90° – C50-D-90° visibile sul retro Varix

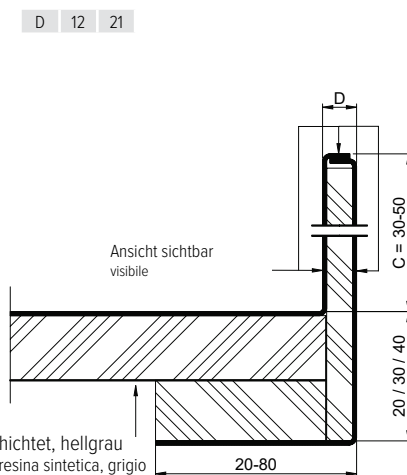

## Erhältliche Oberflächen / Superfici disponibili

Standard SF BF BX WF

Weitere Produktinformationen / Altre informazioni prodotto 

**i** Für freistehende Anwendungen. Mit Holzaufdoppelung. Per impieghi a posa libera. Con riporto in legno.

Nur hinten möglich.  
Seitlich nicht geschlossen.  
Mehrseitig nicht möglich.

Possibile solo sul retro.  
Non chiuso lateralmente.  
Non è possibile su più lati.

Schleifrichtungen Varix, s. Seite 33  
Direzione di rettifica Varix sulla pag. 33

## Sickenausführungen / Lavorazioni con nervatura

Sicke 1,5 mm / Nervatura 1,5 mm



**Erhältliche Ausführung / Lavorazione disponibile**

SmartSteel Collection



SolidSteel Collection



**Erhältliche Oberflächen / Superfici disponibili**

Standard SF WF

Weitere Produktinformationen / Altre informazioni prodotto 

**i** Für Kantenhöhe A12 – A100 ohne Gefälle erhältlich.  
L- und U-Winkel Massanfertigungsformen geschweisst oder gesteckt möglich.  
Disponibile per altezze di bordo A12 – A100 e senza pendenza.  
Possibilità di forme lavorate su misura a «L» e a «U», saldate o ad innesto.

Minimalmasse / Misure minime

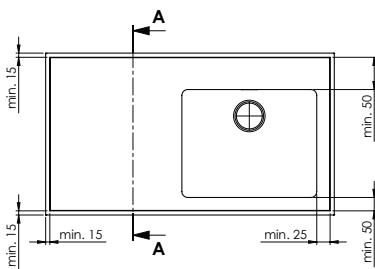

Schnitt A-A / Intaglio A-A

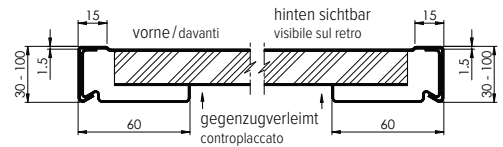
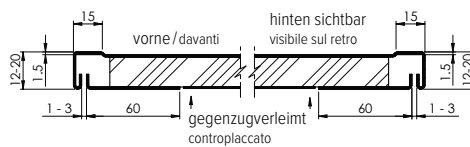

Sicke 10 mm / Nervatura 10 mm



**Erhältliche Ausführung / Lavorazione disponibile**

SmartSteel Collection

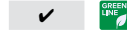

SolidSteel Collection



**Erhältliche Oberflächen / Superfici disponibili**

Standard SF WF

Weitere Produktinformationen / Altre informazioni prodotto 

**i** Für Kantenhöhe A20 – A100 ohne Gefälle erhältlich. Nur einzeilige Massanfertigungsformen möglich.  
Disponibile per altezze di bordo A20 – A100 senza pendenza. Possibilità di forme lavorate su misura solo su una linea.

Minimalmasse / Misure minime

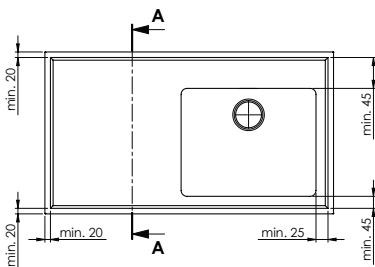

Schnitt A-A / Intaglio A-A

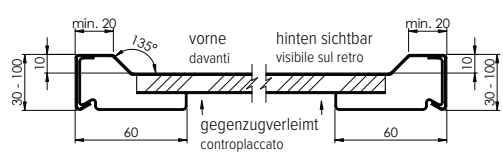
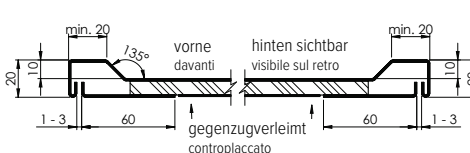

## Übersicht Beckeneinbauvarianten / Varianti di montaggio ad incasso del lavello



Einbauvariante Variante di montaggio	Beckenübergang Punto di raccordo lavello	SmartSteel Collection	SolidSteel Collection	Erhältlich für Oberfläche Disponibile per superficie
1 Flächenbündig Filo top	Standard-Fase Smusso standard	✓	–	Standard SF BF BX WF Decor  PS PB TR Spezial XF
2 Flächenbündig Filo top	Standard-Fase Smusso standard	–	✓	Standard BF WF Spezial ID BI BP PL XI XF XB SL WG
3 Flächenbündig Filo top	Design-Fase 1.0/45° Smusso Design 1.0/45°	✓	✓	Standard BF WF
4 Unterbau Sottopiano	Kante mit Fase 1.0/45° Bordo con smusso 1.0/45°	–	✓	Standard BF WF Spezial ID BI BP PL XI XF XB SL WG

Kochfelder / Piani cottura



Massanfertigungen  
Soluzioni a misura

**Einbauvariante für Kochfelder mit Auflagerahmen / Variante da incasso per piani cottura con telaio in appoggio**

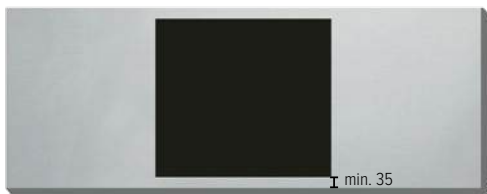

SmartSteel Collection  
Mass variabel nach Kochfeld-Hersteller  
dimensioni variabili in base al produttore del piano cottura

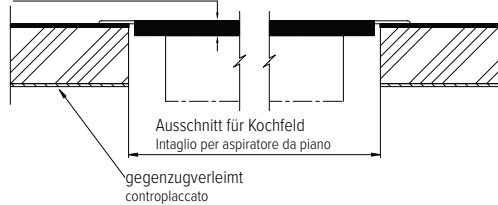

SolidSteel Collection  
Mass variabel nach Kochfeld-Hersteller  
dimensioni variabili in base al produttore del piano cottura

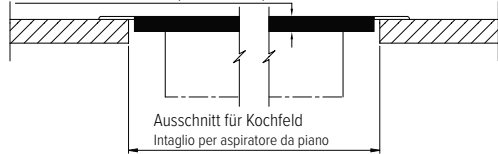

**Erhältliche Ausführung / Lavorazione disponibile**

SmartSteel Collection   SolidSteel Collection

**Erhältliche Oberflächen / Superfici disponibili**

- Standard SF BF WF  
Decor  PS PB TR  
Spezial ID BI BP PL XI XF XB SL WG

Weitere Produktinformationen / Altre informazioni prodotto  20-23

**i** Zur Vermeidung von Transportschäden bei der Ausführung SmartSteel Collection ist die durchgehende Spanplatte inkl. Gegenzugverleimung bauseits zu entfernen. Dies kann mit einem normalen Holzsägeblatt bewerkstelligt werden.  
Per evitare danni durante il trasporto, il pannello in truciolato comprensivo di controplaccatura dev'essere rimosso sul posto.  
Per farlo è possibile utilizzare una normale sega per legno.

**Einbauvariante für Kochfelder mit Auflagerahmen Varix / Variante da incasso per piani cottura con telaio in appoggio Varix**

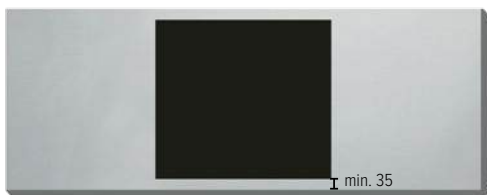

Mass variabel nach Kochfeld-Hersteller  
dimensioni variabili in base al produttore del piano cottura



**Erhältliche Ausführung / Lavorazione disponibile**

SmartSteel Collection  SolidSteel Collection

**Erhältliche Oberflächen / Superfici disponibili**

- Standard SF BF BX WF

Weitere Produktinformationen / Altre informazioni prodotto  20

**i** Zur Vermeidung von Transportschäden bei der Ausführung SmartSteel Collection ist die durchgehende Spanplatte bauseits zu entfernen. Dies kann mit einem normalen Holzsägeblatt bewerkstelligt werden.  
Per evitare danni durante il trasporto, il pannello in truciolato dev'essere rimosso sul posto. Per farlo è possibile utilizzare una normale sega per legno.

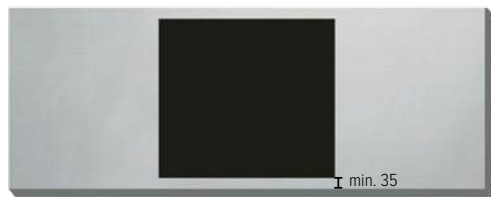
**Einbauvariante für Kochfelder flächenbündig eingebaut / Variante da incasso per piani cottura montati a filo top**

**Erhältliche Ausführung / Lavorazione disponibile**

SmartSteel Collection



SolidSteel Collection

**Erhältliche Oberflächen / Superfici disponibili**

Standard

SF BF WF

Decor



PS PB TR

Spezial

ID BI BP PL XI XF XB SL WG

SmartSteel Collection

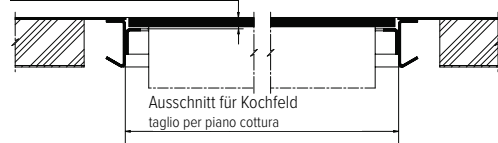
 Mass variabel nach Kochfeld-Hersteller  
 dimensioni variabili in base al produttore del piano cottura

SolidSteel Collection

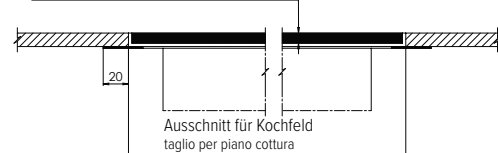
 Mass variabel nach Kochfeld-Hersteller  
 dimensioni variabili in base al produttore del piano cottura

Weitere Produktinformationen / Altre informazioni prodotto 20-23

**i** Kochfeldrahmenaufbau bei Trägerplatte und Küchenmöbel beachten.  
 Nel montaggio del telaio per piano di cottura, prestare attenzione alla piastra di supporto e al mobilio della cucina.

**Einbauvariante für Kochfelder flächenbündig eingebaut Varix / Variante da incasso per piani cottura montati a filo top Varix**

**Erhältliche Ausführung / Lavorazione disponibile**

SmartSteel Collection



SolidSteel Collection

**Erhältliche Oberflächen / Superfici disponibili**

Standard

SF BF BX WF

Weitere Produktinformationen / Altre informazioni prodotto 20

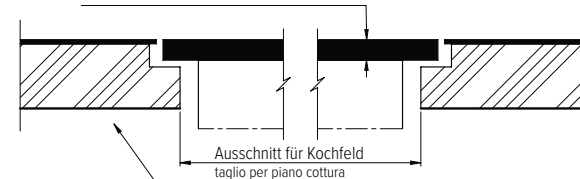
 Mass variabel nach Kochfeld-Hersteller  
 dimensioni variabili in base al produttore del piano cottura

 Spanplatte Kunstharz beschichtet, hellgrau  
 Pannello truciolare rivestito di resina sintetica, grigio  
 chiaro

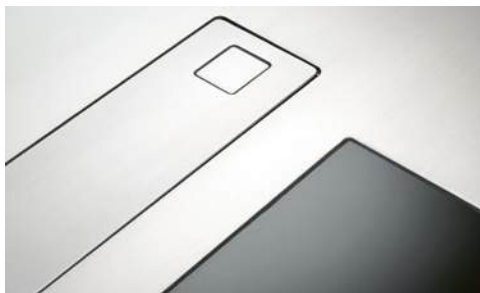
## Ausschnitt für Kochfeldabzug mit Auflagerahmen / Intaglio per aspiratore da piano con telaio in appoggio

**Erhältliche Ausführung / Lavorazione disponibile**

SmartSteel Collection



SolidSteel Collection

**Erhältliche Oberflächen / Superfici disponibili**

Standard

SF BF WF

Decor

PS PB TR

Spezial

ID BI BP PL XI XF XB SL WG

Weitere Produktinformationen / Altre informazioni prodotto



- i** Ausschnitt für SmartSteel Collection mit oder ohne Verkleidung möglich.  
 Ausschnitt aus derselben Oberfläche wird mitgeliefert.  
 Possibile intaglio per SmartSteel Collection con o senza rivestimento.  
 Viene fornito un intaglio della stessa superficie.

## Rückwände, Seitenwände / Pannelli posteriori, pannelli laterali



## Rück- und Seitenwände mehrteilig / Pannelli posteriori e fianchi in più parti



Schnitt A-A / Intaglio A-A

SmartSteel Collection

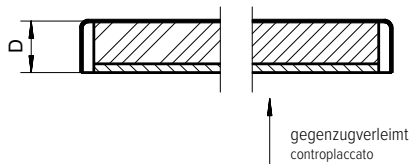

SolidSteel Collection

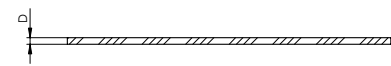

## Erhältliche Ausführung / Lavorazione disponibile

SmartSteel Collection



SolidSteel Collection



## Erhältliche Oberflächen / Superfici disponibili

Standard

SF BF WF

Decor



PS PB TR

Spezial

ID BI BP PL XI XF XB SL WG



Kantenhöhe (D) Altezza di bordo (D)	max. Länge (L) / Lunghezza max (L)	max. Höhe (H) / Altezza max (H)
10	2500	1400
21	3900	1400

Weitere Produktinformationen / Altre informazioni prodotto



## SmartSteel Collection

Kantenhöhe (D) Altezza di bordo (D)	max. Länge (L) / Lunghezza max (L)		max. Höhe (H) / Altezza max (H)	
	Standardoberflächen Superfici standard	Decor Oberflächen und XF Superfici Decor e XF	Standardoberflächen Superfici standard	Decor Oberflächen und XF Superfici Decor e XF
10	2500	2500	1750	1400
12/15/18/21	6000	3900	1750	1400

## SolidSteel Collection

Kantenhöhe (D) Altezza di bordo (D)	max. Länge (L) / Lunghezza max (L)		max. Höhe (H) / Altezza max (H)	
	Standardoberflächen <sup>1</sup> Superfici standard <sup>1</sup>	Spezialoberflächen <sup>1</sup> Superfici speciali <sup>1</sup>	Standardoberflächen <sup>1</sup> Superfici standard <sup>1</sup>	Spezialoberflächen <sup>1</sup> Superfici speciali <sup>1</sup>
4/5/8	3980–4980 <sup>1</sup>	3900–4950 <sup>1</sup>	1980 <sup>1</sup>	1400–1480 <sup>1</sup>

<sup>1</sup> Verfügbare Oberflächen und Abmessungen siehe Seite<sup>1</sup> Per la disponibilità di superfici e misure, vedi alla pagina

**Rück- und Seitenwände mehrteilig Varix / Pannelli posteriori e fianchi in più parti Varix**

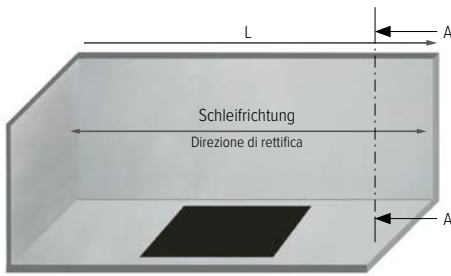

**Erhältliche Ausführung / Lavorazione disponibile**

SmartSteel Collection  SolidSteel Collection

**Erhältliche Oberflächen / Superfici disponibili**

Standard  SF  BF  BX  WF

Weitere Produktinformationen / Altre informazioni prodotto  20

Schnitt A-A / Intaglio A-A

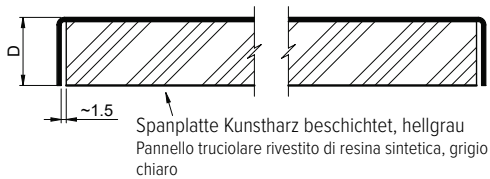

SmartSteel Collection

Kantenhöhe (D) Altezza di bordo (D)	max. Länge (L) / Lunghezza max (L)		max. Höhe (H) / Altezza max (H)	
	Varix		Varix	
11	2500		1400	
20	3900		1400	

**Rück- und Seitenwände mehrteilig 1.5 mm / Pannelli posteriori e fianchi in più parti 1.5 mm**



**Erhältliche Ausführung / Lavorazione disponibile**

SmartSteel Collection  SolidSteel Collection

**Erhältliche Oberflächen / Superfici disponibili**

Standard  SF  BF  WF

Weitere Produktinformationen / Altre informazioni prodotto  20

Schnitt A-A / Intaglio A-A



**i** Ferritischer Chrom Edelstahl, magnetisierbar. Im Preis inklusiv: Erster Steckdosenausschnitt, schräge Kanten, mittlerer Ausschnitt und Eckausschnitt.

Acciaio ferritico (al cromo), magnetizzabile. Inclusi nel prezzo: primo intaglio per presa elettrica, taglio inclinato bordi, intaglio intermedio e intaglio angolare.

## Tablare, Fronten und Sockelbleche / Ripiani, frontali e zoccolature



## Tablare / Ripiani

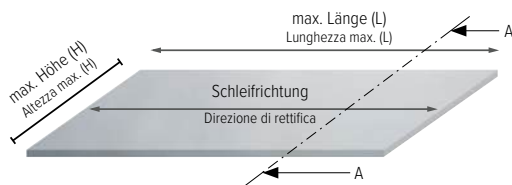

Schnitt A-A / Intaglio A-A

## SmartSteel Collection

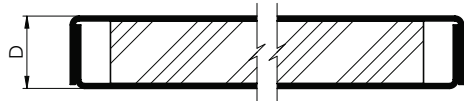

## SolidSteel Collection

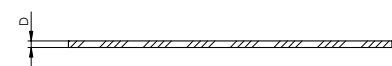

## Erhältliche Ausführung / Lavorazione disponibile

SmartSteel Collection



SolidSteel Collection



## Erhältliche Oberflächen / Superfici disponibili

Standard

SF BF WF

Spezial

ID BI BP PL XI XF XB SL WG

Weitere Produktinformationen / Altre informazioni prodotto



## SmartSteel Collection

Kantenhöhe (D) Altezza di bordo (D)	max. Länge (L) Lunghezza max. (L)	max. Tiefe (H) Profondità max. (H)
15	2500	600
18/24/27	6000	1200

## SolidSteel Collection

Kantenhöhe (D) Altezza di bordo (D)	max. Länge (L) Lunghezza max. (L)	max. Höhe (H) Altezza max. (H)
4/5/8	3900-4980	1400-1980

**i** SolidSteel Spezial Oberflächen: Unabhängig von der Ausführung und der Oberfläche wird die sichtbare Unterseite in der Oberfläche Breitband-Finish ausgeführt. Situativ wird in Abhängigkeit von der Länge eine zusätzliche Abstützung empfohlen.

SolidSteel superfici speciali: Indipendentemente dal tipo di esecuzione e dalla superficie, il lato inferiore a vista viene eseguito con finitura superficiale a nastro largo. A seconda della lunghezza, si raccomanda l'uso di un supporto supplementare.

## Fronten einbaufertig / Frontali pronti per il montaggio

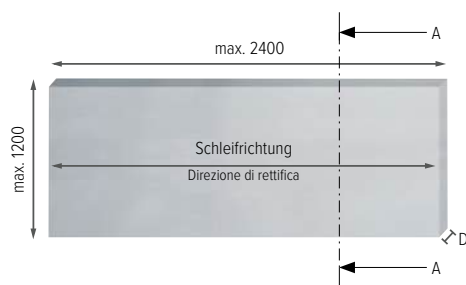

Schnitt A-A / Intaglio A-A

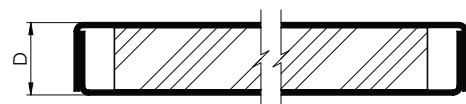

D 15.5 18.5

## Erhältliche Ausführung / Lavorazione disponibile

SmartSteel Collection



SolidSteel Collection



## Erhältliche Oberflächen / Superfici disponibili

Standard

SF BF WF

Weitere Produktinformationen / Altre informazioni prodotto

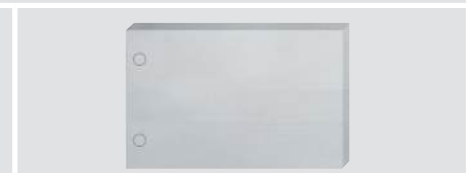
Erhältliche Bohrungen  
Forature disponibiliLochbohrung für Fronten  $\varnothing$  3-65 mm  
Foratura sul frontale  $\varnothing$  3-65 mmBandbohrung in Fronten  
Foratura per cerniere sul frontale

Fronten zum Anpassen / Adattare i frontali



D 15.5 18.5

Empfohlener bauseitiger Arbeitsvorgang  
Procedura raccomandata da eseguire

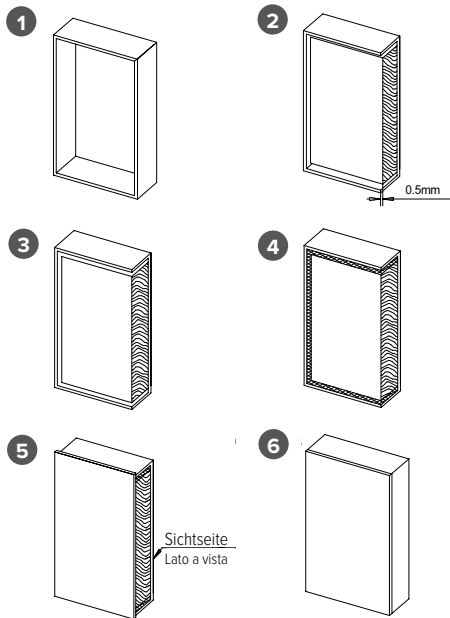

- 1 Schale ohne Holz / Struttura senza legno
- 2 Holz zurückstehend einleimen / Incollare il legno con un margine rientrante
- 3 Blechplan schleifen / Rettificare in piano la lamiera
- 4 Spalt mit Silikon auffüllen / Riempire il margine con silicone
- 5 Rückseite beschichten / Ricoprire il lato posteriore
- 6 Vorstehende Kante abschleifen / Rimuovere il bordo sporgente anteriore

Erhältliche Ausführung / Lavorazione disponibile

SmartSteel Collection

SolidSteel Collection

Erhältliche Oberflächen / Superfici disponibili

Standard  SF  BF  WF

Weitere Produktinformationen / Altre informazioni prodotto 20

Erhältliche Bohrungen  
Forature disponibili



Lochbohrung für Fronten  $\varnothing$  3–65 mm  
Foratura sul frontale  $\varnothing$  3–65 mm

**i** Empfohlener bauseitiger Arbeitsvorgang für Weiterverarbeitung von Fronten ohne eingeklebte Holzplatte.  
Procedura raccomandata da eseguire sul posto per la rifinitura di frontali senza pannello in legno incollato.

## Sockelbleche / Lamiere per zoccoli

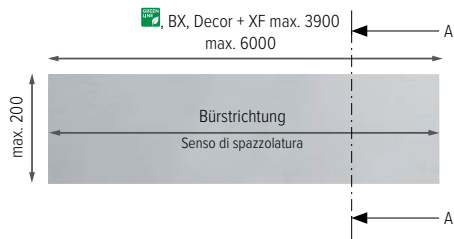

Schnitt A-A / Intaglio A-A

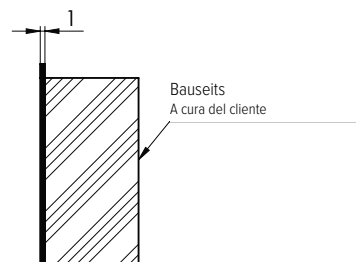

## Erhältliche Ausführung / Lavorazione disponibile

SmartSteel Collection



SolidSteel Collection



## Erhältliche Oberflächen / Superfici disponibili

Standard SF BF BX WF

Decor  PS PB TR

Spezial XF

Weitere Produktinformationen / Altre informazioni prodotto Erhältliche Ausführungen  
Versioni disponibili

Abkantung / Piegature

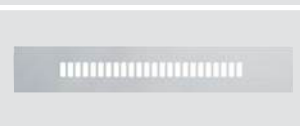
Lüftungsöffnung nach Vorgabe.  
Apertura per ventilazione secondo specifica.

Ausschnitt / Taglio



 Massgenau zugeschnittene Edelstahlblenden, zwecks bauseitiger Aufleimung auf Küchensockel.  
Abkantungen nur für Standardoberflächen erhältlich.

Lamiere in acciaio tagliate su misura da incollare in loco sullo zoccolo della cucina.  
Piegature disponibili solo per superfici standard.

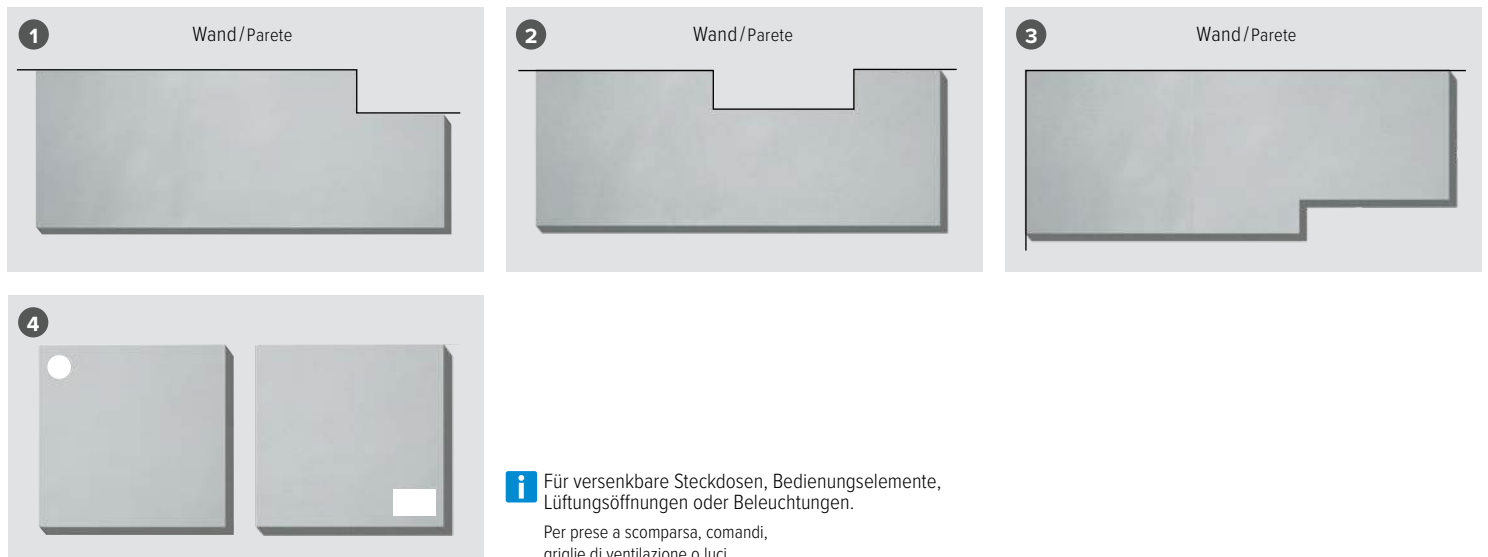
## Ausschnitte / Intagli



**i** Für versenkbare Steckdosen, Bedienelemente, Lüftungsöffnungen oder Beleuchtungen.  
Per prese a scomparsa, comandi, griglie di ventilazione o luci.

Ausschnitt Intaglio	Erhältlich für Oberfläche Disponibile per superficie	SmartSteel Collection			SolidSteel Collection	
		Kanten Bordi	Zarge Telaio	Geschnitten Tagliato	Geschnitten Tagliato	Geschliffen Rettificato
1 Eckausschnitt wandseitig Intaglio angolare lato parete	Standard SF BF WF	✓ GREEN LINE	✓ GREEN LINE	✓ GREEN LINE	✓	–
	Decor  PS PB TR Varix BX	–	–	✓	–	–
	Spezial ID BI BP PL XI XF XB SL WG	–	–	✓	✓	–
2 Wandseitiger Ausschnitt Intaglio lato parete	Standard SF BF WF	✓ GREEN LINE	✓ GREEN LINE	✓ GREEN LINE	✓	–
	Decor  PS PB TR Varix BX	–	–	✓	–	–
	Spezial ID BI BP PL XI XF XB SL WG	–	–	✓	✓	–
3 Frontseitiger Ausschnitt Intaglio lato frontale	Standard SF BF WF	✓ GREEN LINE	–	–	✓	✓
	Spezial ID BI BP PL XI XF XB SL WG	–	–	–	✓	✓
4 Ausschnitt rund oder eckig Intaglio rotondo o angolare	Standard SF BF WF	✓ GREEN LINE	✓ GREEN LINE	✓ GREEN LINE	✓	–
	Decor  PS PB TR Varix BX	–	–	✓	–	–
	Spezial ID BI BP PL XI XF XB SL WG	–	–	✓	✓	–

**i** Standardoberfläche Seidenmatt-Finish für die Ausführung SolidSteel Collection nicht erhältlich.  
Nella versione SolidSteel Collection, la superficie standard con finitura satinata non è disponibile.

## Schrägen / Tagli inclinati

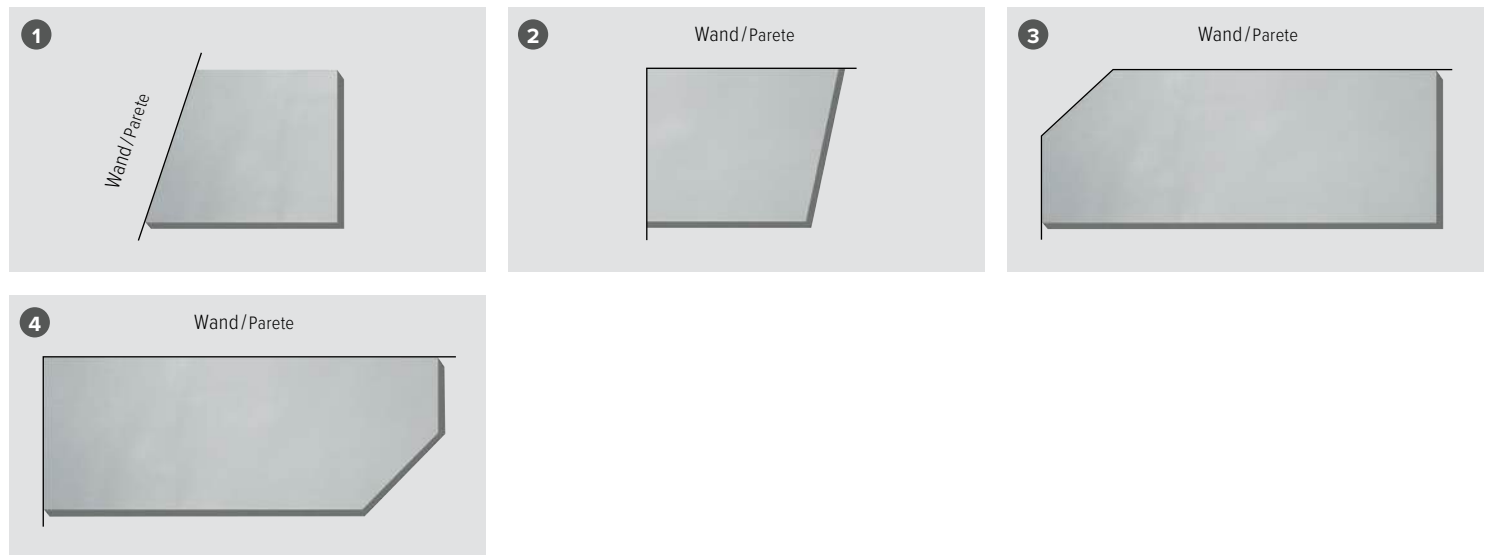

Schräge Taglio inclinato	Erhältlich für Oberfläche Disponibile per superficie	SmartSteel Collection			SolidSteel Collection						
		Kanten Bordi	Zarge Telaio	Geschnitten Tagliato	Geschnitten Tagliato	Geschliffen Rettificato					
1 Wandseitig offener oder geschlossener Winkel Angolo aperto o chiuso lato parete	Standard	SF	BF	WF	✓	GREEN LINE	✓	GREEN LINE	✓	–	
	Decor	PS	PB	TR	Varix	BX	✓	–	✓	–	
	Spezial	ID	BI	BP	PL	XI	XF	XB	SL	WG	✓
2 Frontseitig offener oder geschlossener Winkel Angolo aperto o chiuso lato frontale	Standard	SF	BF	WF	✓	GREEN LINE	–	–	✓	✓	
	Decor	PS	PB	TR	Varix	BX	✓	–	–	–	
	Spezial	ID	BI	BP	PL	XI	XF	XB	SL	WG	✓
3 Eckschräge wandseitig Taglio inclinato angolare lato parete	Standard	SF	BF	WF	✓	GREEN LINE	✓	GREEN LINE	✓	GREEN LINE	–
	Decor	PS	PB	TR	Varix	BX	–	–	✓	–	–
	Spezial	ID	BI	BP	PL	XI	XF	XB	SL	WG	–
4 Eckschräge frontseitig Taglio inclinato angolare lato frontale	Standard	SF	BF	WF	✓	GREEN LINE	–	–	✓	✓	
	Spezial	ID	BI	BP	PL	XI	XF	XB	SL	WG	–

Standardoberfläche Seidenmatt-Finish für die Ausführung SolidSteel Collection nicht erhältlich.  
Nella versione SolidSteel Collection, la superficie standard con finitura satinata non è disponibile.

## Rundungen / Curvatura

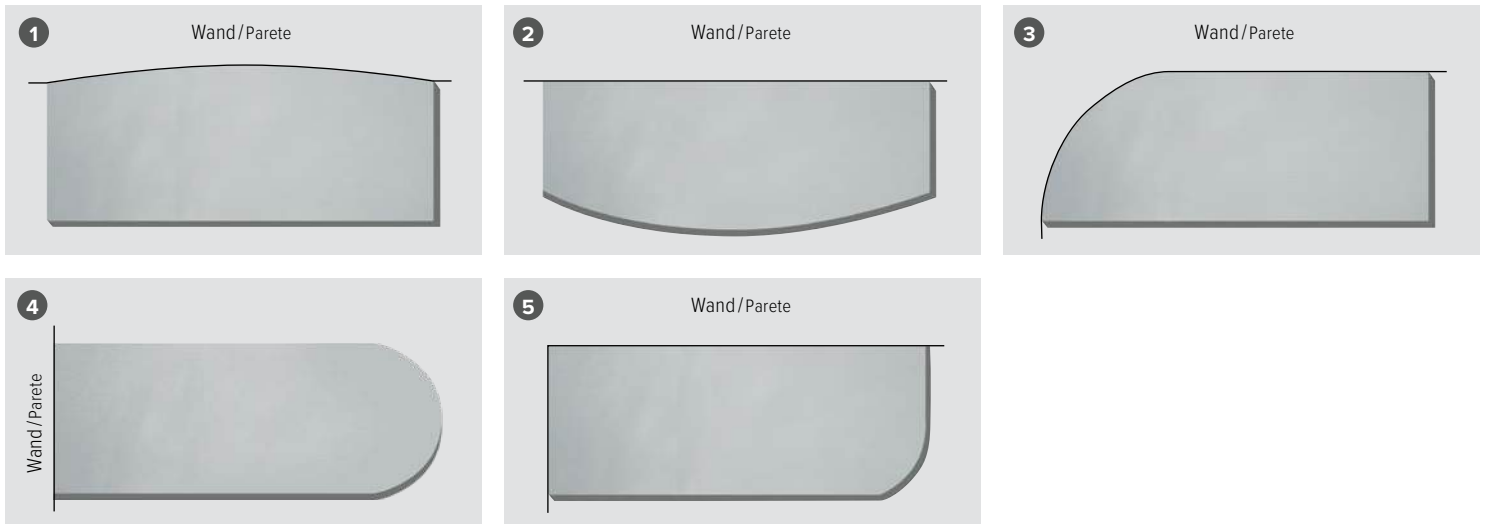

Rundung Curvatura	Erhältlich für Oberfläche Disponibile per superficie	SmartSteel Collection			SolidSteel Collection	
		Kanten Bordi	Zarge Telaio	Geschnitten Tagliato	Geschnitten Tagliato	Geschliffen Rettificato
1 Flache Rundung wandseitig Curvatura piatta lato parete	Standard SF BF WF	✓ GREEN LINE	–	✓ GREEN LINE	✓	–
	Decor  PS PB TR Varix BX	–	–	✓	–	–
	Spezial ID BI BP PL XI XF XB SL WG	–	–	✓	✓	–
2 Flache Rundung frontseitig Curvatura piatta lato frontale	Standard SF BF WF	✓ GREEN LINE	–	–	✓	✓
	Spezial ID BI BP PL XI XF XB SL WG	–	–	–	✓	✓
3 Wandseitig abgerundet Curvatura lato parete	Standard SF BF WF	✓ GREEN LINE	–	✓ GREEN LINE	✓	–
	Decor  PS PB TR Varix BX	–	–	✓	–	–
	Spezial ID BI BP PL XI XF XB SL WG	–	–	✓	✓	–
4 Ganze Rundung stirnseitig Stondatura completa frontale	Standard SF BF WF	✓ GREEN LINE	–	–	✓	✓
	Spezial ID BI BP PL XI XF XB SL WG	–	–	–	✓	✓
5 Halbe Rundung frontseitig Semi-stondatura frontale	Standard SF BF WF	✓ GREEN LINE	–	–	✓	✓
	Spezial ID BI BP PL XI XF XB SL WG	–	–	–	✓	✓

**i** Standardoberfläche Seidenmatt-Finish für die Ausführung SolidSteel Collection nicht erhältlich.  
Nella versione SolidSteel Collection, la superficie standard con finitura satinata non è disponibile.

## Verbindung von mehrteiligen Oberflächen / Giunzione di superfici in più parti

### Verbindung «Stabilo» A12-A19 / Giunto a innesto «Stabilo» A12-A19



#### Erhältliche Ausführung / Lavorazione disponibile

SmartSteel Collection



SolidSteel Collection



#### Erhältliche Oberflächen / Superfici disponibili

Standard SF BF WF

Decor  PS PB TR

Spezial XF

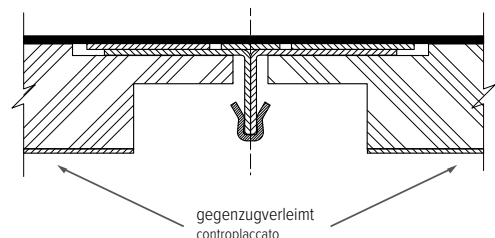
Weitere Produktinformationen / Altre informazioni prodotto  20-23

**i** Für Kantenhöhen A12–A19 erhältlich. Die Stecknaht ist bauseits gut abzustützen. Positionierung der Nahtstelle nach Vorgaben im freien Winkel oder in der Gehrung möglich. Feder für Verbindung wird lose mitgeliefert.

Disponibile per altezze di bordo A12–A19. Il giunto ad innesto dev'essere supportato in loco. Possibile posizionamento del punto di giunzione come da specifica, ad angolo aperto o nello smusso. La linguetta per il collegamento viene fornita sfusa.

### Verbindung «Stabilo» A20–A100 / Giunto a innesto «Stabilo» A20-A100



#### Erhältliche Ausführung / Lavorazione disponibile

SmartSteel Collection



SolidSteel Collection



#### Erhältliche Oberflächen / Superfici disponibili

Standard SF BF BX WF

Decor  PS PB TR

Spezial XF

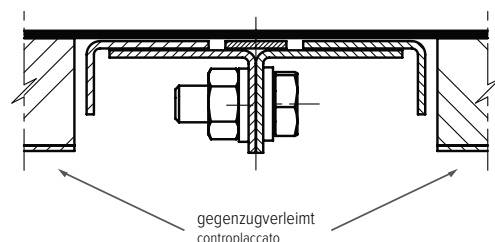
Weitere Produktinformationen / Altre informazioni prodotto  20-23

**i** Für Kantenhöhen A20–A100 erhältlich. Die Stecknaht ist bauseits gut abzustützen. Die Schrauben sind nur leicht anzustellen. Positionierung der Nahtstelle nach Vorgaben im freien Winkel oder in der Gehrung möglich. Feder für Verbindung wird lose mitgeliefert.

Disponibile per altezze di bordo A20–A100. Il giunto ad innesto dev'essere supportato in loco. Le viti devono essere serrate solo leggermente. Possibile posizionamento del punto di giunzione come da specifica, ad angolo aperto o nello smusso. La linguetta per il collegamento viene fornita sfusa.

Verbindung «Stoss» / Giunti di testa

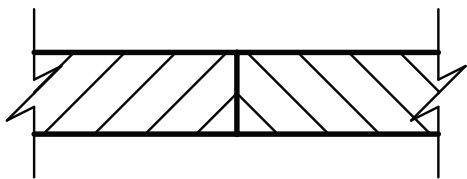
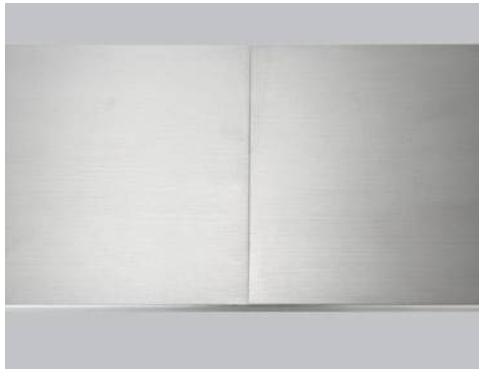

Erhältliche Ausführung / Lavorazione disponibile

SmartSteel Collection



SolidSteel Collection



Erhältliche Oberflächen / Superfici disponibili

Standard

BF WF

Spezial

ID BI BP PL XI XF XB SL WG

Weitere Produktinformationen / Altre informazioni prodotto



**i** Die Stossverbindung ist bauseits gut abzustützen und spaltfrei zusammenzufügen. Positionierung der Nahtstelle nach Vorgaben im freien Winkel oder in der Gehrung möglich.

Il giunto di testa dev'essere supportato in loco e il collegamento va effettuato senza fessure. Possibile posizionamento del punto di giunzione come da specifica, ad angolo aperto o nello smusso.

## Verbindung Crea / Giunzione Crea



### Verbindung Crea / Giunzione Crea

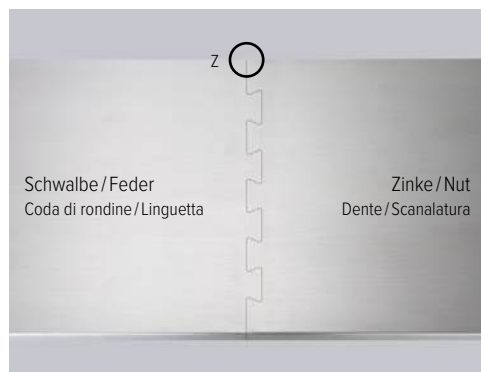

#### Erhältliche Ausführung / Lavorazione disponibile

SmartSteel Collection



SolidSteel Collection



#### Erhältliche Oberflächen / Superfici disponibili

Standard

BF

WF

Spezial

ID

BI

BP

PL

XI

XF

XB

SL

WG

Weitere Produktinformationen / Altre informazioni prodotto



**i** Die Verbindung Crea ist in der Breite von 300–1980 mm erhältlich (siehe max. Breite Seite 24). Die Verzahnung variiert in der Breite. La giunzione Crea è disponibile in larghezze comprese tra 300 e 1980mm (vedi dimensioni max. sulla pagina 24). La dentatura varia in larghezza.

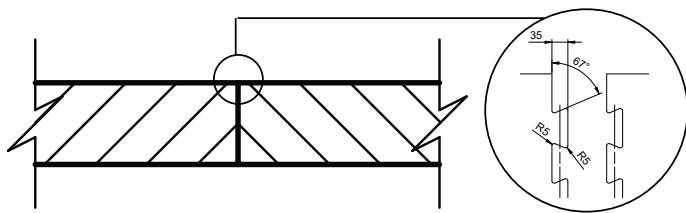

Detail Z: Ausschnitt Crea / Dettaglio Z: intaglio Crea

#### Ein Statement aus Edelstahl

Die Verbindung Crea setzt edle Akzente und verbindet unsere Edelstahl-Massanfertigungen mit Materialien wie Holz, Keramik und Stein als zeitlose Exklusivität. Die präzise, kühle Oberfläche des Edelstahls steht im Kontrast zum Beispiel zur warmen Maserung des Holzes, was den handwerklich-technischen Charakter des Designs betont.

#### Verbindung Crea als Designelement

Die Verbindung Crea wird hier primär als Designelement eingesetzt und dient der visuellen Betonung des Übergangs zwischen unterschiedlichen Materialien wie Edelstahl und Holz, Keramik oder Stein. Durch den Kontrast zwischen den Werkstoffen entsteht eine spannende Verbindung von Tradition und Moderne:

- das handwerkliche Prinzip symbolisiert Präzision und Stabilität,
- während die Materialkombination von Edelstahl und naturnahe Materialien eine ästhetische Spannung zwischen kalt und warm, technisch und natürlich, glatt und strukturiert erzeugt.

#### Un punto di riferimento in materia di acciaio inox

La giunzione Crea dà un tocco di eleganza e coniuga i nostri prodotti su misura in acciaio inox con materiali come legno, ceramica e pietra, dando vita a un'esclusività senza tempo. La superficie precisa e fredda dell'acciaio inox, ad esempio, crea un contrasto con le calde venature del legno, accentuando il carattere artigianale e tecnico del design.

#### L'assemblage Crea come élément de design

La giunzione Crea viene utilizzata qui principalmente come elemento di design e serve a sottolineare visivamente il passaggio tra materiali diversi come acciaio inox e legno, ceramica o pietra. Il contrasto tra i materiali crea un affascinante connubio tra tradizione e modernità:

- il principio artigianale simboleggia precisione e stabilità,
- mentre la combinazione di acciaio inox e materiali affini alla natura crea una carica estetica tra freddo e caldo, tecnico e naturale, liscio e strutturato.

## SolidArt/SolidArt



## SolidArt für den flächenbündigen Einbau in bauseitiger Arbeitsplatte / SolidArt per montaggio a filo top su piano di lavoro predisposto in loco

Arbeitsplatte bauseits z.B. Holz, Stein, etc. / Piano di lavoro predisposto in loco, per es. legno, pietra, ecc.



Schleifrichtung / Direzione di rettifica

Formbeispiel/ Esempio di forma

Schnitt A-A/ Intaglio A-A

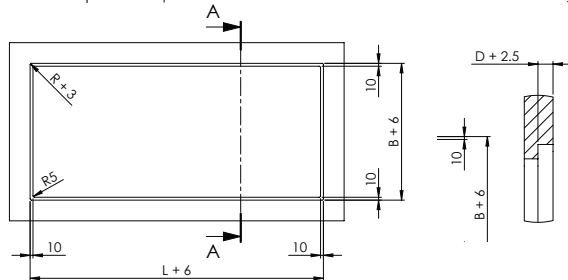

## Erhältliche Ausführung / Lavorazione disponibile

SmartSteel Collection

—

SolidSteel Collection

✓

## Erhältliche Oberflächen / Superfici disponibili

Standard

BF WF

Spezial

ID BI BP PL XI XF XB SL WG

Weitere Produktinformationen / Altre informazioni prodotto



**i** Form, Abmessung sowie Ausstattung nach Vorgabe.  
Forma, dimensioni e dotazione secondo specifica.

### Massgefertigte Module – abgestimmt auf die unterschiedlichen Funktionsbereiche in der Küche

Jedes SolidArt-Modul ist ein echtes Unikat. Das exklusive Produktkonzept für den flächenbündigen Einbau besticht durch seinen enormen Gestaltungsspielraum. Eine Standardisierung gibt es nicht, jedes Modul wird genau auf die individuellen Bedürfnisse der Kunden zugeschnitten. SolidArt fügt sich so optimal ins jeweilige Küchenkonzept ein und deckt alle wichtigen Funktionsbereiche in der Arbeitsebene einer Küche perfekt ab.

### Einzige Rezepte für die individuelle Küchengestaltung

Mit SolidArt sind Ihren ästhetischen und funktionalen Ansprüchen keine Grenzen gesetzt. Die Kombination mit anderen Materialien sorgt für interessante Kontraste. Die SolidArt-Dimensionen sind frei wählbar genauso wie die Form des Moduls.

### Eleganz, die Akzente setzt

Ein neuer Blickfang für edle Küchenkonzepte und anspruchsvolle Kunden. Das modulare Konzept bietet eine breite Auswahl an Funktionen und Anwendungsmöglichkeiten, die individuell ergänzt und kombiniert werden können. Jedes SolidArt-Modul besticht durch eine vollendete Balance von Funktionalität und Ästhetik.

### Moduli creati per armonizzarsi in modo versatile con le varie aree funzionali della cucina

Ogni modulo SolidArt è un vero e proprio pezzo unico, un'esclusiva concezione di prodotto da incastonare a filo top e che affascina per l'incredibile ampiezza creativa che esso offre. Niente è standardizzato, in quanto ogni modulo è realizzato su misura delle esigenze individuali del cliente. Ciò consente a SolidArt di inserirsi armoniosamente in qualsiasi progetto di cucina e di coprire alla perfezione tutte le aree funzionali tipiche dell'attività in cucina.

### Ricette esclusive per la personalizzazione della vostra cucina

Con SolidArt nessun limite viene posto alle vostre esigenze di estetica e funzionalità, mentre la combinabilità con altri materiali è portatrice di interessanti contrasti. Si è liberi di scegliere dimensioni e forma del modulo SolidArt, ma anche tra sei finiture superficiali diverse.

### Nuovi orizzonti di eleganza

Una nuova prospettiva per progetti di cucina raffinati e per clienti esigenti. Questo concetto modulare offre una vasta scelta di funzioni e di applicazioni possibili, tutte integrabili e combinabili reciprocamente. Ogni modulo SolidArt seduce per il suo perfetto equilibrio tra funzionalità ed estetica.

## Positionierung der Erdungsfahne / Posizionamento capocorda di terra

Gültig für Bauteile ab einer Größe von 1m<sup>2</sup>  
Valido per elementi strutturali con dimensioni a partire da 1m<sup>2</sup>

Bauteil Elemento strutturale	Position Erdungsfahne <b>ohne</b> Komponenten Posizione capocorda di terra <b>senza</b> componenti	Position Erdungsfahne <b>mit</b> Komponenten Posizione capocorda di terra <b>con</b> componenti
Arbeitsplatte einteilig Piano di lavoro in più parti	Freie Positionierung <sup>1</sup> Posizionamento libero <sup>1</sup>	1 Erdungsfahne wahlweise beim Becken, beim Kochfeld oder bei der Steckdose 1 capocorda di terra, a scelta presso il lavello, il piano di cottura o la presa
Arbeitsplatte mehrteilig Piano di lavoro in più parti	Freie Positionierung pro Arbeitsplatte <sup>1</sup> Posizionamento libero per ogni piano di lavoro <sup>1</sup>	Pro Arbeitsplatte 1 Erdungsfahne wahlweise beim Becken, beim Kochfeld oder bei der Steckdose Capocorda di terra per ogni piano di lavoro, a scelta presso il lavello, il piano di cottura o la presa
Rückwand Pannello posteriore	Freie Positionierung pro Rückwand <sup>1</sup> Posizionamento libero per ogni pannello posteriore <sup>1</sup>	Pro Rückwand bei der Steckdose (Bei mehreren Steckdosen ist eine Erdungsfahne pro Rückwand ausreichend) Presso la presa per ogni pannello posteriore (nel caso di più prese, è sufficiente un capocorda di terra per ogni pannello)

<sup>1</sup> Ohne Vorgaben wird die Positionierung der Erdungsfahne werkseitig bestimmt. /<sup>1</sup> In assenza di indicazioni, il posizionamento del capocorda di terra viene predefinito in fabbrica.

 Erdungskabel an der gekennzeichneten Position montieren.  
Montare il cavo di terra nella posizione contrassegnata.

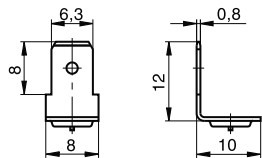

Erdungsfahne / Flachstecker L  
Capocorda di terra / Connettore piatto L

## Allgemeintoleranzen für Längen- und Winkelmasse Tolleranze generali per lunghezze e angoli

Nennmassbereich Gamma di dimensioni nominali	bis 1000 mm fino a 1000 mm	1001 – 2000 mm	2001 – 4000 mm	über 4000 mm oltre 4000 mm
Längenmasse Misure di lunghezza	±1	±2	±3	Tolleranzen bei Bestellung vermerken. Indicare le tolleranze in sede d'ordine.



 Grenzabmasse in mm für Nennmassbereiche.  
Dimensioni limite in mm per gamma di dimensioni nominali.

Nennmassbereich Gamma di dimensioni nominali	über 400 mm oltre 400 mm
Winkelmasse / Misure d'angolo Rundungshalbmesser und Fasen / Raggi di curvatura e smussi	±0° 10'

 Grenzabmasse in mm für Nennmassbereiche.  
Misure limite in mm per campo nominale di misura.



## Sortiment nach Unterschrankmassen / Assortimento per dimensioni di base

	35cm	40cm	45cm	50cm	55cm
<b>Linero</b> sFlow, Typ M sFlow, tipo M	 Linero: LIO 18 	 Linero: LIO 34 	 Linero: LIO 40 	 Linero: LIO 45 	 Linero: LIO 50 
	 Linero: LIO 18 	 Linero: LIO 34 	 Linero: LIO 40 	 Linero: LIO 45 	 Linero: LIO 50 
<b>Daneo</b> sFlow, Typ S sFlow, tipo S	 Daneo: DAN 18 	 Daneo: DAN 34 	 Daneo: DAN 40 	 Daneo: DAN 45 	 Daneo: DAN 50 
	 Daneo: DAN 18 	 Daneo: DAN 34 	 Daneo: DAN 40 	 Daneo: DAN 45 	 Daneo: DAN 50 
<b>Vantis</b> sFlow, Typ M sFlow, tipo M	 Vantis: V 11 	 Vantis: V 34 	 Vantis: V 40 	 Vantis: V 45 	 Vantis: V 50-42 
	 Vantis: V 11 	 Vantis: V 34 	 Vantis: V 40 	 Vantis: V 45 	 Vantis: V 50-42 
		 Vantis: VX 34 Varix 	 Vantis: VX 40 Varix 	 Vantis: VG 45 Green 	 Vantis: VG 50-42 Green 
				 Vantis: VX 45 Varix 	 Vantis: VX 50-42 Varix 
<b>Silver Star</b>	 Silver Star: SIL 9 	 Silver Star: SIL 34 		 Silver Star: SIL 45 	 Silver Star: SIS 50 
	 Silver Star: SIL 18 		 Silver Star: SX 40 Varix 		 Silver Star: SX 50-42 Varix 
<b>Einzel-Becken</b> Lavelli a vasca singola		 Comfort: COM 34 	 Comfort: COM 40 	 Rund: R 44 	

**GREEN LINE** Green Line ist eine eigenständige auf Nachhaltigkeit ausgerichtete Produktausführung.  
Green Line è una versione di prodotto autonoma calibrata sulla sostenibilità.

Auffrisch- und Pflegeservice  
Mehr Infos siehe Seite 25  
Servizio di pulizia e manutenzione  
Per maggiori informazioni, vedere pag. 25

55cm

60cm

80cm



Linero: LIO 18 + LIO 34 



Linero: LIO 55 



Linero: LIO 18 + LIO 34 



Linero: LIO 55 



Daneo: DAN 18 + DAN 34 



Daneo: DAN 55 



Daneo: DAN 18 + DAN 34 



Daneo: DAN 55 



Vantis: V 50-35   
Vantis: V 50-35 + V 11



Vantis: V 50-35   
Vantis: V 50-35 + V 11



Vantis: VG 50-35 Green 



Vantis: V 55 



Vantis: V 55 



Vantis: VG 55 Green 



Vantis: VX 55 Varix 



Silver Star: SIL 50   
Silver Star: SIL 50 + SIL 9



Silver Star: SIL 18 + SIL 34 



Silver Star: SIL 55 



Accento: A 65 



Accento: A 75 

Sortiment nach Unterschrankmassen / Assortimento per dimensioni di base

Massenfertigungen  
Soluzioni a misura

	40cm	45cm	50cm	55cm
<b>Linero</b> sFlow, Typ M sFlow, tipo M			 Starline Pure mit/ con: LIO 45 <sup>100</sup>	
			 Starline Pure mit/ con: LIO 45 <sup>100</sup>	
<b>Daneo</b> sFlow, Typ S sFlow, tipo S			 Daneo DAN 100-45 Ambio mit oder ohne Riffel con o senza scanalatura <sup>106</sup>	 Starline Pure mit/ con: DAN 45 <sup>103</sup>
			 Daneo DAN 100-45 Ambio mit oder ohne Riffel con o senza scanalatura <sup>106</sup>	 Starline Pure mit/ con: DAN 45 <sup>103</sup>
			 Daneo DAN 100-50 Ambio mit oder ohne Riffel con o senza scanalatura <sup>107</sup>	
			 Daneo DAN 100-50 Ambio mit oder ohne Riffel con o senza scanalatura <sup>107</sup>	
<b>Vantis</b> sFlow, Typ M sFlow, tipo M	 Vantis: V 100-40 Classic mit oder ohne Riffel con o senza scanalatura <sup>110</sup>	 Vantis: V 90-45 Classic mit oder ohne Riffel con o senza scanalatura <sup>109</sup>	 Vantis: V 100-45 Classic mit oder ohne Riffel con o senza scanalatura <sup>111</sup>	 Vantis: V 100-50 Classic mit oder ohne Riffel con o senza scanalatura <sup>112</sup>
	 Vantis: V 100-40 Classic mit oder ohne Riffel con o senza scanalatura <sup>110</sup>	 Vantis: V 90-45 Classic mit oder ohne Riffel con o senza scanalatura <sup>109</sup>	 Vantis: V 100-45 Classic mit oder ohne Riffel con o senza scanalatura <sup>111</sup>	 Vantis: V 100-50 Classic mit oder ohne Riffel con o senza scanalatura <sup>112</sup>
		 Vantis: VG 90-45 Green Classic mit oder ohne Riffel con o senza scanalatura <sup>114</sup>	 Vantis: VG 100-45 Green Classic mit oder ohne Riffel con o senza scanalatura <sup>114</sup>	 Vantis: VG 100-50 Green Classic mit oder ohne Riffel con o senza scanalatura <sup>115</sup>
		 Vantis: VX 90-45 Varix Classic mit oder ohne Riffel con o senza scanalatura <sup>116</sup>	 Vantis: VX 100-45 Varix Classic mit oder ohne Riffel con o senza scanalatura <sup>117</sup>	 Vantis: VX 100-50 Varix Classic mit oder ohne Riffel con o senza scanalatura <sup>118</sup>
			 Silver Star: SIL 90-45 Classic mit oder ohne Riffel con o senza scanalatura <sup>119</sup>	 Silver Star: SIL 100-45 Classic mit oder ohne Riffel con o senza scanalatura <sup>120</sup>
			 Silver Star: SIS 100-50 Classic mit oder ohne Riffel con o senza scanalatura <sup>120</sup>	
<b>Silver Star</b>	 Silver Star: SX 100-40 Varix Classic mit oder ohne Riffel con o senza scanalatura <sup>122</sup>			 Silver Star: SX 100-50 Varix Classic mit oder ohne Riffel con o senza scanalatura <sup>122</sup>
<b>Comfort</b>	 Comfort: COM 75 <sup>123</sup> Comfort: COM 90	 Comfort: COM 100-40 mit oder ohne Riffel con o senza scanalatura <sup>123</sup>		



Green Line ist eine eigenständige auf Nachhaltigkeit ausgerichtete Produktausführung.  
Green Line è una versione di prodotto autonoma calibrata sulla sostenibilità.

Auffrisch- und Pflegeservice  
Mehr Infos siehe Seite 25  
Servizio di pulizia e manutenzione  
Per maggiori informazioni, vedere pag. 25

55cm



Starline Pure mit/con: LIO 50 



Starline Pure mit/con: LIO 50 



Starline Pure mit/con: DAN 50 



Starline Pure mit/con: DAN 50 

60cm



Starline Pure mit/con: LIO 55 



Starline Pure mit/con: LIO 55 



Daneo DAN 100-55 Ambio mit oder ohne Riffel con o senza scanalatura 



Daneo DAN 100-55 Ambio mit oder ohne Riffel con o senza scanalatura 



Starline Pure mit/con: DAN 55 



Starline Pure mit/con: DAN 55 



Vantis: V 100-55 Classic mit oder ohne Riffel con o senza scanalatura 



Vantis: V 100-55 Classic mit oder ohne Riffel con o senza scanalatura 



Vantis: VG 100-55 Green Classic mit oder ohne Riffel con o senza scanalatura 

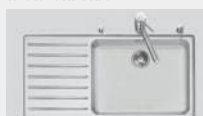

Vantis: VX 100-55 Varix Classic mit oder ohne Riffel con o senza scanalatura 



Silver Star: SIL 100-55 Classic mit oder ohne Riffel con o senza scanalatura 



Silver Star: SIL 100-18/34 Classic mit oder ohne Riffel con o senza scanalatura 

80cm

90cm





Comfort: COM 135-34 







Comfort: COM 135-40 

## Linero

Küchenzubehör für Linero siehe / Accessori per cucina per Linero v. 

 Schwenkbare Überlaufkappe  
Placchetta di troppopieno a ribalta

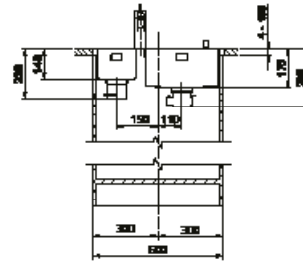
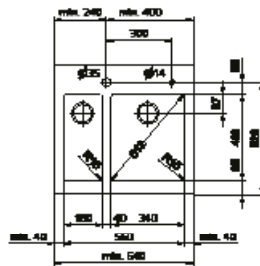

 Für Decor Oberfläche, BX und XF auf Anfrage.  
Su richiesta, per superfici Decor, BX e XF.

Modell Modello	Material Materiale	Ventil sFlow, Typ M Piletta sFlow, tipo M	 Advant	 in / in cm
LIO 18	Edelstahl, matt Acciaio inox, opaco	3 1/2" Tipo	–	◀35▶
LIO 34	Edelstahl, matt Acciaio inox, opaco	3 1/2" TouchFlow	–	◀40▶
		3 1/2" Druckknopf / Pulsante 	–	
		3 1/2" Raumspar / Salvaspazio	✓	
LIO 18 + LIO 34	Edelstahl, matt Acciaio inox, opaco	3 1/2" Tipo	–	◀60▶
		3 1/2" Tipo + TouchFlow	–	
		3 1/2" Tipo + Druckknopf Tipo + Pulsante 	–	
		3 1/2" Tipo + Raumspar Tipo + Salvaspazio	✓	
		3 1/2" Tipo + Tipo	–	



 Für Decor Oberfläche, BX und XF auf Anfrage.  
Su richiesta, per superfici Decor, BX e XF.

\* Kombination LIO 18 + LIO 34 mit eFlow Desino oder TouchFlow Desino:  
Erfordert beidseitigen Ausschnitt der Korpuswand, bei LIO 18 mit vergrößertem Ausschnitt.  
Combinazione LIO 18 + LIO 34 con eFlow Desino o TouchFlow Desino:  
Richiede un intaglio della parete dell'armadio su entrambi i lati, per LIO 18 un intaglio allargato.

Modell Modello	Material Materiale	Ventil sFlow, Typ M Piletta sFlow, tipo M	 Advant	 in / in cm
LIO 18*	Edelstahl, matt Acciaio inox, opaco	3 1/2" eFlow Desino	–	◀35▶
		3 1/2" TouchFlow Desino	–	
		3 1/2" Tipo Desino	–	
LIO 34	Edelstahl, matt Acciaio inox, opaco	3 1/2" eFlow Desino	–	◀40▶
		3 1/2" TouchFlow Desino	–	
		3 1/2" Raumspar Desino / Salvaspazio Desino	✓	
LIO 18 + LIO 34	Edelstahl, matt Acciaio inox, opaco	3 1/2" Tipo Desino	–	◀60▶
		3 1/2" Tipo Desino + TouchFlow Desino	–	
		3 1/2" Tipo Desino + Raumspar Desino Tipo Desino + Salvaspazio Desino	✓	
		3 1/2" Tipo Desino + Tipo Desino	–	

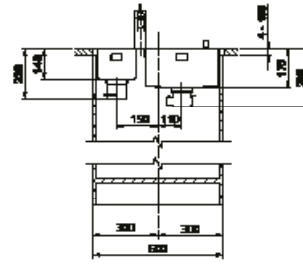
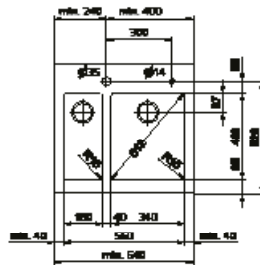

 eFlow mit eControl  
eFlow con eControl

 13

 Schwenkbare Überlaufkappe  
Placchetta di troppopieno a ribalta

 13

 Desino: Verdeckter Ablauf mit untenliegendem Korb  
Desino: Scarico coperto con griglietta inferiore

 12



Für eFlow Desino  
Per eFlow Desino

Für TouchFlow Desino, Raumspar Desino und Tipo Desino  
Per TouchFlow Desino, Salvaspazio Desino e Tipo Desino



Für eFlow Desino, TouchFlow Desino, Raumspar Desino und Tipo Desino  
Per eFlow Desino, TouchFlow Desino, Salvaspazio Desino e Tipo Desino

**Linero**

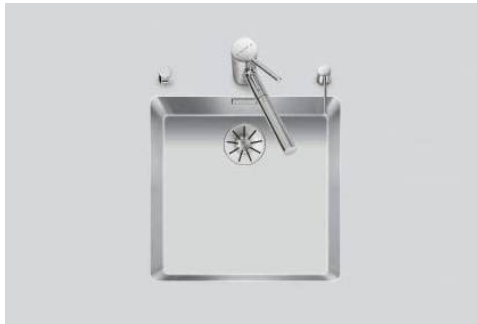

Küchenzubehör für Linero siehe / Accessori per cucina per Linero v. 



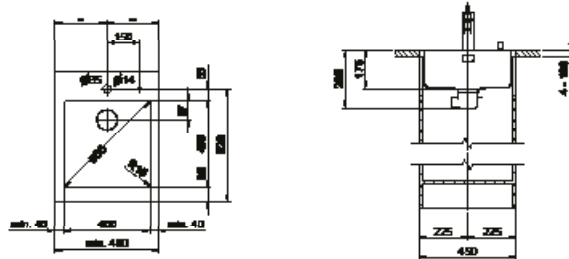

 Schwenkbare Überlaufkappe  
Placchetta di troppopieno a ribalta

Modell Modello	Material Materiale	Ventil sFlow, Typ M Piletta sFlow, tipo M	 Advant	 in / in cm
<b>LIO 40</b>	Edelstahl, matt Acciaio inox, opaco	3 1/2" TouchFlow	–	◀45▶
		3 1/2" Druckknopf / Pulsante <span style="background-color: #0070C0; color: white; padding: 2px;">new</span>	–	
		3 1/2" Raumspar / Salvaspazio	✓	
		3 1/2" Tipo	–	

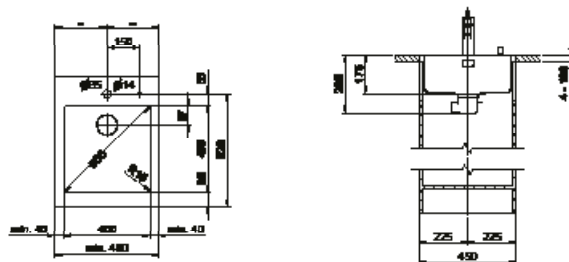

Modell Modello	Material Materiale	Ventil sFlow, Typ M Piletta sFlow, tipo M	 Advant	 in / in cm
<b>LIO 40</b>	Edelstahl, matt Acciaio inox, opaco	3 1/2" eFlow Desino	–	◀45▶
		3 1/2" TouchFlow Desino	–	
		3 1/2" Raumspar Desino / Salvaspazio Desino	✓	
		3 1/2" Tipo Desino	–	



 eFlow mit eControl  
eFlow con eControl

 13

 Schwenkbare Überlaufkappe  
Placchetta di troppopieno a ribalta

 13

 Desino: Verdeckter Ablauf mit untenliegendem Korb  
Desino: Scarico coperto con griglietta inferiore

 12



Für eFlow Desino  
Per eFlow Desino

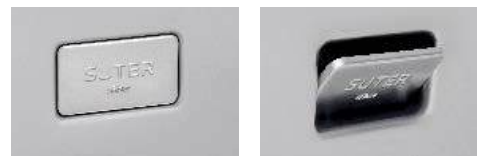



Für TouchFlow Desino, Raumspar Desino und Tipo Desino  
Per TouchFlow Desino, Salvaspazio Desino e Tipo Desino



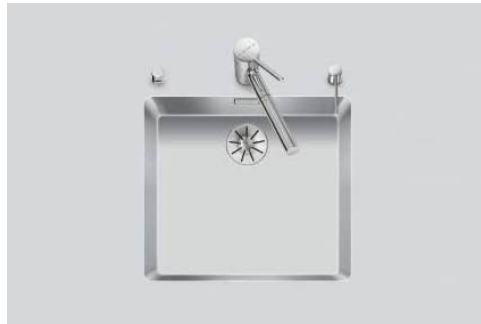

Für eFlow Desino, TouchFlow Desino, Raumspar Desino und Tipo Desino  
Per eFlow Desino, TouchFlow Desino, Salvaspazio Desino e Tipo Desino



## Linero

Küchenzubehör für Linero siehe / Accessori per cucina per Linero v. 

 Schwenkbare Überlaufkappe  
Placchetta di troppopieno a ribalta

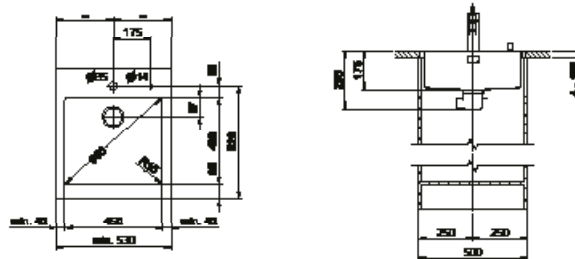
Modell Modello	Material Materiale	Ventil sFlow, Typ M Piletta sFlow, tipo M	 Advant	 in / in cm
LIO 45	Edelstahl, matt Acciaio inox, opaco	3 1/2" TouchFlow	–	◀50▶
		3 1/2" Druckknopf / Pulsante <span style="background-color: #0070C0; color: white; padding: 2px;">new</span>	–	
		3 1/2" Raumspar / Salvaspazio	✓	
		3 1/2" Tipo	–	



Modell Modello	Material Materiale	Ventil sFlow, Typ M Piletta sFlow, tipo M	 Advant	 in / in cm
LIO 45	Edelstahl, matt Acciaio inox, opaco	3 1/2" eFlow Desino	–	◀50▶
		3 1/2" TouchFlow Desino	–	
		3 1/2" Raumspar Desino / Salvaspazio Desino	✓	
		3 1/2" Tipo Desino	–	

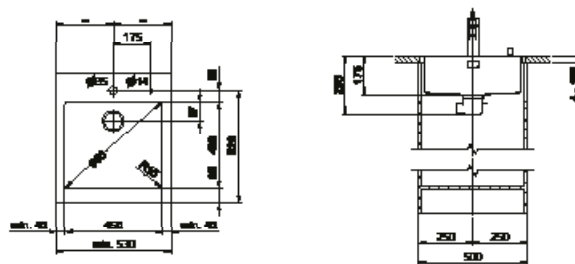

 eFlow mit eControl  
eFlow con eControl

13

 Schwenkbare Überlaufkappe  
Placchetta di troppopieno a ribalta

13

 Desino: Verdeckter Ablauf mit untenliegendem Korb  
Desino: Scarico coperto con griglietta inferiore

12



Für eFlow Desino  
Per eFlow Desino

Für TouchFlow Desino, Raumspar Desino und Tipo Desino  
Per TouchFlow Desino, Salvaspazio Desino e Tipo Desino



Für eFlow Desino, TouchFlow Desino, Raumspar Desino und Tipo Desino  
Per eFlow Desino, TouchFlow Desino, Salvaspazio Desino e Tipo Desino

**Linero**

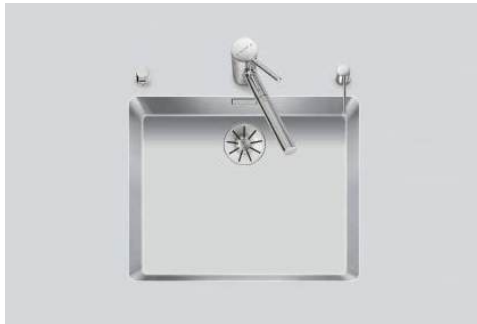

Küchenzubehör für Linero siehe / Accessori per cucina per Linero v. 



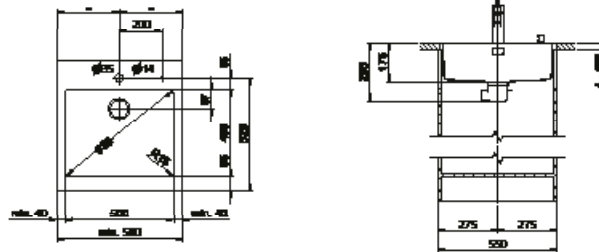

 Schwenkbare Überlaufkappe  
Placchetta di troppopieno a ribalta

Modell Modello	Material Materiale	Ventil sFlow, Typ M Piletta sFlow, tipo M	 Advant	 in / in cm
LIO 50	Edelstahl, matt Acciaio inox, opaco	3 1/2" TouchFlow	–	◀55▶
		3 1/2" Druckknopf / Pulsante <span style="background-color: #0070C0; color: white; padding: 2px;">new</span>	–	
		3 1/2" Raumspar / Salvaspazio	✓	
		3 1/2" Tipo	–	

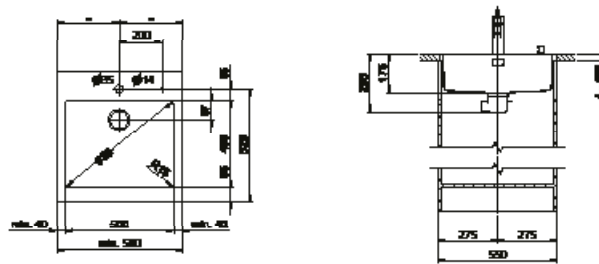

Modell Modello	Material Materiale	Ventil sFlow, Typ M Piletta sFlow, tipo M	 Advant	 in / in cm
LIO 50	Edelstahl, matt Acciaio inox, opaco	3 1/2" eFlow Desino	–	◀55▶
		3 1/2" TouchFlow Desino	–	
		3 1/2" Raumspar Desino / Salvaspazio Desino	✓	
		3 1/2" Tipo Desino	–	



 eFlow mit eControl  
eFlow con eControl

 13

 Schwenkbare Überlaufkappe  
Placchetta di troppopieno a ribalta

 13

 Desino: Verdeckter Ablauf mit untenliegendem Korb  
Desino: Scarico coperto con griglietta inferiore

 12



Für eFlow Desino  
Per eFlow Desino

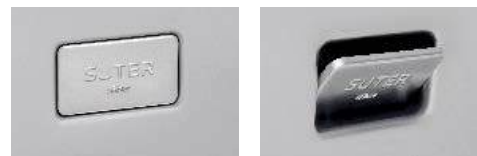

Für TouchFlow Desino, Raumspar Desino und Tipo Desino  
Per TouchFlow Desino, Salvaspazio Desino e Tipo Desino





Für eFlow Desino, TouchFlow Desino, Raumspar Desino und Tipo Desino  
Per eFlow Desino, TouchFlow Desino, Salvaspazio Desino e Tipo Desino



## Linero

Küchenzubehör für Linero siehe / Accessori per cucina per Linero v. 

 Schwenkbare Überlaufkappe  
Placchetta di troppopieno a ribalta

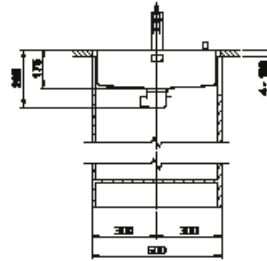
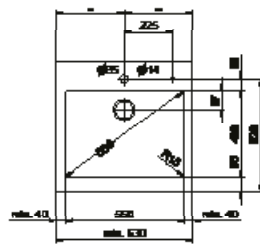
Modell Modello	Material Materiale	Ventil sFlow, Typ M Piletta sFlow, tipo M	 Advant	 in / in cm
LIO 55	Edelstahl, matt Acciaio inox, opaco	3 1/2" TouchFlow	–	◀60▶
		3 1/2" Druckknopf / Pulsante <span style="color: blue; font-weight: bold;">new</span>	–	
		3 1/2" Raumspar / Salvaspazio	✓	
		3 1/2" Tipo	–	



Modell Modello	Material Materiale	Ventil sFlow, Typ M Piletta sFlow, tipo M	 Advant	 in / in cm
LIO 55	Edelstahl, matt Acciaio inox, opaco	3 1/2" eFlow Desino	–	◀60▶
		3 1/2" TouchFlow Desino	–	
		3 1/2" Raumspar Desino / Salvaspazio Desino	✓	
		3 1/2" Tipo Desino	–	

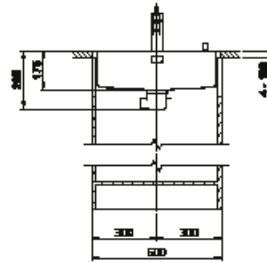
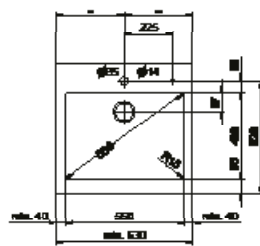

 eFlow mit eControl  
eFlow con eControl

13

 Schwenkbare Überlaufkappe  
Placchetta di troppopieno a ribalta

13

 Desino: Verdeckter Ablauf mit untenliegendem Korb  
Desino: Scarico coperto con griglietta inferiore

12



Für eFlow Desino  
Per eFlow Desino



Für TouchFlow Desino, Raumspar Desino und Tipo Desino  
Per TouchFlow Desino, Salvaspazio Desino e Tipo Desino



Für eFlow Desino, TouchFlow Desino, Raumspar Desino und Tipo Desino  
Per eFlow Desino, TouchFlow Desino, Salvaspazio Desino e Tipo Desino





Daneo

Küchenzubehör für Daneo siehe / Accessori per cucina per Daneo v. 



 Schwenkbare Überlaufkappe  
Placchetta di troppopieno a ribalta

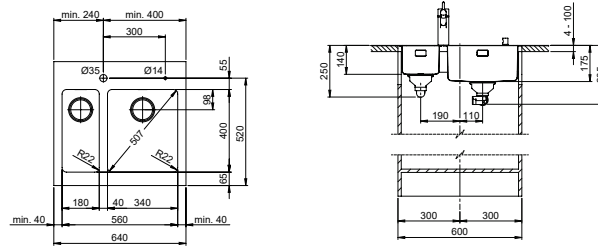

 Für Decor Oberfläche, BX und XF auf Anfrage.  
Su richiesta, per superfici Decor, BX e XF.

Modell Modello	Material Materiale	Ventil sFlow, Typ S Piletta sFlow, tipo S	 Advant	 in / in cm
<b>DAN 18</b>	Edelstahl, matt Acciaio inox, opaco	3 1/2" Tipo	–	◀35▶
<b>DAN 34</b>	Edelstahl, matt Acciaio inox, opaco	3 1/2" TouchFlow	–	◀40▶
		3 1/2" Raumspar / Salvaspazio 3 1/2" Tipo	✓	
<b>DAN 18 + DAN 34</b>	Edelstahl, matt Acciaio inox, opaco	3 1/2" Tipo + TouchFlow	–	◀60▶
		3 1/2" Tipo + Raumspar / Tipo + Salvaspazio	✓	
		3 1/2" Tipo + Tipo	–	



 Für Decor Oberfläche, BX und XF auf Anfrage.  
Su richiesta, per superfici Decor, BX e XF.

\* Kombination DAN 18 + DAN 34 mit eFlow Desino oder TouchFlow Desino:  
Erfordert beidseitigen Ausschnitt der Korpuswand, bei DAN 18 mit vergrössertem Ausschnitt.  
Combinazione DAN 18 + DAN 34 con eFlow Desino o TouchFlow Desino:  
Richiede un intaglio della parete dell'armadio su entrambi i lati, per DAN 18 un intaglio allargato.

Modell Modello	Material Materiale	Ventil sFlow, Typ M Piletta sFlow, tipo M	 Advant	 in / in cm
<b>DAN 18*</b>	Edelstahl, matt Acciaio inox, opaco	3 1/2" eFlow Desino	–	◀35▶
		3 1/2" TouchFlow Desino	–	
		3 1/2" Tipo Desino	–	
<b>DAN 34</b>	Edelstahl, matt Acciaio inox, opaco	3 1/2" eFlow Desino	–	◀40▶
		3 1/2" TouchFlow Desino	–	
		3 1/2" Raumspar Desino / Salvaspazio Desino 3 1/2" Tipo Desino	✓	
<b>DAN 18 + DAN 34</b>	Edelstahl, matt Acciaio inox, opaco	3 1/2" Tipo Desino + TouchFlow Desino	–	◀60▶
		3 1/2" Tipo Desino + Raumspar Desino 3 1/2" Tipo Desino + Salvaspazio Desino	✓	
		3 1/2" Tipo Desino + Tipo Desino	–	

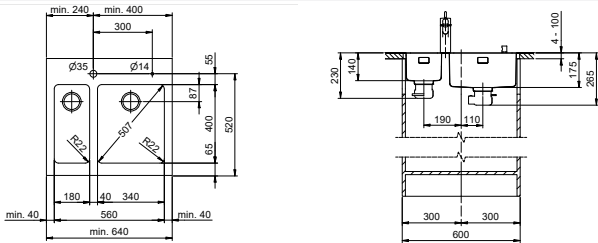

 eFlow mit eControl  
eFlow con eControl



 Schwenkbare Überlaufkappe  
Placchetta di troppopieno a ribalta



 Desino: Verdeckter Ablauf mit untenliegendem Korb  
Desino: Scarico coperto con griglietta inferiore 





Für eFlow Desino  
Per eFlow Desino



Für TouchFlow Desino, Raumspar Desino und Tipo Desino  
Per TouchFlow Desino, Salvaspazio Desino e Tipo Desino

Für eFlow Desino, TouchFlow Desino, Raumspar Desino und Tipo Desino  
Per eFlow Desino, TouchFlow Desino, Salvaspazio Desino e Tipo Desino



## Daneo

Küchenzubehör für Daneo siehe / Accessori per cucina per Daneo v.  312-314

 Schwenkbare Überlaufkappe  
Placchetta di troppopieno a ribalta

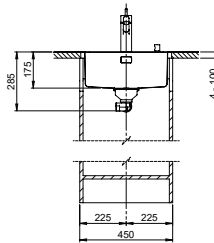
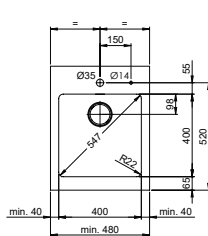
Modell Modello	Material Materiale	Ventil sFlow, Typ S Piletta sFlow, tipo S	 Advant	 in / in cm
DAN 40	Edelstahl, matt Acciaio inox, opaco	3 1/2" TouchFlow	–	◀45▶
		3 1/2" Raumspar / Salvaspazio	✓	
		3 1/2" Tipo	–	



Modell Modello	Material Materiale	Ventil sFlow, Typ M Piletta sFlow, tipo M	 Advant	 in / in cm
DAN 40	Edelstahl, matt Acciaio inox, opaco	3 1/2" eFlow Desino	–	◀45▶
		3 1/2" TouchFlow Desino	–	
		3 1/2" Raumspar Desino / Salvaspazio Desino	✓	
		3 1/2" Tipo Desino	–	

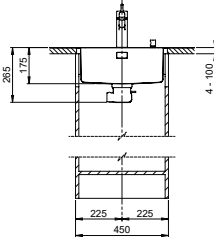
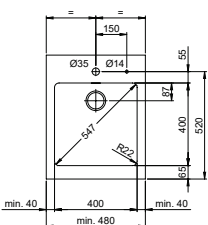

 eFlow mit eControl  
eFlow con eControl

13

 Schwenkbare Überlaufkappe  
Placchetta di troppopieno a ribalta

13

 Desino: Verdeckter Ablauf mit untenliegendem Korb  
Desino: Scarico coperto con griglietta inferiore

12



Für eFlow Desino  
Per eFlow Desino



Für TouchFlow Desino, Raumspar Desino und Tipo Desino  
Per TouchFlow Desino, Salvaspazio Desino e Tipo Desino



Für eFlow Desino, TouchFlow Desino, Raumspar Desino und Tipo Desino  
Per eFlow Desino, TouchFlow Desino, Salvaspazio Desino e Tipo Desino





Daneo



Küchenzubehör für Daneo siehe / Accessori per cucina per Daneo v. 



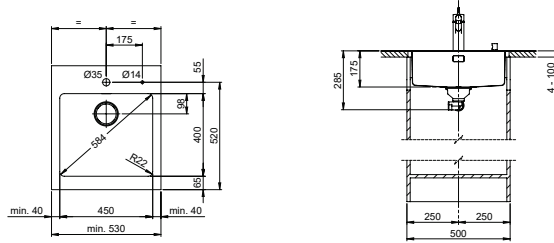

 Schwenkbare Überlaufkappe  
Placchetta di troppopieno a ribalta

Modell Modello	Material Materiale	Ventil sFlow, Typ S Piletta sFlow, tipo S	 Advant	 in / in cm
DAN 45	Edelstahl, matt Acciaio inox, opaco	3 1/2" TouchFlow	–	◀50▶
		3 1/2" Raumspar / Salvaspazio	✓	
		3 1/2" Tipo	–	

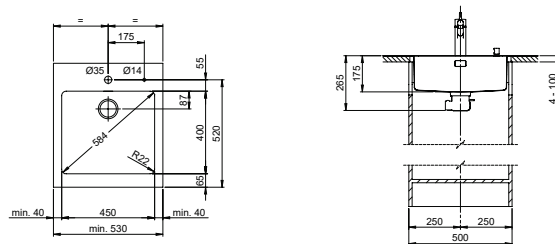

Modell Modello	Material Materiale	Ventil sFlow, Typ M Piletta sFlow, tipo M	 Advant	 in / in cm
DAN 45	Edelstahl, matt Acciaio inox, opaco	3 1/2" eFlow Desino	–	◀50▶
		3 1/2" TouchFlow Desino	–	
		3 1/2" Raumspar Desino / Salvaspazio Desino	✓	
		3 1/2" Tipo Desino	–	



 eFlow mit eControl  
eFlow con eControl



 Schwenkbare Überlaufkappe  
Placchetta di troppopieno a ribalta



 Desino: Verdeckter Ablauf mit untenliegendem Korb  
Desino: Scarico coperto con griglietta inferiore



Für eFlow Desino  
Per eFlow Desino



Für TouchFlow Desino, Raumspar Desino und Tipo Desino  
Per TouchFlow Desino, Salvaspazio Desino e Tipo Desino





Für eFlow Desino, TouchFlow Desino, Raumspar Desino und Tipo Desino  
Per eFlow Desino, TouchFlow Desino, Salvaspazio Desino e Tipo Desino





## Daneo

Küchenzubehör für Daneo siehe / Accessori per cucina per Daneo v. 

 Schwenkbare Überlaufkappe  
Placchetta di troppopieno a ribalta

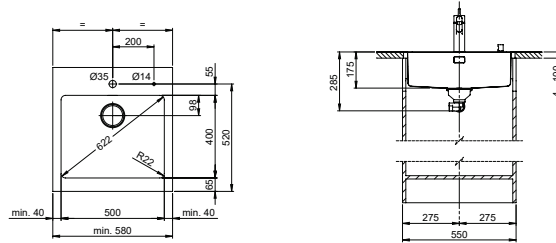
Modell Modello	Material Materiale	Ventil sFlow, Typ S Piletta sFlow, tipo S	 Advant	 in / in cm
DAN 50	Edelstahl, matt Acciaio inox, opaco	3 1/2" TouchFlow	–	◀55▶
		3 1/2" Raumspar / Salvaspazio	✓	
		3 1/2" Tipo	–	



Modell Modello	Material Materiale	Ventil sFlow, Typ M Piletta sFlow, tipo M	 Advant	 in / in cm
DAN 50	Edelstahl, matt Acciaio inox, opaco	3 1/2" eFlow Desino	–	◀55▶
		3 1/2" TouchFlow Desino	–	
		3 1/2" Raumspar Desino / Salvaspazio Desino	✓	
		3 1/2" Tipo Desino	–	

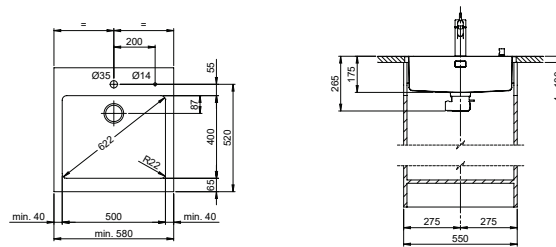

 eFlow mit eControl  
eFlow con eControl



Für eFlow Desino  
Per eFlow Desino



 Schwenkbare Überlaufkappe  
Placchetta di troppopieno a ribalta



Für TouchFlow Desino, Raumspar Desino und Tipo Desino  
Per TouchFlow Desino, Salvaspazio Desino e Tipo Desino



 Desino: Verdeckter Ablauf mit untenliegendem Korb  
Desino: Scarico coperto con griglietta inferiore



Für eFlow Desino, TouchFlow Desino, Raumspar Desino und Tipo Desino  
Per eFlow Desino, TouchFlow Desino, Salvaspazio Desino e Tipo Desino



Daneo

Küchenzubehör für Daneo siehe / Accessori per cucina per Daneo v. 312-314



Schwenkbare Überlaufkappe  
Placchetta di troppopieno a ribalta

Modell Modello	Material Materiale	Ventil sFlow, Typ S Piletta sFlow, tipo S	Advant	in / in cm
DAN 55	Edelstahl, matt Acciaio inox, opaco	3 1/2" TouchFlow	–	◀60▶
		3 1/2" Raumspar / Salvaspazio	✓	
		3 1/2" Tipo	–	

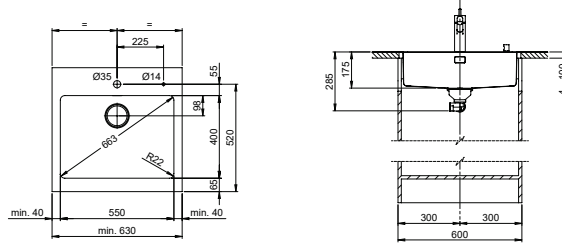

Massanfertigungen  
Soluzioni a misura



Modell Modello	Material Materiale	Ventil sFlow, Typ M Piletta sFlow, tipo M	Advant	in / in cm
DAN 55	Edelstahl, matt Acciaio inox, opaco	3 1/2" eFlow Desino	–	◀60▶
		3 1/2" TouchFlow Desino	–	
		3 1/2" Raumspar Desino / Salvaspazio Desino	✓	
		3 1/2" Tipo Desino	–	

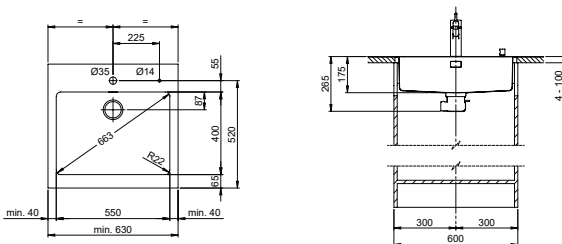

eFlow mit eControl  
eFlow con eControl



Schwenkbare Überlaufkappe  
Placchetta di troppopieno a ribalta



Desino: Verdeckter Ablauf mit untenliegendem Korb  
Desino: Scarico coperto con griglietta inferiore



Für eFlow Desino  
Per eFlow Desino



Für TouchFlow Desino, Raumspar Desino und Tipo Desino  
Per TouchFlow Desino, Salvaspazio Desino e Tipo Desino





Für eFlow Desino, TouchFlow Desino, Raumspar Desino und Tipo Desino  
Per eFlow Desino, TouchFlow Desino, Salvaspazio Desino e Tipo Desino





## Vantis

Küchenzubehör für Vantis siehe / Accessori per cucina per Vantis v. 

 Schwenkbare Überlaufkappe  
Placchetta di troppopieno a ribalta

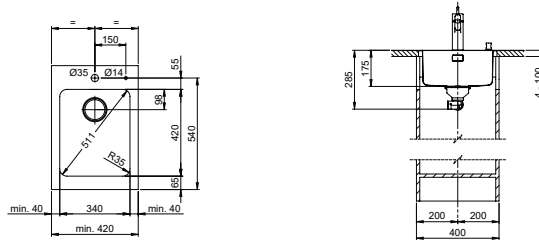
Modell Modello	Material Materiale	Ventil sFlow, Typ S Piletta sFlow, tipo S	 Prime	 in / in cm
V 34	Edelstahl, matt Acciaio inox, opaco	3 1/2" TouchFlow	–	◀40▶
		3 1/2" Raumspar / Salvaspazio	✓	
		3 1/2" Tipo	–	



Modell Modello	Material Materiale	Ventil sFlow, Typ M Piletta sFlow, tipo M	 Advant	 in / in cm
V 34	Edelstahl, matt Acciaio inox, opaco	3 1/2" eFlow Desino	–	◀40▶
		3 1/2" TouchFlow Desino	–	
		3 1/2" Raumspar Desino / Salvaspazio Desino	✓	
		3 1/2" Tipo Desino	–	

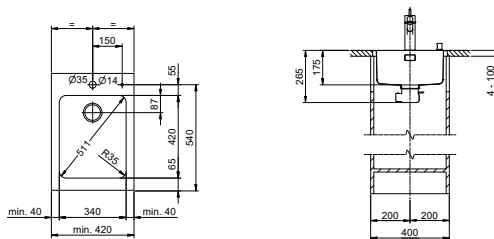

 eFlow mit eControl  
eFlow con eControl

 13

 Schwenkbare Überlaufkappe  
Placchetta di troppopieno a ribalta

 13

 Desino: Verdeckter Ablauf mit untenliegendem Korb  
Desino: Scarico coperto con griglietta inferiore

 12



Für eFlow Desino  
Per eFlow Desino

Für TouchFlow Desino, Raumspar Desino und Tipo Desino  
Per TouchFlow Desino, Salvaspazio Desino e Tipo Desino



Für eFlow Desino, TouchFlow Desino, Raumspar Desino und Tipo Desino  
Per eFlow Desino, TouchFlow Desino, Salvaspazio Desino e Tipo Desino

Vantis



Küchenzubehör für Vantis siehe / Accessori per cucina per Vantis v. 



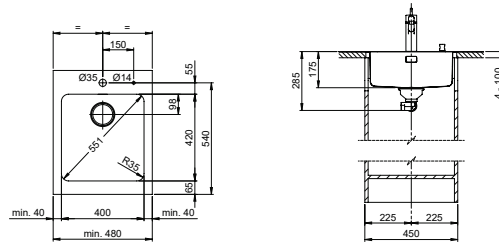

 Schwenkbare Überlaufkappe  
Placchetta di troppopieno a ribalta

Modell Modello	Material Materiale	Ventil sFlow, Typ S Piletta sFlow, tipo S	 Prime	 in / in cm
V 40	Edelstahl, matt Acciaio inox, opaco	3 1/2" TouchFlow	–	◀45▶
		3 1/2" Raumspar / Salvaspazio	✓	
		3 1/2" Tipo	–	

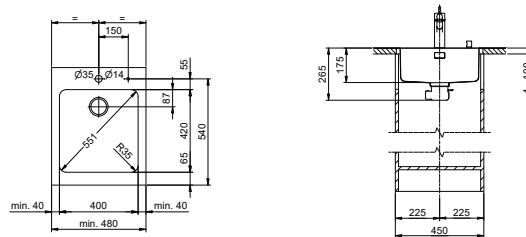

Modell Modello	Material Materiale	Ventil sFlow, Typ M Piletta sFlow, tipo M	 Advant	 in / in cm
V 40	Edelstahl, matt Acciaio inox, opaco	3 1/2" eFlow Desino	–	◀45▶
		3 1/2" TouchFlow Desino	–	
		3 1/2" Raumspar Desino / Salvaspazio Desino	✓	
		3 1/2" Tipo Desino	–	



 eFlow mit eControl  
eFlow con eControl



 Schwenkbare Überlaufkappe  
Placchetta di troppopieno a ribalta



 Desino: Verdeckter Ablauf mit untenliegendem Korb  
Desino: Scarico coperto con griglietta inferiore



Für eFlow Desino  
Per eFlow Desino



Für TouchFlow Desino, Raumspar Desino und Tipo Desino  
Per TouchFlow Desino, Salvaspazio Desino e Tipo Desino





Für eFlow Desino, TouchFlow Desino, Raumspar Desino und Tipo Desino  
Per eFlow Desino, TouchFlow Desino, Salvaspazio Desino e Tipo Desino





## Vantis

Küchenzubehör für Vantis siehe / Accessori per cucina per Vantis v. 

 Schwenkbare Überlaufkappe  
Placchetta di troppopieno a ribalta

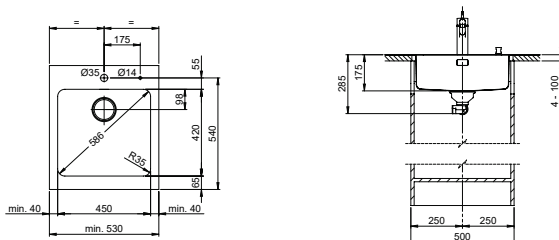
Modell Modello	Material Materiale	Ventil sFlow, Typ S Piletta sFlow, tipo S	 Prime	 in/in cm
V 45	Edelstahl, matt Acciaio inox, opaco	3 1/2" TouchFlow	–	◀50▶
		3 1/2" Raumspar / Salvaspazio	✓	
		3 1/2" Tipo	–	



Modell Modello	Material Materiale	Ventil sFlow, Typ M Piletta sFlow, tipo M	 Advant	 in/in cm
V 45	Edelstahl, matt Acciaio inox, opaco	3 1/2" eFlow Desino	–	◀50▶
		3 1/2" TouchFlow Desino	–	
		3 1/2" Raumspar Desino / Salvaspazio Desino	✓	
		3 1/2" Tipo Desino	–	

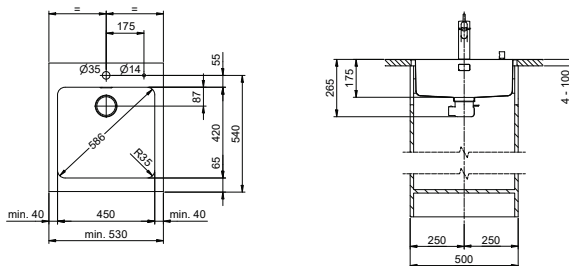

 eFlow mit eControl  
eFlow con eControl



 Schwenkbare Überlaufkappe  
Placchetta di troppopieno a ribalta



 Desino: Verdeckter Ablauf mit untenliegendem Korb  
Desino: Scarico coperto con griglietta inferiore



Für eFlow Desino  
Per eFlow Desino



Für TouchFlow Desino, Raumspar Desino und Tipo Desino  
Per TouchFlow Desino, Salvaspazio Desino e Tipo Desino



Für eFlow Desino, TouchFlow Desino, Raumspar Desino und Tipo Desino  
Per eFlow Desino, TouchFlow Desino, Salvaspazio Desino e Tipo Desino





Vantis

Küchenzubehör für Vantis siehe / Accessori per cucina per Vantis v. 



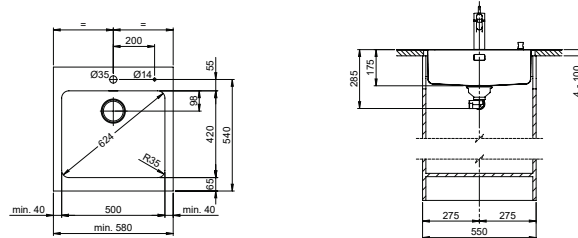

 Schwenkbare Überlaufkappe  
Placchetta di troppopieno a ribalta

Modell Modello	Material Materiale	Ventil sFlow, Typ S Piletta sFlow, tipo S	 Prime	 in / in cm
V 50-42	Edelstahl, matt Acciaio inox, opaco	3 1/2" TouchFlow	–	◀55▶
		3 1/2" Raumspar / Salvaspazio	✓	
		3 1/2" Tipo	–	



Massanfertigungen  
Soluzioni a misura



Modell Modello	Material Materiale	Ventil sFlow, Typ M Piletta sFlow, tipo M	 Advant	 in / in cm
V 50-42	Edelstahl, matt Acciaio inox, opaco	3 1/2" eFlow Desino	–	◀55▶
		3 1/2" TouchFlow Desino	–	
		3 1/2" Raumspar Desino / Salvaspazio Desino	✓	
		3 1/2" Tipo Desino	–	

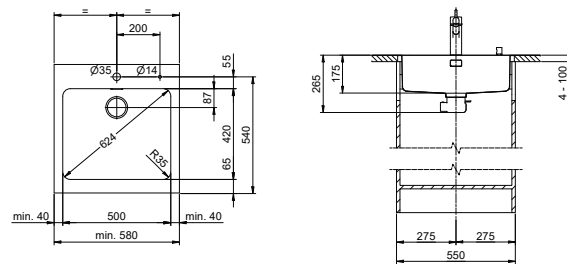

 eFlow mit eControl  
eFlow con eControl

 13

 Schwenkbare Überlaufkappe  
Placchetta di troppopieno a ribalta

 13

 Desino: Verdeckter Ablauf mit untenliegendem Korb  
Desino: Scarico coperto con griglietta inferiore

 12



Für eFlow Desino  
Per eFlow Desino





Für TouchFlow Desino, Raumspar Desino und Tipo Desino  
Per TouchFlow Desino, Salvaspazio Desino e Tipo Desino





Für eFlow Desino, TouchFlow Desino, Raumspar Desino und Tipo Desino  
Per eFlow Desino, TouchFlow Desino, Salvaspazio Desino e Tipo Desino

## Vantis

Küchenzubehör für Vantis siehe / Accessori per cucina per Vantis v. 



 Schwenkbare Überlaufkappe  
Placchetta di troppopieno a ribalta

 Für Decor Oberfläche, BX und XF auf Anfrage.  
Su richiesta, per superfici Decor, BX e XF.

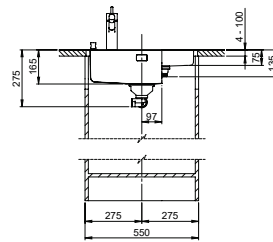
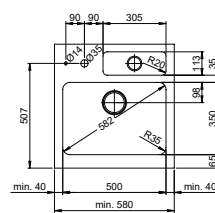
Modell Modello	Material Materiale	Ventil sFlow, Typ S Piletta sFlow, tipo S	 Prime	 in / in cm
<b>V 11</b>	Edelstahl, matt Acciaio inox, opaco	1 1/2" Stopfen / A tappo	–	◀35▶
<b>V 50-35</b>	Edelstahl, matt Acciaio inox, opaco	3 1/2" TouchFlow	–	◀55▶
		3 1/2" Raumspar / Salvaspazio 3 1/2" Tipo	✓	
<b>V 50-35 + V 11</b>	Edelstahl, matt Acciaio inox, opaco	3 1/2" TouchFlow + 1 1/2" Stopfen / A tappo	–	◀55▶
		3 1/2" Raumspar / Salvaspazio + 1 1/2" Stopfen / A tappo 3 1/2" Tipo + 1 1/2" Stopfen / A tappo	✓	



 Für Decor Oberfläche, BX und XF auf Anfrage.  
Su richiesta, per superfici Decor, BX e XF.

Modell Modello	Material Materiale	Ventil sFlow, Typ M Piletta sFlow, tipo M	 Advant	 in / in cm
<b>V 11</b>	Edelstahl, matt Acciaio inox, opaco	1 1/2" Stopfen / A tappo	–	◀35▶
<b>V 50-35</b>	Edelstahl, matt Acciaio inox, opaco	3 1/2" eFlow Desino	–	◀55▶
		3 1/2" TouchFlow Desino	–	
		3 1/2" Raumspar Desino / Salvaspazio Desino 3 1/2" Tipo Desino	✓	
<b>V 50-35 + V11</b>	Edelstahl, matt Acciaio inox, opaco	3 1/2" eFlow Desino + 1 1/2" Stopfen / A tappo	–	◀55▶
		3 1/2" TouchFlow Desino + 1 1/2" Stopfen / A tappo	–	
		3 1/2" Raumspar Desino / Salvaspazio Desino + 1 1/2" Stopfen / A tappo 3 1/2" Tipo Desino + 1 1/2" Stopfen / A tappo	✓	

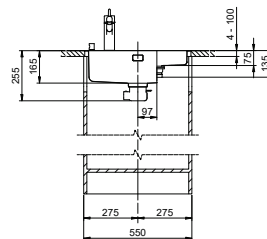
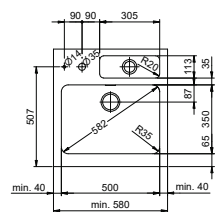

 eFlow mit eControl  
eFlow con eControl



 Schwenkbare Überlaufkappe  
Placchetta di troppopieno a ribalta



 Desino: Verdeckter Ablauf mit untenliegendem Korb  
Desino: Scarico coperto con griglietta inferiore



Für eFlow Desino  
Per eFlow Desino

Für TouchFlow Desino, Raumspar Desino und Tipo Desino  
Per TouchFlow Desino, Salvaspazio Desino e Tipo Desino



Für eFlow Desino, TouchFlow Desino, Raumspar Desino und Tipo Desino  
Per eFlow Desino, TouchFlow Desino, Salvaspazio Desino e Tipo Desino

Vantis

Küchenzubehör für Vantis siehe / Accessori per cucina per Vantis v. 



 Schwenkbare Überlaufkappe  
Placchetta di troppopieno a ribalta

Modell Modello	Material Materiale	Ventil sFlow, Typ S Piletta sFlow, tipo S	 Prime	 in / in cm
V 55	Edelstahl, matt Acciaio inox, opaco	3 1/2" TouchFlow	–	◀60▶
		3 1/2" Raumspar / Salvaspazio	✓	
		3 1/2" Tipo	–	

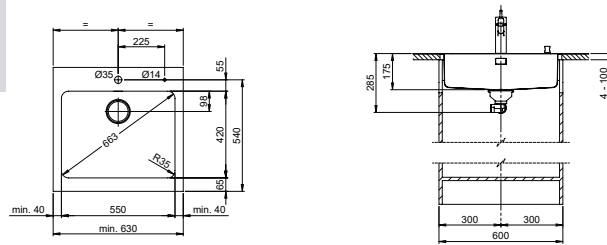

Massanfertigungen  
Soluzioni a misura



 eFlow mit eControl  
eFlow con eControl



 13

 Schwenkbare Überlaufkappe  
Placchetta di troppopieno a ribalta

 13

 Desino: Verdeckter Ablauf mit untenliegendem Korb  
Desino: Scarico coperto con griglietta inferiore

 12

Modell Modello	Material Materiale	Ventil sFlow, Typ M Piletta sFlow, tipo M	 Advant	 in / in cm
V 55	Edelstahl, matt Acciaio inox, opaco	3 1/2" eFlow Desino	–	◀60▶
		3 1/2" TouchFlow Desino	–	
		3 1/2" Raumspar Desino / Salvaspazio Desino	✓	
		3 1/2" Tipo Desino	–	

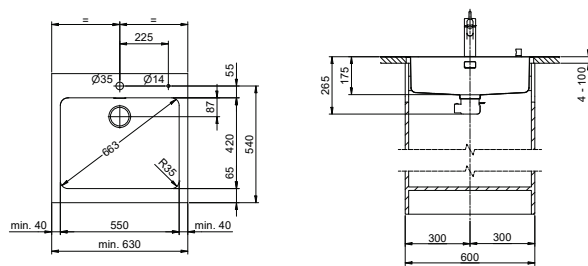

Für eFlow Desino  
Per eFlow Desino



Für TouchFlow Desino, Raumspar Desino und Tipo Desino  
Per TouchFlow Desino, Salvaspazio Desino e Tipo Desino





Für eFlow Desino, TouchFlow Desino, Raumspar Desino und Tipo Desino  
Per eFlow Desino, TouchFlow Desino, Salvaspazio Desino e Tipo Desino





## Vantis

Küchenzubehör für Vantis siehe / Accessori per cucina per Vantis v. 

 Schwenkbare Überlaufkappe  
Placchetta di troppopieno a ribalta

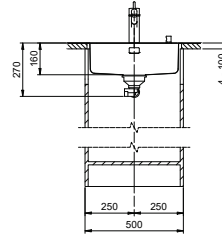
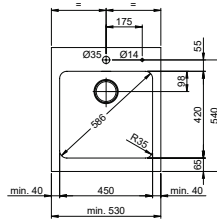

Modell Modello	Material Materiale	Ventil sFlow, Typ S Piletta sFlow, tipo S	 Advant	 in / in cm
VG 45 Green	Edelstahl, matt Acciaio inox, opaco	3 1/2" TouchFlow	–	◀50▶
		3 1/2" Raumspar / Salvaspazio	✓	
		3 1/2" Tipo	–	





 Green Line ist eine eigenständige auf Nachhaltigkeit ausgerichtete Produktausführung. Green Line è una versione di prodotto autonoma calibrata sulla sostenibilità.

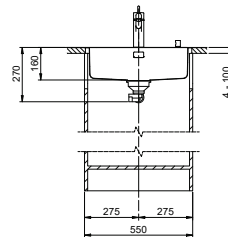
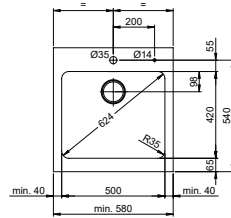

 Schwenkbare Überlaufkappe  
Placchetta di troppopieno a ribalta

Modell Modello	Material Materiale	Ventil sFlow, Typ S Piletta sFlow, tipo S	 Advant	 in / in cm
VG 50-42 Green	Edelstahl, matt Acciaio inox, opaco	3 1/2" TouchFlow	–	◀55▶
		3 1/2" Raumspar / Salvaspazio	✓	
		3 1/2" Tipo	–	





 Green Line ist eine eigenständige auf Nachhaltigkeit ausgerichtete Produktausführung. Green Line è una versione di prodotto autonoma calibrata sulla sostenibilità.

Vantis

Küchenzubehör für Vantis siehe / Accessori per cucina per Vantis v. 



 Schwenkbare Überlaufkappe  
Placchetta di troppopieno a ribalta

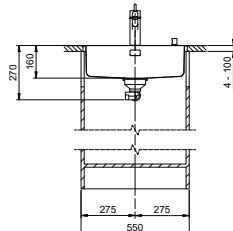
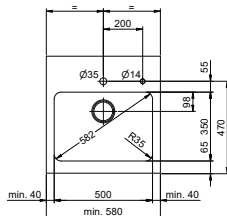

Modell Modello	Material Materiale	Ventil sFlow, Typ S Piletta sFlow, tipo S	 Advant	 in / in cm
VG 50-35 Green	Edelstahl, matt Acciaio inox, opaco	3 1/2" TouchFlow	–	◀55▶
		3 1/2" Raumspar / Salvaspazio	✓	
		3 1/2" Tipo	–	



 Green Line ist eine eigenständige auf Nachhaltigkeit ausgerichtete Produktausführung. Green Line è una versione di prodotto autonoma calibrata sulla sostenibilità.



 Schwenkbare Überlaufkappe  
Placchetta di troppopieno a ribalta

Modell Modello	Material Materiale	Ventil sFlow, Typ S Piletta sFlow, tipo S	 Advant	 in / in cm
VG 55 Green	Edelstahl, matt Acciaio inox, opaco	3 1/2" TouchFlow	–	◀60▶
		3 1/2" Raumspar / Salvaspazio	✓	
		3 1/2" Tipo	–	

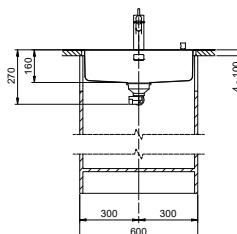
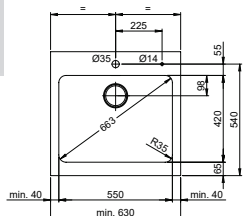

 Green Line ist eine eigenständige auf Nachhaltigkeit ausgerichtete Produktausführung. Green Line è una versione di prodotto autonoma calibrata sulla sostenibilità.

## Vantis

Küchenzubehör für Vantis siehe / Accessori per cucina per Vantis v. 

Modell Modello	Material Materiale	Ventil Piletta	 Prime	 in / in cm
<b>VX 34 Varix</b>	Edelstahl, mid-matt Acciaio inox, mid-matt	3 1/2" Raumspar / Salvaspazio	✓	◀40▶
		3 1/2" Siebstopfen / A tappo c. griglietta	–	

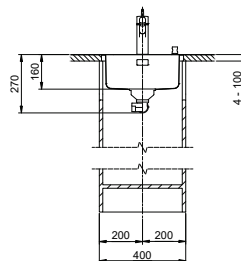
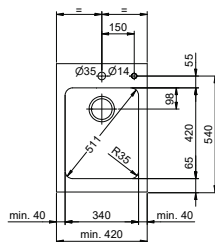

Modell Modello	Material Materiale	Ventil Piletta	 Prime	 in / in cm
<b>VX 40 Varix</b>	Edelstahl, mid-matt Acciaio inox, mid-matt	3 1/2" Raumspar / Salvaspazio	✓	◀45▶
		3 1/2" Siebstopfen / A tappo c. griglietta	–	

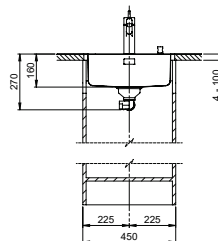
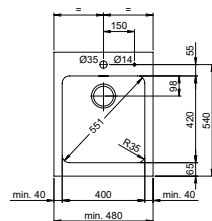

Modell Modello	Material Materiale	Ventil Piletta	 Prime	 in / in cm
<b>VX 45 Varix</b>	Edelstahl, mid-matt Acciaio inox, mid-matt	3 1/2" Raumspar / Salvaspazio	✓	◀50▶
		3 1/2" Siebstopfen / A tappo c. griglietta	–	

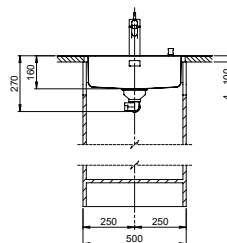
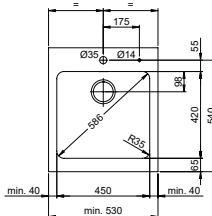

Vantis

Küchenzubehör für Vantis siehe / Accessori per cucina per Vantis v. 



Modell Modello	Material Materiale	Ventil Piletta	 Prime	 in/in cm
<b>VX 50-42 Varix</b>	Edelstahl, mid-matt	3 1/2" Raumspar / Salvaspazio	✓	◀55▶
	Acciaio inox, mid-matt	3 1/2" Siebstopfen / A tappo c. griglietta	–	

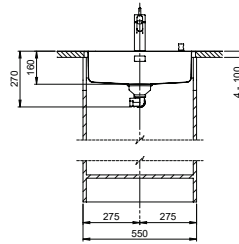
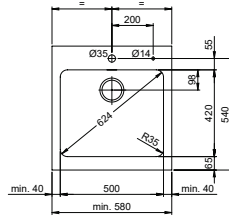

Modell Modello	Material Materiale	Ventil Piletta	 Prime	 in/in cm
<b>VX 55 Varix</b>	Edelstahl, mid-matt	3 1/2" Raumspar / Salvaspazio	✓	◀60▶
	Acciaio inox, mid-matt	3 1/2" Siebstopfen / A tappo c. griglietta	–	

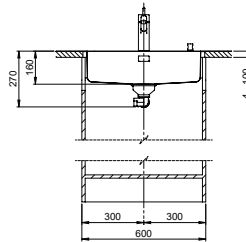
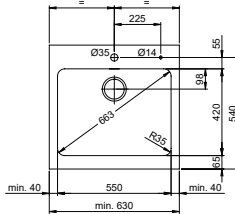





## Silver Star

Küchenzubehör für Silver Star siehe / Accessori per cucina per Silver Star v. 

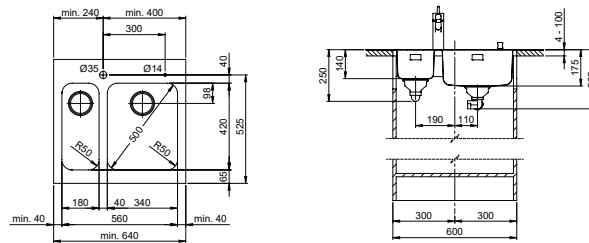
**i** Für Decor Oberfläche, BX und XF auf Anfrage.  
Su richiesta, per superfici Decor, BX e XF.

Modell Modello	Material Materiale	Ventil Piletta	 Prime	 in / in cm
<b>SIL 18</b>	Edelstahl, matt Acciaio inox, opaco	3 1/2" Tipo	–	◀35▶
	Edelstahl, glanz Acciaio inox, lucido	3 1/2" Tipo	–	
<b>SIL 34</b>	Edelstahl, matt Acciaio inox, opaco	3 1/2" Raumspar / Salvaspazio 3 1/2" Tipo	✓ –	◀40▶
	Edelstahl, glanz Acciaio inox, lucido	3 1/2" Raumspar / Salvaspazio 3 1/2" Tipo	✓ –	
	Edelstahl, matt Acciaio inox, opaco	3 1/2" Tipo + Raumspar / Tipo + Salvaspazio 3 1/2" Tipo + Tipo	✓ –	
<b>SIL 18 + SIL 34</b>	Edelstahl, matt Acciaio inox, opaco	3 1/2" Tipo + Raumspar / Tipo + Salvaspazio 3 1/2" Tipo + Tipo	✓ –	◀60▶
	Edelstahl, glanz Acciaio inox, lucido	3 1/2" Tipo + Raumspar / Tipo + Salvaspazio 3 1/2" Tipo + Tipo	✓ –	



Modell Modello	Material Materiale	Ventil Piletta	 Prime	 in / in cm
<b>SIL 45</b>	Edelstahl, matt Acciaio inox, opaco	3 1/2" Raumspar / Salvaspazio 3 1/2" Tipo	✓ –	◀50▶
	Edelstahl, glanz Acciaio inox, lucido	3 1/2" Raumspar / Salvaspazio 3 1/2" Tipo	✓ –	
	 Edelstahl, glanz Acciaio inox, lucido	Modell ist mit Überlaufschlitzen und Raumspar-Ventil ausgestattet. Beckentiefe 120 mm. Modello dotato di fessure di troppopieno e piletta salvaspazio. Profondità 120 mm.		

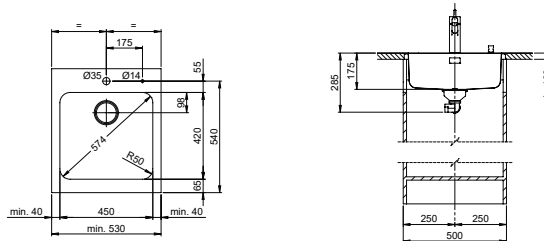

Silver Star

Küchenzubehör für Silver Star siehe / Accessori per cucina per Silver Star v. 312-314



Modell Modello	Material Materiale	Ventil Piletta	Prime	in / in cm
SIS 50	Edelstahl, matt Acciaio inox, opaco	3 1/2" Raumspar / Salvaspazio	✓	◀55▶
		3 1/2" Tipo	-	
	Edelstahl, glanz Acciaio inox, lucido	3 1/2" Raumspar / Salvaspazio	✓	
		3 1/2" Tipo	-	

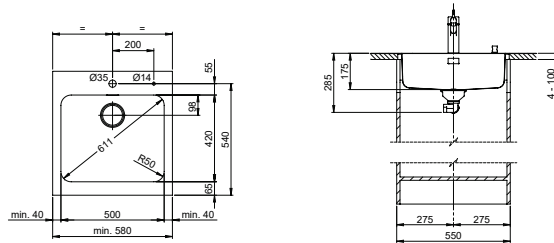

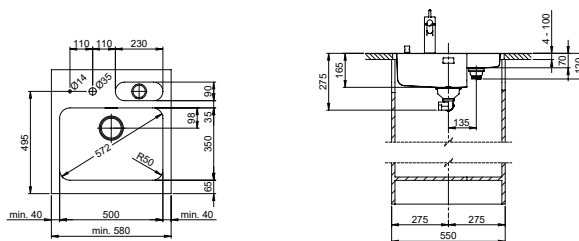

Modell Modello	Material Materiale	Ventil Piletta	Prime	in / in cm
SIL 9	Edelstahl, matt Acciaio inox, opaco	1 1/2" Stopfen / A tappo	-	◀35▶
	Edelstahl, glanz Acciaio inox, lucido	1 1/2" Stopfen / A tappo	-	
SIL 50	Edelstahl, matt Acciaio inox, opaco	3 1/2" Raumspar / Salvaspazio	✓	◀55▶
		3 1/2" Tipo	-	
	Edelstahl, glanz Acciaio inox, lucido	3 1/2" Tipo	-	
SIL 50 + SIL 9	Edelstahl, matt Acciaio inox, opaco	3 1/2" Raumspar / Salvaspazio + 1 1/2" Stopfen / A tappo	✓	◀55▶
		3 1/2" Tipo + 1 1/2" Stopfen / A tappo	-	
	Edelstahl, glanz Acciaio inox, lucido	3 1/2" Raumspar / Salvaspazio + 1 1/2" Stopfen / A tappo	✓	
		3 1/2" Tipo + 1 1/2" Stopfen / A tappo	-	



**i** Für Decor Oberfläche, BX und XF auf Anfrage.  
Su richiesta, per superfici Decor, BX e XF.

## Silver Star

Küchenzubehör für Silver Star siehe / Accessori per cucina per Silver Star v. 

Modell Modello	Material Materiale	Ventil Piletta	 Prime	 in / in cm
SIL 55	Edelstahl, matt Acciaio inox, opaco	3 1/2" Raumspar / Salvaspazio	✓	◀60▶
		3 1/2" Tipo	-	
	Edelstahl, glanz Acciaio inox, lucido	3 1/2" Raumspar / Salvaspazio	✓	
		3 1/2" Tipo	-	

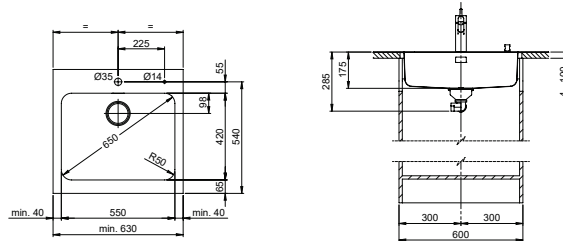

Modell Modello	Material Materiale	Ventil Piletta	 Prime	 in / in cm
SX 40 Varix	Edelstahl, mid-matt Eco Acciaio inox, mid-matt Eco	3 1/2" Raumspar / Salvaspazio	✓	◀45▶
		3 1/2" Siebstopfen / A tappo c. griglietta	-	

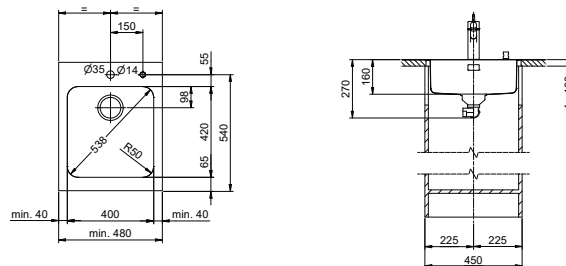

Modell Modello	Material Materiale	Ventil Piletta	 Prime	 in / in cm
SX 50-42 Varix	Edelstahl, mid-matt Eco Acciaio inox, mid-matt Eco	3 1/2" Raumspar / Salvaspazio	✓	◀55▶
		3 1/2" Siebstopfen / A tappo c. griglietta	-	

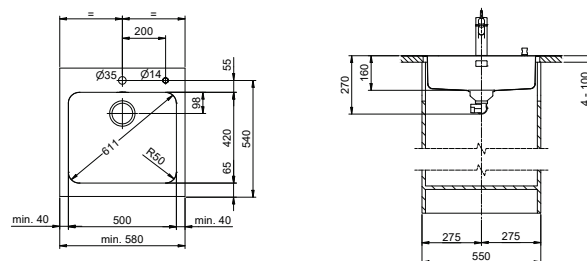

Comfort

Küchenzubehör für Comfort siehe/Accessori per cucina per Comfort v.  312-314



Modell Modello	Material Materiale	Ventil Piletta	 Prime	 in / in cm
<b>COM 34</b>	Edelstahl, glanz Acciaio inox, lucido	3 1/2" Raumspar / Salvaspazio	✓	◀40▶
		3 1/2" Tipo	-	
		1 1/2" Standrohr / Con tubo	-	

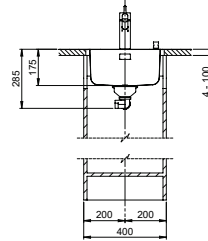
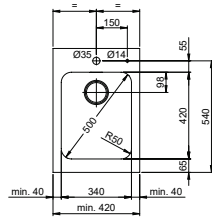

Modell Modello	Material Materiale	Ventil Piletta	 Prime	 in / in cm
<b>COM 40</b>	Edelstahl, glanz Acciaio inox, lucido	3 1/2" Raumspar / Salvaspazio	✓	◀45▶
		3 1/2" Tipo	-	

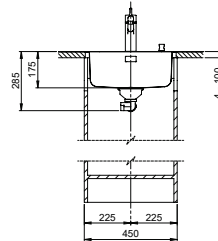
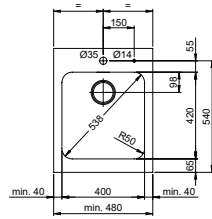

## Gastro MaXX

Küchenzubehör für Gastro MaXX siehe / Accessori per cucina per Gastro MaXX v. 

**i** Für Decor Oberfläche, BX und XF auf Anfrage.  
Su richiesta, per superfici Decor, BX e XF.

Modell Modello	Material Materiale	Ventil Piletta	 Advant	 in / in cm
<b>MGM 1</b>	Edelstahl, glanz Acciaio inox, lucido	3 1/2" Raumspar / Salvaspazio	✓	«XX»
		3 1/2" Siebstopfen / A tappo c. griglietta	–	

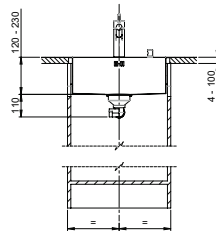
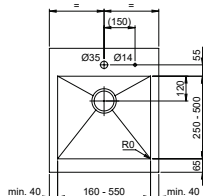

Individuelle Beckengröße möglich  
Dimensioni di lavello personalizzabili



**i** Für Decor Oberfläche, BX und XF auf Anfrage.  
Su richiesta, per superfici Decor, BX e XF.

Modell Modello	Material Materiale	Ventil Piletta	 Advant	 in / in cm
<b>MGM 2</b>	Edelstahl, glanz Acciaio inox, lucido	3 1/2" Raumspar / Salvaspazio	✓	«XX»
		3 1/2" Siebstopfen / A tappo c. griglietta	–	

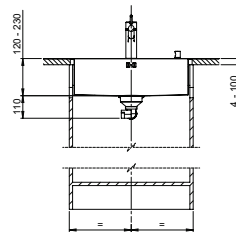
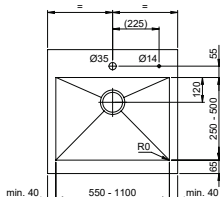

Individuelle Beckengröße möglich  
Dimensioni di lavello personalizzabili

## Rund



**i** Für Decor Oberfläche, BX und XF auf Anfrage.  
Su richiesta, per superfici Decor, BX e XF.

Modell Modello	Material Materiale	Ventil Piletta	 Prime	 in / in cm
<b>R 44</b>	Edelstahl, glanz Acciaio inox, lucido	3 1/2" Raumspar / Salvaspazio	✓	«45»
		3 1/2" Tipo	–	

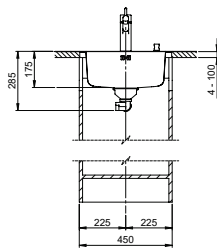
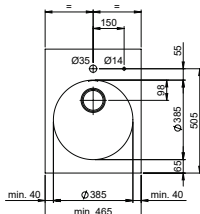

Accento

Küchenzubehör für Accento siehe / Accessori per cucina per Accento v. 312-314



Schwenkbare Überlaufkappe  
Placchetta di troppopieno a ribalta

Für Decor Oberfläche, BX und XF auf Anfrage.  
Su richiesta, per superfici Decor, BX e XF.

Modell Modello	Material Materiale	Ventil Piletta	Advant	in / in cm
A 65	Edelstahl, glanz Acciaio inox, lucido	3 1/2" TouchFlow	–	◀80▶
		3 1/2" Raumspar / Salvaspazio	✓	
		3 1/2" Tipo	–	

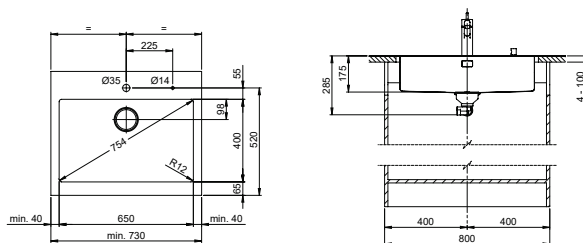

Schwenkbare Überlaufkappe  
Placchetta di troppopieno a ribalta

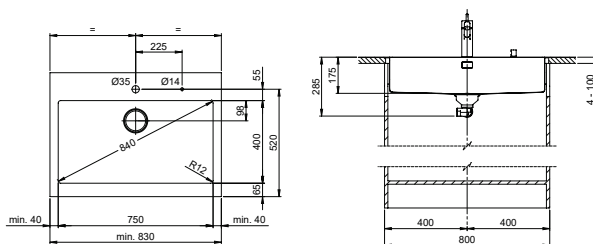

Für Decor Oberfläche, BX und XF auf Anfrage.  
Su richiesta, per superfici Decor, BX e XF.

Modell Modello	Material Materiale	Ventil Piletta	Advant	in / in cm
A 75	Edelstahl, glanz Acciaio inox, lucido	3 1/2" TouchFlow	–	◀80▶
		3 1/2" Raumspar / Salvaspazio	✓	
		3 1/2" Tipo	–	



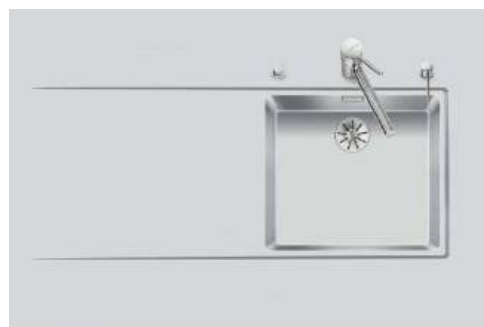

## Starline Pure

Küchenzubehör ab Seite / Accessori a partire dalla pagina  312

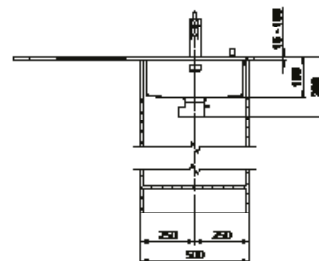
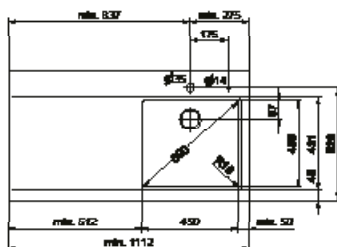

Modell Modello	Material Materiale	Ventil sFlow, Typ M Piletta sFlow, tipo M	 Advant	 in / in cm
Linero LIO 45	Edelstahl, matt Acciaio inox, opaco	3 1/2" TouchFlow	–	◀50▶
		3 1/2" Druckknopf / Pulsante <span style="color: blue;">new</span>	–	
		3 1/2" Raumspar / Salvaspazio	✓	
		3 1/2" Tipo	–	

 Version Tropfteil links oder rechts erhältlich. Erhältlich für SmartSteel Collection in folgenden Oberflächen:  
Scolatoio disponibile in versione per posizionamento a sinistra o a destra. Disponibile per SmartSteel Collection nelle seguenti finiture:

Standard  SF  BF  WF

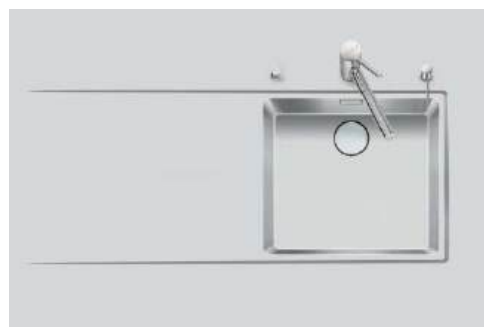
 Schwenkbare Überlaufkappe  
Placchetta di troppopieno a ribalta



Modell Modello	Material Materiale	Ventil sFlow, Typ M Piletta sFlow, tipo M	 Advant	 in / in cm
Linero LIO 45	Edelstahl, matt Acciaio inox, opaco	3 1/2" eFlow Desino	–	◀50▶
		3 1/2" TouchFlow Desino	–	
		3 1/2" Raumspar Desino / Salvaspazio Desino	✓	
		3 1/2" Tipo Desino	–	

 Version Tropfteil links oder rechts erhältlich. Erhältlich für SmartSteel Collection in folgenden Oberflächen:  
Scolatoio disponibile in versione per posizionamento a sinistra o a destra. Disponibile per SmartSteel Collection nelle seguenti finiture:

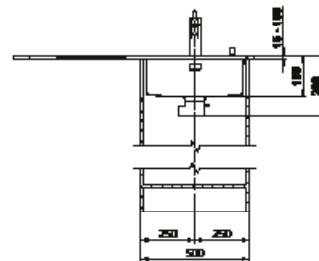
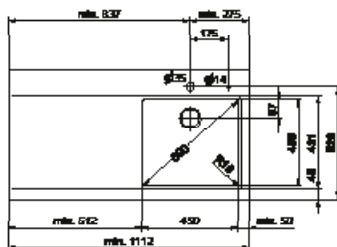
Standard  SF  BF  WF

 eFlow mit eControl  
eFlow con eControl



 Schwenkbare Überlaufkappe  
Placchetta di troppopieno a ribalta



 Desino: Verdeckter Ablauf mit untenliegendem Korb  
Desino: Scarico coperto con griglietta inferiore



Für eFlow Desino  
Per eFlow Desino



Für TouchFlow Desino, Raumspar Desino und Tipo Desino  
Per TouchFlow Desino, Salvaspazio Desino e Tipo Desino



Für eFlow Desino, TouchFlow Desino, Raumspar Desino und Tipo Desino  
Per eFlow Desino, TouchFlow Desino, Salvaspazio Desino e Tipo Desino

## Standardoberflächen / Superfici standard

SF	Seidenmatt-Finish / Finitura satinata
BF	Breitband-Finish / Finitura a nastro largo
BX	Breitband Varix / Nastro largo Varix
WF	Wirbel-Finish / Finitura a turbino

## Decor Oberflächen / Superfici Decor

PS	Polaris Silver
PB	Polaris Black
TR	Terra

## Spezialoberflächen / Superfici speciali

ID	IceDesign	PL	Polar Look	XB	Xrange Black
BI	BlackRange Industrial	XI	Xrange Ice	SL	Silk Look
BP	BlackRange Passion	XF	Xrange Fineline	WG	Warmgewalzt Laminazione a caldo

## Ausführung / Lavorazione

 Green Line

Alle Massangaben in mm  
Unità di misura in mm

Starline Pure

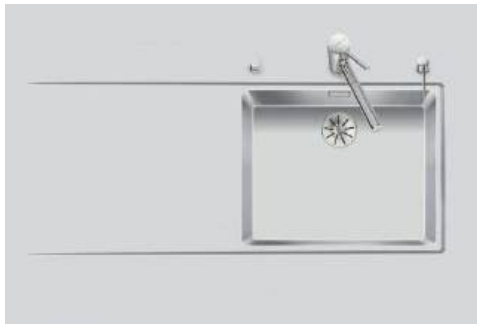

Küchenzubehör ab Seite / Accessori a partire dalla pagina  312





 Version Tropfteil links oder rechts erhältlich. Erhältlich für SmartSteel Collection in folgenden Oberflächen:  
Scolatoio disponibile in versione per posizionamento a sinistra o a destra. Disponibile per SmartSteel Collection nelle seguenti finiture:

Standard  SF  BF  WF

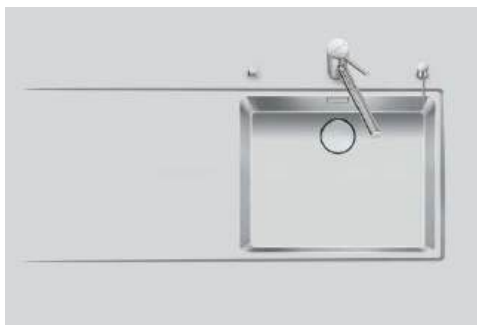
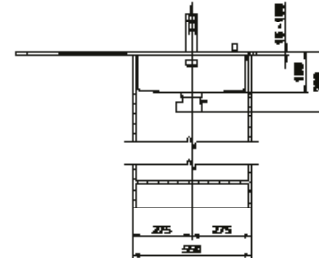
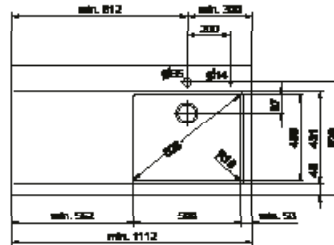

 Schwenkbare Überlaufkappe  
Placchetta di troppopieno a ribalta

Modell Modello	Material Materiale	Ventil sFlow, Typ M Piletta sFlow, tipo M	 Advant	 in / in cm
Linero LIO 50	Edelstahl, matt Acciaio inox, opaco	3 1/2" TouchFlow	–	◀55▶
		3 1/2" Druckknopf / Pulsante <span style="color: blue;">new</span>	–	
		3 1/2" Raumspar / Salvaspazio	✓	
		3 1/2" Tipo	–	



 Version Tropfteil links oder rechts erhältlich. Erhältlich für SmartSteel Collection in folgenden Oberflächen:  
Scolatoio disponibile in versione per posizionamento a sinistra o a destra. Disponibile per SmartSteel Collection nelle seguenti finiture:

Standard  SF  BF  WF

Modell Modello	Material Materiale	Ventil sFlow, Typ M Piletta sFlow, tipo M	 Advant	 in / in cm
Linero LIO 50	Edelstahl, matt Acciaio inox, opaco	3 1/2" eFlow Desino	–	◀55▶
		3 1/2" TouchFlow Desino	–	
		3 1/2" Raumspar Desino / Salvaspazio Desino	✓	
		3 1/2" Tipo Desino	–	

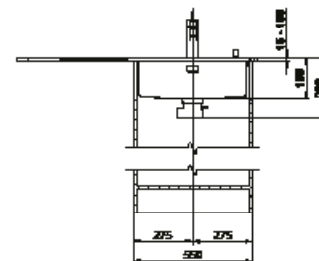
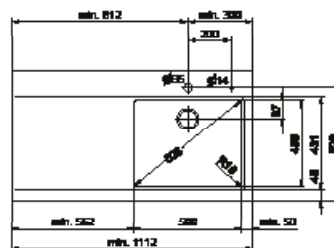

 eFlow mit eControl  
eFlow con eControl

 13

 Schwenkbare Überlaufkappe  
Placchetta di troppopieno a ribalta

 13

 Desino: Verdeckter Ablauf mit untenliegendem Korb  
Desino: Scarico coperto con griglietta inferiore

 12



Für eFlow Desino  
Per eFlow Desino



Für TouchFlow Desino, Raumspar Desino und Tipo Desino  
Per TouchFlow Desino, Salvaspazio Desino e Tipo Desino



Für eFlow Desino, TouchFlow Desino, Raumspar Desino und Tipo Desino  
Per eFlow Desino, TouchFlow Desino, Salvaspazio Desino e Tipo Desino



Standardoberflächen / Superfici standard

SF	Seidenmatt-Finish / Finitura satinata
BF	Breitband-Finish / Finitura a nastro largo
BX	Breitband Varix / Nastro largo Varix
WF	Wirbel-Finish / Finitura a turbino

Decor Oberflächen / Superfici Decor

PS	Polaris Silver
PB	Polaris Black
TR	Terra

Spezialoberflächen / Superfici speciali

ID	IceDesign	PL	Polar Look
BI	BlackRange Industrial	XI	Xrange Ice
BP	BlackRange Passion	XF	Xrange Fineline

XB	Xrange Black
SL	Silk Look
WG	Warmgewalzt Laminazione a caldo

Ausführung / Lavorazione

 Green Line

Alle Massangaben in mm  
Unità di misura in mm

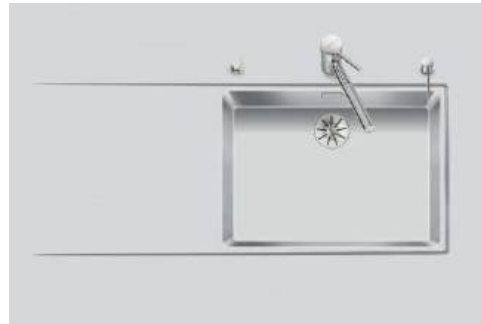

## Starline Pure

Küchenzubehör ab Seite / Accessori a partire dalla pagina  312

**i** Version Tropfteil links oder rechts erhältlich. Erhältlich für SmartSteel Collection in folgenden Oberflächen:  
Scolatoio disponibile in versione per posizionamento a sinistra o a destra. Disponibile per SmartSteel Collection nelle seguenti finiture:

Standard **SF** **BF** **WF**

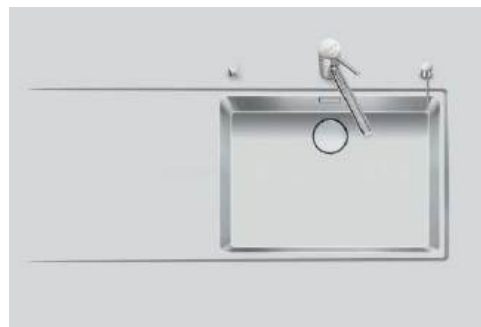
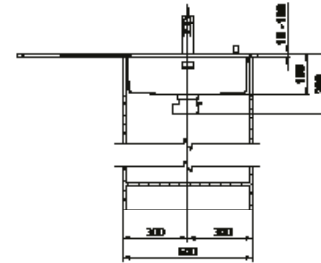
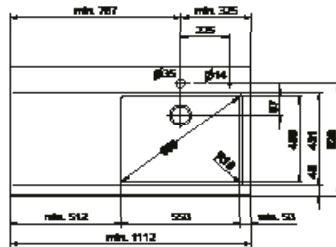

 Schwenkbare Überlaufkappe  
Placchetta di troppopieno a ribalta

Modell Modello	Material Materiale	Ventil sFlow, Typ M Piletta sFlow, tipo M	 Advant	 in / in cm
<b>Linero LIO 55</b>	Edelstahl, matt Acciaio inox, opaco	3 1/2" TouchFlow	–	◀60▶
		3 1/2" Druckknopf / Pulsante <b>new</b>	–	
		3 1/2" Raumspar / Salvaspazio	✓	
		3 1/2" Tipo	–	



**i** Version Tropfteil links oder rechts erhältlich. Erhältlich für SmartSteel Collection in folgenden Oberflächen:  
Scolatoio disponibile in versione per posizionamento a sinistra o a destra. Disponibile per SmartSteel Collection nelle seguenti finiture:

Standard **SF** **BF** **WF**

Modell Modello	Material Materiale	Ventil sFlow, Typ M Piletta sFlow, tipo M	 Advant	 in / in cm
<b>Linero LIO 55</b>	Edelstahl, matt Acciaio inox, opaco	3 1/2" eFlow Desino	–	◀60▶
		3 1/2" TouchFlow Desino	–	
		3 1/2" Raumspar Desino / Salvaspazio Desino	✓	
		3 1/2" Tipo Desino	–	

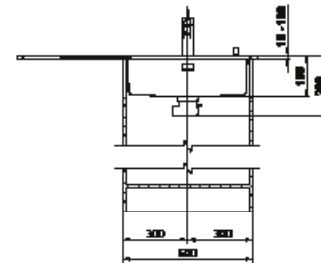
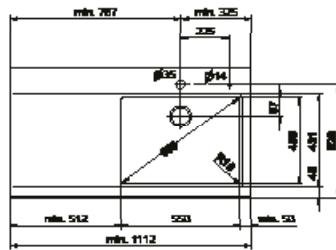

 eFlow mit eControl  
eFlow con eControl



 Schwenkbare Überlaufkappe  
Placchetta di troppopieno a ribalta



 Desino: Verdeckter Ablauf mit untenliegendem Korb  
Desino: Scarico coperto con griglietta inferiore



Für eFlow Desino  
Per eFlow Desino

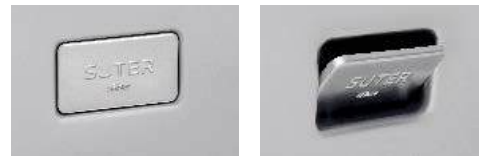

Für TouchFlow Desino, Raumspar Desino und Tipo Desino  
Per TouchFlow Desino, Salvaspazio Desino e Tipo Desino



Für eFlow Desino, TouchFlow Desino, Raumspar Desino und Tipo Desino  
Per eFlow Desino, TouchFlow Desino, Salvaspazio Desino e Tipo Desino

## Standardoberflächen / Superfici standard

SF	Seidenmatt-Finish / Finitura satinata
BF	Breitband-Finish / Finitura a nastro largo
BX	Breitband Varix / Nastro largo Varix
WF	Wirbel-Finish / Finitura a turbinio

## Decor Oberflächen / Superfici Decor

PS	Polaris Silver
PB	Polaris Black
TR	Terra

## Spezialoberflächen / Superfici speciali

ID	IceDesign	PL	Polar Look
BI	BlackRange Industrial	XI	Xrange Ice
BP	BlackRange Passion	XF	Xrange Fineline

XB	Xrange Black
SL	Silk Look
WG	Warmgewalzt Laminazione a caldo

## Ausführung / Lavorazione

 Green Line

Alle Massangaben in mm  
Unità di misura in mm

Starline Pure

Küchenzubehör ab Seite / Accessori a partire dalla pagina 312

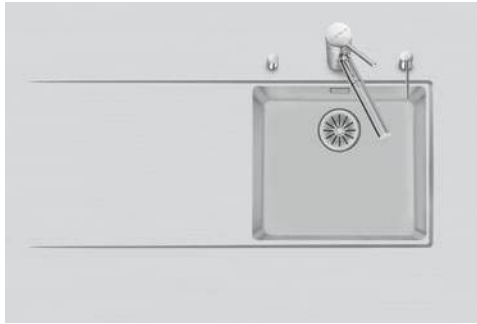

Modell Modello	Material Materiale	Ventil sFlow, Typ S Piletta sFlow, tipo S	Advant	in / in cm
Daneo DAN 45	Edelstahl, matt Acciaio inox, opaco	3 1/2" TouchFlow	–	◀50▶
		3 1/2" Raumspar / Salvaspazio	✓	
		3 1/2" Tipo	–	

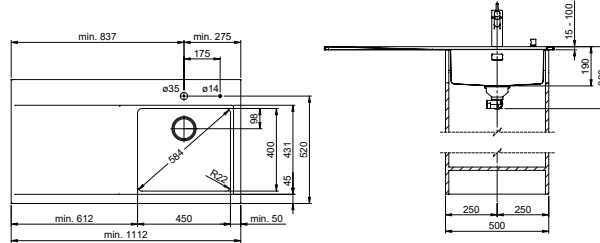

Schwenkbare Überlaufkappe  
Placchetta di troppopieno a ribalta

Version Tropfteil links oder rechts erhältlich. Erhältlich für SmartSteel Collection in folgenden Oberflächen:  
Scolatoio disponibile in versione per posizionamento a sinistra o a destra. Disponibile per SmartSteel Collection nelle seguenti finiture:

Standard SF BF WF

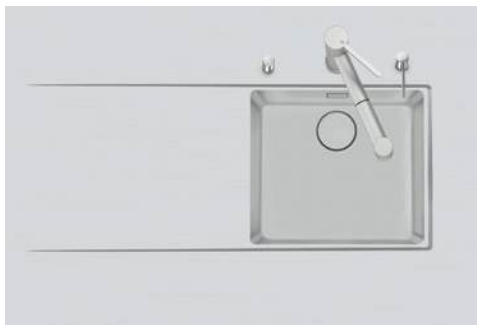

Modell Modello	Material Materiale	Ventil sFlow, Typ M Piletta sFlow, tipo M	Advant	in / in cm
Daneo DAN 45	Edelstahl, matt Acciaio inox, opaco	3 1/2" eFlow Desino	–	◀50▶
		3 1/2" TouchFlow Desino	–	
		3 1/2" Raumspar Desino / Salvaspazio Desino	✓	
		3 1/2" Tipo Desino	–	

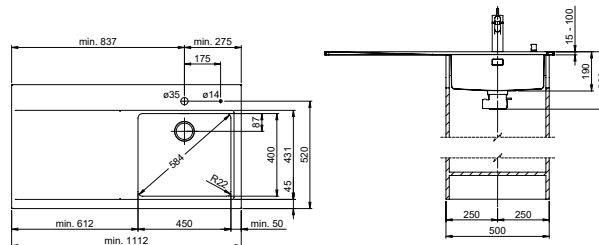

Version Tropfteil links oder rechts erhältlich. Erhältlich für SmartSteel Collection in folgenden Oberflächen:  
Scolatoio disponibile in versione per posizionamento a sinistra o a destra. Disponibile per SmartSteel Collection nelle seguenti finiture:

Standard SF BF WF

eFlow mit eControl  
eFlow con eControl



Schwenkbare Überlaufkappe  
Placchetta di troppopieno a ribalta



Desino: Verdeckter Ablauf mit untenliegendem Korb  
Desino: Scarico coperto con griglietta inferiore



Für eFlow Desino  
Per eFlow Desino

Für TouchFlow Desino, Raumspar Desino und Tipo Desino  
Per TouchFlow Desino, Salvaspazio Desino e Tipo Desino

Für eFlow Desino, TouchFlow Desino, Raumspar Desino und Tipo Desino  
Per eFlow Desino, TouchFlow Desino, Salvaspazio Desino e Tipo Desino

Standardoberflächen / Superfici standard

SF	Seidenmatt-Finish / Finitura satinata
BF	Breitband-Finish / Finitura a nastro largo
BX	Breitband Varix / Nastro largo Varix
WF	Wirbel-Finish / Finitura a turbinio

Decor Oberflächen / Superfici Decor

PS	Polaris Silver
PB	Polaris Black
TR	Terra

Spezialoberflächen / Superfici speciali

ID	IceDesign	PL	Polar Look	XB	Xrange Black
BI	BlackRange Industrial	XI	Xrange Ice	SL	Silk Look
BP	BlackRange Passion	XF	Xrange Fineline	WG	Warmgewalzt Laminazione a caldo

Ausführung / Lavorazione

GREEN LINE Green Line

Alle Massangaben in mm  
Unità di misura in mm

Starline Pure

Küchenzubehör ab Seite / Accessori a partire dalla pagina 312

Massenfertigungen  
Soluzioni a misura

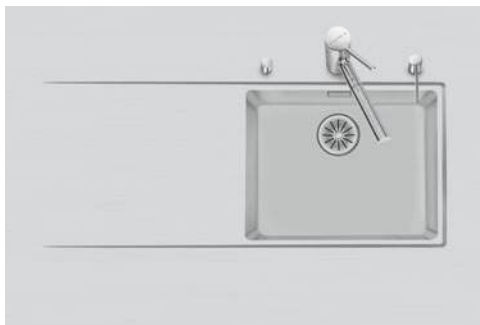

Modell Modello	Material Materiale	Ventil sFlow, Typ S Piletta sFlow, tipo S	Advant	in / in cm
Daneo DAN 50	Edelstahl, matt Acciaio inox, opaco	3 1/2" TouchFlow	–	◀55▶
		3 1/2" Raumspar / Salvaspazio	✓	
		3 1/2" Tipo	–	

Schwenkbare Überlaufkappe  
Placchetta di troppopieno a ribalta

Version Tropfteil links oder rechts erhältlich. Erhältlich für SmartSteel Collection in folgenden Oberflächen:  
Scolatoio disponibile in versione per posizionamento a sinistra o a destra. Disponibile per SmartSteel Collection nelle seguenti finiture:

Standard SF BF WF

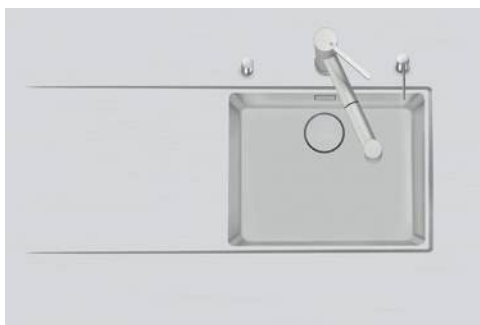
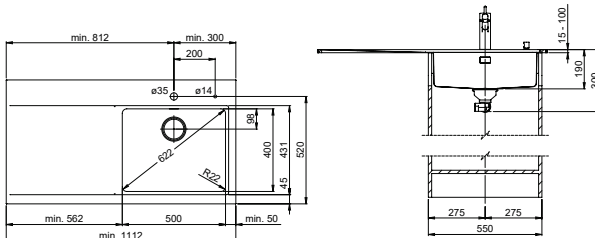

Modell Modello	Material Materiale	Ventil sFlow, Typ M Piletta sFlow, tipo M	Advant	in / in cm
Daneo DAN 50	Edelstahl, matt Acciaio inox, opaco	3 1/2" eFlow Desino	–	◀55▶
		3 1/2" TouchFlow Desino	–	
		3 1/2" Raumspar Desino / Salvaspazio Desino	✓	
		3 1/2" Tipo Desino	–	

Version Tropfteil links oder rechts erhältlich. Erhältlich für SmartSteel Collection in folgenden Oberflächen:  
Scolatoio disponibile in versione per posizionamento a sinistra o a destra. Disponibile per SmartSteel Collection nelle seguenti finiture:

Standard SF BF WF

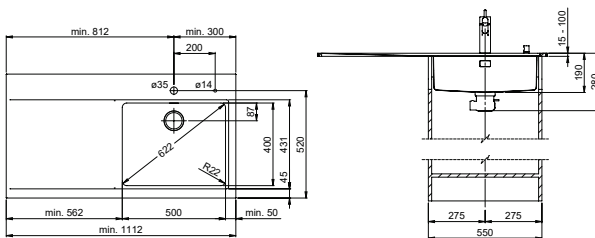

eFlow mit eControl  
eFlow con eControl

13

Schwenkbare Überlaufkappe  
Placchetta di troppopieno a ribalta

13

Desino: Verdeckter Ablauf mit untenliegendem Korb  
Desino: Scarico coperto con griglietta inferiore 12



Für eFlow Desino  
Per eFlow Desino

Für TouchFlow Desino, Raumspar Desino und Tipo Desino  
Per TouchFlow Desino, Salvaspazio Desino e Tipo Desino

Für eFlow Desino, TouchFlow Desino, Raumspar Desino und Tipo Desino  
Per eFlow Desino, TouchFlow Desino, Salvaspazio Desino e Tipo Desino

Standardoberflächen / Superfici standard

SF	Seidenmatt-Finish / Finitura satinata
BF	Breitband-Finish / Finitura a nastro largo
BX	Breitband Varix / Nastro largo Varix
WF	Wirbel-Finish / Finitura a turbino

Decor Oberflächen / Superfici Decor

PS	Polaris Silver
PB	Polaris Black
TR	Terra

Spezialoberflächen / Superfici speciali

ID	IceDesign	PL	Polar Look
BI	BlackRange Industrial	XI	Xrange Ice
BP	BlackRange Passion	XF	Xrange Fineline

XB	Xrange Black
SL	Silk Look
WG	Warmgewalzt Laminazione a caldo

Ausführung / Lavorazione

Green Line

Alle Massangaben in mm  
Unità di misura in mm

Starline Pure

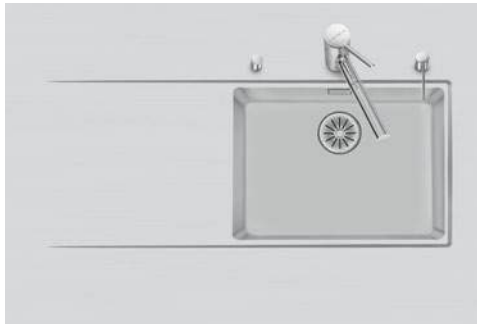

Küchenzubehör ab Seite / Accessori a partire dalla pagina  312





 Schwenkbare Überlaufkappe  
Placchetta di troppopieno a ribalta

 Version Tropfteil links oder rechts erhältlich. Erhältlich für SmartSteel Collection in folgenden Oberflächen:  
Scolatoio disponibile in versione per posizionamento a sinistra o a destra. Disponibile per SmartSteel Collection nelle seguenti finiture:

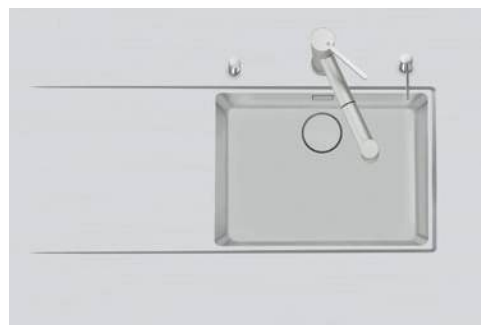
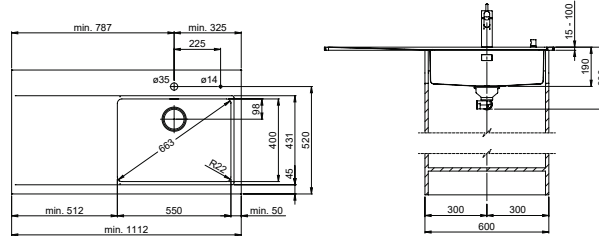

Standard  SF  BF  WF

Modell Modello	Material Materiale	Ventil sFlow, Typ S Piletta sFlow, tipo S	 Advant	 in / in cm
Daneo DAN 55	Edelstahl, matt Acciaio inox, opaco	3 1/2" TouchFlow	–	◀60▶
		3 1/2" Raumspar / Salvaspazio	✓	
		3 1/2" Tipo	–	



 Version Tropfteil links oder rechts erhältlich. Erhältlich für SmartSteel Collection in folgenden Oberflächen:  
Scolatoio disponibile in versione per posizionamento a sinistra o a destra. Disponibile per SmartSteel Collection nelle seguenti finiture:

Standard  SF  BF  WF

Modell Modello	Material Materiale	Ventil sFlow, Typ M Piletta sFlow, tipo M	 Advant	 in / in cm
Daneo DAN 55	Edelstahl, matt Acciaio inox, opaco	3 1/2" eFlow Desino	–	◀60▶
		3 1/2" TouchFlow Desino	–	
		3 1/2" Raumspar Desino / Salvaspazio Desino	✓	
		3 1/2" Tipo Desino	–	

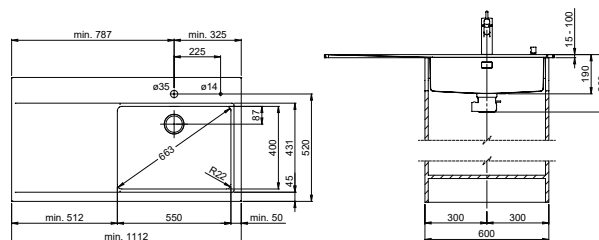

 eFlow mit eControl  
eFlow con eControl



 Schwenkbare Überlaufkappe  
Placchetta di troppopieno a ribalta



 Desino: Verdeckter Ablauf mit untenliegendem Korb  
Desino: Scarico coperto con griglietta inferiore



Für eFlow Desino  
Per eFlow Desino



Für TouchFlow Desino, Raumspar Desino und Tipo Desino  
Per TouchFlow Desino, Salvaspazio Desino e Tipo Desino



Für eFlow Desino, TouchFlow Desino, Raumspar Desino und Tipo Desino  
Per eFlow Desino, TouchFlow Desino, Salvaspazio Desino e Tipo Desino

Standardoberflächen / Superfici standard

SF	Seidenmatt-Finish / Finitura satinata
BF	Breitband-Finish / Finitura a nastro largo
BX	Breitband Varix / Nastro largo Varix
WF	Wirbel-Finish / Finitura a turbino

Decor Oberflächen / Superfici Decor

PS	Polaris Silver
PB	Polaris Black
TR	Terra

Spezialoberflächen / Superfici speciali

ID	IceDesign	PL	Polar Look
BI	BlackRange Industrial	XI	Xrange Ice
BP	BlackRange Passion	XF	Xrange Fineline

XB	Xrange Black
SL	Silk Look
WG	Warmgewalzt Laminazione a caldo

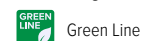

Ausführung / Lavorazione

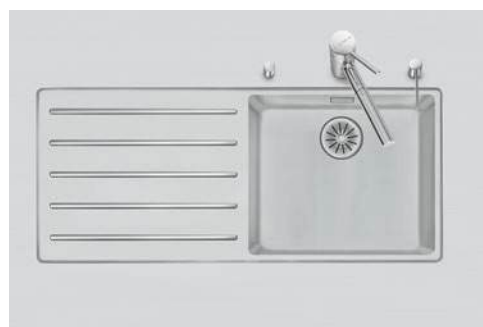
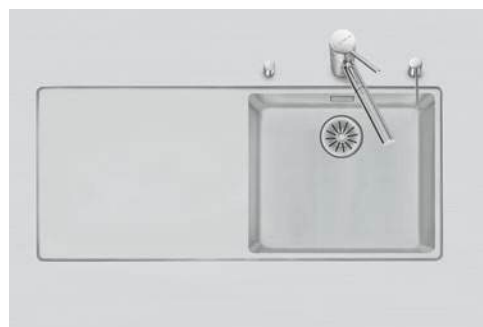

Alle Massangaben in mm  
Unità di misura in mm

## Ambio

Küchenzubehör ab Seite / Accessori a partire dalla pagina  312

Modell Modello	Material Materiale	Ventil sFlow, Typ S Piletta sFlow, tipo S	 Advant	 in / in cm
<b>Daneo DAN 100-45 EL Ambio</b>	Edelstahl, matt Acciaio inox, opaco	3 1/2" TouchFlow	–	<50>
		3 1/2" Raumspar / Salvaspazio	✓	
		3 1/2" Tipo	–	
<b>Daneo DAN 100-45 Ambio (mit Riffel / con scanalatura)</b>	Edelstahl, matt Acciaio inox, opaco	3 1/2" TouchFlow	–	
		3 1/2" Raumspar / Salvaspazio	✓	
		3 1/2" Tipo	–	

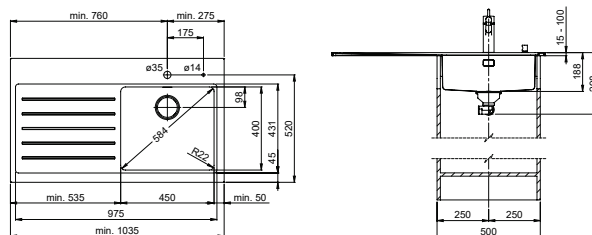



Masse für Variante ohne Riffel identisch.  
Dimensioni identiche per variante senza scanalatura.

 Schwenkbare Überlaufkappe  
Placchetta di troppopieno a ribalta

 Version Tropfteil links oder rechts erhältlich. Erhältlich für SmartSteel Collection in folgenden Oberflächen:  
Scolatoio disponibile in versione per posizionamento a sinistra o a destra. Disponibile per SmartSteel Collection nelle seguenti finiture:

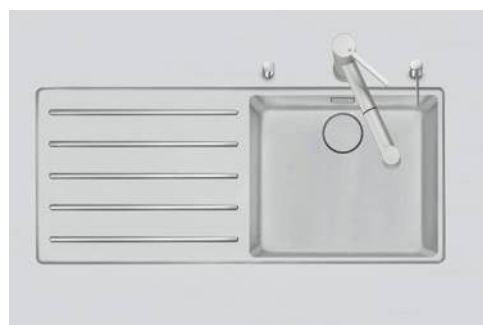
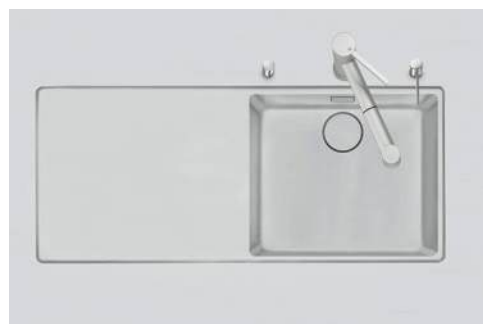
Standard SF BF WF



Modell Modello	Material Materiale	Ventil sFlow, Typ M Piletta sFlow, tipo M	 Advant	 in / in cm
<b>Daneo DAN 100-45 EL Ambio</b>	Edelstahl, matt Acciaio inox, opaco	3 1/2" eFlow Desino	–	<50>
		3 1/2" TouchFlow Desino	–	
		3 1/2" Raumspar Desino / Salvaspazio Desino	✓	
		3 1/2" Tipo Desino	–	
<b>Daneo DAN 100-45 Ambio (mit Riffel / con scanalatura)</b>	Edelstahl, matt Acciaio inox, opaco	3 1/2" eFlow Desino	–	
		3 1/2" TouchFlow Desino	–	
		3 1/2" Raumspar Desino / Salvaspazio Desino	✓	
		3 1/2" Tipo Desino	–	

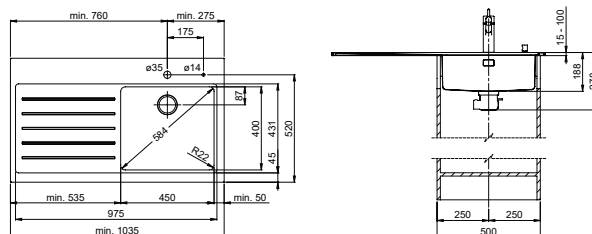

Masse für Variante ohne Riffel identisch.  
Dimensioni identiche per variante senza scanalatura.

 Version Tropfteil links oder rechts erhältlich. Erhältlich für SmartSteel Collection in folgenden Oberflächen:  
Scolatoio disponibile in versione per posizionamento a sinistra o a destra. Disponibile per SmartSteel Collection nelle seguenti finiture:

Standard SF BF WF

 eFlow mit eControl  
eFlow con eControl



 Schwenkbare Überlaufkappe  
Placchetta di troppopieno a ribalta



 Desino: Verdeckter Ablauf mit untenliegendem Korb  
Desino: Scarico coperto con griglietta inferiore



Für eFlow Desino  
Per eFlow Desino



Für TouchFlow Desino, Raumspar Desino und Tipo Desino  
Per TouchFlow Desino, Salvaspazio Desino e Tipo Desino

Für eFlow Desino, TouchFlow Desino, Raumspar Desino und Tipo Desino  
Per eFlow Desino, TouchFlow Desino, Salvaspazio Desino e Tipo Desino

**Ambio**

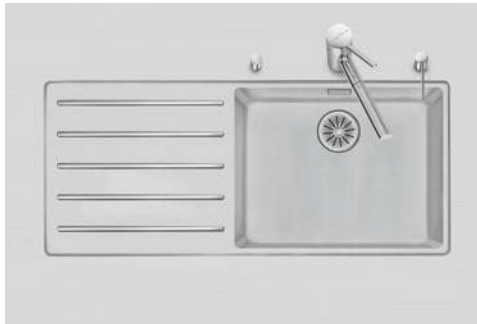
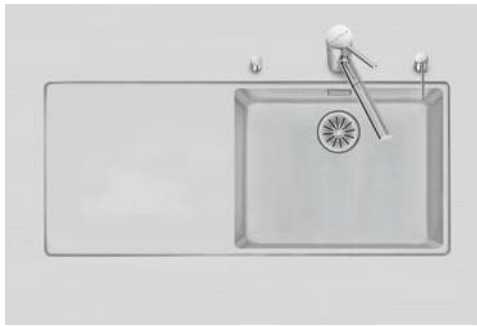
Küchenzubehör ab Seite / Accessori a partire dalla pagina  312



Modell Modello	Material Materiale	Ventil sFlow, Typ S Piletta sFlow, tipo S	 Advant	 in / in cm
<b>Daneo DAN 100-50 EL Ambio</b>	Edelstahl, matt Acciaio inox, opaco	3 1/2" TouchFlow	–	<55>
		3 1/2" Raumspar / Salvaspazio	✓	
		3 1/2" Tipo	–	
<b>Daneo DAN 100-50 Ambio (mit Riffel/ con scanalatura)</b>	Edelstahl, matt Acciaio inox, opaco	3 1/2" TouchFlow	–	
		3 1/2" Raumspar / Salvaspazio	✓	
		3 1/2" Tipo	–	

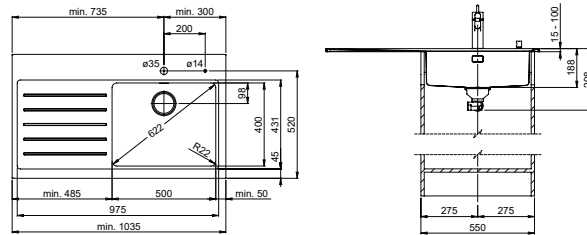



Masse für Variante ohne Riffel identisch.  
Dimensionen identische per variante senza scanalatura.

 Schwenkbare Überlaufkappe  
Placchetta di troppopieno a ribalta

 Version Tropfteil links oder rechts erhältlich. Erhältlich für SmartSteel Collection in folgenden Oberflächen:  
Scolatoio disponibile in versione per posizionamento a sinistra o a destra. Disponibile per SmartSteel Collection nelle seguenti finiture:

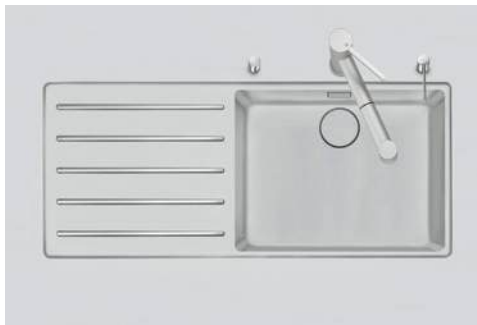
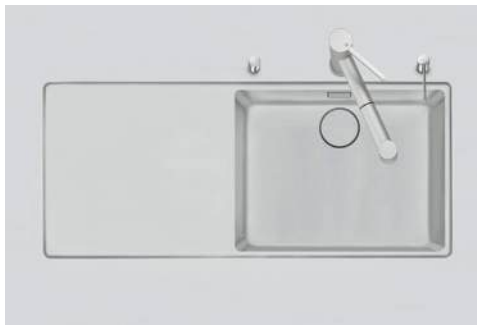
Standard  SF  BF  WF



Modell Modello	Material Materiale	Ventil sFlow, Typ M Piletta sFlow, tipo M	 Advant	 in / in cm
<b>Daneo DAN 100-50 EL Ambio</b>	Edelstahl, matt Acciaio inox, opaco	3 1/2" eFlow Desino	–	<55>
		3 1/2" TouchFlow Desino	–	
		3 1/2" Raumspar Desino / Salvaspazio Desino	✓	
		3 1/2" Tipo Desino	–	
<b>Daneo DAN 100-50 Ambio (mit Riffel/ con scanalatura)</b>	Edelstahl, matt Acciaio inox, opaco	3 1/2" eFlow Desino	–	
		3 1/2" TouchFlow Desino	–	
		3 1/2" Raumspar Desino / Salvaspazio Desino	✓	
		3 1/2" Tipo Desino	–	

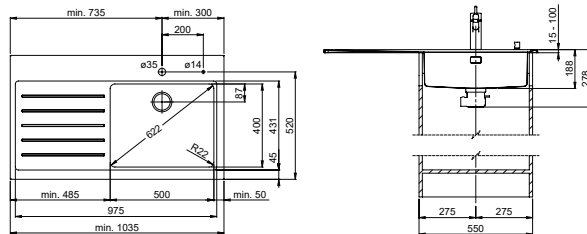

Masse für Variante ohne Riffel identisch.  
Dimensionen identische per variante senza scanalatura.

 Version Tropfteil links oder rechts erhältlich. Erhältlich für SmartSteel Collection in folgenden Oberflächen:  
Scolatoio disponibile in versione per posizionamento a sinistra o a destra. Disponibile per SmartSteel Collection nelle seguenti finiture:

Standard  SF  BF  WF

 eFlow mit eControl  
eFlow con eControl

 13

 Schwenkbare Überlaufkappe  
Placchetta di troppopieno a ribalta

 13

 Desino: Verdeckter Ablauf mit untenliegendem Korb  
Desino: Scarico coperto con griglietta inferiore

 12





Für eFlow Desino  
Per eFlow Desino

Für TouchFlow Desino, Raumspar Desino und Tipo Desino  
Per TouchFlow Desino, Salvaspazio Desino e Tipo Desino

Für eFlow Desino, TouchFlow Desino, Raumspar Desino und Tipo Desino  
Per eFlow Desino, TouchFlow Desino, Salvaspazio Desino e Tipo Desino

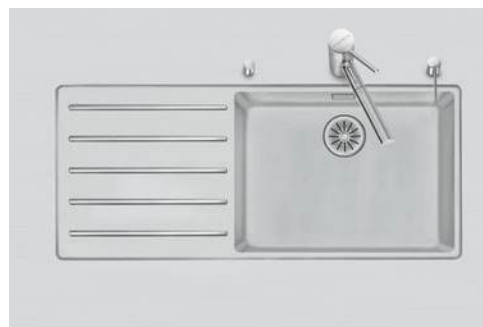
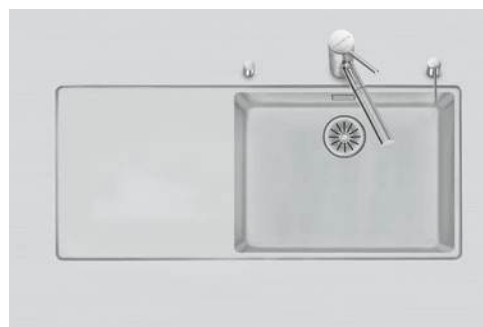
## Ambio

Küchenzubehör ab Seite / Accessori a partire dalla pagina  312

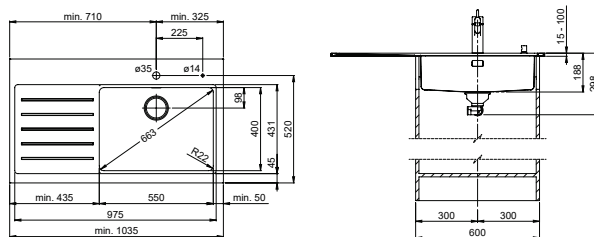

Modell Modello	Material Materiale	Ventil sFlow, Typ S Piletta sFlow, tipo S	 Advant	 in / in cm
<b>Daneo DAN 100-55 EL Ambio</b>	Edelstahl, matt Acciaio inox, opaco	3 1/2" TouchFlow	–	◀60▶
		3 1/2" Raumspar / Salvaspazio	✓	
		3 1/2" Tipo	–	
<b>Daneo DAN 100-55 Ambio (mit Riffel/ con scanalatura)</b>	Edelstahl, matt Acciaio inox, opaco	3 1/2" TouchFlow	–	
		3 1/2" Raumspar / Salvaspazio	✓	
		3 1/2" Tipo	–	





Masse für Variante ohne Riffel identisch.  
Dimensioni identiche per variante senza scanalatura.

 Schwenkbare Überlaufkappe  
Placchetta di troppopieno a ribalta

 Version Tropfteil links oder rechts erhältlich. Erhältlich für SmartSteel Collection in folgenden Oberflächen:  
Scolatoio disponibile in versione per posizionamento a sinistra o a destra. Disponibile per SmartSteel Collection nelle seguenti finiture:

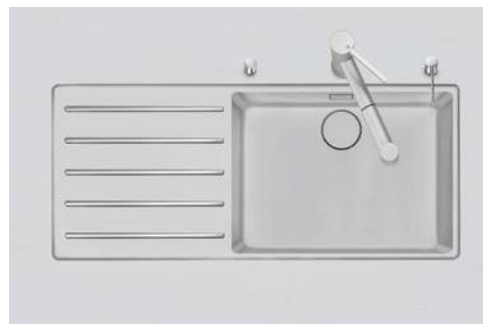
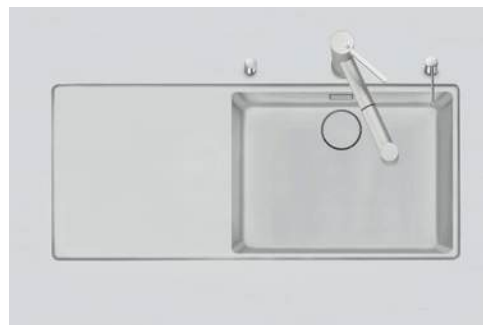
Standard   





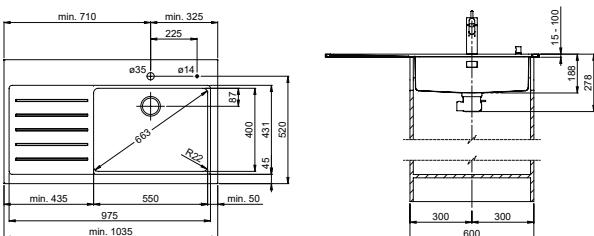

Modell Modello	Material Materiale	Ventil sFlow, Typ M Piletta sFlow, tipo M	 Advant	 in / in cm
<b>Daneo DAN 100-55 EL Ambio</b>	Edelstahl, matt Acciaio inox, opaco	3 1/2" eFlow Desino	–	◀60▶
		3 1/2" TouchFlow Desino	–	
		3 1/2" Raumspar Desino / Salvaspazio Desino	✓	
		3 1/2" Tipo Desino	–	
<b>Daneo DAN 100-55 Ambio (mit Riffel/ con scanalatura)</b>	Edelstahl, matt Acciaio inox, opaco	3 1/2" eFlow Desino	–	
		3 1/2" TouchFlow Desino	–	
		3 1/2" Raumspar Desino / Salvaspazio Desino	✓	
		3 1/2" Tipo Desino	–	



Masse für Variante ohne Riffel identisch.  
Dimensioni identiche per variante senza scanalatura.

 Version Tropfteil links oder rechts erhältlich. Erhältlich für SmartSteel Collection in folgenden Oberflächen:  
Scolatoio disponibile in versione per posizionamento a sinistra o a destra. Disponibile per SmartSteel Collection nelle seguenti finiture:

Standard   

 eFlow mit eControl  
eFlow con eControl

 13

 Schwenkbare Überlaufkappe  
Placchetta di troppopieno a ribalta

 13

 Desino: Verdeckter Ablauf mit untenliegendem Korb  
Desino: Scarico coperto con griglietta inferiore

 12



Für eFlow Desino  
Per eFlow Desino



Für TouchFlow Desino, Raumspar Desino und Tipo Desino  
Per TouchFlow Desino, Salvaspazio Desino e Tipo Desino

Für eFlow Desino, TouchFlow Desino, Raumspar Desino und Tipo Desino  
Per eFlow Desino, TouchFlow Desino, Salvaspazio Desino e Tipo Desino

Classic

Küchenzubehör ab Seite / Accessori a partire dalla pagina  312



Modell Modello	Material Materiale	Ventil sFlow, Typ S Piletta sFlow, tipo S	 Prime	 in / in cm
<b>Vantis V 90-45 EL Classic</b>	Edelstahl, matt Acciaio inox, opaco	3 1/2" TouchFlow	–	<50>
		3 1/2" Raumspar / Salvaspazio	✓	
		3 1/2" Tipo	–	
<b>Vantis V 90-45 Classic (mit Riffel / con scanalatura)</b>	Edelstahl, matt Acciaio inox, opaco	3 1/2" TouchFlow	–	
		3 1/2" Raumspar / Salvaspazio	✓	
		3 1/2" Tipo	–	

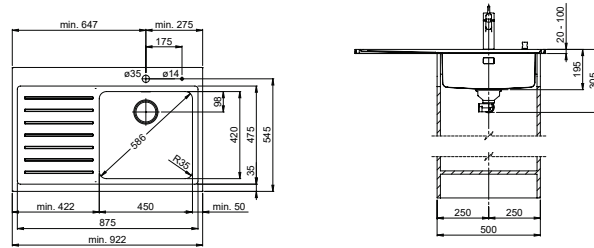



Masse für Variante ohne Riffel identisch.  
Dimensioni identiche per variante senza scanalatura.

 Schwenkbare Überlaufkappe  
Placchetta di troppopieno a ribalta

 Version Tropfteil links oder rechts erhältlich. Erhältlich für SmartSteel Collection in folgenden Oberflächen:  
Scolatoio disponibile in versione per posizionamento a sinistra o a destra. Disponibile per SmartSteel Collection nelle seguenti finiture:

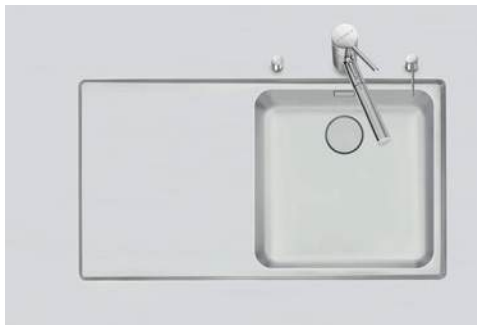
Standard SF BF BX WF



Modell Modello	Material Materiale	Ventil sFlow, Typ M Piletta sFlow, tipo M	 Advant	 in / in cm
<b>Vantis V 90-45 EL Classic</b>	Edelstahl, matt Acciaio inox, opaco	3 1/2" eFlow Desino	–	<50>
		3 1/2" TouchFlow Desino	–	
		3 1/2" Raumspar Desino / Salvaspazio Desino	✓	
		3 1/2" Tipo Desino	–	
<b>Vantis V 90-45 Classic (mit Riffel / con scanalatura)</b>	Edelstahl, matt Acciaio inox, opaco	3 1/2" eFlow Desino	–	
		3 1/2" TouchFlow Desino	–	
		3 1/2" Raumspar Desino / Salvaspazio Desino	✓	

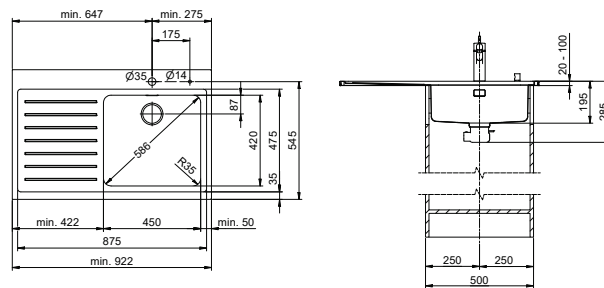

Masse für Variante ohne Riffel identisch.  
Dimensioni identiche per variante senza scanalatura.

 Version Tropfteil links oder rechts erhältlich. Erhältlich für SmartSteel Collection in folgenden Oberflächen:  
Scolatoio disponibile in versione per posizionamento a sinistra o a destra. Disponibile per SmartSteel Collection nelle seguenti finiture:

Standard SF BF WF

 eFlow mit eControl  
eFlow con eControl

 13

 Schwenkbare Überlaufkappe  
Placchetta di troppopieno a ribalta

 13

 Desino: Verdeckter Ablauf mit untenliegendem Korb  
Desino: Scarico coperto con griglietta inferiore

 12



Für eFlow Desino  
Per eFlow Desino

Für TouchFlow Desino, Raumspar Desino und Tipo Desino  
Per TouchFlow Desino, Salvaspazio Desino e Tipo Desino

Für eFlow Desino, TouchFlow Desino, Raumspar Desino und Tipo Desino  
Per eFlow Desino, TouchFlow Desino, Salvaspazio Desino e Tipo Desino

## Classic

Küchenzubehör ab Seite / Accessori a partire dalla pagina 312



Modell Modello	Material Materiale	Ventil sFlow, Typ S Piletta sFlow, tipo S	Prime	in / in cm
<b>Vantis V 100-40 EL Classic</b>	Edelstahl, matt Acciaio inox, opaco	3 1/2" TouchFlow	–	◀45▶
		3 1/2" Raumspar / Salvaspazio	✓	
		3 1/2" Tipo	–	
<b>Vantis V 100-40 Classic (mit Riffel / con scanalatura)</b>	Edelstahl, matt Acciaio inox, opaco	3 1/2" TouchFlow	–	
		3 1/2" Raumspar / Salvaspazio	✓	
		3 1/2" Tipo	–	

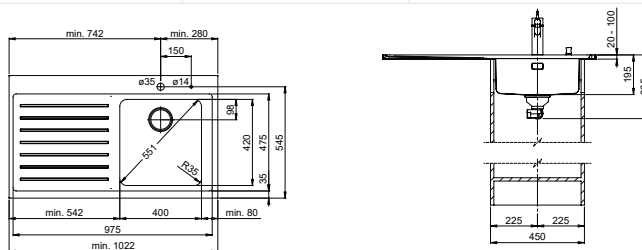

Masse für Variante ohne Riffel identisch.  
Dimensioni identiche per variante senza scanalatura.

Schwenkbare Überlaufkappe  
Placchetta di troppopieno a ribalta

Version Tropfteil links oder rechts erhältlich. Erhältlich für SmartSteel Collection in folgenden Oberflächen:

Scolatoio disponibile in versione per posizionamento a sinistra o a destra. Disponibile per SmartSteel Collection nelle seguenti finiture:

Standard SF BF BX WF

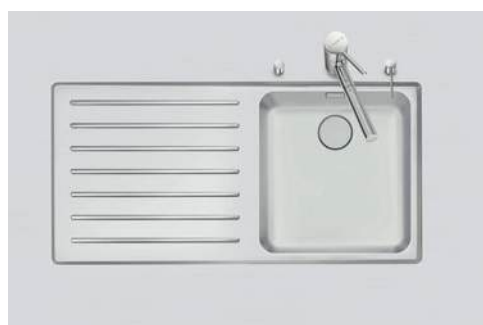

Modell Modello	Material Materiale	Ventil sFlow, Typ M Piletta sFlow, tipo M	Advant	in / in cm
<b>Vantis V 100-40 EL Classic</b>	Edelstahl, matt Acciaio inox, opaco	3 1/2" eFlow Desino	–	◀45▶
		3 1/2" TouchFlow Desino	–	
		3 1/2" Raumspar Desino / Salvaspazio Desino	✓	
		3 1/2" Tipo Desino	–	
<b>Vantis V 100-40 Classic (mit Riffel / con scanalatura)</b>	Edelstahl, matt Acciaio inox, opaco	3 1/2" eFlow Desino	–	
		3 1/2" TouchFlow Desino	–	
		3 1/2" Raumspar Desino / Salvaspazio Desino	✓	
		3 1/2" Tipo Desino	–	

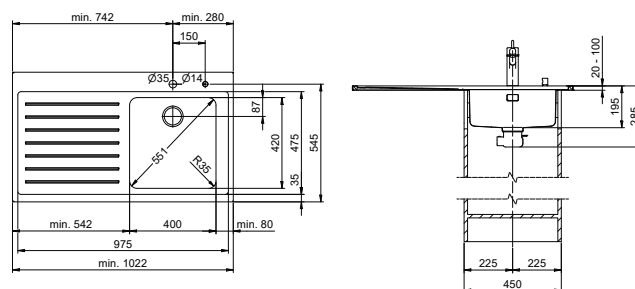

Masse für Variante ohne Riffel identisch.  
Dimensioni identiche per variante senza scanalatura.

Version Tropfteil links oder rechts erhältlich. Erhältlich für SmartSteel Collection in folgenden Oberflächen:

Scolatoio disponibile in versione per posizionamento a sinistra o a destra. Disponibile per SmartSteel Collection nelle seguenti finiture:

Standard SF BF WF

eFlow mit eControl  
eFlow con eControl

13

Schwenkbare Überlaufkappe  
Placchetta di troppopieno a ribalta

13

Desino: Verdeckter Ablauf mit untenliegendem Korb  
Desino: Scarico coperto con griglietta inferiore

12



Für eFlow Desino  
Per eFlow Desino



Für TouchFlow Desino, Raumspar Desino und Tipo Desino  
Per TouchFlow Desino, Salvaspazio Desino e Tipo Desino

Für eFlow Desino, TouchFlow Desino, Raumspar Desino und Tipo Desino  
Per eFlow Desino, TouchFlow Desino, Salvaspazio Desino e Tipo Desino

Classic

Küchenzubehör ab Seite / Accessori a partire dalla pagina  312



Modell Modello	Material Materiale	Ventil sFlow, Typ S Piletta sFlow, tipo S	 Prime	 in / in cm
<b>Vantis V 100-45 EL Classic</b>	Edelstahl, matt Acciaio inox, opaco	3 1/2" TouchFlow	–	◀50▶
		3 1/2" Raumspar / Salvaspazio	✓	
		3 1/2" Tipo	–	
<b>Vantis V 100-45 Classic (mit Riffel / con scanalatura)</b>	Edelstahl, matt Acciaio inox, opaco	3 1/2" TouchFlow	–	
		3 1/2" Raumspar / Salvaspazio	✓	
		3 1/2" Tipo	–	

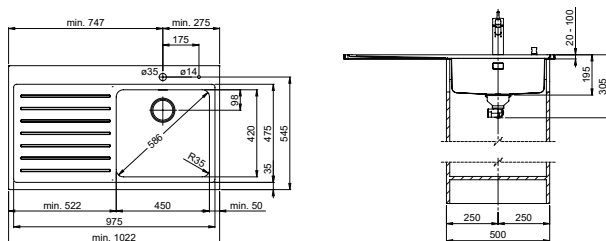



Masse für Variante ohne Riffel identisch.  
Dimensioni identiche per variante senza scanalatura.

 Schwenkbare Überlaufkappe  
Placchetta di troppopieno a ribalta

 Version Tropfteil links oder rechts erhältlich. Erhältlich für SmartSteel Collection in folgenden Oberflächen:  
Scolatoio disponibile in versione per posizionamento a sinistra o a destra. Disponibile per SmartSteel Collection nelle seguenti finiture:

Standard SF BF BX WF



Modell Modello	Material Materiale	Ventil sFlow, Typ M Piletta sFlow, tipo M	 Advant	 in / in cm
<b>Vantis V 100-45 EL Classic</b>	Edelstahl, matt Acciaio inox, opaco	3 1/2" eFlow Desino	–	◀50▶
		3 1/2" TouchFlow Desino	–	
		3 1/2" Raumspar Desino / Salvaspazio Desino	✓	
		3 1/2" Tipo Desino	–	
<b>Vantis V 100-45 Classic (mit Riffel / con scanalatura)</b>	Edelstahl, matt Acciaio inox, opaco	3 1/2" eFlow Desino	–	
		3 1/2" TouchFlow Desino	–	
		3 1/2" Raumspar Desino / Salvaspazio Desino	✓	
		3 1/2" Tipo Desino	–	

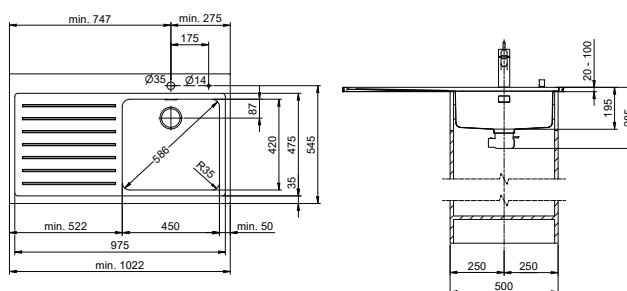

Masse für Variante ohne Riffel identisch.  
Dimensioni identiche per variante senza scanalatura.

 Version Tropfteil links oder rechts erhältlich. Erhältlich für SmartSteel Collection in folgenden Oberflächen:  
Scolatoio disponibile in versione per posizionamento a sinistra o a destra. Disponibile per SmartSteel Collection nelle seguenti finiture:

Standard SF BF WF

 eFlow mit eControl  
eFlow con eControl

 13

 Schwenkbare Überlaufkappe  
Placchetta di troppopieno a ribalta

 13

 Desino: Verdeckter Ablauf mit untenliegendem Korb  
Desino: Scarico coperto con griglietta inferiore

 12



Für eFlow Desino  
Per eFlow Desino





Für TouchFlow Desino, Raumspar Desino und Tipo Desino  
Per TouchFlow Desino, Salvaspazio Desino e Tipo Desino



Für eFlow Desino, TouchFlow Desino, Raumspar Desino und Tipo Desino  
Per eFlow Desino, TouchFlow Desino, Salvaspazio Desino e Tipo Desino

## Classic

Küchenzubehör ab Seite / Accessori a partire dalla pagina  312

Modell Modello	Material Materiale	Ventil sFlow, Typ S Piletta sFlow, tipo S	 Prime	 in / in cm
<b>Vantis V 100-50 EL Classic</b>	Edelstahl, matt Acciaio inox, opaco	3 1/2" TouchFlow	–	◀55▶
		3 1/2" Raumspar / Salvaspazio	✓	
		3 1/2" Tipo	–	
<b>Vantis V 100-50 Classic (mit Riffel / con scanalatura)</b>	Edelstahl, matt Acciaio inox, opaco	3 1/2" TouchFlow	–	
		3 1/2" Raumspar / Salvaspazio	✓	
		3 1/2" Tipo	–	

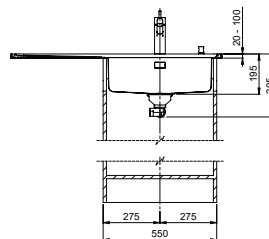
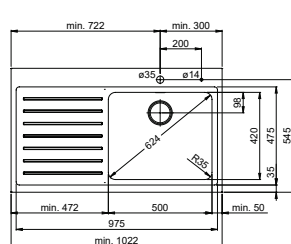

Masse für Variante ohne Riffel identisch.  
Dimensioni identiche per variante senza scanalatura.



 Schwenkbare Überlaufkappe  
Placchetta di troppopieno a ribalta

 Version Tropfteil links oder rechts erhältlich. Erhältlich für SmartSteel Collection in folgenden Oberflächen:

Scolatoio disponibile in versione per posizionamento a sinistra o a destra. Disponibile per SmartSteel Collection nelle seguenti finiture:

Standard SF BF BX WF



Modell Modello	Material Materiale	Ventil sFlow, Typ M Piletta sFlow, tipo M	 Advant	 in / in cm
<b>Vantis V 100-50 EL Classic</b>	Edelstahl, matt Acciaio inox, opaco	3 1/2" eFlow Desino	–	◀55▶
		3 1/2" TouchFlow Desino	–	
		3 1/2" Raumspar Desino / Salvaspazio Desino	✓	
		3 1/2" Tipo Desino	–	
<b>Vantis V 100-50 Classic (mit Riffel / con scanalatura)</b>	Edelstahl, matt Acciaio inox, opaco	3 1/2" eFlow Desino	–	
		3 1/2" TouchFlow Desino	–	
		3 1/2" Raumspar Desino / Salvaspazio Desino	✓	
		3 1/2" Tipo Desino	–	

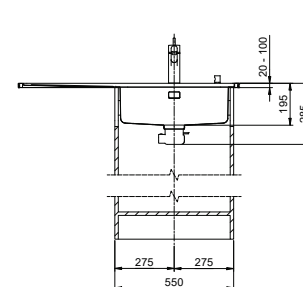
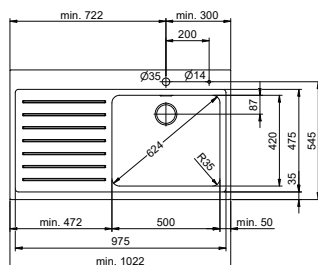

 Version Tropfteil links oder rechts erhältlich. Erhältlich für SmartSteel Collection in folgenden Oberflächen:

Scolatoio disponibile in versione per posizionamento a sinistra o a destra. Disponibile per SmartSteel Collection nelle seguenti finiture:

Standard SF BF WF

 eFlow mit eControl  
eFlow con eControl



 Schwenkbare Überlaufkappe  
Placchetta di troppopieno a ribalta



 Desino: Verdeckter Ablauf mit untenliegendem Korb  
Desino: Scarico coperto con griglietta inferiore



Für eFlow Desino  
Per eFlow Desino

Für TouchFlow Desino, Raumspar Desino und Tipo Desino  
Per TouchFlow Desino, Salvaspazio Desino e Tipo Desino

Für eFlow Desino, TouchFlow Desino, Raumspar Desino und Tipo Desino  
Per eFlow Desino, TouchFlow Desino, Salvaspazio Desino e Tipo Desino

Classic

Küchenzubehör ab Seite / Accessori a partire dalla pagina 312



Modell Modello	Material Materiale	Ventil sFlow, Typ S Piletta sFlow, tipo S	Prime	in / in cm
<b>Vantis V 100-55 EL Classic</b>	Edelstahl, matt Acciaio inox, opaco	3 1/2" TouchFlow	-	◀60▶
		3 1/2" Raumspar / Salvaspazio	✓	
		3 1/2" Tipo	-	
<b>Vantis V 100-55 Classic (mit Riffel / con scanalatura)</b>	Edelstahl, matt Acciaio inox, opaco	3 1/2" TouchFlow	-	
		3 1/2" Raumspar / Salvaspazio	✓	
		3 1/2" Tipo	-	

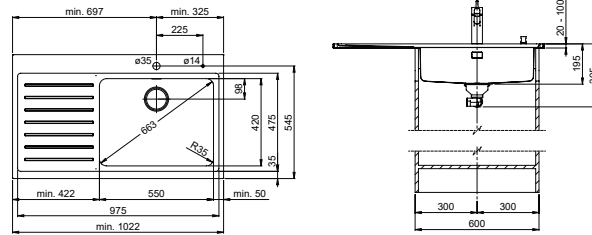

Masse für Variante ohne Riffel identisch.  
Dimensioni identiche per variante senza scanalatura.

Schwenkbare Überlaufkappe  
Placchetta di troppopieno a ribalta

Version Tropfteil links oder rechts erhältlich. Erhältlich für SmartSteel Collection in folgenden Oberflächen:  
Scolatoio disponibile in versione per posizionamento a sinistra o a destra. Disponibile per SmartSteel Collection nelle seguenti finiture:

Standard SF BF BX WF

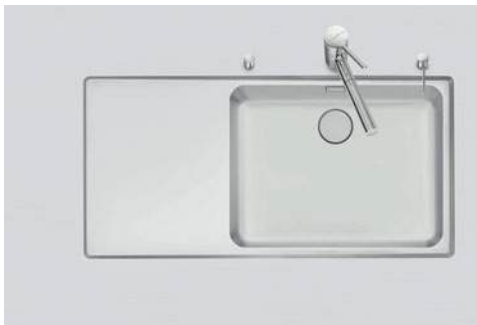

Modell Modello	Material Materiale	Ventil sFlow, Typ M Piletta sFlow, tipo M	Advant	in / in cm
<b>Vantis V 100-55 EL Classic</b>	Edelstahl, matt Acciaio inox, opaco	3 1/2" eFlow Desino	-	◀60▶
		3 1/2" TouchFlow Desino	-	
		3 1/2" Raumspar Desino / Salvaspazio Desino	✓	
		3 1/2" Tipo Desino	-	
<b>Vantis V 100-55 Classic (mit Riffel / con scanalatura)</b>	Edelstahl, matt Acciaio inox, opaco	3 1/2" eFlow Desino	-	
		3 1/2" TouchFlow Desino	-	
		3 1/2" Raumspar Desino / Salvaspazio Desino	✓	
		3 1/2" Tipo Desino	-	

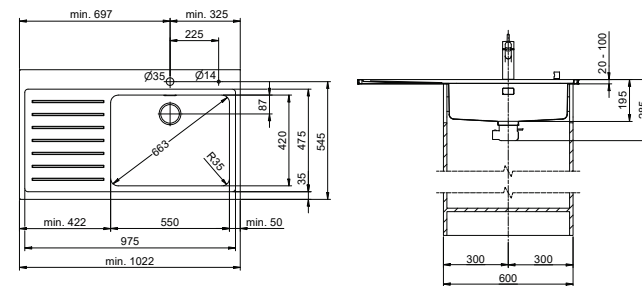

Masse für Variante ohne Riffel identisch.  
Dimensioni identiche per variante senza scanalatura.

Version Tropfteil links oder rechts erhältlich. Erhältlich für SmartSteel Collection in folgenden Oberflächen:  
Scolatoio disponibile in versione per posizionamento a sinistra o a destra. Disponibile per SmartSteel Collection nelle seguenti finiture:

Standard SF BF WF

eFlow mit eControl  
eFlow con eControl

13

Schwenkbare Überlaufkappe  
Placchetta di troppopieno a ribalta

13

Desino: Verdeckter Ablauf mit untenliegendem Korb  
Desino: Scarico coperto con griglietta inferiore

12



Für eFlow Desino  
Per eFlow Desino

Für TouchFlow Desino, Raumspar Desino und Tipo Desino  
Per TouchFlow Desino, Salvaspazio Desino e Tipo Desino

Für eFlow Desino, TouchFlow Desino, Raumspar Desino und Tipo Desino  
Per eFlow Desino, TouchFlow Desino, Salvaspazio Desino e Tipo Desino

## Classic

Küchenzubehör ab Seite / Accessori a partire dalla pagina 312



Modell Modello	Material Materiale	Ventil sFlow, Typ S Piletta sFlow, tipo S	Advant	in / in cm
<b>Vantis VG 90-45 Green EL Classic</b>	Edelstahl, matt Acciaio inox, opaco	3 1/2" TouchFlow	–	◀50▶
		3 1/2" Raumspar / Salvaspazio	✓	
		3 1/2" Tipo	–	
<b>Vantis VG 90-45 Green Classic (mit Riffel / con scanalatura)</b>	Edelstahl, matt Acciaio inox, opaco	3 1/2" TouchFlow	–	
		3 1/2" Raumspar / Salvaspazio	✓	
		3 1/2" Tipo	–	

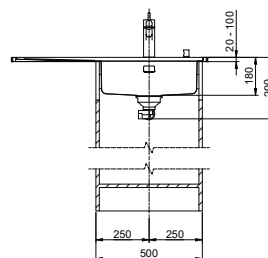
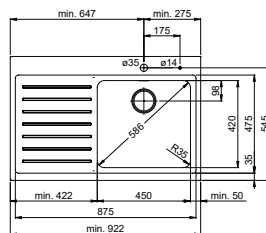

Masse für Variante ohne Riffel identisch.  
Dimensioni identiche per variante senza scanalatura.

**GREEN LINE** Green Line ist eine eigenständige auf Nachhaltigkeit ausgerichtete Produktausführung. Green Line è una versione di prodotto autonoma calibrata sulla sostenibilità.

Schwenkbare Überlaufkappe  
Placchetta di troppopieno a ribalta

Version Tropfteil links oder rechts erhältlich.  
Scolatoio disponibile in versione per posizionamento a sinistra o a destra.



Modell Modello	Material Materiale	Ventil sFlow, Typ S Piletta sFlow, tipo S	Advant	in / in cm
<b>Vantis VG 100-45 Green EL Classic</b>	Edelstahl, matt Acciaio inox, opaco	3 1/2" TouchFlow	–	◀50▶
		3 1/2" Raumspar / Salvaspazio	✓	
		3 1/2" Tipo	–	
<b>Vantis VG 100-45 Green Classic (mit Riffel / con scanalatura)</b>	Edelstahl, matt Acciaio inox, opaco	3 1/2" TouchFlow	–	
		3 1/2" Raumspar / Salvaspazio	✓	
		3 1/2" Tipo	–	

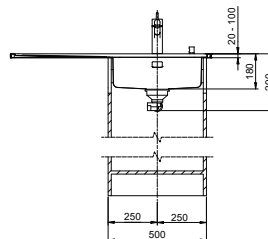
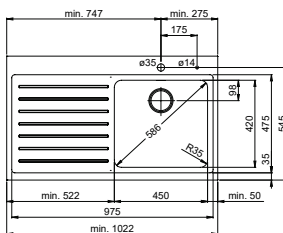

Masse für Variante ohne Riffel identisch.  
Dimensioni identiche per variante senza scanalatura.

**GREEN LINE** Green Line ist eine eigenständige auf Nachhaltigkeit ausgerichtete Produktausführung. Green Line è una versione di prodotto autonoma calibrata sulla sostenibilità.

Schwenkbare Überlaufkappe  
Placchetta di troppopieno a ribalta

Version Tropfteil links oder rechts erhältlich.  
Scolatoio disponibile in versione per posizionamento a sinistra o a destra.

## Standardoberflächen / Superfici standard

SF	Seidenmatt-Finish / Finitura satinata
BF	Breitband-Finish / Finitura a nastro largo
BX	Breitband Varix / Nastro largo Varix
WF	Wirbel-Finish / Finitura a turbino

## Decor Oberflächen / Superfici Decor

PS	Polaris Silver
PB	Polaris Black
TR	Terra

## Spezialoberflächen / Superfici speciali

ID	IceDesign	PL	Polar Look
BI	BlackRange Industrial	XI	Xrange Ice
BP	BlackRange Passion	XF	Xrange Fineline

XB	Xrange Black
SL	Silk Look
WG	Warmgewalzt Laminazione a caldo

## Ausführung / Lavorazione

**GREEN LINE** Green Line

Alle Massangaben in mm  
Unità di misura in mm

Classic

Küchenzubehör ab Seite / Accessori a partire dalla pagina 312



Modell Modello	Material Materiale	Ventil sFlow, Typ S Piletta sFlow, tipo S	Advant	in / in cm
<b>Vantis VG 100-50 Green EL Classic</b>	Edelstahl, matt Acciaio inox, opaco	3 1/2" TouchFlow	–	◀55▶
		3 1/2" Raumspar / Salvaspazio	✓	
		3 1/2" Tipo	–	
<b>Vantis VG 100-50 Green Classic (mit Riffel / con scanalatura)</b>	Edelstahl, matt Acciaio inox, opaco	3 1/2" TouchFlow	–	
		3 1/2" Raumspar / Salvaspazio	✓	
		3 1/2" Tipo	–	

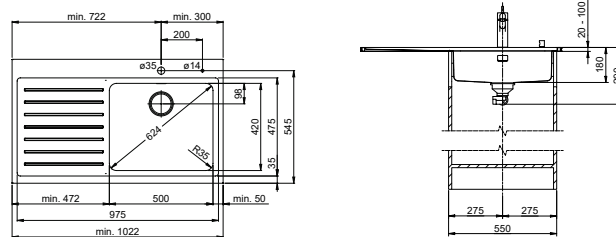

**GREEN LINE** Green Line ist eine eigenständige auf Nachhaltigkeit ausgerichtete Produktausführung. Green Line è una versione di prodotto autonoma calibrata sulla sostenibilità.

Masse für Variante ohne Riffel identisch.  
Dimensioni identiche per variante senza scanalatura.

Schwenkbare Überlaufkappe  
Placchetta di troppopieno a ribalta

Version Tropfteil links oder rechts erhältlich.  
Scolatoio disponibile in versione per posizionamento a sinistra o a destra.



Modell Modello	Material Materiale	Ventil sFlow, Typ S Piletta sFlow, tipo S	Advant	in / in cm
<b>Vantis VG 100-55 Green EL Classic</b>	Edelstahl, matt Acciaio inox, opaco	3 1/2" TouchFlow	–	◀60▶
		3 1/2" Raumspar / Salvaspazio	✓	
		3 1/2" Tipo	–	
<b>Vantis VG 100-55 Green Classic (mit Riffel / con scanalatura)</b>	Edelstahl, matt Acciaio inox, opaco	3 1/2" TouchFlow	–	
		3 1/2" Raumspar / Salvaspazio	✓	
		3 1/2" Tipo	–	

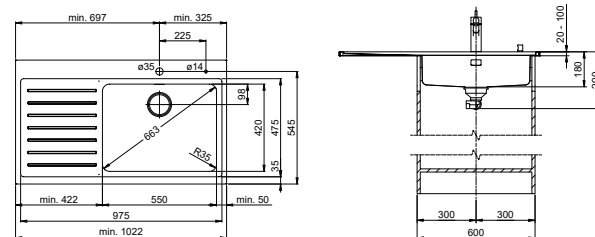

**GREEN LINE** Green Line ist eine eigenständige auf Nachhaltigkeit ausgerichtete Produktausführung. Green Line è una versione di prodotto autonoma calibrata sulla sostenibilità.

Masse für Variante ohne Riffel identisch.  
Dimensioni identiche per variante senza scanalatura.

Schwenkbare Überlaufkappe  
Placchetta di troppopieno a ribalta

Version Tropfteil links oder rechts erhältlich.  
Scolatoio disponibile in versione per posizionamento a sinistra o a destra.

Standardoberflächen / Superfici standard

SF	Seidenmatt-Finish / Finitura satinata
BF	Breitband-Finish / Finitura a nastro largo
BX	Breitband Varix / Nastro largo Varix
WF	Wirbel-Finish / Finitura a turbino

Decor Oberflächen / Superfici Decor

PS	Polaris Silver
PB	Polaris Black
TR	Terra

Spezialoberflächen / Superfici speciali

ID	IceDesign	PL	Polar Look	XB	Xrange Black
BI	BlackRange Industrial	XI	Xrange Ice	SL	Silk Look
BP	BlackRange Passion	XF	Xrange Finline	WG	Warmgewalzt Laminazione a caldo

Ausführung / Lavorazione

Green Line

Alle Massangaben in mm  
Unità di misura in mm

## Classic

Küchenzubehör ab Seite / Accessori a partire dalla pagina  312

Modell Modello	Material Materiale	Ventil Piletta	 Prime	 in / in cm
<b>Vantis VX 90-45 EL Varix Classic</b>	Edelstahl, mid-matt Acciaio inox, mid-matt	3 1/2" Raumspar / Salvaspazio	✓	◀50▶
		3 1/2" Siebstopfen / A tappo c. griglietta	–	
<b>Vantis VX 90-45 Varix Classic (mit Riffel/ con scanalatura)</b>	Edelstahl, mid-matt Acciaio inox, mid-matt	3 1/2" Raumspar / Salvaspazio	✓	
		3 1/2" Siebstopfen / A tappo c. griglietta	–	

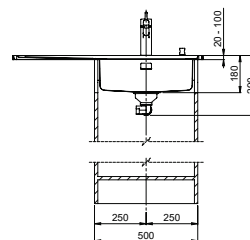
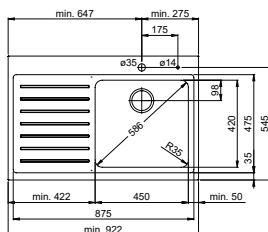

Masse für Variante ohne Riffel identisch.  
Dimensioni identiche per variante senza scanalatura.

 Version Tropfteil links oder rechts erhältlich. Erhältlich für SmartSteel Collection in folgenden Oberflächen:

Scolatoio disponibile in versione per posizionamento a sinistra o a destra. Disponibile per SmartSteel Collection nelle seguenti finiture:

Standard

SF BF BX WF

## Standardoberflächen / Superfici standard

SF	Seidenmatt-Finish / Finitura satinata
BF	Breitband-Finish / Finitura a nastro largo
BX	Breitband Varix / Nastro largo Varix
WF	Wirbel-Finish / Finitura a turbinio

## Decor Oberflächen / Superfici Decor

PS	Polaris Silver
PB	Polaris Black
TR	Terra

## Spezialoberflächen / Superfici speciali

ID	IceDesign	PL	Polar Look
BI	BlackRange Industrial	XI	Xrange Ice
BP	BlackRange Passion	XF	Xrange Finline

XB	Xrange Black
SL	Silk Look
WG	Warmgewalzt Laminazione a caldo

## Ausführung / Lavorazione

 Green Line

Alle Massangaben in mm  
Unità di misura in mm

Classic

Küchenzubehör ab Seite / Accessori a partire dalla pagina 312



Modell Modello	Material Materiale	Ventil Piletta	Prime	in / in cm
<b>Vantis VX 100-40 EL Varix Classic</b>	Edelstahl, mid-matt	3 1/2" Raumspar / Salvaspazio	✓	◀45▶
	Acciaio inox, mid-matt	3 1/2" Siebstopfen / A tappo c. griglietta	–	
<b>Vantis VX 100-40 Varix Classic (mit Riffel/ con scanalatura)</b>	Edelstahl, mid-matt	3 1/2" Raumspar / Salvaspazio	✓	
	Acciaio inox, mid-matt	3 1/2" Siebstopfen / A tappo c. griglietta	–	

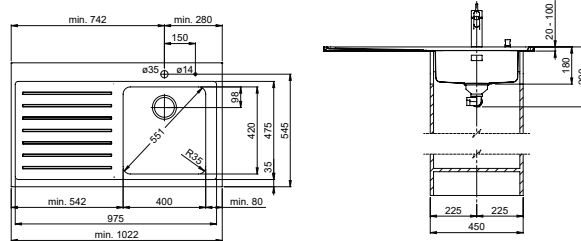

Masse für Variante ohne Riffel identisch.  
Dimensioni identiche per variante senza scanalatura.

Standard SF BF BX WF

**i** Version Tropfteil links oder rechts erhältlich. Erhältlich für SmartSteel Collection in folgenden Oberflächen:  
Scolatoio disponibile in versione per posizionamento a sinistra o a destra. Disponibile per SmartSteel Collection nelle seguenti finiture:



Modell Modello	Material Materiale	Ventil Piletta	Prime	in / in cm
<b>Vantis VX 100-45 EL Varix Classic</b>	Edelstahl, mid-matt	3 1/2" Raumspar / Salvaspazio	✓	◀50▶
	Acciaio inox, mid-matt	3 1/2" Siebstopfen / A tappo c. griglietta	–	
<b>Vantis VX 100-45 Varix Classic (mit Riffel/ con scanalatura)</b>	Edelstahl, mid-matt	3 1/2" Raumspar / Salvaspazio	✓	
	Acciaio inox, mid-matt	3 1/2" Siebstopfen / A tappo c. griglietta	–	

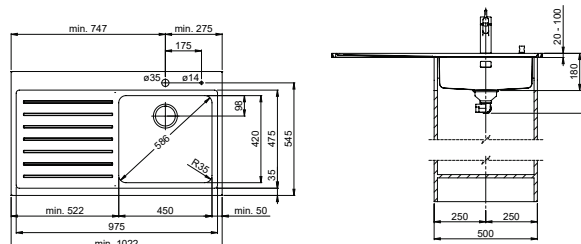

Masse für Variante ohne Riffel identisch.  
Dimensioni identiche per variante senza scanalatura.

Standard SF BF BX WF

**i** Version Tropfteil links oder rechts erhältlich. Erhältlich für SmartSteel Collection in folgenden Oberflächen:  
Scolatoio disponibile in versione per posizionamento a sinistra o a destra. Disponibile per SmartSteel Collection nelle seguenti finiture:

Standardoberflächen / Superfici standard

SF	Seidenmatt-Finish / Finitura satinata
BF	Breitband-Finish / Finitura a nastro largo
BX	Breitband Varix / Nastro largo Varix
WF	Wirbel-Finish / Finitura a turbinio

Decor Oberflächen / Superfici Decor

PS	Polaris Silver
PB	Polaris Black
TR	Terra

Spezialoberflächen / Superfici speciali

ID	IceDesign	PL	Polar Look
BI	BlackRange Industrial	XI	Xrange Ice
BP	BlackRange Passion	XF	Xrange Fineline

XB	Xrange Black
SL	Silk Look
WG	Warmgewalzt Laminazione a caldo

Ausführung / Lavorazione

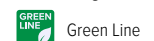

Alle Massangaben in mm  
Unità di misura in mm

## Classic

Küchenzubehör ab Seite / Accessori a partire dalla pagina 312



Modell Modello	Material Materiale	Ventil Piletta	Prime	in / in cm
<b>Vantis VX 100-50 EL Varix Classic</b>	Edelstahl, mid-matt	3 1/2" Raumspar / Salvaspazio	✓	◀55▶
	Acciaio inox, mid-matt	3 1/2" Siebstopfen / A tappo c. griglietta	-	
<b>Vantis VX 100-50 Varix Classic (mit Riffel/ con scanalatura)</b>	Edelstahl, mid-matt	3 1/2" Raumspar / Salvaspazio	✓	
	Acciaio inox, mid-matt	3 1/2" Siebstopfen / A tappo c. griglietta	-	

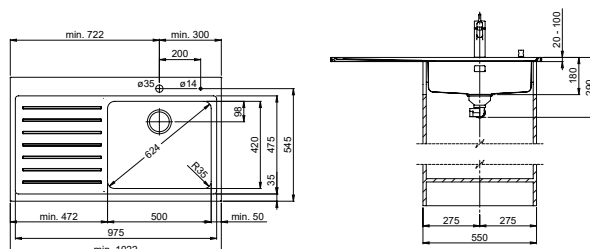

Masse für Variante ohne Riffel identisch.  
Dimensioni identiche per variante senza scanalatura.

Standard SF BF BX WF

**i** Version Tropfteil links oder rechts erhältlich. Erhältlich für SmartSteel Collection in folgenden Oberflächen:

Scolatoio disponibile in versione per posizionamento a sinistra o a destra. Disponibile per SmartSteel Collection nelle seguenti finiture:



Modell Modello	Material Materiale	Ventil Piletta	Prime	in / in cm
<b>Vantis VX 100-55 EL Varix Classic</b>	Edelstahl, mid-matt	3 1/2" Raumspar / Salvaspazio	✓	◀60▶
	Acciaio inox, mid-matt	3 1/2" Siebstopfen / A tappo c. griglietta	-	
<b>Vantis VX 100-55 Varix Classic (mit Riffel/ con scanalatura)</b>	Edelstahl, mid-matt	3 1/2" Raumspar / Salvaspazio	✓	
	Acciaio inox, mid-matt	3 1/2" Siebstopfen / A tappo c. griglietta	-	

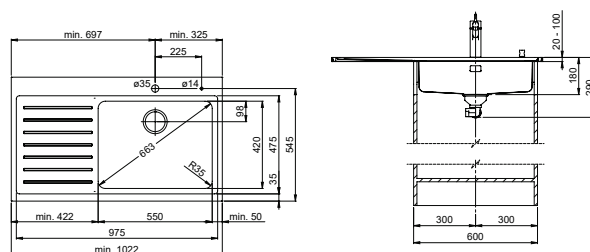

Masse für Variante ohne Riffel identisch.  
Dimensioni identiche per variante senza scanalatura.

Standard SF BF BX WF

**i** Version Tropfteil links oder rechts erhältlich. Erhältlich für SmartSteel Collection in folgenden Oberflächen:

Scolatoio disponibile in versione per posizionamento a sinistra o a destra. Disponibile per SmartSteel Collection nelle seguenti finiture:

## Standardoberflächen / Superfici standard

SF	Seidenmatt-Finish / Finitura satinata
BF	Breitband-Finish / Finitura a nastro largo
BX	Breitband Varix / Nastro largo Varix
WF	Wirbel-Finish / Finitura a turbini

## Decor Oberflächen / Superfici Decor

PS	Polaris Silver
PB	Polaris Black
TR	Terra

## Spezialoberflächen / Superfici speciali

ID	IceDesign	PL	Polar Look
BI	BlackRange Industrial	XI	Xrange Ice
BP	BlackRange Passion	XF	Xrange Finline

XB	Xrange Black
SL	Silk Look
WG	Warmgewalzt Laminazione a caldo

## Ausführung / Lavorazione

Green Line

Alle Massangaben in mm  
Unità di misura in mm

Classic

Küchenzubehör ab Seite / Accessori a partire dalla pagina 312



Modell Modello	Material Materiale	Ventil Piletta	Prime	in / in cm
<b>Silver Star SIL 90-45 EL Classic</b>	Edelstahl, matt Acciaio inox, opaco	3 1/2" Raumspar / Salvaspazio	✓	◀50▶
		3 1/2" Tipo	–	
	Edelstahl, glanz Acciaio inox, lucido	3 1/2" Raumspar / Salvaspazio	✓	
		3 1/2" Tipo	–	
<b>Silver Star SIL 90-45 Classic (mit Riffel/ con scanalatura)</b>	Edelstahl, matt Acciaio inox, opaco	3 1/2" Raumspar / Salvaspazio	✓	
		3 1/2" Tipo	–	
	Edelstahl, glanz Acciaio inox, lucido	3 1/2" Raumspar / Salvaspazio	✓	
		3 1/2" Tipo	–	

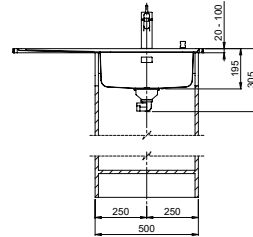
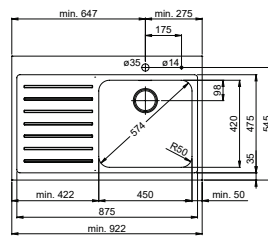

**i** Version Tropfteil links oder rechts erhältlich. Erhältlich für SmartSteel Collection in folgenden Oberflächen:  
Scolatoio disponibile in versione per posizionamento a sinistra o a destra. Disponibile per SmartSteel Collection nelle seguenti finiture:

Standard **SF** **BF** **BX** **WF**



Modell Modello	Material Materiale	Ventil Piletta	Prime	in / in cm
<b>Silver Star SIL 100-18/34 EL Classic</b>	Edelstahl, matt Acciaio inox, opaco	3 1/2" Raumspar / Salvaspazio	✓	◀60▶
		3 1/2" Tipo	–	
	Edelstahl, glanz Acciaio inox, lucido	3 1/2" Raumspar / Salvaspazio	✓	
		3 1/2" Tipo	–	
<b>Silver Star SIL 100-18/34 Classic (mit Riffel/ con scanalatura)</b>	Edelstahl, matt Acciaio inox, opaco	3 1/2" Raumspar / Salvaspazio	✓	
		3 1/2" Tipo	–	
	Edelstahl, glanz Acciaio inox, lucido	3 1/2" Raumspar / Salvaspazio	✓	
		3 1/2" Tipo	–	

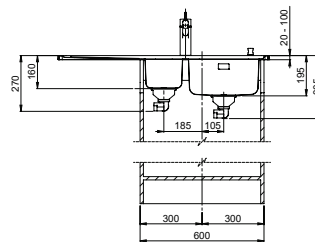
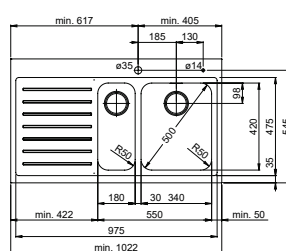

**i** Version Tropfteil links oder rechts erhältlich. Erhältlich für SmartSteel Collection in folgenden Oberflächen:  
Scolatoio disponibile in versione per posizionamento a sinistra o a destra. Disponibile per SmartSteel Collection nelle seguenti finiture:

Standard **SF** **BF** **BX** **WF**

Standardoberflächen / Superfici standard

SF	Seidenmatt-Finish / Finitura satinata
BF	Breitband-Finish / Finitura a nastro largo
BX	Breitband Varix / Nastro largo Varix
WF	Wirbel-Finish / Finitura a turbino

Decor Oberflächen / Superfici Decor

PS	Polaris Silver
PB	Polaris Black
TR	Terra

Spezialoberflächen / Superfici speciali

ID	IceDesign	PL	Polar Look	XB	Xrange Black
BI	BlackRange Industrial	XI	Xrange Ice	SL	Silk Look
BP	BlackRange Passion	XF	Xrange Finline	WG	Warmgewalzt Laminazione a caldo

Ausführung / Lavorazione

Green Line

Alle Massangaben in mm  
Unità di misura in mm

## Classic

Küchenzubehör ab Seite / Accessori a partire dalla pagina 312



Modell Modello	Material Materiale	Ventil Piletta	Prime	in / in cm
<b>Silver Star SIL 100-45 EL Classic</b>	Edelstahl, matt Acciaio inox, opaco	3 1/2" Raumspar / Salvaspazio	✓	450 ▶
		3 1/2" Tipo	–	
	Edelstahl, glanz Acciaio inox, lucido	3 1/2" Raumspar / Salvaspazio	✓	
		3 1/2" Tipo	–	
<b>Silver Star SIL 100-45 Classic (mit Riffel/ con scanalatura)</b>	Edelstahl, matt Acciaio inox, opaco	3 1/2" Raumspar / Salvaspazio	✓	
		3 1/2" Tipo	–	
	Edelstahl, glanz Acciaio inox, lucido	3 1/2" Raumspar / Salvaspazio	✓	
		3 1/2" Tipo	–	

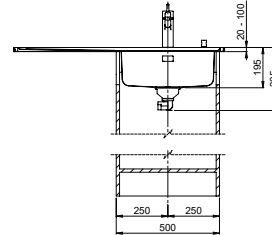
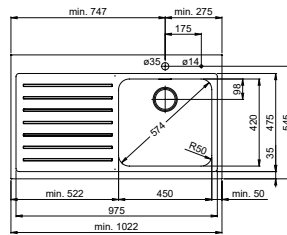

**i** Version Tropfteil links oder rechts erhältlich. Erhältlich für SmartSteel Collection in folgenden Oberflächen:

Scolatoio disponibile in versione per posizionamento a sinistra o a destra. Disponibile per SmartSteel Collection nelle seguenti finiture:

Standard **SF** **BF** **BX** **WF**

Masse für Variante ohne Riffel identisch.  
Dimensioni identiche per variante senza scanalatura.



Modell Modello	Material Materiale	Ventil Piletta	Prime	in / in cm
<b>Silver Star SIS 100-50 EL Classic</b>	Edelstahl, matt Acciaio inox, opaco	3 1/2" Raumspar / Salvaspazio	✓	450 ▶
		3 1/2" Tipo	–	
	Edelstahl, glanz Acciaio inox, lucido	3 1/2" Raumspar / Salvaspazio	✓	
		3 1/2" Tipo	–	
<b>Silver Star SIS 100-50 Classic (mit Riffel/ con scanalatura)</b>	Edelstahl, matt Acciaio inox, opaco	3 1/2" Raumspar / Salvaspazio	✓	
		3 1/2" Tipo	–	
	Edelstahl, glanz Acciaio inox, lucido	3 1/2" Raumspar / Salvaspazio	✓	
		3 1/2" Tipo	–	

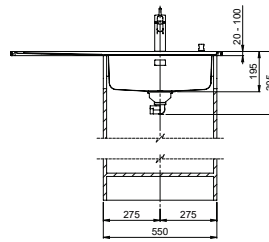
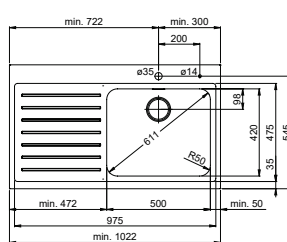

**i** Version Tropfteil links oder rechts erhältlich. Erhältlich für SmartSteel Collection in folgenden Oberflächen:

Scolatoio disponibile in versione per posizionamento a sinistra o a destra. Disponibile per SmartSteel Collection nelle seguenti finiture:

Standard **SF** **BF** **BX** **WF**

Masse für Variante ohne Riffel identisch.  
Dimensioni identiche per variante senza scanalatura.

## Standardoberflächen / Superfici standard

SF	Seidenmatt-Finish / Finitura satinata
BF	Breitband-Finish / Finitura a nastro largo
BX	Breitband Varix / Nastro largo Varix
WF	Wirbel-Finish / Finitura a turbino

## Decor Oberflächen / Superfici Decor

PS	Polaris Silver
PB	Polaris Black
TR	Terra

## Spezialoberflächen / Superfici speciali

ID	IceDesign	PL	Polar Look
BI	BlackRange Industrial	XI	Xrange Ice
BP	BlackRange Passion	XF	Xrange Fineline

XB	Xrange Black
SL	Silk Look
WG	Warmgewalzt Laminazione a caldo

## Ausführung / Lavorazione

**GREEN LINE** Green Line

Alle Massangaben in mm  
Unità di misura in mm

Classic

Küchenzubehör ab Seite / Accessori a partire dalla pagina 312



Modell Modello	Material Materiale	Ventil Piletta	Prime	in / in cm
<b>Silver Star SIL 100-55 EL Classic</b>	Edelstahl, matt Acciaio inox, opaco	3 1/2" Raumspar / Salvaspazio	✓	60
		3 1/2" Tipo	–	
	Edelstahl, glanz Acciaio inox, lucido	3 1/2" Raumspar / Salvaspazio	✓	
		3 1/2" Tipo	–	
<b>Silver Star SIL 100-55 Classic (mit Riffel/ con scanalatura)</b>	Edelstahl, matt Acciaio inox, opaco	3 1/2" Raumspar / Salvaspazio	✓	
		3 1/2" Tipo	–	
	Edelstahl, glanz Acciaio inox, lucido	3 1/2" Raumspar / Salvaspazio	✓	
		3 1/2" Tipo	–	

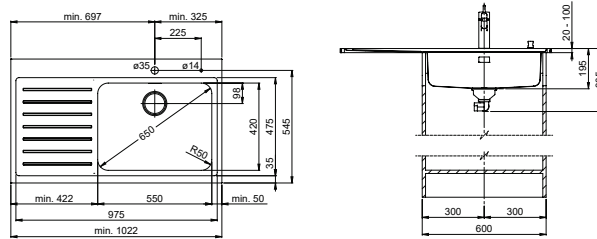

**i** Version Tropfteil links oder rechts erhältlich. Erhältlich für SmartSteel Collection in folgenden Oberflächen:  
Scolatoio disponibile in versione per posizionamento a sinistra o a destra. Disponibile per SmartSteel Collection nelle seguenti finiture:

- Standard SF BF BX WF

Masse für Variante ohne Riffel identisch.  
Dimensioni identiche per variante senza scanalatura.

Massanfertigungen  
Soluzioni a misura

Standardoberflächen / Superfici standard

- SF Seidenmatt-Finish / Finitura satinata
- BF Breitband-Finish / Finitura a nastro largo
- BX Breitband Varix / Nastro largo Varix
- WF Wirbel-Finish / Finitura a turbino

Decor Oberflächen / Superfici Decor

- PS Polaris Silver
- PB Polaris Black
- TR Terra

Spezialoberflächen / Superfici speciali

- ID IceDesign
- BI BlackRange Industrial
- BP BlackRange Passion
- PL Polar Look
- XI Xrange Ice
- XF Xrange Fineline

- XB Xrange Black
- SL Silk Look
- WG Warmgewalzt  
Laminazione a caldo

Ausführung / Lavorazione

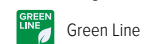

Alle Massangaben in mm  
Unità di misura in mm

## Classic

Küchenzubehör ab Seite / Accessori a partire dalla pagina 312



Modell Modello	Material Materiale	Ventil Piletta	Prime	in / in cm
<b>Silver Star SX 100-40 EL Varix Classic</b>	Edelstahl, mid-matt Eco Acciaio inox, mid-matt Eco	3 1/2" Raumspar / Salvaspazio	✓	45
		3 1/2" Siebstopfen / A tappo c. griglietta	–	
<b>Silver Star SX 100-40 Varix Classic (mit Riffel/ con scanalatura)</b>	Edelstahl, mid-matt Eco Acciaio inox, mid-matt Eco	3 1/2" Raumspar / Salvaspazio	✓	
		3 1/2" Siebstopfen / A tappo c. griglietta	–	

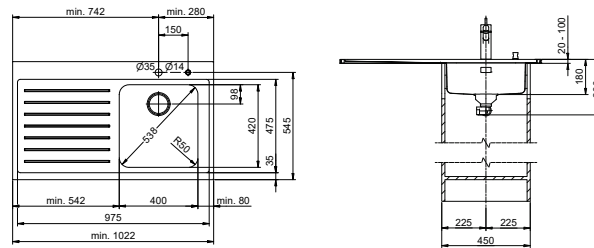

**i** Version Tropfteil links oder rechts erhältlich. Erhältlich für SmartSteel Collection in folgenden Oberflächen:

Scolatoio disponibile in versione per posizionamento a sinistra o a destra. Disponibile per SmartSteel Collection nelle seguenti finiture:

Standard **SF** **BF** **BX** **WF**

Masse für Variante ohne Riffel identisch.  
Dimensioni identiche per variante senza scanalatura.



Modell Modello	Material Materiale	Ventil Piletta	Prime	in / in cm
<b>Silver Star SX 100-50 EL Varix Classic</b>	Edelstahl, mid-matt Eco Acciaio inox, mid-matt Eco	3 1/2" Raumspar / Salvaspazio	✓	55
		3 1/2" Siebstopfen / A tappo c. griglietta	–	
<b>Silver Star SX 100-50 Varix Classic (mit Riffel/ con scanalatura)</b>	Edelstahl, mid-matt Eco Acciaio inox, mid-matt Eco	3 1/2" Raumspar / Salvaspazio	✓	
		3 1/2" Siebstopfen / A tappo c. griglietta	–	

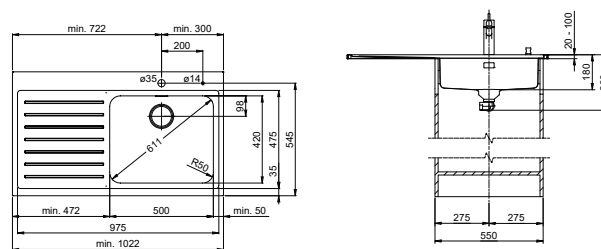

**i** Version Tropfteil links oder rechts erhältlich. Erhältlich für SmartSteel Collection in folgenden Oberflächen:

Scolatoio disponibile in versione per posizionamento a sinistra o a destra. Disponibile per SmartSteel Collection nelle seguenti finiture:

Standard **SF** **BF** **BX** **WF**

Masse für Variante ohne Riffel identisch.  
Dimensioni identiche per variante senza scanalatura.

## Standardoberflächen / Superfici standard

SF	Seidenmatt-Finish / Finitura satinata
BF	Breitband-Finish / Finitura a nastro largo
BX	Breitband Varix / Nastro largo Varix
WF	Wirbel-Finish / Finitura a turbino

## Decor Oberflächen / Superfici Decor

PS	Polaris Silver
PB	Polaris Black
TR	Terra

## Spezialoberflächen / Superfici speciali

ID	IceDesign	PL	Polar Look	XB	Xrange Black
BI	BlackRange Industrial	XI	Xrange Ice		
BP	BlackRange Passion	XF	Xrange Fineline		

## Ausführung / Lavorazione

**GREEN LINE** Green Line

SL	Silk Look
WG	Warmgewalzt Laminazione a caldo

Alle Massangaben in mm  
Unità di misura in mm

Comfort

Küchenzubehör ab Seite / Accessori a partire dalla pagina  312



**i** Version Tropfteil links oder rechts erhältlich. Erhältlich für SmartSteel Collection in folgenden Oberflächen:  
Scolatoio disponibile in versione per posizionamento a sinistra o a destra. Disponibile per SmartSteel Collection nelle seguenti finiture:

Standard SF BF BX WF

Modell Modello	Material Materiale	Ventil Piletta	 Prime	 in / in cm
<b>Comfort COM 75</b>	Edelstahl, glanz Acciaio inox, lucido	3 1/2" Raumspar / Salvaspazio	✓	440
		3 1/2" Tipo	–	
		1 1/2" Standrohr / Con tubo	–	

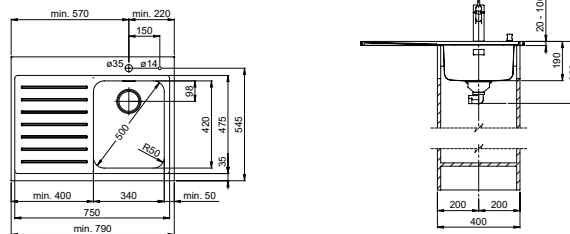



**i** Version Tropfteil links oder rechts erhältlich. Erhältlich für SmartSteel Collection in folgenden Oberflächen:  
Scolatoio disponibile in versione per posizionamento a sinistra o a destra. Disponibile per SmartSteel Collection nelle seguenti finiture:

Standard SF BF BX WF

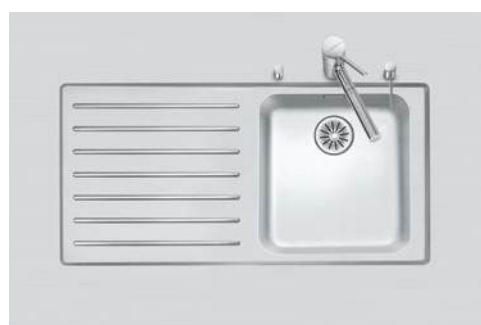
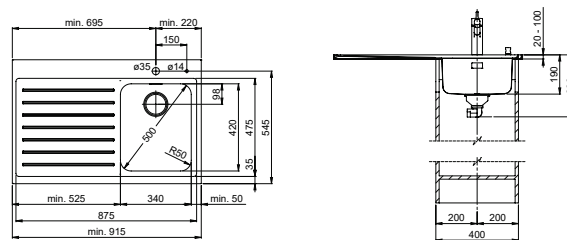
Modell Modello	Material Materiale	Ventil Piletta	 Prime	 in / in cm
<b>Comfort COM 90</b>	Edelstahl, glanz Acciaio inox, lucido	3 1/2" Raumspar / Salvaspazio	✓	440
		3 1/2" Tipo	–	
		1 1/2" Standrohr / Con tubo	–	



Modell Modello	Material Materiale	Ventil Piletta	 Prime	 in / in cm
<b>Comfort COM 100-40 EL</b>	Edelstahl, glanz Acciaio inox, lucido	3 1/2" Raumspar / Salvaspazio	✓	45
		3 1/2" Tipo	–	
<b>Comfort COM 100-40 (mit Riffel / con scanalatura)</b>	Edelstahl, glanz Acciaio inox, lucido	3 1/2" Raumspar / Salvaspazio	✓	
		3 1/2" Tipo	–	

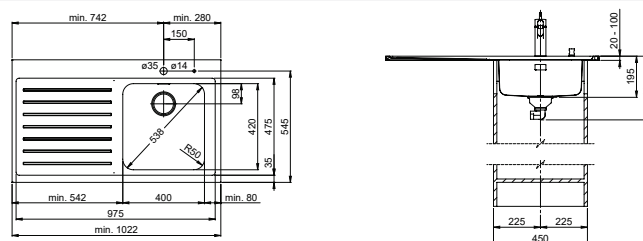

Masse für Variante ohne Riffel identisch.  
Dimensioni identiche per variante senza scanalatura.

**i** Version Tropfteil links oder rechts erhältlich. Erhältlich für SmartSteel Collection in folgenden Oberflächen:  
Scolatoio disponibile in versione per posizionamento a sinistra o a destra. Disponibile per SmartSteel Collection nelle seguenti finiture:

Standard SF BF BX WF

## Comfort

Küchenzubehör ab Seite / Accessori a partire dalla pagina 312



**i** Version Tropfteil links oder rechts erhältlich. Erhältlich für SmartSteel Collection in folgenden Oberflächen:  
Scolatoio disponibile in versione per posizionamento a sinistra o a destra. Disponibile per SmartSteel Collection nelle seguenti finiture:

Standard **SF** **BF** **WF**

Modell Modello	Material Materiale	Ventil Piletta	Prime	in / in cm
<b>Comfort COM 135-34</b>	Edelstahl, glanz Acciaio inox, lucido	3 1/2" Raumspar / Salvaspazio	✓	◀80▶
		3 1/2" Tipo	–	

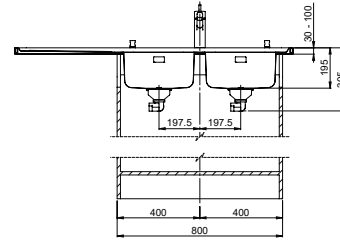
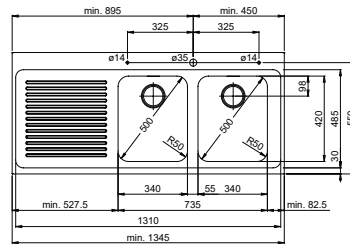

**i** Version Tropfteil links oder rechts erhältlich. Erhältlich für SmartSteel Collection in folgenden Oberflächen:  
Scolatoio disponibile in versione per posizionamento a sinistra o a destra. Disponibile per SmartSteel Collection nelle seguenti finiture:

Standard **SF** **BF** **WF**

Modell Modello	Material Materiale	Ventil Piletta	Prime	in / in cm
<b>Comfort COM 135-40</b>	Edelstahl, glanz Acciaio inox, lucido	3 1/2" Raumspar / Salvaspazio	✓	◀90▶
		3 1/2" Tipo	–	

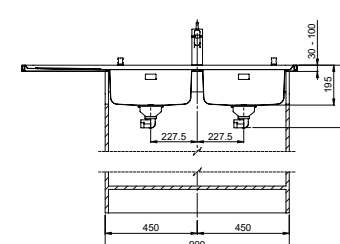
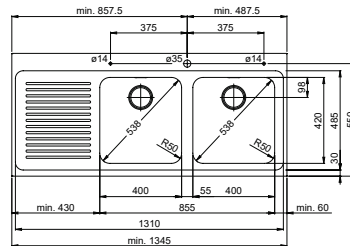

## Standardoberflächen / Superfici standard

SF	Seidenmatt-Finish / Finitura satinata
BF	Breitband-Finish / Finitura a nastro largo
BX	Breitband Varix / Nastro largo Varix
WF	Wirbel-Finish / Finitura a turbini

## Decor Oberflächen / Superfici Decor

PS	Polaris Silver
PB	Polaris Black
TR	Terra

## Spezialoberflächen / Superfici speciali

ID	IceDesign
BI	BlackRange Industrial
BP	BlackRange Passion
PL	Polar Look
XI	Xrange Ice
XF	Xrange Fineline

XB	Xrange Black
SL	Silk Look
WG	Warmgewalzt Laminazione a caldo

## Ausführung / Lavorazione

Green Line

Alle Massangaben in mm  
Unità di misura in mm

# Manufaktur Tropfteile / Scolatoi di manifattura

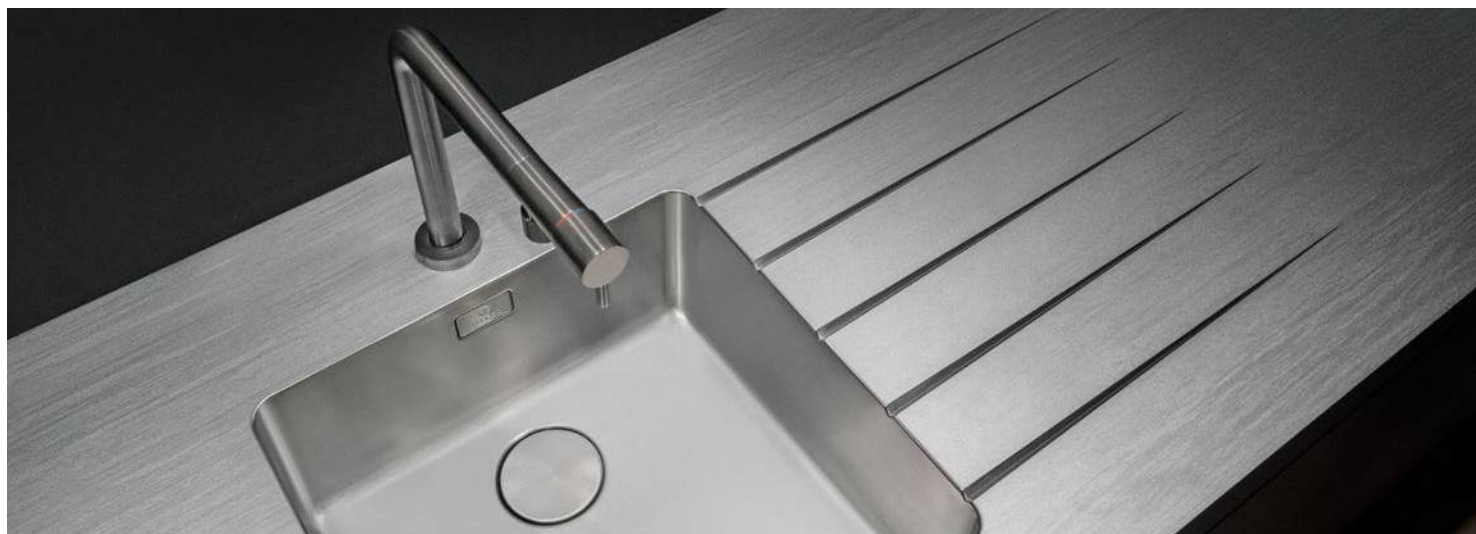

Massanfertigungen  
Soluzioni a misura

## Canyon / Canyon

Küchenzubehör ab Seite / Accessori a partire dalla pagina 312



### Erhältliche Ausführung / Lavorazione disponibile

SmartSteel Collection  SolidSteel Collection

### Erhältliche Oberflächen / Superfici disponibili

Standard  BF  WF  
Spezial  ID  BI  BP  PL  SL  WG

Weitere Produktinformationen / Altre informazioni prodotto 20+22

**i** Für Kantenhöhe 8 mm erhältlich. Rillen werden max. 5 mm glänzend eingefräst.  
Disponibile per bordo con altezza 8 mm. Scanalatura max 5 mm con fresatura lucida.

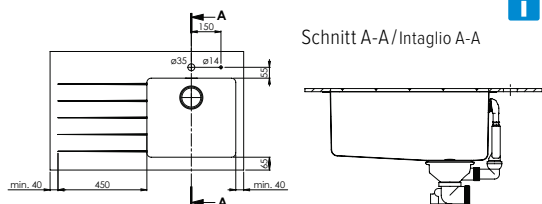

### Standardoberflächen / Superfici standard

SF	Seidenmatt-Finish / Finitura satinata
BF	Breitband-Finish / Finitura a nastro largo
BX	Breitband Varix / Nastro largo Varix
WF	Wirbel-Finish / Finitura a turbino

### Decor Oberflächen / Superfici Decor

PS	Polaris Silver
PB	Polaris Black
TR	Terra

### Spezialoberflächen / Superfici speciali

ID	IceDesign	PL	Polar Look
BI	BlackRange Industrial	XI	Xrange Ice
BP	BlackRange Passion	XF	Xrange Finline

XB	Xrange Black
SL	Silk Look
WG	Warmgewalzt Laminazione a caldo

### Ausführung / Lavorazione



Alle Massangaben in mm  
Unità di misura in mm

## Evo Manufaktur Tropfteil/ Scolatoi di manifattura Evo

Küchenzubehör ab Seite / Accessori a partire dalla pagina 312

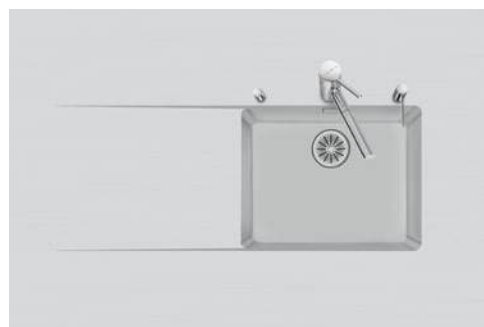

**i** Version Tropfteil links oder rechts erhältlich. Erhältlich für SmartSteel Collection in folgenden Oberflächen:  
Scolatoio disponibile in versione per posizionamento a sinistra o a destra. Disponibile per SmartSteel Collection nelle seguenti finiture:

Standard **SF** **BF** **WF**

Modell Modello	Material Materiale	Ventil sFlow, Typ S Piletta sFlow, tipo S	Advant	in / in cm
Daneo DAN 50 Evo	Edelstahl, matt Acciaio inox, opaco	3 1/2" TouchFlow	–	◀55▶
		3 1/2" Raumspar / Salvaspazio	✓	
		3 1/2" Tipo	–	

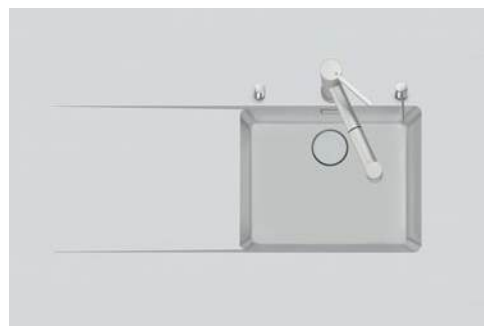
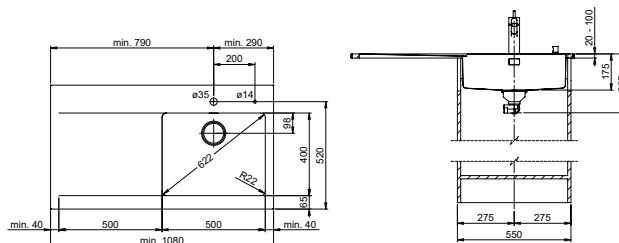

**i** Version Tropfteil links oder rechts erhältlich. Erhältlich für SmartSteel Collection in folgenden Oberflächen:  
Scolatoio disponibile in versione per posizionamento a sinistra o a destra. Disponibile per SmartSteel Collection nelle seguenti finiture:

Standard **SF** **BF** **WF**

Modell Modello	Material Materiale	Ventil sFlow, Typ M Piletta sFlow, tipo M	Advant	in / in cm
Daneo DAN 50 Evo	Edelstahl, matt Acciaio inox, opaco	3 1/2" eFlow Desino	–	◀55▶
		3 1/2" TouchFlow Desino	–	
		3 1/2" Raumspar Desino / Salvaspazio Desino	✓	
		3 1/2" Tipo Desino	–	

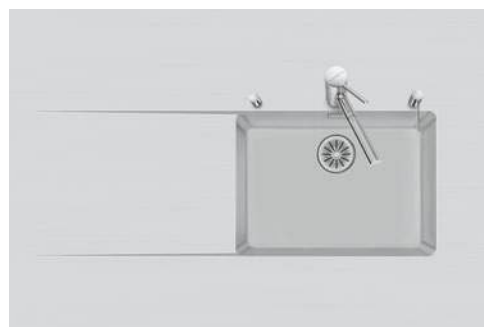
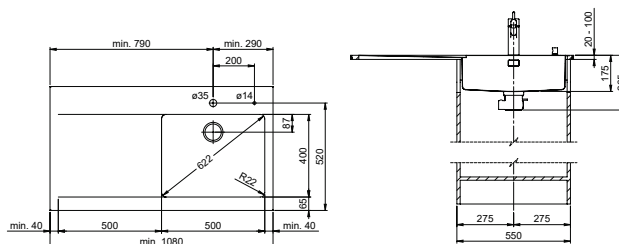

**i** Schwenkbare Überlaufkappe  
Placchetta di troppieno a ribalta

**i** Version Tropfteil links oder rechts erhältlich. Erhältlich für SmartSteel Collection in folgenden Oberflächen:  
Scolatoio disponibile in versione per posizionamento a sinistra o a destra. Disponibile per SmartSteel Collection nelle seguenti finiture:

Standard **SF** **BF** **WF**

Modell Modello	Material Materiale	Ventil sFlow, Typ S Piletta sFlow, tipo S	Advant	in / in cm
Daneo DAN 55 Evo	Edelstahl, matt Acciaio inox, opaco	3 1/2" TouchFlow	–	◀60▶
		3 1/2" Raumspar / Salvaspazio	✓	
		3 1/2" Tipo	–	

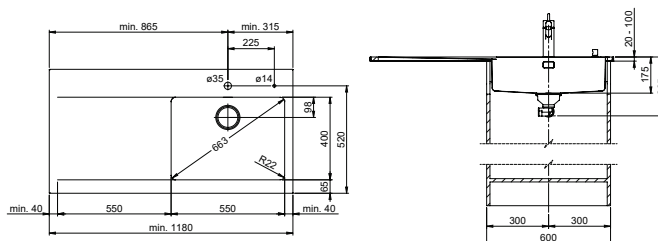

Evo Manufaktur Tropfteil / Scolatoi di manifattura Evo

Küchenzubehör ab Seite / Accessori a partire dalla pagina 312

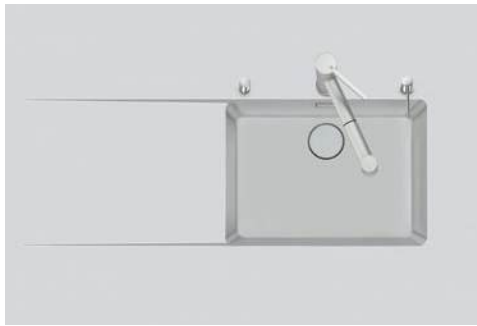

Modell Modello	Material Materiale	Ventil sFlow, Typ M Piletta sFlow, tipo M	Advant	in / in cm
Daneo DAN 55 Evo	Edelstahl, matt Acciaio inox, opaco	3 1/2" eFlow Desino	–	◀60▶
		3 1/2" TouchFlow Desino	–	
		3 1/2" Raumspar Desino / Salvaspazio Desino	✓	
		3 1/2" Tipo Desino	–	

**i** Version Tropfteil links oder rechts erhältlich. Erhältlich für SmartSteel Collection in folgenden Oberflächen:  
Scolatoio disponibile in versione per posizionamento a sinistra o a destra. Disponibile per SmartSteel Collection nelle seguenti finiture:

Standard **SF** **BF** **WF**

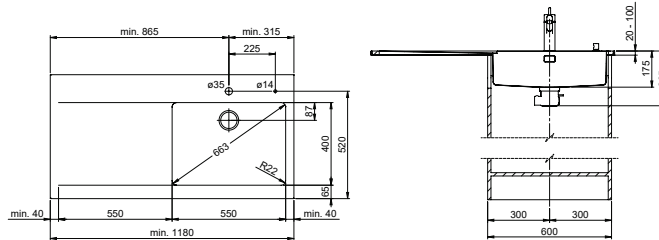

Gleitbahn / Scivolo

Küchenzubehör ab Seite / Accessori a partire dalla pagina 312



Erhältliche Ausführung / Lavorazione disponibile

SmartSteel Collection  SolidSteel Collection

Erhältliche Oberflächen / Superfici disponibili

Standard **BF** **WF**

Weitere Produktinformationen / Altre informazioni prodotto 20



**i** Für Kantenhöhe A20 – A100 erhältlich. Mit Gefälle einseitig, zweiseitig oder ohne Gefälle möglich. Beckentyp und -position frei wählbar. Kein einlaufender Anschluss an Gewerbespüle.  
Disponibile per altezze di bordo A20 – A100. Possibile con pendenza su un lato, su due lati o senza pendenza. Libera scelta di modello e posizione del lavello. Nessun attacco diretto a lavastoviglie industriali.

Minimalmasse / Misure minime

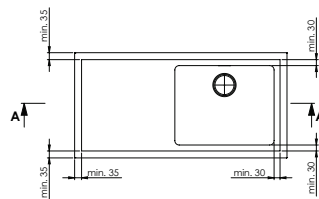

Schnitt A-A / Intaglio A-A

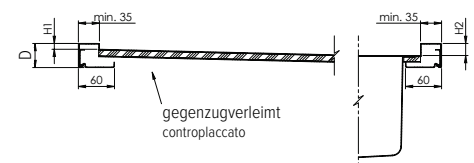

Kantenhöhe (D) Altezze di bordo (D)	A30	A40
H1	min. 12 / max. 15	min. 12 / max. 20
H2	max. 25	max. 30

Standardoberflächen / Superfici standard

SF	Seidenmatt-Finish / Finitura satinata
BF	Breitband-Finish / Finitura a nastro largo
BX	Breitband Varix / Nastro largo Varix
WF	Wirbel-Finish / Finitura a turbino

Decor Oberflächen / Superfici Decor

PS	Polaris Silver
PB	Polaris Black
TR	Terra

Spezialoberflächen / Superfici speciali

ID	IceDesign	PL	Polar Look	XB	Xrange Black
BI	BlackRange Industrial	XI	Xrange Ice	SL	Silk Look
BP	BlackRange Passion	XF	Xrange Finline	WG	Warmgewalzt Laminazione a caldo

Ausführung / Lavorazione

**GREEN LINE** Green Line

Alle Massangaben in mm  
Unità di misura in mm



**Sortiment nach Unterschrankmassen**

Assortimento per dimensioni di base **130**

**Edelstahl/Acciaio inox**

**Linero**

LIO 18U + LIO 34U	<b>132-133</b>
LIO 40U	<b>134-135</b>
LIO 45U	<b>136-137</b>
LIO 50U	<b>138-139</b>
LIO 55U	<b>140-141</b>

**Daneo**

DAN 18U + DAN 34U	<b>142-143</b>
DAN 40U	<b>144-145</b>
DAN 45U	<b>146-147</b>
DAN 50U	<b>148-149</b>
DAN 55U	<b>150-151</b>

**Vantis**

V 34U	<b>152-153</b>
V 40U	<b>154-155</b>
V 45U	<b>156-157</b>
V 50-42U	<b>158-159</b>
V 50-35U + V 11U	<b>160-161</b>
V 55U	<b>162-163</b>
VG 45U Green	<b>164</b>
VG 50-42U Green	<b>165</b>
VG 50-35U Green	<b>166</b>
VG 55U Green	<b>167</b>
VX 34U Varix	<b>168</b>
VX 40U Varix	<b>169</b>
VX 45U Varix	<b>170</b>
VX 50-42U Varix	<b>171</b>
VX 55U Varix	<b>172</b>

**Silver Star**

SIL 18U + SIL 34U	<b>173</b>
SIL 18/34U	<b>174</b>
SIL 45U	<b>175</b>
SIS 50U	<b>176</b>
SIL 50U + SIL 9U	<b>177</b>
SIL 55U	<b>179</b>
SX 40U Varix	<b>180</b>
SX 50-42U Varix	<b>181</b>

**Comfort**

COM 34U	<b>182</b>
COM 40U	<b>183</b>

**Accento**

A 65U	<b>184</b>
A 75U	<b>185</b>
A 40/34U	<b>186</b>

**Gastro MaXX**

MGM 1U + MGM 2U	<b>187</b>
-----------------	------------

**Rund**

R 44BU	<b>187</b>
--------	------------

**Granit (Cristadur)**

Granito (Cristadur)

**Linero**

LIO CD 50U	<b>188-191</b>
LIO CDAB 50U Black Edition	<b>192-195</b>

**Granit (Cristalite Plus)**

Granito (Cristalite Plus)

**Daneo**

DAN CP 45U	<b>196</b>
DAN CP 50U	<b>198</b>
DAN CP 55U	<b>200</b>

**Brooklyn**

BYK N 100S U	<b>202</b>
BYKAB N 100S U Black Edition	<b>203</b>
BYK N 100U	<b>204</b>
BYKAB N 100U Black Edition	<b>205</b>
BYK N 100L U	<b>206</b>
BYKAB N 100L U Black Edition	<b>207</b>

**Carbon/Carbonio**

**Carbon**

CAR N 100U	<b>208</b>
------------	------------

**Montagematerial/Materiale per il montaggio**





































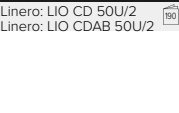

































































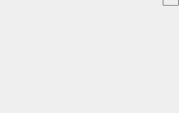

















Befestigungsklammern für Unterbau-Becken  
Staffe di fissaggio per lavelli sottopiano  
40.000.437.00

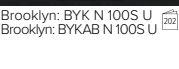

Befestigungsklammern für Unterbau-Becken Schock Granitspülen  
Staffe di fissaggio per lavelli sottopiano in granito Schock  
40.002.461.00

Sortiment nach Unterschrankmassen/Assortimento per dimensioni di base

Unterbau-Becken  
Lavelli sottopiano

	35cm	40cm	45cm	50cm	55cm	
<b>Linerio</b> sFlow, Typ M sFlow, tipo M	 Linero: LIO 18U 	 Linero: LIO 34U 	 Linero: LIO 40U 	 Linero: LIO 45U 	 Linero: LIO 50U 	 Linero: LIO CD 50U/2   Linero: LIO CDAB 50U/2 
	 Linero: LIO 18U 	 Linero: LIO 34U 	 Linero: LIO 40U 	 Linero: LIO 45U 	 Linero: LIO 50U 	 Linero: LIO CD 50U/2   Linero: LIO CDAB 50U/2 
<b>Daneo</b> sFlow, Typ S sFlow, tipo S	 Daneo: DAN 18U 	 Daneo: DAN 34U 	 Daneo: DAN 40U 	 Daneo: DAN 45U 	 Daneo: DAN 50U 	
	 Daneo: DAN 18U 	 Daneo: DAN 34U 	 Daneo: DAN 40U 	 Daneo: DAN 45U 	 Daneo: DAN 50U 	
<b>Vantis</b> sFlow, Typ M sFlow, tipo M	 Vantis: V 11U 	 Vantis: V 34U 	 Vantis: V 40U 	 Vantis: V 45U 	 Vantis: V 50-42U 	 Vantis: V 50-35U   Vantis: V 50-35U + V 11U 
	 Vantis: V 11U 	 Vantis: V 34U 	 Vantis: V 40U 	 Vantis: V 45U 	 Vantis: V 50-42U 	 Vantis: V 50-35U   Vantis: V 50-35U + V 11U 
<b>Vantis</b> sFlow, Typ S sFlow, tipo S		 Vantis: VX 34U Varix 	 Vantis: VX 40U Varix 	 Vantis: VG 45U Green 	 Vantis: VG 50-42U Green 	 Vantis: VG 50-35U Green 
		 Vantis: VX 45U Varix 	 Vantis: VX 50-42U Varix 	 Vantis: VG 45U Green 	 Vantis: VG 50-42U Green 	 Vantis: VG 50-35U Green 
<b>Silver Star</b>	 Silver Star: SIL 9U 	 Silver Star: SIL 34U 		 Silver Star: SIL 45U 	 Silver Star: SIS 50U 	 Silver Star: SIL 50U + SIL 9U 
	 Silver Star: SIL 18U 		 Silver Star: SX 40U Varix 		 Silver Star: SX 50-42U Varix 	
<b>Comfort / Accento</b>		 Comfort: COM 34U 	 Comfort: COM 40U 			
<b>Einzel-Becken Lavelli a vasca singola</b>		 Rund: R 44BU 	 Brooklyn: BYK N 100S U   Brooklyn: BYKAB N 100S U 	 Brooklyn: BYK N 100U   Brooklyn: BYKAB N 100U 		

**GREEN LINE** Green Line ist eine eigenständige auf Nachhaltigkeit ausgerichtete Produktausführung.  
Green Line è una versione di prodotto autonoma calibrata sulla sostenibilità.

Auffrisch- und Pflegeservice  
Mehr Infos siehe Seite 25  
Servizio di pulizia e manutenzione  
Per maggiori informazioni, vedere pag. 25

60cm

80cm





Linero: LIO 18U + LIO 34U 



Linero: LIO 55U 



Linero: LIO CD 50U/1   
Linero: LIO CDAB 50U/1 





Linero: LIO 18U + LIO 34U 



Linero: LIO 55U 



Linero: LIO CD 50U/1   
Linero: LIO CDAB 50U/1 



Daneo: DAN 18U + DAN 34U 



Daneo: DAN 55U 



Daneo: DAN 18U + DAN 34U 



Daneo: DAN 55U 



Daneo: DAN CP 50U/1 



Daneo: DAN CP 55U 



Vantis: V 55U 



Vantis: V 55U 



Vantis: VG 55U Green 



Vantis: VX 55U Varix 



Silver Star: SIL 18U + SIL 34U 



Silver Star: SIL 55U 



Silver Star: SIL 18/34U 



Accento: A 65U   
Accento: A 75U 



Accento: A 40/34U 



Brooklyn: BYK N 100L U   
Brooklyn: BYKAB N 100L U 



Carbon: CAR N 100U 

## Linero: LIO 18U + LIO 34U

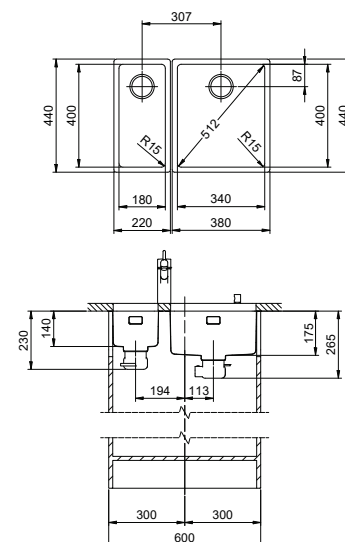

Schwenkbare Überlaufkappe  
Placchetta di troppopieno a ribalta



Obenliegendes Sieb  
Griglietta superiore



Zeichnung als pdf / dxf und Montageanleitung siehe:  
V. disegno in formato pdf / dxf e montaggio:  
suter.ch



Varianten: Der Austausch von Zugknöpfen erfolgt mittels Variantencode. Mehr Infos siehe Seite 395.  
Varianti: La sostituzione di pomoli avviene mediante codice variante. Per maggiori informazioni, vedere pag. 395.

## Preis CHF/Prezzo in CHF

Modell Modello	Material Materiale		Ventil sFlow, Typ M Piletta sFlow, tipo M	Artikel-Nr. N. di articolo	Beckentiefe Profondità	Exkl. MWST IVA esclusa	Inkl. MWST IVA inclusa	VRG TRA	
<b>Linero LIO 18U</b>	Edelstahl, matt Acciaio inox, opaco	18/10	3 1/2" Tipo	10.105.532.00	140 mm	A	810.–	876.–	
<b>Linero LIO 34U</b>	Edelstahl, matt Acciaio inox, opaco	18/10	3 1/2" TouchFlow	10.105.534.00	175 mm	A	1323.–	1430.–	0.19
			3 1/2" Druckknopf Pulsante	10.106.235.00	175 mm	A	1170.–	1265.–	
			3 1/2" Raumspar Salvaspazio	10.105.535.00	175 mm	A	1125.–	1216.–	
			3 1/2" Tipo	10.105.536.00	175 mm	A	1084.–	1172.–	
<b>Linero LIO 18U + Linero LIO 34U</b>	Edelstahl, matt Acciaio inox, opaco	18/10	3 1/2" Tipo + TouchFlow	10.105.540.00	140 mm 175 mm	A	2075.–	2243.–	0.19
			3 1/2" Tipo + Druckknopf Tipo + Pulsante	10.106.236.00	140 mm 175 mm	A	1922.–	2078.–	
			3 1/2" Tipo + Raumspar Tipo + Salvaspazio	10.105.541.00	140 mm 175 mm	A	1877.–	2029.–	
			3 1/2" Tipo + Tipo	10.105.542.00	140 mm 175 mm	A	1836.–	1985.–	

Linero: LIO 18U + LIO 34U

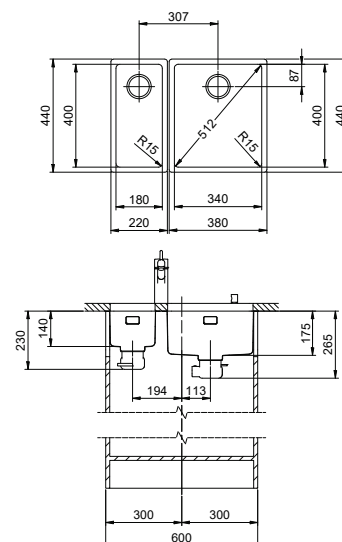

eFlow mit eControl  
eFlow con eControl

Schwenkbare Überlaufkappe  
Placchetta di troppopieno a ribalta

Desino: Verdeckter Ablauf mit untenliegendem Korb  
Desino: Scarico coperto con griglietta inferiore



Für eFlow Desino  
Per eFlow Desino



Für TouchFlow Desino, Raumspar Desino und Tipo Desino  
Per TouchFlow Desino, Salvaspazio Desino e Tipo Desino



Für eFlow Desino, TouchFlow Desino, Raumspar Desino und Tipo Desino  
Per eFlow Desino, TouchFlow Desino, Salvaspazio Desino e Tipo Desino



Kombination LIO 18U + LIO 34U mit eFlow Desino oder TouchFlow Desino:  
Erfordert beidseitigen Ausschnitt der Korpuswand, bei LIO 18U mit vergrössertem Ausschnitt.  
Combinazione LIO 18U + LIO 34U con eFlow Desino o TouchFlow Desino:  
Richiede un intaglio della parete dell'armadio su entrambi i lati, per LIO 18U un intaglio allargato.

Zeichnung als pdf / dxf und Montageanleitung siehe:  
V. disegno in formato pdf / dxf e montaggio:  
suter.ch

Varianten: Der Austausch von Zugknöpfen erfolgt mittels Variantencode. Mehr Infos siehe Seite 395.  
Varianti: La sostituzione di pomoli avviene mediante codice variante. Per maggiori informazioni, vedere pag. 395.

Preis CHF/Prezzo in CHF

Modell Modello	Material Materiale	Ventil sFlow, Typ M Piletta sFlow, tipo M	Artikel-Nr. N. di articolo	Beckentiefe Profondità	Exkl. MWST IVA esclusa	Inkl. MWST IVA inclusa	VRG TRA		
Linero LIO 18U	Edelstahl, matt Acciaio inox, opaco	18 / 10	3 1/2" eFlow Desino	10.105.216.00	140 mm	A	1316.–	1423.–	0.19
			3 1/2" TouchFlow Desino	10.105.217.00	140 mm	A	1201.–	1298.–	0.19
			3 1/2" Tipo Desino	10.105.530.00	140 mm	A	991.–	1071.–	
Linero LIO 34U	Edelstahl, matt Acciaio inox, opaco	18 / 10	3 1/2" eFlow Desino	10.105.218.00	175 mm	A	1590.–	1719.–	0.19
			3 1/2" TouchFlow Desino	10.105.219.00	175 mm	A	1475.–	1594.–	0.19
			3 1/2" Raumspar Desino Salvaspazio Desino	10.105.220.00	175 mm	A	1265.–	1367.–	
			3 1/2" Tipo Desino	10.105.533.00	175 mm	A	1265.–	1367.–	
Linero LIO 18U + Linero LIO 34U	Edelstahl, matt Acciaio inox, opaco	18 / 10	3 1/2" Tipo Desino + TouchFlow Desino	10.105.537.00	140 mm 175 mm	A	2398.–	2592.–	0.19
			3 1/2" Tipo Desino + Raumspar Desino Salvaspazio Desino	10.105.538.00	140 mm 175 mm	A	2188.–	2365.–	
			3 1/2" Tipo Desino + Tipo Desino	10.105.539.00	140 mm 175 mm	A	2188.–	2365.–	

## Linero: LIO 40U

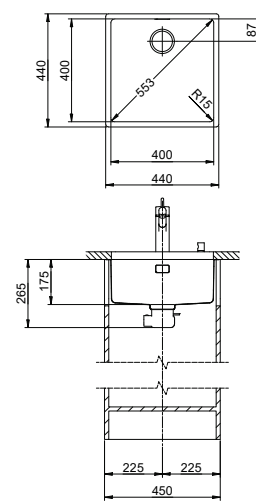
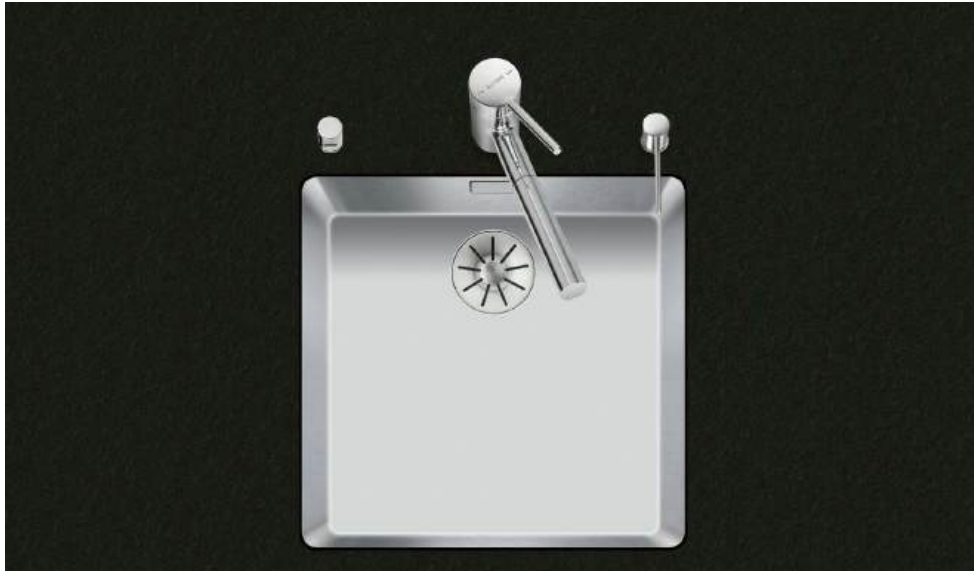

Schwenkbare Überlaufkappe  
Placchetta di troppopieno a ribalta

15

Obenliegendes Sieb  
Griglietta superiore

14



## Optionales Zubehör/Accessori opzionali

312



**Resteschale** gelocht  
**Vaschetta** forato

CHF 106.– 40.000.912.00

**Resteschale** ungelocht  
**Vaschetta** non forato

CHF 106.– 40.001.289.00

**Schneidebrett** aus Glas  
**Tagliere** in vetro

CHF 151.– 40.000.909.00

**Schneidebrett** aus Kunststoff  
**Tagliere** sintetico

CHF 151.– 40.001.277.00

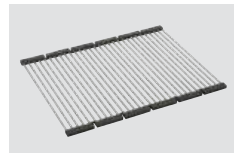
**Inox Pad**

CHF 125.– 40.001.138.00

Zeichnung als pdf/dxf und Montageanleitung siehe:  
V. disegno in formato pdf/dxf e montaggio:  
suter.ch



Varianten: Der Austausch von Zugknöpfen erfolgt mittels Variantencode. Mehr Infos siehe Seite 395.  
Varianti: La sostituzione di pomoli avviene mediante codice variante. Per maggiori informazioni, vedere pag. 395.

Preis CHF/Prezzo in CHF

Modell Modello	Material Materiale	Ventil sFlow, Typ M Piletta sFlow, tipo M	Artikel-Nr. N. di articolo	Beckentiefe Profondità	Exkl. MWST IVA esclusa	Inkl. MWST IVA inclusa	VRG TRA		
Linero LIO 40U	Edelstahl, matt Acciaio inox, opaco	18/10	3 1/2" TouchFlow	10.105.544.00	175 mm	A	1386.–	1498.–	0.19
			3 1/2" Druckknopf Pulsante	10.106.237.00	175 mm	A	1233.–	1333.–	
			3 1/2" Raumspar Salvaspazio	10.105.545.00	175 mm	A	1188.–	1284.–	
			3 1/2" Tipo	10.105.546.00	175 mm	A	1147.–	1240.–	

Linero: LIO 40U

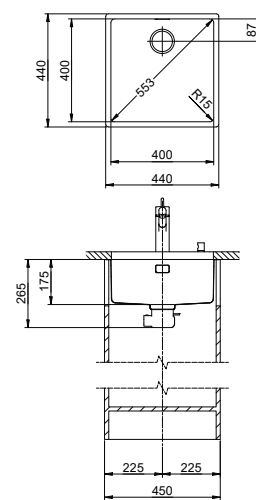

eFlow mit eControl  
eFlow con eControl

Schwenkbare Überlaufkappe  
Placchetta di troppopieno a ribalta

Desino: Verdeckter Ablauf mit untenliegendem Korb  
Desino: Scarico coperto con griglietta inferiore



Für eFlow Desino  
Per eFlow Desino



Für TouchFlow Desino, Raumspaar Desino und Tipo Desino  
Per TouchFlow Desino, Salvaspazio Desino e Tipo Desino



Für eFlow Desino, TouchFlow Desino, Raumspaar Desino und Tipo Desino  
Per eFlow Desino, TouchFlow Desino, Salvaspazio Desino e Tipo Desino

Optionales Zubehör/Accessori opzionali

312



**Resteschale** gelocht  
**Vaschetta** forato

CHF 106.– 40.000.912.00



**Resteschale** ungelocht  
**Vaschetta** non forato

CHF 106.– 40.001.289.00



**Schneidebrett** aus Glas  
**Tagliere** in vetro

CHF 151.– 40.000.909.00



**Schneidebrett** aus Kunststoff  
**Tagliere** sintetico

CHF 151.– 40.001.277.00

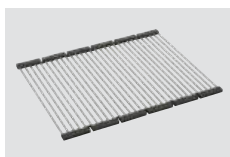

**Inox Pad**

CHF 125.– 40.001.138.00

Zeichnung als pdf / dxf und Montageanleitung siehe:  
V. disegno in formato pdf / dxf e montaggio:  
suter.ch

Varianten: Der Austausch von Zugknöpfen erfolgt mittels Variantencode. Mehr Infos siehe Seite 395.  
Varianti: La sostituzione di pomoli avviene mediante codice variante. Per maggiori informazioni, vedere pag. 395.

Preis CHF/Prezzo in CHF

Modell Modello	Material Materiale	Ventil sFlow, Typ M Piletta sFlow, tipo M	Artikel-Nr. N. di articolo	Beckentiefe Profondità	Exkl. MWST IVA esclusa	Inkl. MWST IVA inclusa	VRG TRA	
<b>Linero LIO 40U</b>	Edelstahl, matt Acciaio inox, opaco	3 1/2" eFlow Desino	10.105.221.00	175 mm	A	1653.–	1787.–	0.19
		3 1/2" TouchFlow Desino	10.105.222.00	175 mm	A	1538.–	1663.–	0.19
		3 1/2" Raumspaar Desino Salvaspazio Desino	10.105.223.00	175 mm	A	1328.–	1436.–	
		3 1/2" Tipo Desino	10.105.543.00	175 mm	A	1328.–	1436.–	

## Linero: LIO 45U

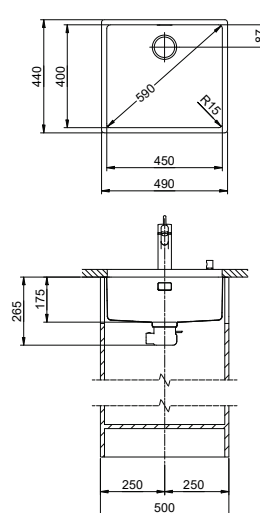

Schwenkbare Überlaufkappe  
Placchetta di troppopieno a ribalta

15

Obenliegendes Sieb  
Griglietta superiore

14



## Optionales Zubehör/Accessori opzionali

312



**Resteschale** gelocht  
**Vaschetta** forato

CHF 106.– 40.000.912.00

**Resteschale** ungelocht  
**Vaschetta** non forato

CHF 106.– 40.001.289.00

**Schneidebrett** aus Glas  
**Tagliere** in vetro

CHF 151.– 40.000.909.00

**Schneidebrett** aus Kunststoff  
**Tagliere** sintetico

CHF 151.– 40.001.277.00

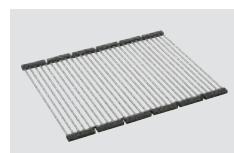
**Inox Pad**

CHF 125.– 40.001.138.00

Zeichnung als pdf/dxf und Montageanleitung siehe:  
V. disegno in formato pdf/dxf e montaggio:  
suter.ch

Varianten: Der Austausch von Zugknöpfen erfolgt mittels Variantencode. Mehr Infos siehe Seite 395.  
Varianti: La sostituzione di pomoli avviene mediante codice variante. Per maggiori informazioni, vedere pag. 395.

Preis CHF/Prezzo in CHF

Modell Modello	Material Materiale	Ventil sFlow, Typ M Piletta sFlow, tipo M	Artikel-Nr. N. di articolo	Beckentiefe Profondità	Exkl. MWST IVA esclusa	Inkl. MWST IVA inclusa	VRG TRA		
<b>Linero LIO 45U</b>	Edelstahl, matt Acciaio inox, opaco	18/10	3 1/2" TouchFlow	10.105.548.00	175 mm	A	1411.–	1525.–	0.19
			3 1/2" Druckknopf Pulsante	10.106.238.00	175 mm	A	1258.–	1360.–	
			3 1/2" Raumspar Salvaspazio	10.105.549.00	175 mm	A	1213.–	1311.–	
			3 1/2" Tipo	10.105.550.00	175 mm	A	1172.–	1267.–	

Linero: LIO 45U

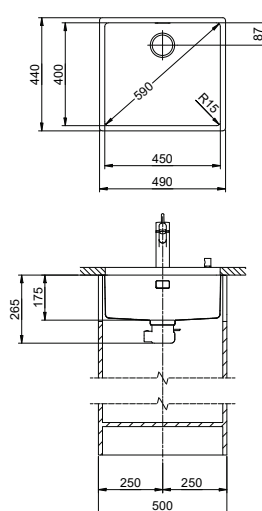

eFlow mit eControl  
eFlow con eControl

Schwenkbare Überlaufkappe  
Placchetta di troppopieno a ribalta

Desino: Verdeckter Ablauf mit untenliegendem Korb  
Desino: Scarico coperto con griglietta inferiore



Für eFlow Desino  
Per eFlow Desino



Für TouchFlow Desino, Raumspars Desino und Tipo Desino  
Per TouchFlow Desino, Salvaspazio Desino e Tipo Desino



Für eFlow Desino, TouchFlow Desino, Raumspars Desino und Tipo Desino  
Per eFlow Desino, TouchFlow Desino, Salvaspazio Desino e Tipo Desino



Optionales Zubehör / Accessori opzionali

312



**Resteschale** gelocht  
**Vaschetta** forato

CHF 106.– 40.000.912.00



**Resteschale** ungelocht  
**Vaschetta** non forato

CHF 106.– 40.001.289.00



**Schneidebrett** aus Glas  
**Tagliere** in vetro

CHF 151.– 40.000.909.00



**Schneidebrett** aus Kunststoff  
**Tagliere** sintetico

CHF 151.– 40.001.277.00

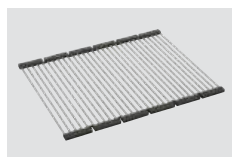

**Inox Pad**

CHF 125.– 40.001.138.00

Zeichnung als pdf / dxf und Montageanleitung siehe:  
V. disegno in formato pdf / dxf e montaggio:  
suter.ch

Varianten: Der Austausch von Zugknöpfen erfolgt mittels Variantencode. Mehr Infos siehe Seite 395.  
Varianti: La sostituzione di pomoli avviene mediante codice variante. Per maggiori informazioni, vedere pag. 395.

Preis CHF / Prezzo in CHF

Modell Modello	Material Materiale	Ventil sFlow, Typ M Piletta sFlow, tipo M	Artikel-Nr. N. di articolo	Beckentiefe Profondità	Exkl. MWST IVA esclusa	Inkl. MWST IVA inclusa	VRG TRA		
<b>Linero LIO 45U</b>	Edelstahl, matt Acciaio inox, opaco	18/10	3 1/2" eFlow Desino	10.105.224.00	175 mm	A	1678.–	1814.–	0.19
			3 1/2" TouchFlow Desino	10.105.225.00	175 mm	A	1563.–	1690.–	0.19
			3 1/2" Raumspars Desino Salvaspazio Desino	10.105.226.00	175 mm	A	1353.–	1463.–	
			3 1/2" Tipo Desino	10.105.547.00	175 mm	A	1353.–	1463.–	

## Linero: LIO 50U

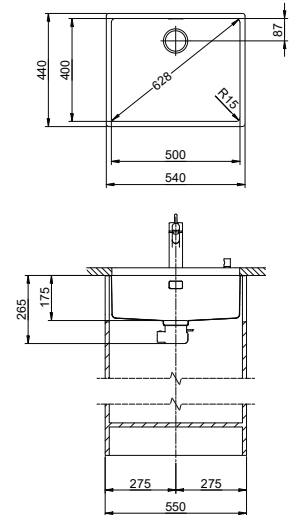
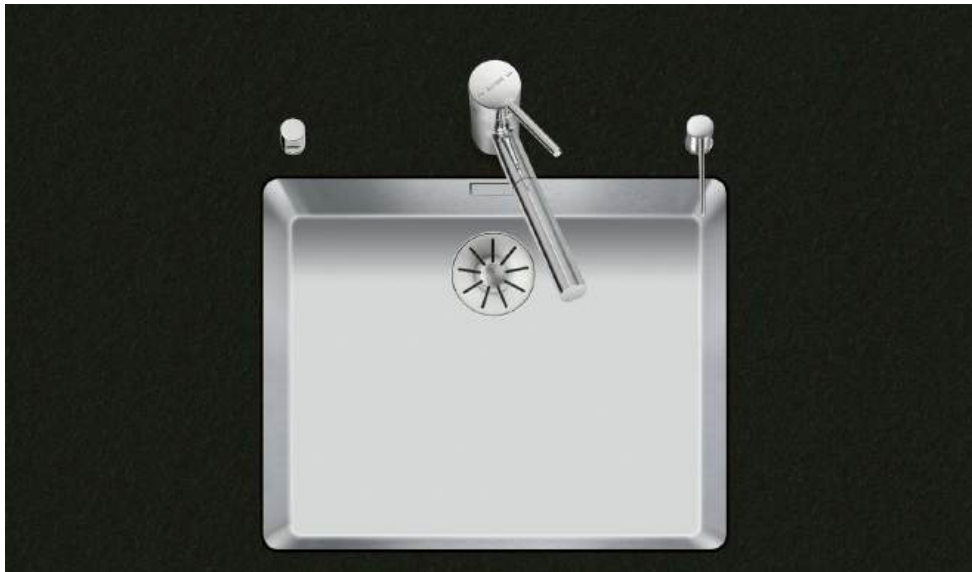

Schwenkbare Überlaufkappe  
Placchetta di troppopieno a ribalta

15

Obenliegendes Sieb  
Griglietta superiore

14



## Optionales Zubehör/Accessori opzionali

312



**Resteschale** gelocht  
**Vaschetta** forato

CHF 106.– 40.000.912.00

**Resteschale** ungelocht  
**Vaschetta** non forato

CHF 106.– 40.001.289.00

**Schneidebrett** aus Glas  
**Tagliere** in vetro

CHF 151.– 40.000.909.00

**Schneidebrett** aus Kunststoff  
**Tagliere** sintetico

CHF 151.– 40.001.277.00

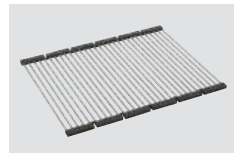
**Innox Pad**

CHF 125.– 40.001.138.00

Zeichnung als pdf/dxf und Montageanleitung siehe:  
V. disegno in formato pdf/dxf e montaggio:  
suter.ch



Varianten: Der Austausch von Zugknöpfen erfolgt mittels Variantencode. Mehr Infos siehe Seite 395.  
Varianti: La sostituzione di pomoli avviene mediante codice variante. Per maggiori informazioni, vedere pag. 395.

Preis CHF/Prezzo in CHF

Modell Modello	Material Materiale	Ventil sFlow, Typ M Piletta sFlow, tipo M	Artikel-Nr. N. di articolo	Beckentiefe Profondità	Exkl. MWST IVA esclusa	Inkl. MWST IVA inclusa	VRG TRA		
<b>Linero LIO 50U</b>	Edelstahl, matt Acciaio inox, opaco	18/10	3 1/2" TouchFlow	10.105.552.00	175 mm	A	1434.–	1550.–	0.19
			3 1/2" Druckknopf Pulsante	10.106.239.00	175 mm	A	1281.–	1385.–	
			3 1/2" Raumspar Salvaspazio	10.105.553.00	175 mm	A	1236.–	1336.–	
			3 1/2" Tipo	10.105.554.00	175 mm	A	1195.–	1292.–	

# Linero: LIO 50U

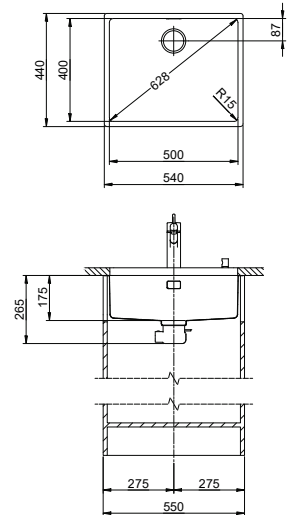

eFlow mit eControl  
eFlow con eControl

13

Schwenkbare Überlaufkappe  
Placchetta di troppopieno a ribalta

13

Desino: Verdeckter Ablauf mit untenliegendem Korb  
Desino: Scarico coperto con griglietta inferiore

12



Für eFlow Desino  
Per eFlow Desino



Für TouchFlow Desino, Raumspaar Desino und Tipo Desino  
Per TouchFlow Desino, Salvaspazio Desino e Tipo Desino



Für eFlow Desino, TouchFlow Desino, Raumspaar Desino und Tipo Desino  
Per eFlow Desino, TouchFlow Desino, Salvaspazio Desino e Tipo Desino

## Optionales Zubehör/Accessori opzionali

312



**Resteschale** gelocht  
**Vaschetta** forato

CHF 106.– 40.000.912.00



**Resteschale** ungelocht  
**Vaschetta** non forato

CHF 106.– 40.001.289.00



**Schneidebrett** aus Glas  
**Tagliere** in vetro

CHF 151.– 40.000.909.00



**Schneidebrett** aus Kunststoff  
**Tagliere** sintetico

CHF 151.– 40.001.277.00

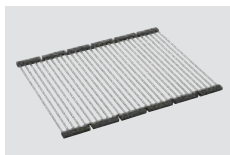

**Inox Pad**

CHF 125.– 40.001.138.00

Zeichnung als pdf / dxf und Montageanleitung siehe:  
V. disegno in formato pdf / dxf e montaggio:  
suter.ch

Varianten: Der Austausch von Zugknöpfen erfolgt mittels Variantencode. Mehr Infos siehe Seite 395.  
Varianti: La sostituzione di pomoli avviene mediante codice variante. Per maggiori informazioni, vedere pag. 395.

## Preis CHF/Prezzo in CHF

Modell Modello	Material Materiale	Ventil sFlow, Typ M Piletta sFlow, tipo M	Artikel-Nr. N. di articolo	Beckentiefe Profondità	Exkl. MWST IVA esclusa	Inkl. MWST IVA inclusa	VRG TRA		
<b>Linero LIO 50U</b>	Edelstahl, matt Acciaio inox, opaco	18/10	3 1/2" eFlow Desino	10.105.227.00	175 mm	A	1701.–	1839.–	0.19
			3 1/2" TouchFlow Desino	10.105.228.00	175 mm	A	1586.–	1714.–	0.19
			3 1/2" Raumspaar Desino Salvaspazio Desino	10.105.229.00	175 mm	A	1376.–	1487.–	
			3 1/2" Tipo Desino	10.105.551.00	175 mm	A	1376.–	1487.–	

## Linero: LIO 55U

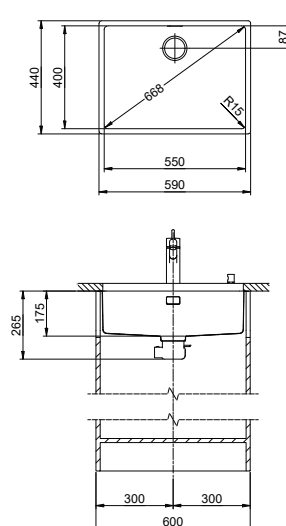

Schwenkbare Überlaufkappe  
Placchetta di troppopieno a ribalta

15

Obenliegendes Sieb  
Griglietta superiore

14



## Optionales Zubehör/Accessori opzionali

312



**Resteschale** gelocht  
**Vaschetta** forato

CHF 106.– 40.000.912.00

**Resteschale** ungelocht  
**Vaschetta** non forato

CHF 106.– 40.001.289.00

**Schneidebrett** aus Glas  
**Tagliere** in vetro

CHF 151.– 40.000.909.00

**Schneidebrett** aus Kunststoff  
**Tagliere** sintetico

CHF 151.– 40.001.277.00

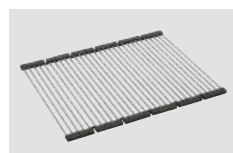
**Innox Pad**

CHF 125.– 40.001.138.00

Zeichnung als pdf/dxf und Montageanleitung siehe:  
V. disegno in formato pdf/dxf e montaggio:  
suter.ch

Varianten: Der Austausch von Zugknöpfen erfolgt mittels Variantencode. Mehr Infos siehe Seite 395.  
Varianti: La sostituzione di pomoli avviene mediante codice variante. Per maggiori informazioni, vedere pag. 395.

Preis CHF/Prezzo in CHF

Modell Modello	Material Materiale	Ventil sFlow, Typ M Piletta sFlow, tipo M	Artikel-Nr. N. di articolo	Beckentiefe Profondità	Exkl. MWST IVA esclusa	Inkl. MWST IVA inclusa	VRG TRA		
<b>Linero LIO 55U</b>	Edelstahl, matt Acciaio inox, opaco	18/10	3 1/2" TouchFlow	10.105.556.00	175 mm	A	1522.–	1645.–	0.19
			3 1/2" Druckknopf Pulsante	10.106.240.00	175 mm	A	1369.–	1480.–	
			3 1/2" Raumspar Salvaspazio	10.105.557.00	175 mm	A	1324.–	1431.–	
			3 1/2" Tipo	10.105.558.00	175 mm	A	1283.–	1387.–	

Linero: LIO 55U

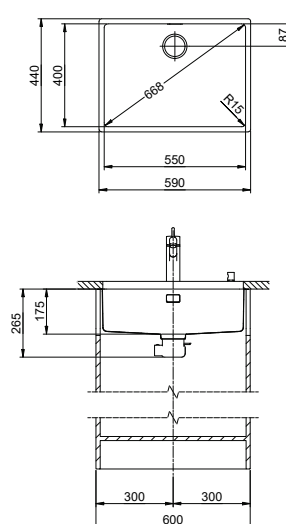

eFlow mit eControl  
eFlow con eControl

Schwenkbare Überlaufkappe  
Placchetta di troppopieno a ribalta

Desino: Verdeckter Ablauf mit untenliegendem Korb  
Desino: Scarico coperto con griglietta inferiore



Für eFlow Desino  
Per eFlow Desino



Für TouchFlow Desino, Raumspar Desino und Tipo Desino  
Per TouchFlow Desino, Salvaspazio Desino e Tipo Desino



Für eFlow Desino, TouchFlow Desino, Raumspar Desino und Tipo Desino  
Per eFlow Desino, TouchFlow Desino, Salvaspazio Desino e Tipo Desino

Optionales Zubehör/Accessori opzionali

312



**Resteschale** gelocht  
**Vaschetta** forato

CHF 106.– 40.000.912.00



**Resteschale** ungelocht  
**Vaschetta** non forato

CHF 106.– 40.001.289.00



**Schneidebrett** aus Glas  
**Tagliere** in vetro

CHF 151.– 40.000.909.00



**Schneidebrett** aus Kunststoff  
**Tagliere** sintetico

CHF 151.– 40.001.277.00

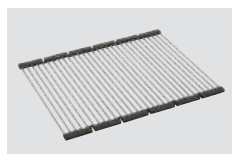

**Inox Pad**

CHF 125.– 40.001.138.00

Zeichnung als pdf / dxf und Montageanleitung siehe:  
V. disegno in formato pdf / dxf e montaggio:  
suter.ch

Varianten: Der Austausch von Zugknöpfen erfolgt mittels Variantencode. Mehr Infos siehe Seite 395.  
Varianti: La sostituzione di pomoli avviene mediante codice variante. Per maggiori informazioni, vedere pag. 395.

Preis CHF/Prezzo in CHF

Modell Modello	Material Materiale	Ventil sFlow, Typ M Piletta sFlow, tipo M	Artikel-Nr. N. di articolo	Beckentiefe Profondità	Exkl. MWST IVA esclusa	Inkl. MWST IVA inclusa	VRG TRA		
<b>Linero LIO 55U</b>	Edelstahl, matt Acciaio inox, opaco	18/10	3 1/2" eFlow Desino	10.105.230.00	175 mm	A	1789.–	1934.–	0.19
			3 1/2" TouchFlow Desino	10.105.231.00	175 mm	A	1674.–	1810.–	0.19
			3 1/2" Raumspar Desino Salvaspazio Desino	10.105.232.00	175 mm	A	1464.–	1583.–	
			3 1/2" Tipo Desino	10.105.555.00	175 mm	A	1464.–	1583.–	

## Daneo: DAN 18U + DAN 34U

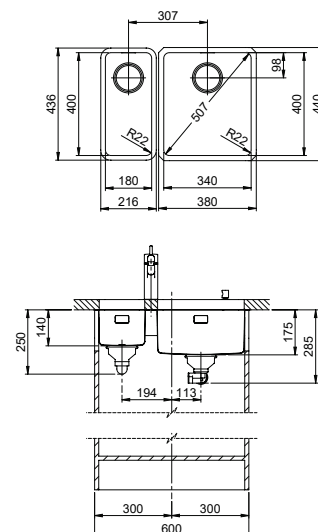

Schwenkbare Überlaufkappe  
Placchetta di troppopieno a ribalta

15

Obenliegendes Sieb  
Griglietta superiore

14



Zeichnung als pdf / dxf und Montageanleitung siehe:  
V. disegno in formato pdf / dxf e montaggio:  
suter.ch

## Optionales Zubehör/Accessori opzionali

312



**Resteschale** gelocht  
**Vaschetta** forato

CHF 106.– 40.000.912.00

**Resteschale** ungelocht  
**Vaschetta** non forato

CHF 106.– 40.001.289.00

**Schneidebrett** aus Glas  
**Tagliere** in vetro

CHF 151.– 40.000.909.00

**Schneidebrett** aus Kunststoff  
**Tagliere** sintetico

CHF 151.– 40.001.277.00

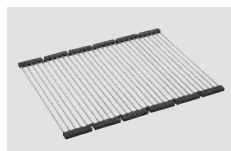

**Inox Pad**

CHF 125.– 40.001.138.00



Varianten: Der Austausch von Zugknöpfen erfolgt  
mittels Variantencode. Mehr Infos siehe Seite 395.  
Varianti: La sostituzione di pomoli avviene mediante codice  
variante. Per maggiori informazioni, vedere pag. 395.

## Preis CHF/Prezzo in CHF

Modell Modello	Material Materiale	Ventil sFlow, Typ S Piletta sFlow, tipo S	Artikel-Nr. N. di articolo	Beckentiefe Profondità	Exkl. MWST IVA esclusa	Inkl. MWST IVA inclusa	VRG TRA		
<b>Daneo DAN 18U</b>	Edelstahl, matt Acciaio inox, opaco	18 / 10	3 1/2" Tipo	10.103.806.00	140 mm	A	742.–	802.–	
			3 1/2" TouchFlow	10.103.789.00	175 mm	A	941.–	1017.–	0.19
<b>Daneo DAN 34U</b>	Edelstahl, matt Acciaio inox, opaco	18 / 10	3 1/2" Raumspar Salvaspazio	10.103.790.00	175 mm	A	743.–	803.–	
			3 1/2" Tipo	10.103.791.00	175 mm	A	702.–	759.–	
<b>Daneo DAN 18U + Daneo DAN 34U</b>	Edelstahl, matt Acciaio inox, opaco	18 / 10	3 1/2" Tipo + TouchFlow	10.103.810.00	140 mm 175 mm	A	1638.–	1771.–	0.19
			3 1/2" Tipo + Raumspar Tipo + Salvaspazio	10.103.811.00	140 mm 175 mm	A	1440.–	1557.–	
			3 1/2" Tipo + Tipo	10.103.812.00	140 mm 175 mm	A	1399.–	1512.–	

# Daneo: DAN 18U + DAN 34U

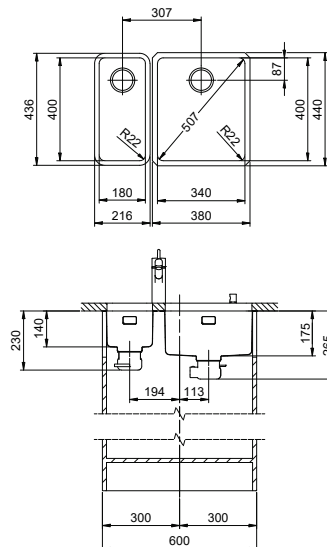

eFlow mit eControl  
eFlow con eControl

Schwenkbare Überlaufkappe  
Placchetta di troppopieno a ribalta

Desino: Verdeckter Ablauf mit untenliegendem Korb  
Desino: Scarico coperto con griglietta inferiore



Für eFlow Desino  
Per eFlow Desino



Für TouchFlow Desino, Raumspar Desino und Tipo Desino  
Per TouchFlow Desino, Salvaspazio Desino e Tipo Desino



Für eFlow Desino, TouchFlow Desino, Raumspar Desino und Tipo Desino  
Per eFlow Desino, TouchFlow Desino, Salvaspazio Desino e Tipo Desino



Kombination DAN 18U + DAN 34U mit eFlow Desino oder TouchFlow Desino:  
Erfordert beidseitigen Ausschnitt der Korpuswand, bei DAN 18U mit vergrößerter Ausschnitt.  
Combinazione DAN 18U + DAN 34U con eFlow Desino o TouchFlow Desino:  
Richiede un intaglio della parete dell'armadio su entrambi i lati, per DAN 18U un intaglio allargato.

Zeichnung als pdf / dxf und Montageanleitung siehe:  
V. disegno in formato pdf / dxf e montaggio:  
suter.ch

Varianten: Der Austausch von Zugknöpfen erfolgt mittels Variantencode. Mehr Infos siehe Seite 395.  
Varianti: La sostituzione di pomoli avviene mediante codice variante. Per maggiori informazioni, vedere pag. 395.

## Preis CHF/Prezzo in CHF

Modell Modello	Material Materiale	Ventil sFlow, Typ M Piletta sFlow, tipo M	Artikel-Nr. N. di articolo	Beckentiefe Profondità	Exkl. MWST IVA esclusa	Inkl. MWST IVA inclusa	VRG TRA		
Daneo DAN 18U	Edelstahl, matt Acciaio inox, opaco	18 / 10	3 1/2" eFlow Desino	10.104.663.00	140 mm	A	1248.–	1349.–	0.19
			3 1/2" TouchFlow Desino	10.104.631.00	140 mm	A	1133.–	1225.–	0.19
			3 1/2" Tipo Desino	10.105.593.00	140 mm	A	923.–	998.–	
Daneo DAN 34U	Edelstahl, matt Acciaio inox, opaco	18 / 10	3 1/2" eFlow Desino	10.104.664.00	175 mm	A	1208.–	1306.–	0.19
			3 1/2" TouchFlow Desino	10.104.632.00	175 mm	A	1093.–	1182.–	0.19
			3 1/2" Raumspar Desino Salvaspazio Desino	10.104.633.00	175 mm	A	883.–	955.–	
			3 1/2" Tipo Desino	10.105.596.00	175 mm	A	883.–	955.–	
Daneo DAN 18U + Daneo DAN 34U	Edelstahl, matt Acciaio inox, opaco	18 / 10	3 1/2" Tipo Desino + TouchFlow Desino	10.105.600.00	140 mm 175 mm	A	1962.–	2121.–	0.19
			3 1/2" Tipo Desino + Raumspar Desino Salvaspazio Desino	10.105.601.00	140 mm 175 mm	A	1752.–	1894.–	
			3 1/2" Tipo Desino + Tipo Desino	10.105.602.00	140 mm 175 mm	A	1752.–	1894.–	

## Daneo: DAN 40U

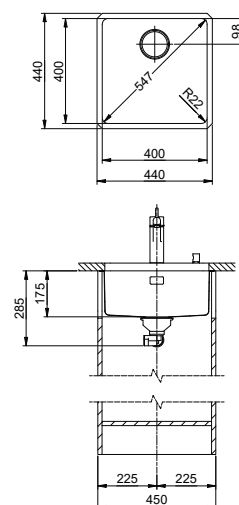

Schwenkbare Überlaufkappe  
Placchetta di troppieno a ribalta

15

Obenliegendes Sieb  
Griglietta superiore

14



Zeichnung als pdf / dxf und Montageanleitung siehe:  
V. disegno in formato pdf / dxf e montaggio:  
suter.ch

## Optionales Zubehör/Accessori opzionali

312



**Resteschale gelocht**  
**Vaschetta forato**

CHF 106.– 40.000.912.00

**Resteschale ungelocht**  
**Vaschetta non forato**

CHF 106.– 40.001.289.00

**Schneidebrett aus Glas**  
**Tagliere in vetro**

CHF 151.– 40.000.909.00

**Schneidebrett aus Kunststoff**  
**Tagliere sintetico**

CHF 151.– 40.001.277.00

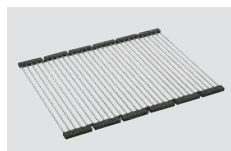

**Inox Pad**

CHF 125.– 40.001.138.00

Varianten: Der Austausch von Zugknöpfen erfolgt mittels Variantencode. Mehr Infos siehe Seite 395.  
Varianti: La sostituzione di pomoli avviene mediante codice variante. Per maggiori informazioni, vedere pag. 395.

Preis CHF/Prezzo in CHF

Modell Modello	Material Materiale	Ventil sFlow, Typ S Piletta sFlow, tipo S	Artikel-Nr. N. di articolo	Beckentiefe Profondità	Exkl. MWST IVA esclusa	Inkl. MWST IVA inclusa	VRG TRA		
Daneo DAN 40U	Edelstahl, matt Acciaio inox, opaco	18 / 10	3 1/2" TouchFlow	10.103.557.00	175 mm	A	983.–	1063.–	0.19
			3 1/2" Raumspar Salvaspazio	10.103.558.00	175 mm	A	785.–	849.–	
			3 1/2" Tipo	10.103.559.00	175 mm	A	744.–	804.–	

# Daneo: DAN 40U

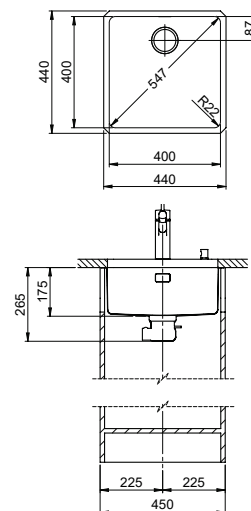

eFlow mit eControl  
eFlow con eControl

Schwenkbare Überlaufkappe  
Placchetta di troppopieno a ribalta

Desino: Verdeckter Ablauf mit untenliegendem Korb  
Desino: Scarico coperto con griglietta inferiore



Für eFlow Desino  
Per eFlow Desino



Für TouchFlow Desino, Raumspaar Desino und Tipo Desino  
Per TouchFlow Desino, Salvaspazio Desino e Tipo Desino



Für eFlow Desino, TouchFlow Desino, Raumspaar Desino und Tipo Desino  
Per eFlow Desino, TouchFlow Desino, Salvaspazio Desino e Tipo Desino

## Optionales Zubehör/Accessori opzionali

312



**Resteschale** gelocht  
**Vaschetta** forato

CHF 106.– 40.000.912.00



**Resteschale** ungelocht  
**Vaschetta** non forato

CHF 106.– 40.001.289.00



**Schneidebrett** aus Glas  
**Tagliere** in vetro

CHF 151.– 40.000.909.00



**Schneidebrett** aus Kunststoff  
**Tagliere** sintetico

CHF 151.– 40.001.277.00

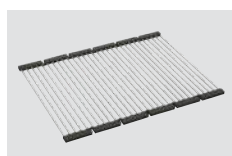

**Inox Pad**

CHF 125.– 40.001.138.00

Zeichnung als pdf / dxf und Montageanleitung siehe:  
V. disegno in formato pdf / dxf e montaggio:  
suter.ch

Varianten: Der Austausch von Zugknöpfen erfolgt mittels Variantencode. Mehr Infos siehe Seite 395.  
Varianti: La sostituzione di pomoli avviene mediante codice variante. Per maggiori informazioni, vedere pag. 395.

## Preis CHF/Prezzo in CHF

Modell Modello	Material Materiale	Ventil sFlow, Typ M Piletta sFlow, tipo M	Artikel-Nr. N. di articolo	Beckentiefe Profondità	Exkl. MWST IVA esclusa	Inkl. MWST IVA inclusa	VRG TRA		
<b>Daneo DAN 40U</b>	Edelstahl, matt Acciaio inox, opaco	18/10	3 1/2" eFlow Desino	10.104.665.00	175 mm	A	1250.–	1351.–	0.19
			3 1/2" TouchFlow Desino	10.104.634.00	175 mm	A	1135.–	1227.–	0.19
			3 1/2" Raumspaar Desino Salvaspazio Desino	10.104.635.00	175 mm	A	925.–	1000.–	
			3 1/2" Tipo Desino	10.105.606.00	175 mm	A	925.–	1000.–	

## Daneo: DAN 45U

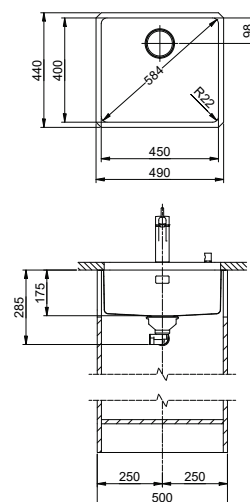

Schwenkbare Überlaufkappe  
Placchetta di troppieno a ribalta

15

Obenliegendes Sieb  
Griglietta superiore

14



Zeichnung als pdf / dxf und Montageanleitung siehe:  
V. disegno in formato pdf / dxf e montaggio:  
suter.ch

## Optionales Zubehör/Accessori opzionali

312



**Resteschale gelocht**  
**Vaschetta forato**

CHF 106.– 40.000.912.00

**Resteschale ungelocht**  
**Vaschetta non forato**

CHF 106.– 40.001.289.00

**Schneidebrett aus Glas**  
**Tagliere in vetro**

CHF 151.– 40.000.909.00

**Schneidebrett aus Kunststoff**  
**Tagliere sintetico**

CHF 151.– 40.001.277.00

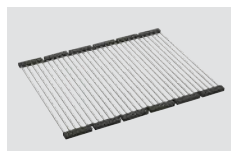
**Inox Pad**

CHF 125.– 40.001.138.00

Varianten: Der Austausch von Zugknöpfen erfolgt mittels Variantencode. Mehr Infos siehe Seite 395.  
Varianti: La sostituzione di pomoli avviene mediante codice variante. Per maggiori informazioni, vedere pag. 395.

Preis CHF/Prezzo in CHF

Modell Modello	Material Materiale	Ventil sFlow, Typ S Piletta sFlow, tipo S	Artikel-Nr. N. di articolo	Beckentiefe Profondità	Exkl. MWST IVA esclusa	Inkl. MWST IVA inclusa	VRG TRA		
Daneo DAN 45U	Edelstahl, matt Acciaio inox, opaco	18 / 10	3 1/2" TouchFlow	10.103.535.00	175 mm	A	993.–	1073.–	0.19
			3 1/2" Raumspar Salvaspazio	10.103.536.00	175 mm	A	795.–	859.–	
			3 1/2" Tipo	10.103.537.00	175 mm	A	754.–	815.–	

# Daneo: DAN 45U

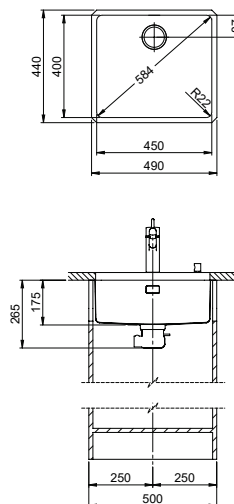

eFlow mit eControl  
eFlow con eControl

Schwenkbare Überlaufkappe  
Placchetta di troppopieno a ribalta

Desino: Verdeckter Ablauf mit untenliegendem Korb  
Desino: Scarico coperto con griglietta inferiore



Für eFlow Desino  
Per eFlow Desino



Für TouchFlow Desino, Raumspaar Desino und Tipo Desino  
Per TouchFlow Desino, Salvaspazio Desino e Tipo Desino



Für eFlow Desino, TouchFlow Desino, Raumspaar Desino und Tipo Desino  
Per eFlow Desino, TouchFlow Desino, Salvaspazio Desino e Tipo Desino

## Optionales Zubehör/Accessori opzionali

312



**Resteschale** gelocht  
**Vaschetta** forato

CHF 106.– 40.000.912.00



**Resteschale** ungelocht  
**Vaschetta** non forato

CHF 106.– 40.001.289.00



**Schneidebrett** aus Glas  
**Tagliere** in vetro

CHF 151.– 40.000.909.00



**Schneidebrett** aus Kunststoff  
**Tagliere** sintetico

CHF 151.– 40.001.277.00

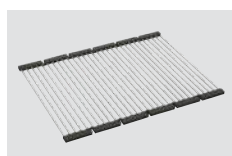

**Inox Pad**

CHF 125.– 40.001.138.00

Zeichnung als pdf / dxf und Montageanleitung siehe:  
V. disegno in formato pdf / dxf e montaggio:  
suter.ch

Varianten: Der Austausch von Zugknöpfen erfolgt mittels Variantencode. Mehr Infos siehe Seite 395.  
Varianti: La sostituzione di pomoli avviene mediante codice variante. Per maggiori informazioni, vedere pag. 395.

Preis CHF/Prezzo in CHF

Modell Modello	Material Materiale	Ventil sFlow, Typ M Piletta sFlow, tipo M	Artikel-Nr. N. di articolo	Beckentiefe Profondità	Exkl. MWST IVA esclusa	Inkl. MWST IVA inclusa	VRG TRA	
<b>Daneo DAN 45U</b>	Edelstahl, matt Acciaio inox, opaco	3 1/2" eFlow Desino	10.104.666.00	175 mm	A	1260.–	1362.–	0.19
		3 1/2" TouchFlow Desino	10.104.636.00	175 mm	A	1145.–	1238.–	0.19
		3 1/2" Raumspaar Desino Salvaspazio Desino	10.104.637.00	175 mm	A	935.–	1011.–	
		3 1/2" Tipo Desino	10.105.610.00	175 mm	A	935.–	1011.–	

Daneo: DAN 50U

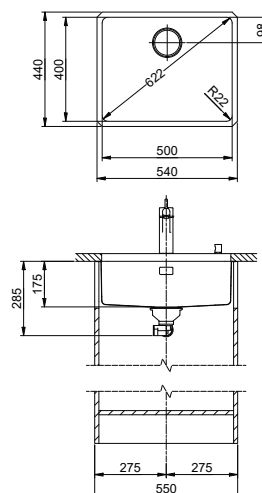

Schwenkbare Überlaufkappe  
Placchetta di troppieno a ribalta

Obenliegendes Sieb  
Griglietta superiore



Zeichnung als pdf / dxf und Montageanleitung siehe:  
V. disegno in formato pdf / dxf e montaggio:  
suter.ch

Optionales Zubehör/Accessori opzionali



**Resteschale gelocht** / **Vaschetta forato** CHF 106.– 40.000.912.00  
**Resteschale ungelocht** / **Vaschetta non forato** CHF 106.– 40.001.289.00  
**Schneidebrett aus Glas** / **Tagliere in vetro** CHF 151.– 40.000.909.00  
**Schneidebrett aus Kunststoff** / **Tagliere sintetico** CHF 151.– 40.001.277.00

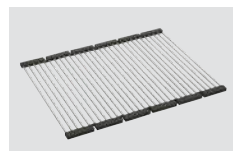

**Inox Pad**  
CHF 125.– 40.001.138.00

Varianten: Der Austausch von Zugknöpfen erfolgt mittels Variantencode. Mehr Infos siehe Seite 395.  
Varianti: La sostituzione di pomoli avviene mediante codice variante. Per maggiori informazioni, vedere pag. 395.

Preis CHF/Prezzo in CHF

Modell Modello	Material Materiale	Ventil sFlow, Typ S Piletta sFlow, tipo S	Artikel-Nr. N. di articolo	Beckentiefe Profondità	Exkl. MWST IVA esclusa	Inkl. MWST IVA inclusa	VRG TRA		
Daneo DAN 50U	Edelstahl, matt Acciaio inox, opaco	18 / 10	3 1/2" TouchFlow	10.103.541.00	175 mm	A	1196.–	1293.–	0.19
			3 1/2" Raumspar Salvaspazio	10.103.542.00	175 mm	A	998.–	1079.–	
			3 1/2" Tipo	10.103.543.00	175 mm	A	957.–	1035.–	

# Daneo: DAN 50U

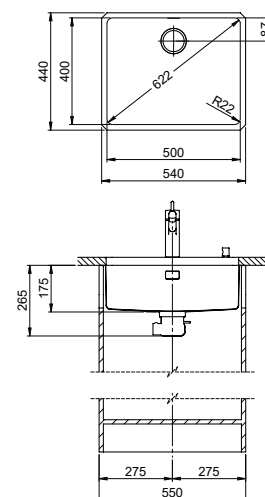

eFlow mit eControl  
eFlow con eControl

Schwenkbare Überlaufkappe  
Placchetta di troppopieno a ribalta

Desino: Verdeckter Ablauf mit untenliegendem Korb  
Desino: Scarico coperto con griglietta inferiore



Für eFlow Desino  
Per eFlow Desino



Für TouchFlow Desino, Raumspaar Desino und Tipo Desino  
Per TouchFlow Desino, Salvaspazio Desino e Tipo Desino



Für eFlow Desino, TouchFlow Desino, Raumspaar Desino und Tipo Desino  
Per eFlow Desino, TouchFlow Desino, Salvaspazio Desino e Tipo Desino

## Optionales Zubehör/Accessori opzionali



**Resteschale** gelocht  
**Vaschetta** forato

CHF 106.– 40.000.912.00



**Resteschale** ungelocht  
**Vaschetta** non forato

CHF 106.– 40.001.289.00



**Schneidebrett** aus Glas  
**Tagliere** in vetro

CHF 151.– 40.000.909.00



**Schneidebrett** aus Kunststoff  
**Tagliere** sintetico

CHF 151.– 40.001.277.00

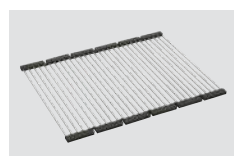

**Inox Pad**

CHF 125.– 40.001.138.00

Zeichnung als pdf / dxf und Montageanleitung siehe:  
V. disegno in formato pdf / dxf e montaggio:  
suter.ch

Varianten: Der Austausch von Zugknöpfen erfolgt mittels Variantencode. Mehr Infos siehe Seite 395.  
Varianti: La sostituzione di pomoli avviene mediante codice variante. Per maggiori informazioni, vedere pag. 395.

Preis CHF/Prezzo in CHF

Modell Modello	Material Materiale	Ventil sFlow, Typ M Piletta sFlow, tipo M	Artikel-Nr. N. di articolo	Beckentiefe Profondità	Exkl. MWST IVA esclusa	Inkl. MWST IVA inclusa	VRG TRA		
<b>Daneo DAN 50U</b>	Edelstahl, matt Acciaio inox, opaco	18/10	3 1/2" eFlow Desino	10.104.667.00	175 mm	A	1463.–	1582.–	0.19
			3 1/2" TouchFlow Desino	10.104.638.00	175 mm	A	1348.–	1457.–	0.19
			3 1/2" Raumspaar Desino Salvaspazio Desino	10.104.639.00	175 mm	A	1138.–	1230.–	
			3 1/2" Tipo Desino	10.105.614.00	175 mm	A	1138.–	1230.–	

## Daneo: DAN 55U

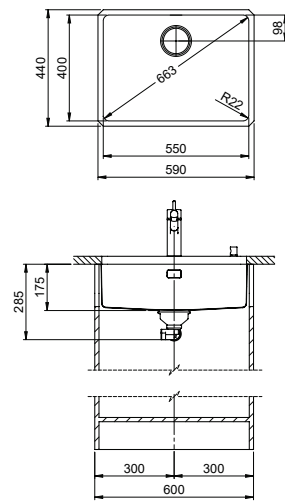

Schwenkbare Überlaufkappe  
Placchetta di troppieno a ribalta

15

Obenliegendes Sieb  
Griglietta superiore

14



Zeichnung als pdf / dxf und Montageanleitung siehe:  
V. disegno in formato pdf / dxf e montaggio:  
suter.ch

## Optionales Zubehör/Accessori opzionali

312



**Resteschale** gelocht  
**Vaschetta** forato

CHF 106.– 40.000.912.00

**Resteschale** ungelocht  
**Vaschetta** non forato

CHF 106.– 40.001.289.00

**Schneidebrett** aus Glas  
**Tagliere** in vetro

CHF 151.– 40.000.909.00

**Schneidebrett** aus Kunststoff  
**Tagliere** sintetico

CHF 151.– 40.001.277.00

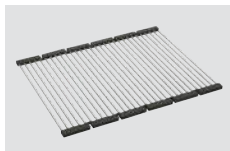

**Inox Pad**

CHF 125.– 40.001.138.00



Varianten: Der Austausch von Zugknöpfen erfolgt mittels Variantencode. Mehr Infos siehe Seite 395.  
Varianti: La sostituzione di pomoli avviene mediante codice variante. Per maggiori informazioni, vedere pag. 395.

Preis CHF/Prezzo in CHF

Modell Modello	Material Materiale	Ventil sFlow, Typ S Piletta sFlow, tipo S	Artikel-Nr. N. di articolo	Beckentiefe Profondità	Exkl. MWST IVA esclusa	Inkl. MWST IVA inclusa	VRG TRA		
Daneo DAN 55U	Edelstahl, matt Acciaio inox, opaco	18 / 10	3 1/2" TouchFlow	10.103.547.00	175 mm	A	1297.–	1402.–	0.19
			3 1/2" Raumspar Salvaspazio	10.103.548.00	175 mm	A	1099.–	1188.–	
			3 1/2" Tipo	10.103.549.00	175 mm	A	1058.–	1144.–	

# Daneo: DAN 55U

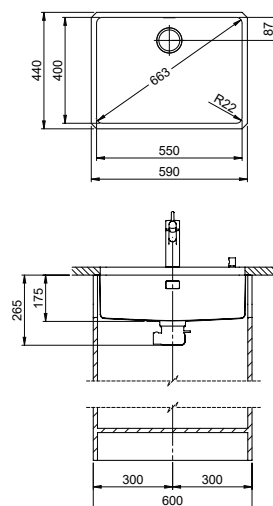

eFlow mit eControl  
eFlow con eControl

Schwenkbare Überlaufkappe  
Placchetta di troppopieno a ribalta

Desino: Verdeckter Ablauf mit untenliegendem Korb  
Desino: Scarico coperto con griglietta inferiore



Für eFlow Desino  
Per eFlow Desino



Für TouchFlow Desino, Raumspaar Desino und Tipo Desino  
Per TouchFlow Desino, Salvaspazio Desino e Tipo Desino



Für eFlow Desino, TouchFlow Desino, Raumspaar Desino und Tipo Desino  
Per eFlow Desino, TouchFlow Desino, Salvaspazio Desino e Tipo Desino

## Optionales Zubehör/Accessori opzionali

312



**Resteschale** gelocht  
**Vaschetta** forato

CHF 106.– 40.000.912.00



**Resteschale** ungelocht  
**Vaschetta** non forato

CHF 106.– 40.001.289.00



**Schneidebrett** aus Glas  
**Tagliere** in vetro

CHF 151.– 40.000.909.00



**Schneidebrett** aus Kunststoff  
**Tagliere** sintetico

CHF 151.– 40.001.277.00

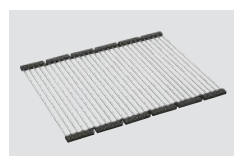

**Inox Pad**

CHF 125.– 40.001.138.00

Zeichnung als pdf / dxf und Montageanleitung siehe:  
V. disegno in formato pdf / dxf e montaggio:  
suter.ch

Varianten: Der Austausch von Zugknöpfen erfolgt mittels Variantencode. Mehr Infos siehe Seite 395.  
Varianti: La sostituzione di pomoli avviene mediante codice variante. Per maggiori informazioni, vedere pag. 395.

Preis CHF/Prezzo in CHF

Modell Modello	Material Materiale	Ventil sFlow, Typ M Piletta sFlow, tipo M	Artikel-Nr. N. di articolo	Beckentiefe Profondità	Exkl. MWST IVA esclusa	Inkl. MWST IVA inclusa	VRG TRA		
<b>Daneo DAN 55U</b>	Edelstahl, matt Acciaio inox, opaco	18/10	3 1/2" eFlow Desino	10.104.668.00	175 mm	A	1564.–	1691.–	0.19
			3 1/2" TouchFlow Desino	10.104.640.00	175 mm	A	1449.–	1566.–	0.19
			3 1/2" Raumspaar Desino Salvaspazio Desino	10.104.641.00	175 mm	A	1239.–	1339.–	
			3 1/2" Tipo Desino	10.105.618.00	175 mm	A	1239.–	1339.–	

## Vantis: V 34U

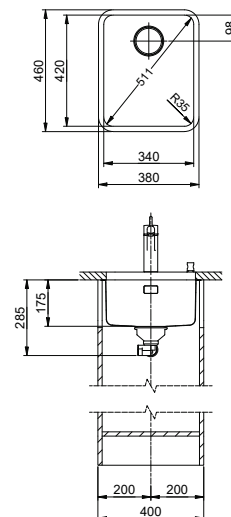

Schwenkbare Überlaufkappe  
Placchetta di troppieno a ribalta

Obenliegendes Sieb  
Griglietta superiore



Zeichnung als pdf / dxf und Montageanleitung siehe:  
V. disegno in formato pdf / dxf e montaggio:  
suter.ch

## Optionales Zubehör/Accessori opzionali



**Resteschale gelocht**  
**Vaschetta forato**  
CHF 106.– 40.000.914.00



**Resteschale ungelocht**  
**Vaschetta non forato**  
CHF 106.– 40.001.290.00



**Schneidebrett aus Glas**  
**Tagliere in vetro**  
CHF 151.– 40.000.915.00



**Holz-Schneidebrett aus Nussbaum**  
**Tagliere in legno di noce**  
CHF 151.– 40.001.147.00

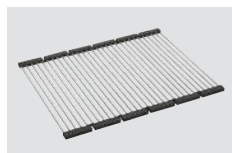

**Inox Pad**  
CHF 125.– 40.001.138.00

Varianten: Der Austausch von Zugknöpfen erfolgt mittels Variantencode. Mehr Infos siehe Seite 395.  
Varianti: La sostituzione di pomoli avviene mediante codice variante. Per maggiori informazioni, vedere pag. 395.

Preis CHF/Prezzo in CHF

Modell Modello	Material Materiale	Ventil sFlow, Typ S Piletta sFlow, Typ S	Artikel-Nr. N. di articolo	Beckentiefe Profondità	Exkl. MWST IVA esclusa	Inkl. MWST IVA inclusa	VRG TRA		
Vantis V 34U	Edelstahl, matt Acciaio inox, opaco	18 / 10	3 1/2" TouchFlow	10.103.877.00	175 mm	A	916.–	990.–	0.19
			3 1/2" Raumspar Salvaspazio	10.103.878.00	175 mm	A	718.–	776.–	
			3 1/2" Tipo	10.103.879.00	175 mm	A	669.–	723.–	

# Vantis: V 34U

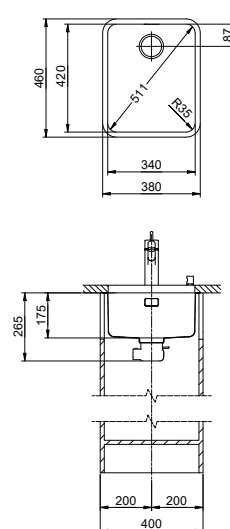

eFlow mit eControl  
eFlow con eControl

Schwenkbare Überlaufkappe  
Placchetta di troppopieno a ribalta

Desino: Verdeckter Ablauf mit untenliegendem Korb  
Desino: Scarico coperto con griglietta inferiore



Für eFlow Desino  
Per eFlow Desino



Für TouchFlow Desino, Raumspar Desino und Tipo Desino  
Per TouchFlow Desino, Salvaspazio Desino e Tipo Desino



Für eFlow Desino, TouchFlow Desino, Raumspar Desino und Tipo Desino  
Per eFlow Desino, TouchFlow Desino, Salvaspazio Desino e Tipo Desino



## Optionales Zubehör/Accessori opzionali

312



**Resteschale** gelocht  
**Vaschetta** forato

CHF 106.– 40.000.914.00



**Resteschale** ungelocht  
**Vaschetta** non forato

CHF 106.– 40.001.290.00



**Schneidebrett** aus Glas  
**Tagliere** in vetro

CHF 151.– 40.000.915.00



**Holz-Schneidebrett** aus Nussbaum  
**Tagliere** in legno di noce

CHF 151.– 40.001.147.00

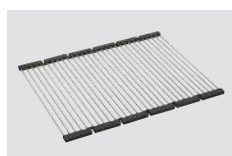

**Inox Pad**

CHF 125.– 40.001.138.00

Zeichnung als pdf / dxf und Montageanleitung siehe:  
V. disegno in formato pdf / dxf e montaggio:  
suter.ch

Varianten: Der Austausch von Zugknöpfen erfolgt mittels Variantencode. Mehr Infos siehe Seite 395.  
Varianti: La sostituzione di pomoli avviene mediante codice variante. Per maggiori informazioni, vedere pag. 395.

## Preis CHF/Prezzo in CHF

Modell Modello	Material Materiale	Ventil sFlow, Typ M Piletta sFlow, tipo M	Artikel-Nr. N. di articolo	Beckentiefe Profondità	Exkl. MWST IVA esclusa	Inkl. MWST IVA inclusa	VRG TRA		
<b>Vantis V 34U</b>	Edelstahl, matt Acciaio inox, opaco	18/10	3 1/2" eFlow Desino	10.105.254.00	175 mm	A	1183.–	1279.–	0.19
			3 1/2" TouchFlow Desino	10.105.255.00	175 mm	A	1068.–	1155.–	0.19
			3 1/2" Raumspar Desino Salvaspazio Desino	10.105.256.00	175 mm	A	858.–	927.–	
			3 1/2" Tipo Desino	10.105.623.00	175 mm	A	858.–	927.–	

Vantis: V 40U

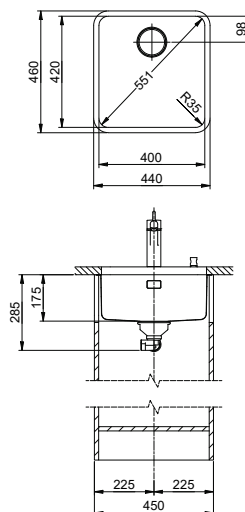

Schwenkbare Überlaufkappe  
Placchetta di troppieno a ribalta

Obenliegendes Sieb  
Griglietta superiore

14



Zeichnung als pdf / dxf und Montageanleitung siehe:  
V. disegno in formato pdf / dxf e montaggio:  
suter.ch

Optionales Zubehör/Accessori opzionali

312



**Resteschale gelocht**  
**Vaschetta forato**  
CHF 106.– 40.000.914.00

**Resteschale ungelocht**  
**Vaschetta non forato**  
CHF 106.– 40.001.290.00

**Schneidebrett aus Glas**  
**Tagliere in vetro**  
CHF 151.– 40.000.915.00

**Holz-Schneidebrett aus Nussbaum**  
**Tagliere in legno di noce**  
CHF 151.– 40.001.147.00

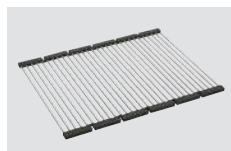

**Inox Pad**  
CHF 125.– 40.001.138.00

Varianten: Der Austausch von Zugknöpfen erfolgt mittels Variantencode. Mehr Infos siehe Seite 395.  
Varianti: La sostituzione di pomoli avviene mediante codice variante. Per maggiori informazioni, vedere pag. 395.

Preis CHF/Prezzo in CHF

Modell Modello	Material Materiale	Ventil sFlow, Typ S Piletta sFlow, Typ S	Artikel-Nr. N. di articolo	Beckentiefe Profondità	Exkl. MWST IVA esclusa	Inkl. MWST IVA inclusa	VRG TRA		
Vantis V 40U	Edelstahl, matt Acciaio inox, opaco	18 / 10	3 1/2" TouchFlow	10.103.883.00	175 mm	A	926.–	1001.–	0.19
			3 1/2" Raumspar Salvaspazio	10.103.884.00	175 mm	A	728.–	787.–	
			3 1/2" Tipo	10.103.885.00	175 mm	A	679.–	734.–	

# Vantis: V 40U

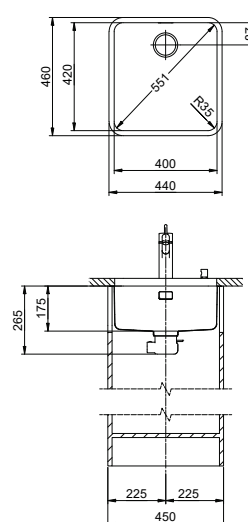

eFlow mit eControl  
eFlow con eControl

Schwenkbare Überlaufkappe  
Placchetta di troppopieno a ribalta

Desino: Verdeckter Ablauf mit untenliegendem Korb  
Desino: Scarico coperto con griglietta inferiore



Für eFlow Desino  
Per eFlow Desino



Für TouchFlow Desino, Raumspar Desino und Tipo Desino  
Per TouchFlow Desino, Salvaspazio Desino e Tipo Desino



Für eFlow Desino, TouchFlow Desino, Raumspar Desino und Tipo Desino  
Per eFlow Desino, TouchFlow Desino, Salvaspazio Desino e Tipo Desino



## Optionales Zubehör/Accessori opzionali

312



**Resteschale** gelocht  
**Vaschetta** forato

CHF 106.– 40.000.914.00



**Resteschale** ungelocht  
**Vaschetta** non forato

CHF 106.– 40.001.290.00



**Schneidebrett** aus Glas  
**Tagliere** in vetro

CHF 151.– 40.000.915.00



**Holz-Schneidebrett** aus Nussbaum  
**Tagliere** in legno di noce

CHF 151.– 40.001.147.00

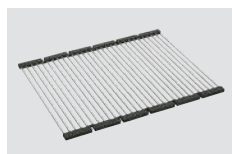

**Inox Pad**

CHF 125.– 40.001.138.00

Zeichnung als pdf / dxf und Montageanleitung siehe:  
V. disegno in formato pdf / dxf e montaggio:  
suter.ch

Varianten: Der Austausch von Zugknöpfen erfolgt mittels Variantencode. Mehr Infos siehe Seite 395.  
Varianti: La sostituzione di pomoli avviene mediante codice variante. Per maggiori informazioni, vedere pag. 395.

## Preis CHF/Prezzo in CHF

Modell Modello	Material Materiale	Ventil sFlow, Typ M Piletta sFlow, tipo M	Artikel-Nr. N. di articolo	Beckentiefe Profondità	Exkl. MWST IVA esclusa	Inkl. MWST IVA inclusa	VRG TRA	
<b>Vantis V 40U</b>	Edelstahl, matt Acciaio inox, opaco	3 1/2" eFlow Desino	10.105.257.00	175 mm	A	1193.–	1290.–	0.19
		3 1/2" TouchFlow Desino	10.105.258.00	175 mm	A	1078.–	1165.–	0.19
		3 1/2" Raumspar Desino Salvaspazio Desino	10.105.259.00	175 mm	A	868.–	938.–	
		3 1/2" Tipo Desino	10.105.627.00	175 mm	A	868.–	938.–	

# Vantis: V 45U

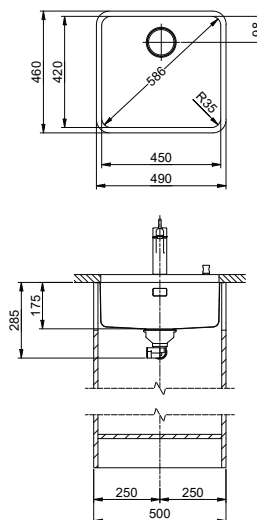

Schwenkbare Überlaufkappe  
Placchetta di troppieno a ribalta

Obenliegendes Sieb  
Griglietta superiore

14



Zeichnung als pdf / dxf und Montageanleitung siehe:  
V. disegno in formato pdf / dxf e montaggio:  
suter.ch

## Optionales Zubehör/Accessori opzionali

312



**Resteschale gelocht**  
**Vaschetta forata**  
CHF 106.– 40.000.914.00

**Resteschale ungelocht**  
**Vaschetta non forata**  
CHF 106.– 40.001.290.00

**Schneidebrett aus Glas**  
**Tagliere in vetro**  
CHF 151.– 40.000.915.00

**Holz-Schneidebrett aus Nussbaum**  
**Tagliere in legno di noce**  
CHF 151.– 40.001.147.00

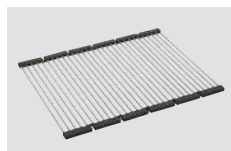

**Inox Pad**  
CHF 125.– 40.001.138.00

Varianten: Der Austausch von Zugknöpfen erfolgt mittels Variantencode. Mehr Infos siehe Seite 395.  
Varianti: La sostituzione di pomoli avviene mediante codice variante. Per maggiori informazioni, vedere pag. 395.

Preis CHF/Prezzo in CHF

Modell Modello	Material Materiale	Ventil sFlow, Typ S Piletta sFlow, Typ S	Artikel-Nr. N. di articolo	Beckentiefe Profondità	Exkl. MWST IVA esclusa	Inkl. MWST IVA inclusa	VRG TRA		
Vantis V 45U	Edelstahl, matt Acciaio inox, opaco	18 / 10	3 1/2" TouchFlow	10.103.889.00	175 mm	A	938.–	1014.–	0.19
			3 1/2" Raumspar Salvaspazio	10.103.890.00	175 mm	A	740.–	800.–	
			3 1/2" Tipo	10.103.891.00	175 mm	A	691.–	747.–	

# Vantis: V 45U

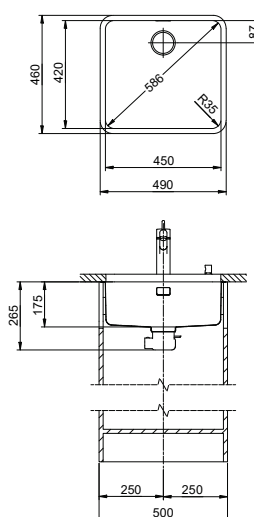

eFlow mit eControl  
eFlow con eControl

Schwenkbare Überlaufkappe  
Placchetta di troppopieno a ribalta

Desino: Verdeckter Ablauf mit untenliegendem Korb  
Desino: Scarico coperto con griglietta inferiore



Für eFlow Desino  
Per eFlow Desino



Für TouchFlow Desino, Raumspaar Desino und Tipo Desino  
Per TouchFlow Desino, Salvaspazio Desino e Tipo Desino



Für eFlow Desino, TouchFlow Desino, Raumspaar Desino und Tipo Desino  
Per eFlow Desino, TouchFlow Desino, Salvaspazio Desino e Tipo Desino

## Optionales Zubehör/Accessori opzionali

312



**Resteschale** gelocht  
**Vaschetta** forato

CHF 106.– 40.000.914.00



**Resteschale** ungelocht  
**Vaschetta** non forato

CHF 106.– 40.001.290.00



**Schneidebrett** aus Glas  
**Tagliere** in vetro

CHF 151.– 40.000.915.00



**Holz-Schneidebrett** aus Nussbaum  
**Tagliere** in legno di noce

CHF 151.– 40.001.147.00

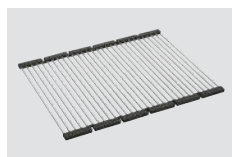

**Inox Pad**

CHF 125.– 40.001.138.00

Zeichnung als pdf / dxf und Montageanleitung siehe:  
V. disegno in formato pdf / dxf e montaggio:  
suter.ch

Varianten: Der Austausch von Zugknöpfen erfolgt mittels Variantencode. Mehr Infos siehe Seite 395.  
Varianti: La sostituzione di pomoli avviene mediante codice variante. Per maggiori informazioni, vedere pag. 395.

## Preis CHF/Prezzo in CHF

Modell Modello	Material Materiale	Ventil sFlow, Typ M Piletta sFlow, tipo M	Artikel-Nr. N. di articolo	Beckentiefe Profondità	Exkl. MWST IVA esclusa	Inkl. MWST IVA inclusa	VRG TRA	
<b>Vantis V 45U</b>	Edelstahl, matt Acciaio inox, opaco	3 1/2" eFlow Desino	10.105.267.00	175 mm	A	1205.–	1303.–	0.19
		3 1/2" TouchFlow Desino	10.105.204.00	175 mm	A	1090.–	1178.–	0.19
		3 1/2" Raumspaar Desino Salvaspazio Desino	10.105.205.00	175 mm	A	880.–	951.–	
		3 1/2" Tipo Desino	10.105.631.00	175 mm	A	880.–	951.–	

## Vantis: V 50-42U

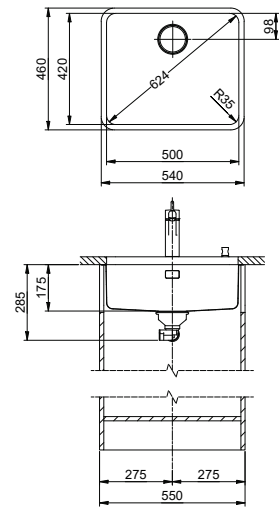

Schwenkbare Überlaufkappe  
Placchetta di troppieno a ribalta

15

Obenliegendes Sieb  
Griglietta superiore

14



Zeichnung als pdf / dxf und Montageanleitung siehe:  
V. disegno in formato pdf / dxf e montaggio:  
suter.ch

## Optionales Zubehör/Accessori opzionali

312



**Resteschale gelocht**  
**Vaschetta forato**

CHF 106.– 40.000.914.00



**Resteschale ungelocht**  
**Vaschetta non forato**

CHF 106.– 40.001.290.00



**Schneidebrett aus Glas**  
**Tagliere in vetro**

CHF 151.– 40.000.915.00



**Holz-Schneidebrett aus Nussbaum**  
**Tagliere in legno di noce**

CHF 151.– 40.001.147.00

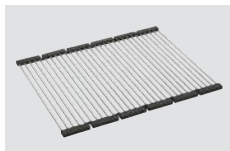

**Inox Pad**

CHF 125.– 40.001.138.00

Varianten: Der Austausch von Zugknöpfen erfolgt mittels Variantencode. Mehr Infos siehe Seite 395.  
Varianti: La sostituzione di pomoli avviene mediante codice variante. Per maggiori informazioni, vedere pag. 395.

Preis CHF/Prezzo in CHF

Modell Modello	Material Materiale	Ventil sFlow, Typ S Piletta sFlow, Typ S	Artikel-Nr. N. di articolo	Beckentiefe Profondità	Exkl. MWST IVA esclusa	Inkl. MWST IVA inclusa	VRG TRA
Vantis V 50-42U	Edelstahl, matt Acciaio inox, opaco	3 1/2" TouchFlow	10.103.895.00	175 mm	1140.–	1232.–	0.19
		3 1/2" Raumspar Salvaspazio	10.103.896.00	175 mm	942.–	1018.–	
		3 1/2" Tipo	10.103.897.00	175 mm	893.–	965.–	

# Vantis: V 50-42U

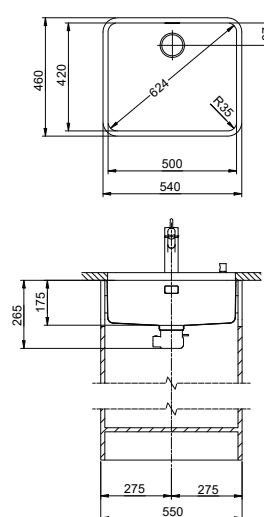

eFlow mit eControl  
eFlow con eControl

Schwenkbare Überlaufkappe  
Placchetta di troppopieno a ribalta

Desino: Verdeckter Ablauf mit untenliegendem Korb  
Desino: Scarico coperto con griglietta inferiore



Für eFlow Desino  
Per eFlow Desino



Für TouchFlow Desino, Raumspar Desino und Tipo Desino  
Per TouchFlow Desino, Salvaspazio Desino e Tipo Desino



Für eFlow Desino, TouchFlow Desino, Raumspar Desino und Tipo Desino  
Per eFlow Desino, TouchFlow Desino, Salvaspazio Desino e Tipo Desino



## Optionales Zubehör/Accessori opzionali

312



**Resteschale** gelocht  
**Vaschetta** forato

CHF 106.– 40.000.914.00



**Resteschale** ungelocht  
**Vaschetta** non forato

CHF 106.– 40.001.290.00



**Schneidebrett** aus Glas  
**Tagliere** in vetro

CHF 151.– 40.000.915.00



**Holz-Schneidebrett** aus Nussbaum  
**Tagliere** in legno di noce

CHF 151.– 40.001.147.00

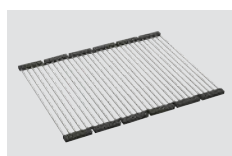

**Inox Pad**

CHF 125.– 40.001.138.00

Zeichnung als pdf / dxf und Montageanleitung siehe:  
V. disegno in formato pdf / dxf e montaggio:  
suter.ch

Varianten: Der Austausch von Zugknöpfen erfolgt mittels Variantencode. Mehr Infos siehe Seite 395.  
Varianti: La sostituzione di pomoli avviene mediante codice variante. Per maggiori informazioni, vedere pag. 395.

Preis CHF/Prezzo in CHF

Modell Modello	Material Materiale	Ventil sFlow, Typ M Piletta sFlow, tipo M	Artikel-Nr. N. di articolo	Beckentiefe Profondità	Exkl. MWST IVA esclusa	Inkl. MWST IVA inclusa	VRG TRA	
<b>Vantis V 50-42U</b>	Edelstahl, matt Acciaio inox, opaco	3 1/2" eFlow Desino	10.105.268.00	175 mm	A	1407.–	1521.–	0.19
		3 1/2" TouchFlow Desino	10.105.206.00	175 mm	A	1292.–	1397.–	0.19
		3 1/2" Raumspar Desino Salvaspazio Desino	10.105.207.00	175 mm	A	1082.–	1170.–	
		3 1/2" Tipo Desino	10.105.635.00	175 mm	A	1082.–	1170.–	

## Vantis: V 50-35U + V 11U

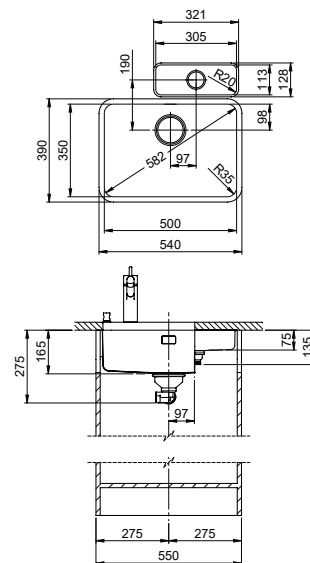

Schwenkbare Überlaufcappe  
Placchetta di troppopieno a ribalta

Obenliegendes Sieb  
Griglietta superiore



Zeichnung als pdf / dxf und Montageanleitung siehe:  
V. disegno in formato pdf / dxf e montaggio:  
suter.ch

## Optionales Zubehör/Accessori opzionali

312



Resteschale gelocht  
Vaschetta forato

CHF 106.– 40.000.916.00

Varianten: Der Austausch von Zugknöpfen erfolgt mittels Variantencode. Mehr Infos siehe Seite 395.  
Varianti: La sostituzione di pomoli avviene mediante codice variante. Per maggiori informazioni, vedere pag. 395.

Preis CHF/Prezzo in CHF

Modell Modello	Material Materiale	Ventil sFlow, Typ S Piletta sFlow, Typ S	Artikel-Nr. N. di articolo	Beckentiefe Profondità	Exkl. MWST IVA esclusa	Inkl. MWST IVA inclusa	VRG TRA		
Vantis V 50-35U	Edelstahl, matt Acciaio inox, opaco	18/10	3 1/2" TouchFlow	10.103.907.00	165 mm	A	936.–	1012.–	0.19
			3 1/2" Raumspar Salvaspazio	10.103.908.00	165 mm	A	738.–	798.–	
			3 1/2" Tipo	10.103.909.00	165 mm	A	689.–	745.–	
Vantis V 11U	Edelstahl, matt Acciaio inox, opaco	18/10	1 1/2" Stopfen A tappo	10.103.873.00	75 mm	A	567.–	613.–	
Vantis V 50-35U + Vantis V 11U	Edelstahl, matt Acciaio inox, opaco	18/10	3 1/2" TouchFlow +	10.103.913.00	165 mm 75 mm	A	1464.–	1583.–	0.19
			1 1/2" Stopfen A tappo						
			3 1/2" Raumspar + Salvaspazio	10.103.914.00	165 mm 75 mm	A	1266.–	1369.–	
			1 1/2" Stopfen A tappo						
3 1/2" Tipo +	10.103.915.00	165 mm 75 mm	A	1217.–	1316.–				
1 1/2" Stopfen A tappo									

# Vantis: V 50-35U + V 11U

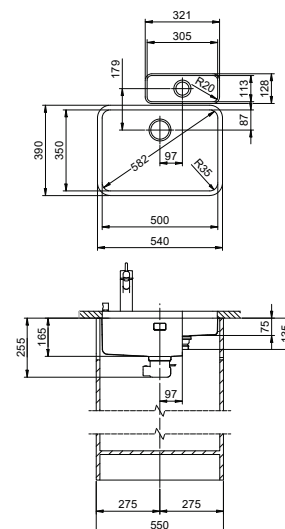

eFlow mit eControl  
eFlow con eControl

Schwenkbare Überlaufkappe  
Placchetta di troppopieno a ribalta

Desino: Verdeckter Ablauf mit untenliegendem Korb  
Desino: Scarico coperto con griglietta inferiore



Für eFlow Desino  
Per eFlow Desino



Für TouchFlow Desino, Raumspaar Desino und Tipo Desino  
Per TouchFlow Desino, Salvaspazio Desino e Tipo Desino



Für eFlow Desino, TouchFlow Desino, Raumspaar Desino und Tipo Desino  
Per eFlow Desino, TouchFlow Desino, Salvaspazio Desino e Tipo Desino



Zeichnung als pdf / dxf und Montageanleitung siehe:  
V. disegno in formato pdf / dxf e montaggio:  
suter.ch

Varianten: Der Austausch von Zugknöpfen erfolgt mittels Variantencode. Mehr Infos siehe Seite 395.  
Varianti: La sostituzione di pomoli avviene mediante codice variante. Per maggiori informazioni, vedere pag.395.

## Preis CHF/Prezzo in CHF

Modell Modello	Material Materiale	Ventil sFlow, Typ M Piletta sFlow, tipo M	Artikel-Nr. N. di articolo	Beckentiefe Profondità	Exkl. MWST IVA esclusa	Inkl. MWST IVA inclusa	VRG TRA		
<b>Vantis V 50-35U</b>	Edelstahl, matt Acciaio inox, opaco	18/10	3 1/2" eFlow Desino	10.105.260.00	165 mm	A	1203.–	1300.–	0.19
			3 1/2" TouchFlow Desino	10.105.261.00	165 mm	A	1088.–	1176.–	0.19
			3 1/2" Raumspaar Desino Salvaspazio	10.105.262.00	165 mm	A	878.–	949.–	
			3 1/2" Tipo Desino	10.105.639.00	165 mm	A	878.–	949.–	
<b>Vantis V 11U</b>	Edelstahl, matt Acciaio inox, opaco	18/10	1 1/2" Stopfen A tappo	10.103.873.00	75 mm	A	567.–	613.–	
<b>Vantis V 50-35U + Vantis V 11U</b>	Edelstahl, matt Acciaio inox, opaco	18/10	3 1/2" eFlow Desino + 1 1/2" Stopfen A tappo	10.105.263.00	165 mm 75 mm	A	1727.–	1867.–	0.19
			3 1/2" TouchFlow Desino + 1 1/2" Stopfen A tappo	10.105.264.00	165 mm 75 mm	A	1612.–	1743.–	0.19
			3 1/2" Raumspaar Desino + Salvaspazio 1 1/2" Stopfen A tappo	10.105.265.00	165 mm 75 mm	A	1402.–	1516.–	
			3 1/2" Tipo Desino + 1 1/2" Stopfen A tappo	10.105.643.00	165 mm 75 mm	A	1402.–	1516.–	

Vantis: V 55U

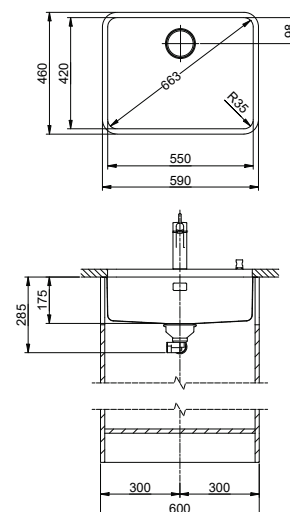

Schwenkbare Überlaufkappe  
Placchetta di troppopieno a ribalta

Obenliegendes Sieb  
Griglietta superiore

14



Zeichnung als pdf / dxf und Montageanleitung siehe:  
V. disegno in formato pdf / dxf e montaggio:  
suter.ch

Optionales Zubehör/Accessori opzionali

312



**Resteschale gelocht**  
**Vaschetta forato**  
CHF 106.– 40.000.914.00



**Resteschale ungelocht**  
**Vaschetta non forato**  
CHF 106.– 40.001.290.00



**Schneidebrett aus Glas**  
**Tagliere in vetro**  
CHF 151.– 40.000.915.00



**Holz-Schneidebrett aus Nussbaum**  
**Tagliere in legno di noce**  
CHF 151.– 40.001.147.00

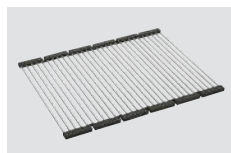

**Inox Pad**  
CHF 125.– 40.001.138.00

Varianten: Der Austausch von Zugknöpfen erfolgt mittels Variantencode. Mehr Infos siehe Seite 395.  
Varianti: La sostituzione di pomoli avviene mediante codice variante. Per maggiori informazioni, vedere pag. 395.

Preis CHF/Prezzo in CHF

Modell Modello	Material Materiale	Ventil sFlow, Typ S Piletta sFlow, Typ S	Artikel-Nr. N. di articolo	Beckentiefe Profondità	Exkl. MWST IVA esclusa	Inkl. MWST IVA inclusa	VRG TRA		
Vantis V 55U	Edelstahl, matt Acciaio inox, opaco	18 / 10	3 1/2" TouchFlow	10.103.901.00	175 mm	A	1273.–	1376.–	0.19
			3 1/2" Raumspar Salvaspazio	10.103.902.00	175 mm	A	1075.–	1162.–	
			3 1/2" Tipo	10.103.903.00	175 mm	A	1026.–	1109.–	

# Vantis: V 55U

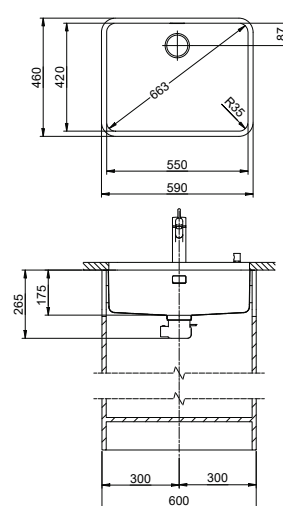

eFlow mit eControl  
eFlow con eControl

Schwenkbare Überlaufkappe  
Placchetta di troppopieno a ribalta

Desino: Verdeckter Ablauf mit untenliegendem Korb  
Desino: Scarico coperto con griglietta inferiore



Für eFlow Desino  
Per eFlow Desino



Für TouchFlow Desino, Raumspaar Desino und Tipo Desino  
Per TouchFlow Desino, Salvaspazio Desino e Tipo Desino



Für eFlow Desino, TouchFlow Desino, Raumspaar Desino und Tipo Desino  
Per eFlow Desino, TouchFlow Desino, Salvaspazio Desino e Tipo Desino

## Optionales Zubehör/Accessori opzionali

312



**Resteschale** gelocht  
**Vaschetta** forato

CHF 106.– 40.000.914.00



**Resteschale** ungelocht  
**Vaschetta** non forato

CHF 106.– 40.001.290.00



**Schneidebrett** aus Glas  
**Tagliere** in vetro

CHF 151.– 40.000.915.00



**Holz-Schneidebrett** aus Nussbaum  
**Tagliere** in legno di noce

CHF 151.– 40.001.147.00

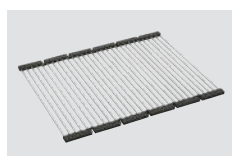

**Inox Pad**

CHF 125.– 40.001.138.00

Zeichnung als pdf / dxf und Montageanleitung siehe:  
V. disegno in formato pdf / dxf e montaggio:  
suter.ch

Varianten: Der Austausch von Zugknöpfen erfolgt mittels Variantencode. Mehr Infos siehe Seite 395.  
Varianti: La sostituzione di pomoli avviene mediante codice variante. Per maggiori informazioni, vedere pag. 395.

## Preis CHF/Prezzo in CHF

Modell Modello	Material Materiale	Ventil sFlow, Typ M Piletta sFlow, tipo M	Artikel-Nr. N. di articolo	Beckentiefe Profondità	Exkl. MWST IVA esclusa	Inkl. MWST IVA inclusa	VRG TRA		
<b>Vantis V 55U</b>	Edelstahl, matt Acciaio inox, opaco	18/10	3 1/2" eFlow Desino	10.105.269.00	175 mm	A	1540.–	1665.–	0.19
			3 1/2" TouchFlow Desino	10.105.208.00	175 mm	A	1425.–	1540.–	0.19
			3 1/2" Raumspaar Desino Salvaspazio Desino	10.105.209.00	175 mm	A	1215.–	1313.–	
			3 1/2" Tipo Desino	10.105.647.00	175 mm	A	1215.–	1313.–	

# Vantis: VG 45U Green

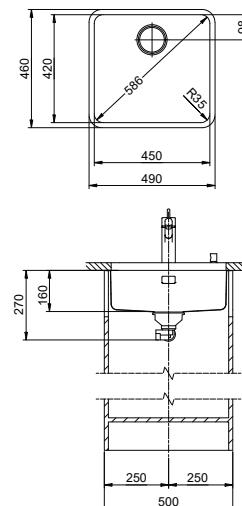

Schwenkbare Überlaufkappe  
Placchetta di troppopieno a ribalta

Obenliegendes Sieb  
Griglietta superiore



Zeichnung als pdf / dxf und Montageanleitung siehe:  
V. disegno in formato pdf / dxf e montaggio:  
suter.ch

## Optionales Zubehör / Accessori opzionali



**Resteschale gelocht** / **Vaschetta forata** CHF 106.– 40.000.914.00  
**Resteschale ungelocht** / **Vaschetta non forata** CHF 106.– 40.001.290.00  
**Schneidebrett aus Glas** / **Tagliere in vetro** CHF 151.– 40.000.915.00  
**Holz-Schneidebrett aus Nussbaum** / **Tagliere in legno di noce** CHF 151.– 40.001.147.00

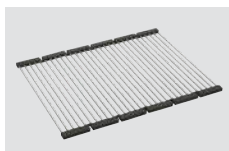

**Innox Pad**  
CHF 125.– 40.001.138.00

Green Line ist eine eigenständige auf Nachhaltigkeit ausgerichtete Produktausführung.  
Green Line è una versione di prodotto autonoma calibrata sulla sostenibilità.

Varianten: Der Austausch von Zugknöpfen erfolgt mittels Variantencode. Mehr Infos siehe Seite 395.  
Varianti: La sostituzione di pomoli avviene mediante codice variante. Per maggiori informazioni, vedere pag. 395.

Preis CHF / Prezzo in CHF

Modell Modello	Material Materiale	Ventil sFlow, Typ S Piletta sFlow, Typ S	Artikel-Nr. N. di articolo	Beckentiefe Profondità	Exkl. MWST IVA esclusa	Inkl. MWST IVA inclusa	VRG TRA		
Vantis VG 45U Green	Edelstahl, matt Acciaio inox, opaco	18 / 10	3 1/2" TouchFlow	10.105.762.00	160 mm	A	998.–	1079.–	0.19
			3 1/2" Raumspar Salvaspazio	10.105.763.00	160 mm	A	800.–	865.–	
			3 1/2" Tipo	10.105.764.00	160 mm	A	751.–	812.–	

# Vantis: VG 50-42U Green

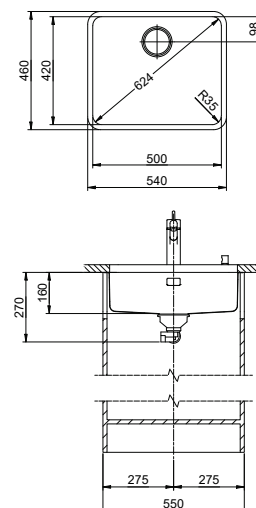

Schwenkbare Überlaufkappe  
Placchetta di troppieno a ribalta

Obenliegendes Sieb  
Griglietta superiore

14



Zeichnung als pdf / dxf und Montageanleitung siehe:  
V. disegno in formato pdf / dxf e montaggio:  
suter.ch

## Optionales Zubehör/Accessori opzionali

312



**Resteschale gelocht**  
**Vaschetta forata**  
CHF 106.– 40.000.914.00



**Resteschale ungelocht**  
**Vaschetta non forata**  
CHF 106.– 40.001.290.00



**Schneidebrett aus Glas**  
**Tagliere in vetro**  
CHF 151.– 40.000.915.00



**Holz-Schneidebrett aus Nussbaum**  
**Tagliere in legno di noce**  
CHF 151.– 40.001.147.00

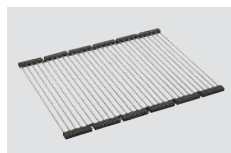

**Inox Pad**  
CHF 125.– 40.001.138.00

Green Line ist eine eigenständige auf Nachhaltigkeit ausgerichtete Produktausführung.  
Green Line è una versione di prodotto autonoma calibrata sulla sostenibilità.

Varianten: Der Austausch von Zugknöpfen erfolgt mittels Variantencode. Mehr Infos siehe Seite 395.  
Varianti: La sostituzione di pomoli avviene mediante codice variante. Per maggiori informazioni, vedere pag. 395.

Preis CHF/Prezzo in CHF

Modell Modello	Material Materiale	Ventil sFlow, Typ S Piletta sFlow, Typ S	Artikel-Nr. N. di articolo	Beckentiefe Profondità	Exkl. MWST IVA esclusa	Inkl. MWST IVA inclusa	VRG TRA		
<b>Vantis VG 50-42U Green</b>	Edelstahl, matt Acciaio inox, opaco	18 / 10	3 1/2" TouchFlow	10.105.765.00	160 mm	A	1196.–	1293.–	0.19
			3 1/2" Raumspar Salvaspazio	10.105.766.00	160 mm	A	998.–	1079.–	
			3 1/2" Tipo	10.105.767.00	160 mm	A	949.–	1026.–	

# Vantis: VG 50-35U Green

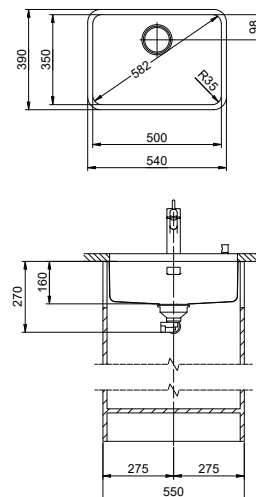

Schwenkbare Überlaufkappe  
Placchetta di troppieno a ribalta

Obenliegendes Sieb  
Griglietta superiore



Zeichnung als pdf / dxf und Montageanleitung siehe:  
V. disegno in formato pdf / dxf e montaggio:  
suter.ch

## Optionales Zubehör/Accessori opzionali



**Resteschale** gelocht  
**Vaschetta** forato  
CHF 106.- 40.000.916.00

Green Line ist eine eigenständige auf Nachhaltigkeit ausgerichtete Produktausführung.  
Green Line è una versione di prodotto autonoma calibrata sulla sostenibilità.

Varianten: Der Austausch von Zugknöpfen erfolgt mittels Variantencode. Mehr Infos siehe Seite 395.  
Varianti: La sostituzione di pomoli avviene mediante codice variante. Per maggiori informazioni, vedere pag. 395.

Preis CHF/Prezzo in CHF

Modell Modello	Material Materiale	Ventil sFlow, Typ S Piletta sFlow, Typ S	Artikel-Nr. N. di articolo	Beckentiefe Profondità	Exkl. MWST IVA esclusa	Inkl. MWST IVA inclusa	VRG TRA		
Vantis VG 50-35U Green	Edelstahl, matt Acciaio inox, opaco	18 / 10	3 1/2" TouchFlow	10.105.768.00	160 mm	A	975.-	1054.-	0.19
			3 1/2" Raumspar Salvaspazio	10.105.769.00	160 mm	A	777.-	840.-	
			3 1/2" Tipo	10.105.770.00	160 mm	A	728.-	787.-	

# Vantis: VG 55U Green

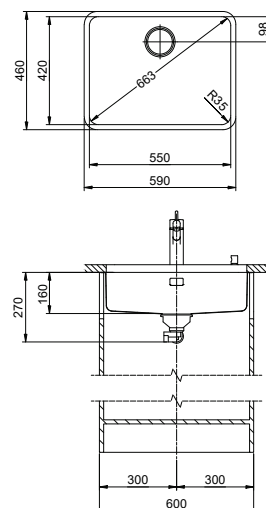

Schwenkbare Überlaufkappe  
Placchetta di troppieno a ribalta

Obenliegendes Sieb  
Griglietta superiore

14



Zeichnung als pdf / dxf und Montageanleitung siehe:  
V. disegno in formato pdf / dxf e montaggio:  
suter.ch

## Optionales Zubehör/Accessori opzionali

312

<b>Resteschale</b> gelocht <b>Vaschetta</b> forato	<b>Resteschale</b> ungelocht <b>Vaschetta</b> non forato	<b>Schneidebrett</b> aus Glas <b>Tagliere</b> in vetro	<b>Holz-Schneidebrett</b> aus Nussbaum <b>Tagliere</b> in legno di noce
CHF 106.– 40.000.914.00	CHF 106.– 40.001.290.00	CHF 151.– 40.000.915.00	CHF 151.– 40.001.147.00

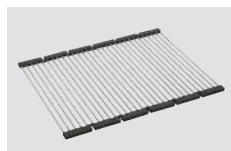

**Inox Pad**  
CHF 125.– 40.001.138.00

Green Line ist eine eigenständige auf Nachhaltigkeit ausgerichtete Produktausführung.  
Green Line è una versione di prodotto autonoma calibrata sulla sostenibilità.

Varianten: Der Austausch von Zugknöpfen erfolgt mittels Variantencode. Mehr Infos siehe Seite 395.  
Varianti: La sostituzione di pomoli avviene mediante codice variante. Per maggiori informazioni, vedere pag. 395.

### Preis CHF/Prezzo in CHF

Modell Modello	Material Materiale	Ventil sFlow, Typ S Piletta sFlow, Typ S	Artikel-Nr. N. di articolo	Beckentiefe Profondità	Exkl. MWST IVA esclusa	Inkl. MWST IVA inclusa	VRG TRA		
<b>Vantis VG 55U Green</b>	Edelstahl, matt Acciaio inox, opaco	18 / 10	3 1/2" TouchFlow	10.105.774.00	160 mm	A	1428.–	1544.–	0.19
			3 1/2" Raumspar Salvaspazio	10.105.775.00	160 mm	A	1230.–	1330.–	
			3 1/2" Tipo	10.105.776.00	160 mm	A	1181.–	1277.–	

## Vantis: VX 34U Varix

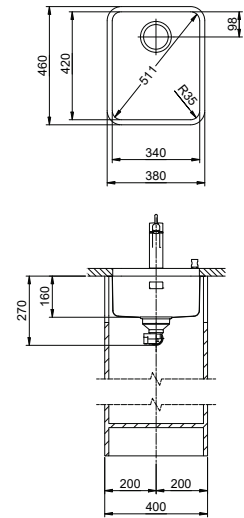

 Verdeckter Überlauf  
Trooppieno coperto

 15



Zeichnung als pdf / dxf und Montageanleitung siehe:  
V. disegno in formato pdf / dxf e montaggio:  
suter.ch

## Optionales Zubehör/Accessori opzionali

 312



**Resteschale** gelocht  
**Vaschetta** forato

CHF 106.– 40.000.914.00



**Resteschale** ungelocht  
**Vaschetta** non forato

CHF 106.– 40.001.290.00



**Schneidebrett** aus Glas  
**Tagliere** in vetro

CHF 151.– 40.000.915.00



**Holz-Schneidebrett** aus Nussbaum  
**Tagliere** in legno di noce

CHF 151.– 40.001.147.00

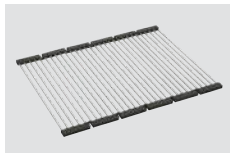

**Inox Pad**

CHF 125.– 40.001.138.00



Varianten: Der Austausch von Zugknöpfen erfolgt mittels Variantencode. Mehr Infos siehe Seite 395.  
Varianti: La sostituzione di pomoli avviene mediante codice variante. Per maggiori informazioni, vedere pag. 395.

Preis CHF/Prezzo in CHF

Modell Modello	Material Materiale	Ventil Piletta	Artikel-Nr. N. di articolo	Beckentiefe Profondità	Exkl. MWST IVA esclusa	Inkl. MWST IVA inclusa
Vantis VX 34U Varix	Edelstahl, mid-matt Acciaio inox, mid-matt	18/10 3 ½" Raumspär Salvaspazio	10.105.250.00 	160 mm	A	662.– 716.–
		3 ½" Siebstopfen A tappo con griglietta	10.105.251.00 	160 mm	A	613.– 663.–

# Vantis: VX 40U Varix

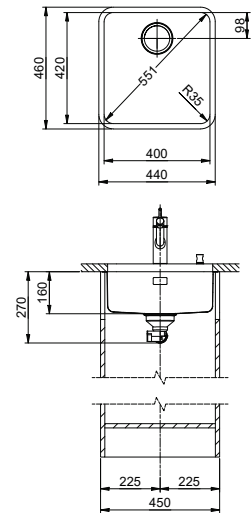

Verdeckter Überlauf  
Troppieno coperto

15



Zeichnung als pdf / dxf und Montageanleitung siehe:  
V. disegno in formato pdf / dxf e montaggio:  
suter.ch

## Optionales Zubehör / Accessori opzionali

312



**Resteschale gelocht**  
**Vaschetta forato**  
CHF 106.- 40.000.914.00



**Resteschale ungelocht**  
**Vaschetta non forato**  
CHF 106.- 40.001.290.00



**Schneidebrett aus Glas**  
**Tagliere in vetro**  
CHF 151.- 40.000.915.00



**Holz-Schneidebrett aus Nussbaum**  
**Tagliere in legno di noce**  
CHF 151.- 40.001.147.00

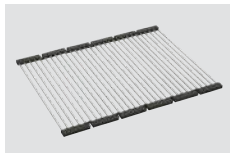

**Inox Pad**  
CHF 125.- 40.001.138.00





Varianten: Der Austausch von Zugknöpfen erfolgt mittels Variantencode. Mehr Infos siehe Seite 395.  
Varianti: La sostituzione di pomoli avviene mediante codice variante. Per maggiori informazioni, vedere pag. 395.

### Preis CHF / Prezzo in CHF

Modell Modello	Material Materiale	Ventil Piletta	Artikel-Nr. N. di articolo	Beckentiefe Profondità	Exkl. MWST IVA esclusa	Inkl. MWST IVA inclusa
Vantis VX 40U Varix	Edelstahl, mid-matt Acciaio inox, mid-matt	18/10 3 1/2" Raumspär Salvaspazio	10.103.958.00	160 mm	A 682.-	737.-
		3 1/2" Siebstopfen A tappo con griglietta	10.103.959.00	160 mm	A 633.-	684.-

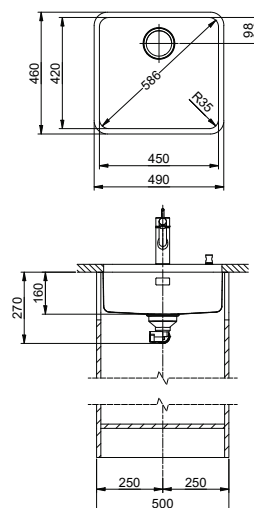
## Vantis: VX 45U Varix



 Verdeckter Überlauf  
Trotopieno coperto

 15



Zeichnung als pdf / dxf und Montageanleitung siehe:  
V. disegno in formato pdf / dxf e montaggio:  
suter.ch

## Optionales Zubehör/Accessori opzionali

 312



**Resteschale** gelocht  
**Vaschetta** forato

CHF 106.– 40.000.914.00



**Resteschale** ungelocht  
**Vaschetta** non forato

CHF 106.– 40.001.290.00



**Schneidebrett** aus Glas  
**Tagliere** in vetro

CHF 151.– 40.000.915.00



**Holz-Schneidebrett** aus Nussbaum  
**Tagliere** in legno di noce

CHF 151.– 40.001.147.00

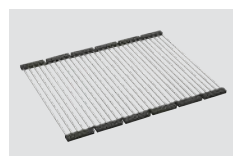

**Inox Pad**

CHF 125.– 40.001.138.00

 Varianten: Der Austausch von Zugknöpfen erfolgt mittels Variantencode. Mehr Infos siehe Seite 395.  
Varianti: La sostituzione di pomoli avviene mediante codice variante. Per maggiori informazioni, vedere pag. 395.

Preis CHF/Prezzo in CHF

Modell Modello	Material Materiale	Ventil Piletta	Artikel-Nr. N. di articolo	Beckentiefe Profondità	Exkl. MWST IVA esclusa	Inkl. MWST IVA inclusa
Vantis VX 45U Varix	Edelstahl, mid-matt Acciaio inox, mid-matt	18/10 3 ½" Raumspär Salvaspazio	10.104.143.00 	160 mm	A	699.– 756.–
		3 ½" Siebstopfen A tappo con griglietta	10.104.144.00 	160 mm	A	650.– 703.–

# Vantis: VX 50-42U Varix

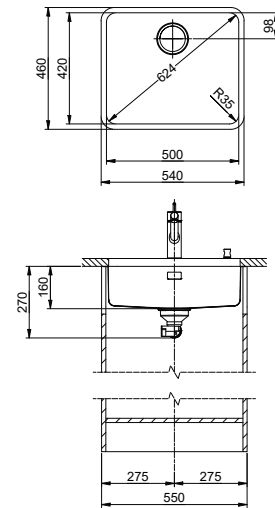

Verdeckter Überlauf  
Troppipieno coperto

15



Zeichnung als pdf / dxf und Montageanleitung siehe:  
V. disegno in formato pdf / dxf e montaggio:  
suter.ch

## Optionales Zubehör / Accessori opzionali

312



**Resteschale gelocht**  
**Vaschetta forata**  
CHF 106.- 40.000.914.00



**Resteschale ungelocht**  
**Vaschetta non forata**  
CHF 106.- 40.001.290.00



**Schneidebrett aus Glas**  
**Tagliere in vetro**  
CHF 151.- 40.000.915.00



**Holz-Schneidebrett aus Nussbaum**  
**Tagliere in legno di noce**  
CHF 151.- 40.001.147.00

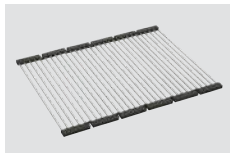

**Inox Pad**  
CHF 125.- 40.001.138.00



Varianten: Der Austausch von Zugknöpfen erfolgt mittels Variantencode. Mehr Infos siehe Seite 395.  
Varianti: La sostituzione di pomoli avviene mediante codice variante. Per maggiori informazioni, vedere pag. 395.

**Preis CHF / Prezzo in CHF**

Modell Modello	Material Materiale	Ventil Piletta	Artikel-Nr. N. di articolo	Beckentiefe Profondità	Exkl. MWST IVA esclusa	Inkl. MWST IVA inclusa
Vantis VX 50-42U Varix	Edelstahl, mid-matt Acciaio inox, mid-matt	18/10 3 1/2" Raumspär Salvaspazio	10.103.960.00	160 mm	A 723.-	782.-
		3 1/2" Siebstopfen A tappo con griglietta	10.103.961.00	160 mm	A 674.-	729.-

## Vantis: VX 55U Varix

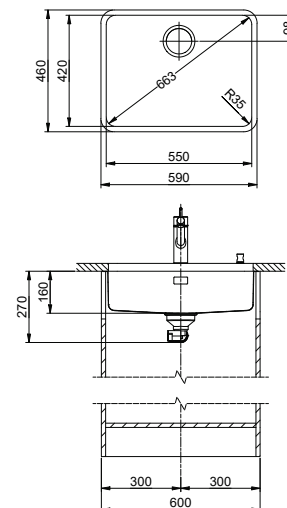

Verdeckter Überlauf  
Troppipieno coperto

15



Zeichnung als pdf / dxf und Montageanleitung siehe:  
V. disegno in formato pdf / dxf e montaggio:  
suter.ch

## Optionales Zubehör/Accessori opzionali

312



**Resteschale** gelocht  
**Vaschetta** forato

CHF 106.– 40.000.914.00



**Resteschale** ungelocht  
**Vaschetta** non forato

CHF 106.– 40.001.290.00



**Schneidebrett** aus Glas  
**Tagliere** in vetro

CHF 151.– 40.000.915.00



**Holz-Schneidebrett** aus Nussbaum  
**Tagliere** in legno di noce

CHF 151.– 40.001.147.00

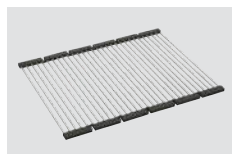

**Inox Pad**

CHF 125.– 40.001.138.00

Varianten: Der Austausch von Zugknöpfen erfolgt mittels Variantencode. Mehr Infos siehe Seite 395.  
Varianti: La sostituzione di pomoli avviene mediante codice variante. Per maggiori informazioni, vedere pag. 395.

Preis CHF/Prezzo in CHF

Modell Modello	Material Materiale	Ventil Piletta	Artikel-Nr. N. di articolo	Beckentiefe Profondità	Exkl. MWST IVA esclusa	Inkl. MWST IVA inclusa
Vantis VX 55U Varix	Edelstahl, mid-matt Acciaio inox, mid-matt	18/10 3 ½" Raumspär Salvaspazio	10.104.145.00	160 mm	A	743.– 803.–
		3 ½" Siebstopfen A tappo con griglietta	10.104.146.00	160 mm	A	694.– 750.–

Silver Star: SIL 18U + SIL 34U

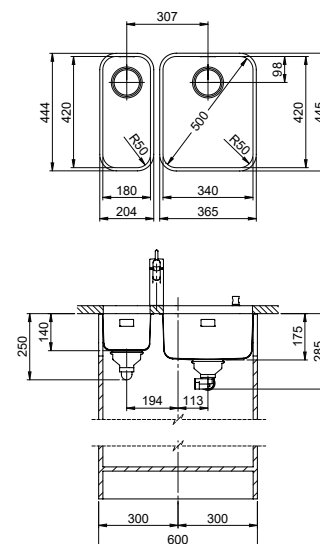

Verdeckter Überlauf  
Troppieno coperto

15

Obenliegendes Sieb  
Griglietta superiore

14



Zeichnung als pdf / dxf und Montageanleitung siehe:  
V. disegno in formato pdf / dxf e montaggio:  
suter.ch

**i Wählen Sie den Oberflächenfinish:**  
In den Ausführungen glanz und matt erhältlich.  
**Scegliete la finitura:**  
Disponibile nelle finiture lucido e opaco.

**i** Beim Set SIL 18U + SIL 34U ist die Resteschale aus Edelstahl, gelocht, 40.000.914.00, im Preis begriffen. Il prezzo del set SIL 18U + SIL 34U è comprensivo della vaschetta in acciaio inox, 40.000.914.00, forato.

**!** Varianten: Der Austausch von Zugknöpfen erfolgt mittels Variantencode. Mehr Infos siehe Seite 395.  
Varianti: La sostituzione di pomoli avviene mediante codice variante. Per maggiori informazioni, vedere pag. 395.

Preis CHF/Prezzo in CHF

Modell Modello	Material Materiale	Ventil Piletta	Artikel-Nr. N. di articolo	Beckentiefe Profondità	Exkl. MWST IVA esclusa	Inkl. MWST IVA inclusa
<b>Silver Star SIL 18U</b>	Edelstahl, matt Acciaio inox, opaco	18/10 3 1/2" Tipo	10.102.117.00	140 mm	A 571.-	617.-
	Edelstahl, glanz Acciaio inox, lucido	18/10 3 1/2" Tipo	10.103.610.00	140 mm	A 571.-	617.-
<b>Silver Star SIL 34U</b>	Edelstahl, matt Acciaio inox, opaco	18/10 3 1/2" Raumspar Salvaspazio	10.102.118.00	175 mm	A 741.-	801.-
		18/10 3 1/2" Tipo	10.103.085.00	175 mm	A 700.-	757.-
	Edelstahl, glanz Acciaio inox, lucido	18/10 3 1/2" Raumspar Salvaspazio	10.103.612.00	175 mm	A 741.-	801.-
		18/10 3 1/2" Tipo	10.103.613.00	175 mm	A 700.-	757.-
<b>Silver Star SIL 18U + Silver Star SIL 34U</b>	Edelstahl, matt Acciaio inox, opaco	18/10 3 1/2" Tipo + Raumspar Tipo + Salvaspazio	10.102.567.00	140 mm 175 mm	A 1273.-	1376.-
		18/10 3 1/2" Tipo + Tipo	10.103.086.00	140 mm 175 mm	A 1232.-	1332.-
<b>inklusive Resteschale Vaschetta inclusa</b>	Edelstahl, glanz Acciaio inox, lucido	18/10 3 1/2" Tipo + Raumspar Tipo + Salvaspazio	10.103.615.00	140 mm 175 mm	A 1273.-	1376.-
		18/10 3 1/2" Tipo + Tipo	10.103.616.00	140 mm 175 mm	A 1232.-	1332.-

## Silver Star: SIL 18/34U

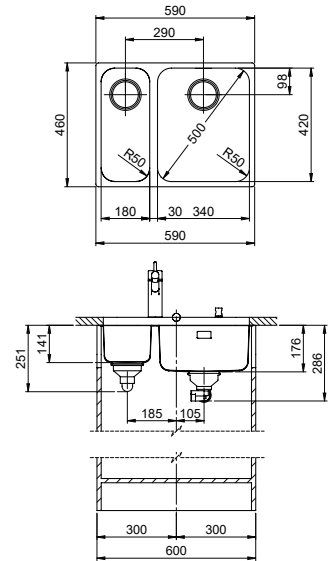

Verdeckter Überlauf  
Trooppieno coperto

15

Obenliegendes Sieb  
Griglietta superiore

14



Zeichnung als pdf / dxf und Montageanleitung siehe:  
V. disegno in formato pdf / dxf e montaggio:  
suter.ch

**Wählen Sie den Oberflächenfinish:**

In den Ausführungen glanz und matt erhältlich.

**Scegliete la finitura:**

Disponibile nelle finiture lucido e opaco.



Varianten: Der Austausch von Zugknöpfen erfolgt mittels Variantencode. Mehr Infos siehe Seite 395.

Varianti: La sostituzione di pomoli avviene mediante codice variante. Per maggiori informazioni, vedere pag.395.

**Preis CHF/Prezzo in CHF**

Modell Modello	Material Materiale	Ventil Piletta	Artikel-Nr. N. di articolo	Restebecken Vasca per raccolta residui	Exkl. MWST IVA esclusa	Inkl. MWST IVA inclusa	
<b>Silver Star SIL 18/34U</b>	Edelstahl, matt Acciaio inox, opaco	18/10	3 1/2" Tipo + Raumspar Tipo + Salvaspazio	Links / Sinistra	A	1318.–	1425.–
			3 1/2" Tipo + Tipo		A	1277.–	1380.–
	Edelstahl, glanz Acciaio inox, lucido	18/10	3 1/2" Tipo + Raumspar Tipo + Salvaspazio	Links / Sinistra	A	1318.–	1425.–
			3 1/2" Tipo + Tipo		A	1277.–	1380.–
<b>Silver Star SIL 34/18U</b>	Edelstahl, matt Acciaio inox, opaco	18/10	3 1/2" Raumspar + Tipo Salvaspazio + Tipo	Rechts / Destra	A	1318.–	1425.–
			3 1/2" Tipo + Tipo		A	1277.–	1380.–
	Edelstahl, glanz Acciaio inox, lucido	18/10	3 1/2" Raumspar + Tipo Salvaspazio + Tipo	Rechts / Destra	A	1318.–	1425.–
			3 1/2" Tipo + Tipo		A	1277.–	1380.–

# Silver Star: SIL 45U

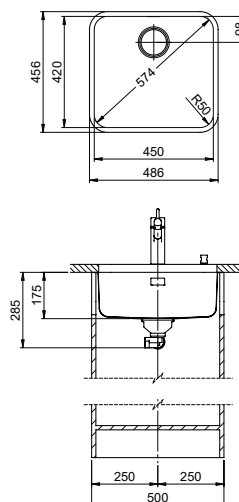

Verdeckter Überlauf  
Troppopieno coperto

Obenliegendes Sieb  
Griglietta superiore

14



Zeichnung als pdf / dxf und Montageanleitung siehe:  
V. disegno in formato pdf / dxf e montaggio:  
suter.ch

## Optionales Zubehör/Accessori opzionali

312



**Resteschale gelocht**  
**Vaschetta forata**  
CHF 106.– 40.000.914.00



**Resteschale ungelocht**  
**Vaschetta non forata**  
CHF 106.– 40.001.290.00



**Schneidebrett aus Glas**  
**Tagliere in vetro**  
CHF 151.– 40.000.915.00



**Holz-Schneidebrett aus Nussbaum**  
**Tagliere in legno di noce**  
CHF 151.– 40.001.147.00

**Wählen Sie den Oberflächenfinish:**  
In den Ausführungen glanz und matt erhältlich.  
**Scegliete la finitura:**  
Disponibile nelle finiture lucido e opaco.

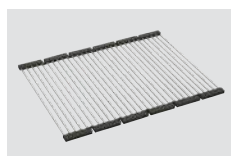

**Inox Pad**  
CHF 125.– 40.001.138.00

Varianten: Der Austausch von Zugknöpfen erfolgt mittels Variantencode. Mehr Infos siehe Seite 395.  
Varianti: La sostituzione di pomoli avviene mediante codice variante. Per maggiori informazioni, vedere pag. 395.

## Preis CHF/Prezzo in CHF

Modell Modello	Material Materiale	Ventil Piletta	Artikel-Nr. N. di articolo	Beckentiefe Profondità	Exkl. MWST IVA esclusa	Inkl. MWST IVA inclusa
<b>Silver Star SIL 45U</b>	Edelstahl, matt Acciaio inox, opaco	18/10 3 1/2" Raumsparsalvaspazio	10.102.669.00	175 mm	A 762.–	824.–
		18/10 3 1/2" Tipo	10.102.979.00	175 mm	A 721.–	779.–
	Edelstahl, glanz Acciaio inox, lucido	18/10 3 1/2" Raumsparsalvaspazio	10.102.811.00	175 mm	A 762.–	824.–
		18/10 3 1/2" Tipo	10.102.980.00	175 mm	A 721.–	779.–
		18/10 3 1/2" Raumsparsalvaspazio	10.103.087.00	120 mm*	A 1198.–	1295.–

\* Modell ist mit Überlaufschlitzen und Ablauf Typ C ausgestattet. /Modello dotato di fessure troppopieno e scarico tipo C.

# Silver Star: SIS 50U

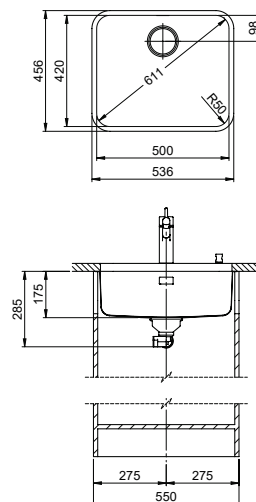

Verdeckter Überlauf  
Trooppieno coperto

Obenliegendes Sieb  
Griglietta superiore



Zeichnung als pdf / dxf und Montageanleitung siehe:  
V. disegno in formato pdf / dxf e montaggio:  
suter.ch

## Optionales Zubehör/Accessori opzionali



**Resteschale** gelocht  
**Vaschetta** forato  
CHF 106.– 40.000.914.00

**Resteschale** ungelocht  
**Vaschetta** non forato  
CHF 106.– 40.001.290.00

**Schneidebrett** aus Glas  
**Tagliere** in vetro  
CHF 151.– 40.000.915.00

**Holz-Schneidebrett** aus Nussbaum  
**Tagliere** in legno di noce  
CHF 151.– 40.001.147.00

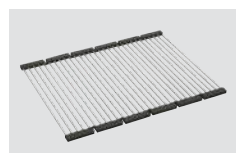

**Inox Pad**  
CHF 125.– 40.001.138.00

**Wählen Sie den Oberflächenfinish:**  
In den Ausführungen glanz und matt erhältlich.  
**Scelgiete la finitura:**  
Disponibile nelle finiture lucido e opaco.

Varianten: Der Austausch von Zugknöpfen erfolgt mittels Variantencode. Mehr Infos siehe Seite 395.  
Varianti: La sostituzione di pomoli avviene mediante codice variante. Per maggiori informazioni, vedere pag. 395.

### Preis CHF/Prezzo in CHF

Modell Modello	Material Materiale	Ventil Piletta	Artikel-Nr. N. di articolo	Beckentiefe Profondità	Exkl. MWST IVA esclusa	Inkl. MWST IVA inclusa
<b>Silver Star SIS 50U</b>	Edelstahl, matt Acciaio inox, opaco	18/10 3 1/2" Raumsparspar Salvaspazio	10.102.670.00	175 mm	A 954.–	1031.–
		3 1/2" Tipo	10.102.981.00	175 mm	A 913.–	987.–
	Edelstahl, glanz Acciaio inox, lucido	18/10 3 1/2" Raumsparspar Salvaspazio	10.102.812.00	175 mm	A 954.–	1031.–
		3 1/2" Tipo	10.102.982.00	175 mm	A 913.–	987.–

# Silver Star: SIL 50U + SIL 9U

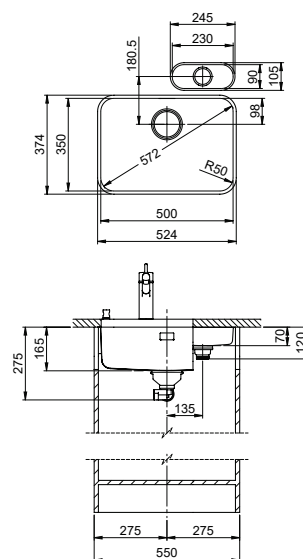

Verdeckter Überlauf  
Trooppieno coperto

Obenliegendes Sieb  
Griglietta superiore

14



Zeichnung als pdf / dxf und Montageanleitung siehe:  
V. disegno in formato pdf / dxf e montaggio:  
suter.ch

## Optionales Zubehör/Accessori opzionali

312



**Resteschale zu SIL 9U**  
**Vaschetta per SIL 9U**

CHF 81.– 40.000.042.00

**Resteschale gelocht**  
**Vaschetta forato**

CHF 106.– 40.000.916.00

**Wählen Sie den Oberflächenfinish:**  
In den Ausführungen glanz und matt erhältlich.  
**Scelgiete la finitura:**  
Disponibile nelle finiture lucido e opaco.

**!** Varianten: Der Austausch von Zugknöpfen erfolgt mittels Variantencode. Mehr Infos siehe Seite 395.  
 Varianti: La sostituzione di pomoli avviene mediante codice variante. Per maggiori informazioni, vedere pag.395.

Preis CHF/Prezzo in CHF

Modell Modello	Material Materiale	Ventil Piletta	Artikel-Nr. N. di articolo	Beckentiefe Profondità	Exkl. MWST IVA esclusa	Inkl. MWST IVA inclusa	
<b>Silver Star SIL 50U</b>	Edelstahl, matt Acciaio inox, opaco	18/10 3 1/2" Raumspar Salvaspazio	10.102.561.00 <b>L</b>	165 mm	A	742.–	802.–
		3 1/2" Tipo	10.102.564.00 <b>L</b>	165 mm	A	701.–	758.–
	Edelstahl, glanz Acciaio inox, lucido	18/10 3 1/2" Raumspar Salvaspazio	10.102.813.00 <b>L</b>	165 mm	A	742.–	802.–
		3 1/2" Tipo	10.102.814.00 <b>L</b>	165 mm	A	701.–	758.–
<b>Silver Star SIL 9U</b>	Edelstahl, matt Acciaio inox, opaco	18/10 1 1/2" Stopfen A tappo	10.102.671.00 <b>L</b>	70 mm	A	330.–	357.–
	Edelstahl, glanz Acciaio inox, lucido	18/10 1 1/2" Stopfen A tappo	10.102.836.00 <b>L</b>	70 mm	A	330.–	357.–
<b>Silver Star SIL 50U + Silver Star SIL 9U</b>	Edelstahl, matt Acciaio inox, opaco	18/10 3 1/2" Raumspar + Salvaspazio	10.102.672.00 <b>L</b>	165 mm 70 mm	A	1040.–	1124.–
		1 1/2" Stopfen A tappo					
		3 1/2" Tipo +	10.103.131.00 <b>L</b>	165 mm 70 mm	A	999.–	1080.–
	1 1/2" Stopfen A tappo						
	Edelstahl, glanz Acciaio inox, lucido	18/10 3 1/2" Raumspar + Salvaspazio	10.102.815.00 <b>L</b>	165 mm 70 mm	A	1040.–	1124.–
		1 1/2" Stopfen A tappo					
3 1/2" Tipo +		10.103.130.00 <b>L</b>	165 mm 70 mm	A	999.–	1080.–	
1 1/2" Stopfen A tappo							



Silver Star: SIL 50U + SIL 9U



Silver Star: SIL 50U

# Silver Star: SIL 55U

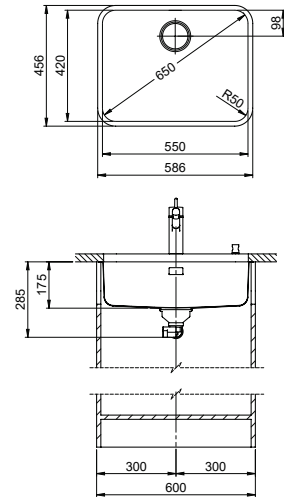

Verdeckter Überlauf  
Trooppieno coperto

15

Obenliegendes Sieb  
Griglietta superiore

14



Zeichnung als pdf / dxf und Montageanleitung siehe:  
V. disegno in formato pdf / dxf e montaggio:  
suter.ch

## Optionales Zubehör/Accessori opzionali

312



**Resteschale gelocht**  
**Vaschetta forata**  
CHF 106.– 40.000.914.00



**Resteschale ungelocht**  
**Vaschetta non forata**  
CHF 106.– 40.001.290.00



**Schneidebrett aus Glas**  
**Tagliere in vetro**  
CHF 151.– 40.000.915.00



**Holz-Schneidebrett aus Nussbaum**  
**Tagliere in legno di noce**  
CHF 151.– 40.001.147.00

**Wählen Sie den Oberflächenfinish:**  
In den Ausführungen glanz und matt erhältlich.  
**Scelgiete la finitura:**  
Disponibile nelle finiture lucido e opaco.

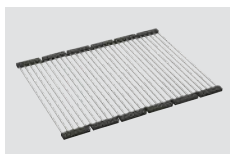

**Inox Pad**  
CHF 125.– 40.001.138.00

Varianten: Der Austausch von Zugknöpfen erfolgt mittels Variantencode. Mehr Infos siehe Seite 395.  
Varianti: La sostituzione di pomoli avviene mediante codice variante. Per maggiori informazioni, vedere pag.395.

## Preis CHF/Prezzo in CHF

Modell Modello	Material Materiale	Ventil Piletta	Artikel-Nr. N. di articolo	Beckentiefe Profondità	Exkl. MWST IVA esclusa	Inkl. MWST IVA inclusa
<b>Silver Star SIL 55U</b>	Edelstahl, matt Acciaio inox, opaco	18/10 3 1/2" Raumsparsalvaspazio	10.103.288.00	175 mm	A 1084.–	1172.–
		3 1/2" Tipo	10.103.289.00	175 mm	A 1043.–	1127.–
	Edelstahl, glanz Acciaio inox, lucido	18/10 3 1/2" Raumsparsalvaspazio	10.103.286.00	175 mm	A 1084.–	1172.–
		3 1/2" Tipo	10.103.287.00	175 mm	A 1043.–	1127.–

## Silver Star: SX 40U Varix

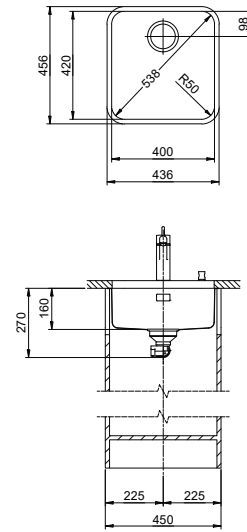

Verdeckter Überlauf, ohne Magnethalterung  
Troppieno coperto, senza supporto magnetico



Zeichnung als pdf / dxf und Montageanleitung siehe:  
V. disegno in formato pdf / dxf e montaggio:  
suter.ch

## Optionales Zubehör/Accessori opzionali



**Resteschale** gelocht  
**Vaschetta** forato

CHF 106.– 40.000.914.00



**Resteschale** ungelocht  
**Vaschetta** non forato

CHF 106.– 40.001.290.00



**Schneidebrett** aus Glas  
**Tagliere** in vetro

CHF 151.– 40.000.915.00



**Holz-Schneidebrett** aus Nussbaum  
**Tagliere** in legno di noce

CHF 151.– 40.001.147.00

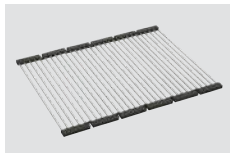

**Inox Pad**

CHF 125.– 40.001.138.00

Varianten: Der Austausch von Zugknöpfen erfolgt mittels Variantencode. Mehr Infos siehe Seite 395.  
Varianti: La sostituzione di pomoli avviene mediante codice variante. Per maggiori informazioni, vedere pag. 395.

Preis CHF/Prezzo in CHF

Modell Modello	Material Materiale	Ventil Piletta	Artikel-Nr. N. di articolo	Beckentiefe Profondità	Exkl. MWST IVA esclusa	Inkl. MWST IVA inclusa
<b>Silver Star</b> <b>SX 40U Varix</b>	Edelstahl, mid-matt Eco Acciaio inox, mid-matt Eco	3 1/2" Raumspär Salvaspazio	10.105.318.00	160 mm	A 569.–	615.–
		3 1/2" Siebstopfen A tappo c. griglietta	10.105.319.00	160 mm	A 528.–	571.–

# Silver Star: SX 50-42U Varix

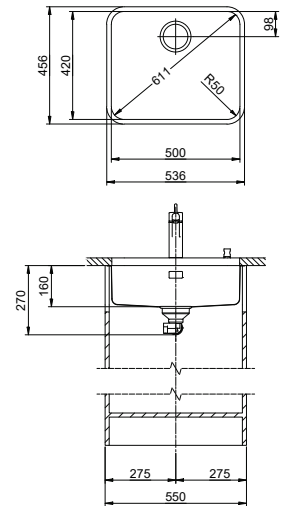

Verdeckter Überlauf, ohne Magnethalterung  
Troppieno coperto, senza supporto magnetico



Zeichnung als pdf / dxf und Montageanleitung siehe:  
V. disegno in formato pdf / dxf e montaggio:  
suter.ch

## Optionales Zubehör / Accessori opzionali



**Resteschale gelocht**  
**Vaschetta forato**  
CHF 106.– 40.000.914.00



**Resteschale ungelocht**  
**Vaschetta non forato**  
CHF 106.– 40.001.290.00



**Schneidebrett aus Glas**  
**Tagliere in vetro**  
CHF 151.– 40.000.915.00



**Holz-Schneidebrett aus Nussbaum**  
**Tagliere in legno di noce**  
CHF 151.– 40.001.147.00

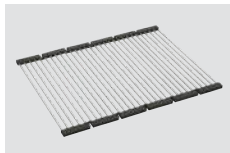

**Inox Pad**  
CHF 125.– 40.001.138.00

Varianten: Der Austausch von Zugknöpfen erfolgt mittels Variantencode. Mehr Infos siehe Seite 395.  
Varianti: La sostituzione di pomoli avviene mediante codice variante. Per maggiori informazioni, vedere pag. 395.

Preis CHF / Prezzo in CHF

Modell Modello	Material Materiale	Ventil Piletta	Artikel-Nr. N. di articolo	Beckentiefe Profondità	Exkl. MWST IVA esclusa	Inkl. MWST IVA inclusa
<b>Silver Star</b> <b>SX 50-42U Varix</b>	Edelstahl, mid-matt Eco Acciaio inox, mid-matt Eco	3 1/2" Raumspär Salvaspazio	10.105.316.00	160 mm	A 657.–	710.–
		3 1/2" Siebstopfen A tappo c. griglietta	10.105.317.00	160 mm	A 616.–	666.–

Comfort: COM 34U

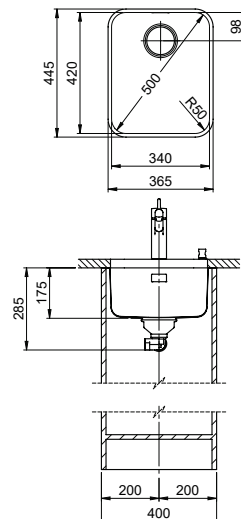

Verdeckter Überlauf  
Trotopieno coperto

Obenliegendes Sieb  
Griglietta superiore



Zeichnung als pdf / dxf und Montageanleitung siehe:  
V. disegno in formato pdf / dxf e montaggio:  
suter.ch

Optionales Zubehör / Accessori opzionali



<b>Resteschale</b> gelocht <b>Vaschetta</b> forato	<b>Schneidebrett</b> aus Glas <b>Tagliere</b> in vetro	<b>Inox Pad</b>
CHF 106.– 40.000.971.00	CHF 151.– 40.000.915.00	CHF 125.– 40.001.138.00

Varianten: Der Austausch von Zugknöpfen erfolgt mittels Variantencode. Mehr Infos siehe Seite 395.  
Varianti: La sostituzione di pomoli avviene mediante codice variante. Per maggiori informazioni, vedere pag. 395.

Preis CHF / Prezzo in CHF

Modell Modello	Material Materiale	Ventil Piletta	Artikel-Nr. N. di articolo	Beckentiefe Profondità	Exkl. MWST IVA esclusa	Inkl. MWST IVA inclusa
Comfort COM 34U	Edelstahl, glanz Acciaio inox, lucido	18/10 3 1/2" Raumspar Salvaspazio	10.102.753.00	175 mm	A 741.–	801.–
		3 1/2" Tipo	10.103.098.00	175 mm	A 700.–	757.–
		1 1/2" Standrohr Con tubo	10.102.752.00	175 mm	A 583.–	630.–

Comfort: COM 40U

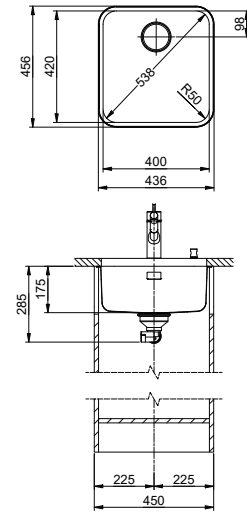

Verdeckter Überlauf  
Trooppieno coperto

15

Obenliegendes Sieb  
Griglietta superiore

14



Zeichnung als pdf / dxf und Montageanleitung siehe:  
V. disegno in formato pdf / dxf e montaggio:  
suter.ch

Optionales Zubehör/Accessori opzionali

312



**Resteschale gelocht**  
**Vaschetta forata**  
CHF 106.– 40.000.914.00



**Resteschale ungelocht**  
**Vaschetta non forata**  
CHF 106.– 40.001.290.00



**Schneidebrett aus Glas**  
**Tagliere in vetro**  
CHF 151.– 40.000.915.00



**Holz-Schneidebrett aus Nussbaum**  
**Tagliere in legno di noce**  
CHF 151.– 40.001.147.00

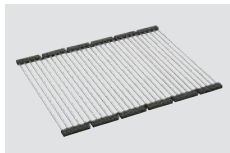

**Inox Pad**  
CHF 125.– 40.001.138.00

Varianten: Der Austausch von Zugknöpfen erfolgt mittels Variantencode. Mehr Infos siehe Seite 395.  
Varianti: La sostituzione di pomoli avviene mediante codice variante. Per maggiori informazioni, vedere pag. 395.

Preis CHF/Prezzo in CHF

Modell Modello	Material Materiale	Ventil Piletta	Artikel-Nr. N. di articolo	Beckentiefe Profondità	Exkl. MWST IVA esclusa	Inkl. MWST IVA inclusa		
Comfort: COM 40U	Edelstahl, glanz Acciaio inox, lucido	18/10	3 1/2" Raumspar Salvaspazio	10.103.272.00	175 mm	A	765.–	827.–
			3 1/2" Tipo	10.103.273.00	175 mm	A	724.–	783.–

Accento: A 65U

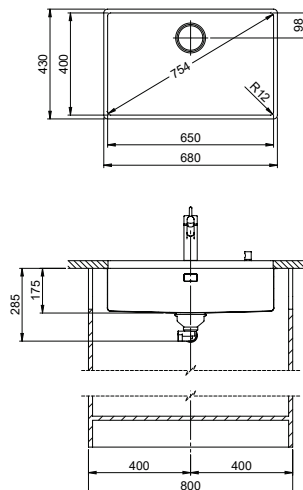
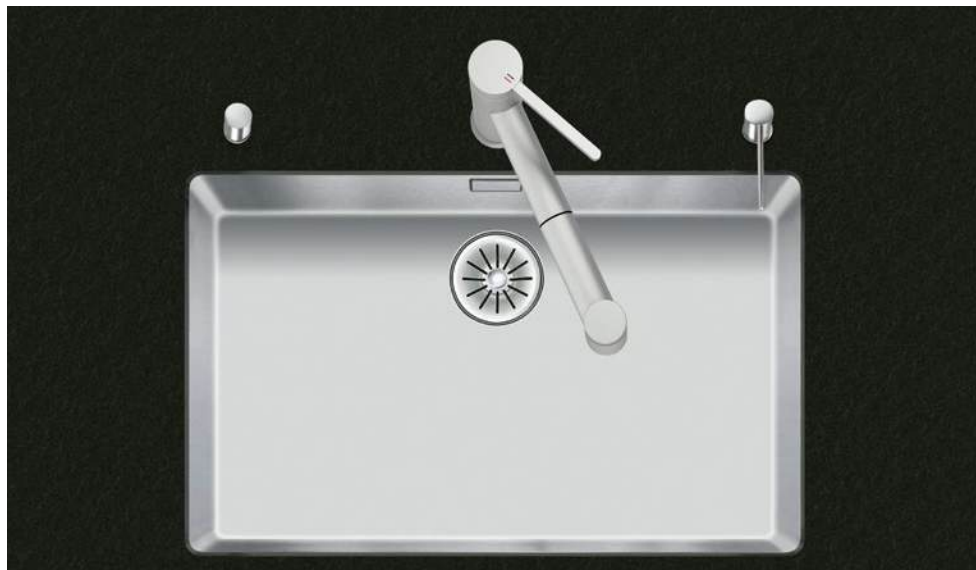

Schwenkbare Überlaufkappe  
Placchetta di troppieno a ribalta



Obenliegendes Sieb  
Griglietta superiore



Zeichnung als pdf / dxf und Montageanleitung siehe:  
V. disegno in formato pdf / dxf e montaggio:  
suter.ch

Optionales Zubehör/Accessori opzionali



Resteschale gelocht  
Vaschetta forata

CHF 106.- 40.000.912.00

Resteschale ungelocht  
Vaschetta non forata

CHF 106.- 40.001.289.00

Schneidebrett aus Glas  
Tagliere in vetro

CHF 151.- 40.000.909.00

Schneidebrett aus Kunststoff  
Tagliere sintetico

CHF 151.- 40.001.277.00

Alle Accento Modelle werden handgefertigt  
Tutti i modelli Accento sono fabbricati a mano

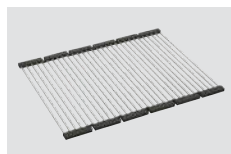

Inox Pad

CHF 125.- 40.001.138.00

Varianten: Der Austausch von Zugknöpfen erfolgt mittels Variantencode. Mehr Infos siehe Seite 395.  
Varianti: La sostituzione di pomoli avviene mediante codice variante. Per maggiori informazioni, vedere pag. 395.

Preis CHF/Prezzo in CHF

Modell Modello	Material Materiale	Ventil Piletta	Artikel-Nr. N. di articolo	Beckentiefe Profondità	Exkl. MWST IVA esclusa	Inkl. MWST IVA inclusa	VRG TRA
Accento A 65U	Edelstahl, glanz Acciaio inox, lucido	18/10 3 1/2" TouchFlow	10.104.568.00	175 mm	2014.-	2177.-	0.19
		3 1/2" Raumspar Salvaspazio	10.104.569.00	175 mm	1816.-	1963.-	
		3 1/2" Tipo	10.104.570.00	175 mm	1775.-	1919.-	

Accento: A 75U

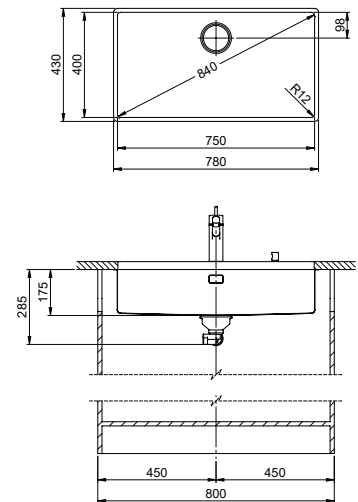
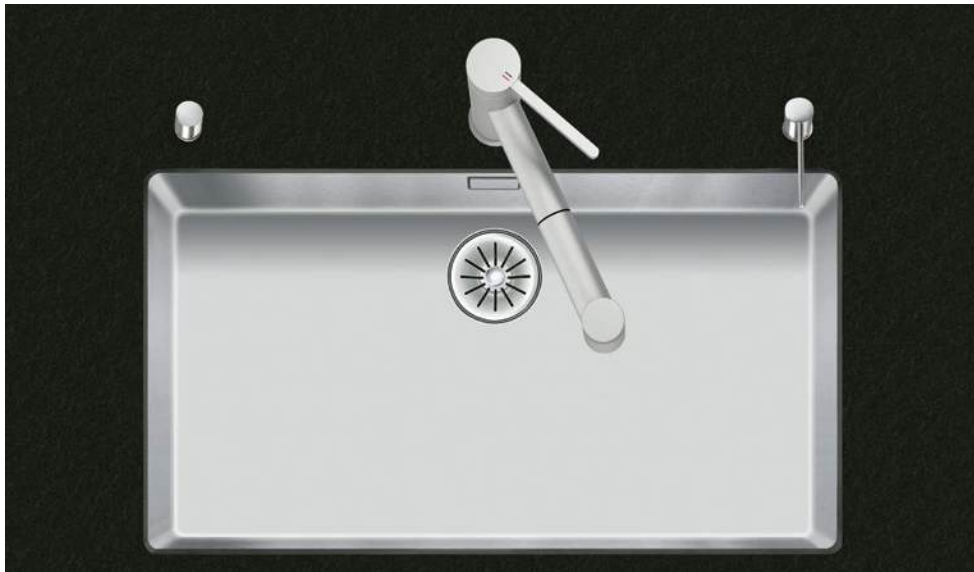

Schwenkbare Überlaufkappe  
Placchetta di troppieno a ribalta

15

Obenliegendes Sieb  
Griglietta superiore

14



Zeichnung als pdf / dxf und Montageanleitung siehe:  
V. disegno in formato pdf / dxf e montaggio:  
suter.ch

Optionales Zubehör/Accessori opzionali

312



**Resteschale gelocht**  
**Vaschetta forato**  
CHF 106.– 40.000.912.00

**Resteschale ungelocht**  
**Vaschetta non forato**  
CHF 106.– 40.001.289.00

**Schneidebrett aus Glas**  
**Tagliere in vetro**  
CHF 151.– 40.000.909.00

**Schneidebrett aus Kunststoff**  
**Tagliere sintetico**  
CHF 151.– 40.001.277.00

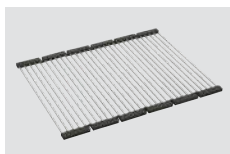

**Innox Pad**  
CHF 125.– 40.001.138.00

Alle Accento Modelle werden handgefertigt  
Tutti i modelli Accento sono fabbricati a mano

Varianten: Der Austausch von Zugknöpfen erfolgt mittels Variantencode. Mehr Infos siehe Seite 395.  
Varianti: La sostituzione di pomoli avviene mediante codice variante. Per maggiori informazioni, vedere pag. 395.

Preis CHF/Prezzo in CHF

Modell Modello	Material Materiale	Ventil Piletta	Artikel-Nr. N. di articolo	Beckentiefe Profondità	Exkl. MWST IVA esclusa	Inkl. MWST IVA inclusa	VRG TRA	
Accento A 75U	Edelstahl, glanz Acciaio inox, lucido	18/10 3 1/2" TouchFlow	10.104.571.00	175 mm	A	2258.–	2441.–	0.19
		3 1/2" Raumspar Salvaspazio	10.104.572.00	175 mm	A	2060.–	2227.–	
		3 1/2" Tipo	10.104.573.00	175 mm	A	2019.–	2183.–	

# Accento: A 40/34U

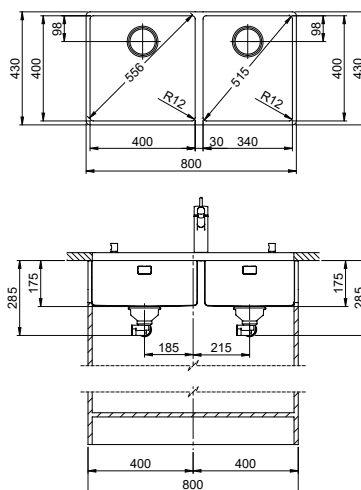

Schwenkbare Überlaufkappe  
Placchetta di troppieno a ribalta

Obenliegendes Sieb  
Griglietta superiore

14



Zeichnung als pdf / dxf und Montageanleitung siehe:  
V. disegno in formato pdf / dxf e montaggio:  
suter.ch

## Optionales Zubehör/Accessori opzionali

312



**Resteschale gelocht**  
**Vaschetta forato**  
CHF 106.– 40.000.912.00

**Resteschale ungelocht**  
**Vaschetta non forato**  
CHF 106.– 40.001.289.00

**Schneidebrett aus Glas**  
**Tagliere in vetro**  
CHF 151.– 40.000.909.00

**Schneidebrett aus Kunststoff**  
**Tagliere sintetico**  
CHF 151.– 40.001.277.00

Alle Accento Modelle werden handgefertigt  
Tutti i modelli Accento sono fabbricati a mano

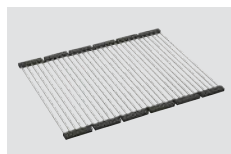

**Inox Pad**  
CHF 125.– 40.001.138.00

Varianten: Der Austausch von Zugknöpfen erfolgt mittels Variantencode. Mehr Infos siehe Seite 395.  
Varianti: La sostituzione di pomoli avviene mediante codice variante. Per maggiori informazioni, vedere pag. 395.

### Preis CHF/Prezzo in CHF

Modell Modello	Material Materiale	Ventil Piletta	Artikel-Nr. N. di articolo	Beckentiefe Profondità	Exkl. MWST IVA esclusa	Inkl. MWST IVA inclusa	VRG TRA
Accento A 40/34U	Edelstahl, glanz Acciaio inox, lucido	18/10 3 1/2" TouchFlow	10.104.574.00	175 mm	A 3319.–	3588.–	0.19
		3 1/2" Raumspar Salvaspazio	10.104.575.00	175 mm	A 2923.–	3160.–	
		3 1/2" Tipo	10.104.576.00	175 mm	A 2841.–	3071.–	

# Gastro MaXX: MGM 1U + MGM 2U

(individuelle Beckengrösse möglich/dimensioni di livello personalizzabili)

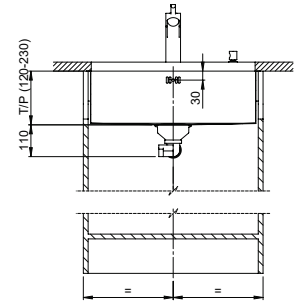
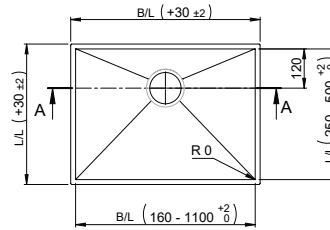

**!** Varianten: Der Austausch von Zugknöpfen erfolgt mittels Variantencode. Mehr Infos siehe Seite 395.  
 Varianti: La sostituzione di pomoli avviene mediante codice variante. Per maggiori informazioni, vedere pag. 395.

Zeichnung als pdf/ dxf und Montageanleitung siehe:  
 V. disegno in formato pdf/ dxf e montaggio: suter.ch

## Optionales Zubehör/Accessori opzionali



Resteschalen, Inox Pad, Schneidebretter nur für Standardmass L/L 350/400/420 mm, Sortiment siehe: Vaschette, Inox Pad, taglieri solo L/L standard 350/400/420 mm, assortimento vedere: suter.ch

## Preis CHF/Prezzo in CHF

Modell Modello	Material Materiale	Ventil Piletta	Artikel-Nr. N. di articolo	Beckendimension in mm Dimensioni di lavello in mm	Exkl. MWST IVA esclusa	Inkl. MWST IVA inclusa			
Gastro MaXX MGM 1U*	Edelstahl, glanz Acciaio inox, lucido	18/10	3 1/2" Raumspar Salvaspazio	B / L 160-550	L / L 250-500	T / P 120-230	D	2390.-	2584.-
			3 1/2" Siebstopfen A tappo c. griglietta					29.001.296.00	2349.-
Gastro MaXX MGM 2U*	Edelstahl, glanz Acciaio inox, lucido	18/10	3 1/2" Raumspar Salvaspazio	>550-1100	250-500	120-230	D	3131.-	3385.-
			3 1/2" Siebstopfen A tappo c. griglietta					29.001.298.00	3090.-

\* Wird nur auf Wunsch hergestellt – 3 Wochen Lieferfrist (kein Lagerartikel)/Producibile solo su richiesta – Termine di consegna di 3 settimane (articolo non a magazzino)  
 Die Gastro Maxx Modelle werden handgefertigt./I modelli Gastro Maxx vengono fabbricati manualmente.

Für Bestellungen zum Gastro Maxx MGM verwenden Sie bitte das elektronische Bestellformular auf suter.ch./Per ordinazioni riguardanti il Gastro Maxx MGM, vi preghiamo di utilizzare il modulo d'ordine elettronico disponibile sul sito suter.ch.

## Rund: R 44BU

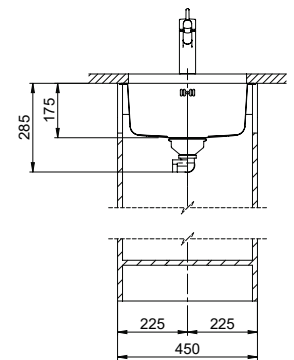
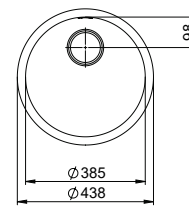

**!** Varianten: Der Austausch von Zugknöpfen erfolgt mittels Variantencode. Mehr Infos siehe Seite 395.  
 Varianti: La sostituzione di pomoli avviene mediante codice variante. Per maggiori informazioni, vedere pag. 395.

Zeichnung als pdf/ dxf und Montageanleitung siehe:  
 V. disegno in formato pdf/ dxf e montaggio: suter.ch

Obenliegendes Sieb  
 Griglietta superiore



## Preis CHF/Prezzo in CHF

Modell Modello	Material Materiale	Ventil Piletta	Artikel-Nr. N. di articolo	Beckentiefe Profondità	Exkl. MWST IVA esclusa	Inkl. MWST IVA inclusa		
Rund R 44BU	Edelstahl, glanz Acciaio inox, lucido	18/10	3 1/2" Raumspar Salvaspazio	10.100.638.00	175 mm	A	896.-	969.-
			3 1/2" Tipo	10.103.132.00	175 mm	A	855.-	924.-

Linero: LIO CD 50U

SCHOCK  
CRISTADUR®

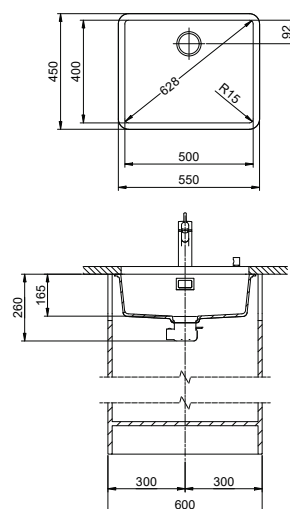
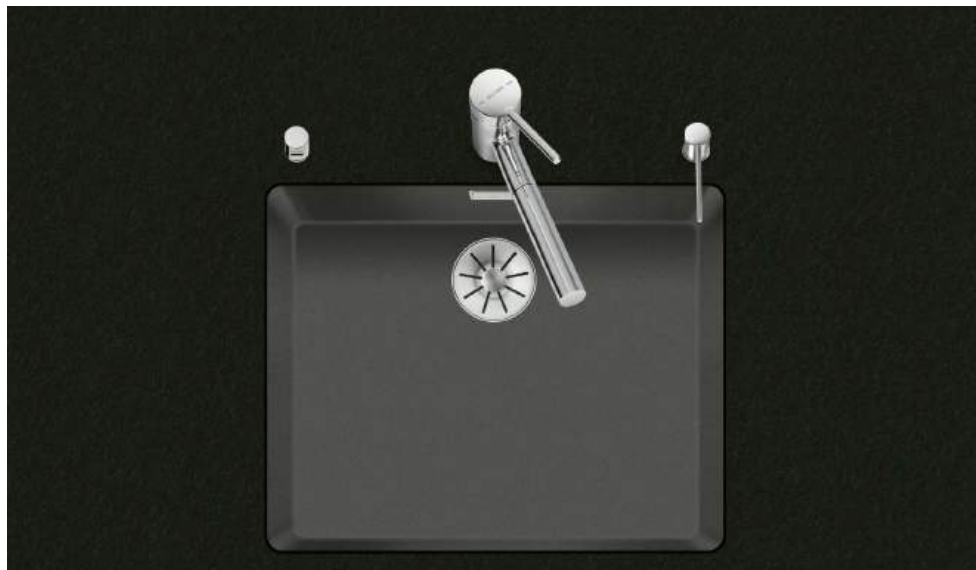

Schwenkbare Überlaufkappe  
Placchetta di troppopieno a ribalta

Obenliegendes Sieb  
Griglietta superiore

14



Zeichnung als pdf / dxf und Montageanleitung siehe:  
V. disegno in formato pdf / dxf e montaggio:  
suter.ch

Optionales Zubehör/Accessori opzionali

312



**Resteschale gelocht**  
**Vaschetta forata**  
CHF 106.- 40.000.912.00

**Resteschale ungelocht**  
**Vaschetta non forata**  
CHF 106.- 40.001.289.00

**Schneidebrett aus Glas**  
**Tagliere in vetro**  
CHF 151.- 40.000.909.00

**Schneidebrett aus Kunststoff**  
**Tagliere sintetico**  
CHF 151.- 40.001.277.00

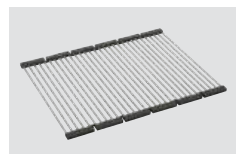

**Inox Pad**  
CHF 125.- 40.001.138.00



**Reinigungsset Easy Care**  
**Kit di pulizia Easy Care**  
CHF 29.-/N 40.001.509.00

Varianten: Der Austausch von Zugknöpfen und/oder beschichteten Ventilbestandteilen erfolgt mittels Variantencode. Mehr Infos siehe Seite 395.  
Varianti: La sostituzione di pomoli e/o componenti piletta rivestiti avviene mediante codice variante. Per maggiori informazioni, vedere pag. 395.



**DEC-Beschichtung, schwarz matt**  
**Rivestimento a DEC, nero opaco**  
**3 1/2" TouchFlow**  
CHF 140.-/F 40.002.991.02

**DEC-Beschichtung, schwarz matt**  
**Rivestimento a DEC, nero opaco**  
**3 1/2" Raumspar/ Salvaspazio**  
CHF 140.-/F 40.002.992.02

**DEC-Beschichtung, schwarz matt**  
**Rivestimento a DEC, nero opaco**  
**3 1/2" Tipo**  
CHF 140.-/F 40.002.993.02

**Mehrpreis für beschichtete Ventilbestandteile**  
Siebeinsatz, Überlaufblende und Überlaufkappe  
**Sovraprezzo per componenti piletta rivestiti**  
Griglietta, mascherina e tappo di troppopieno

Preis CHF / Prezzo in CHF

Modell Modello	Material Materiale	Ventil sFlow, Typ M Piletta sFlow, tipo M	Artikel-Nr. N. di articolo	Beckentiefe Profondità	Exkl. MWST IVA esclusa	Inkl. MWST IVA inclusa	VRG TRA	
<b>LIO CD 50U Ausführung für 60-er Unterschrank / LIO CD 50U versione per una base di 60 cm</b>								
<b>Linero LIO CD 50U/1</b>	Cristadur, Puro	3 1/2" TouchFlow	10.105.561.00	165 mm	B	1427.–	1543.–	0,19
		3 1/2" Druckknopf Pulsante	10.106.246.00	165 mm	B	1274.–	1377.–	
		3 1/2" Raumspar Salvaspazio	10.105.562.00	165 mm	B	1229.–	1329.–	
		3 1/2" Tipo	10.105.563.00	165 mm	B	1188.–	1284.–	
	Cristadur, Stone	3 1/2" TouchFlow	10.105.569.00	165 mm	B	1427.–	1543.–	0,19
		3 1/2" Druckknopf Pulsante	10.106.247.00	165 mm	B	1274.–	1377.–	
		3 1/2" Raumspar Salvaspazio	10.105.570.00	165 mm	B	1229.–	1329.–	
		3 1/2" Tipo	10.105.571.00	165 mm	B	1188.–	1284.–	
	Cristadur, Polaris	3 1/2" TouchFlow	10.105.573.00	165 mm	B	1427.–	1543.–	0,19
		3 1/2" Druckknopf Pulsante	10.106.248.00	165 mm	B	1274.–	1377.–	
		3 1/2" Raumspar Salvaspazio	10.105.574.00	165 mm	B	1229.–	1329.–	
		3 1/2" Tipo	10.105.575.00	165 mm	B	1188.–	1284.–	

<b>LIO CD 50U Ausführung für 55-er Unterschrank / LIO CD 50U versione per una base di 55 cm</b>								
<b>Linero LIO CD 50U/2</b>	Cristadur, Puro	3 1/2" TouchFlow	10.105.577.00	165 mm	B	1495.–	1616.–	0,19
		3 1/2" Druckknopf Pulsante	10.106.249.00	165 mm	B	1342.–	1451.–	
		3 1/2" Raumspar Salvaspazio	10.105.578.00	165 mm	B	1297.–	1402.–	
		3 1/2" Tipo	10.105.579.00	165 mm	B	1256.–	1358.–	
	Cristadur, Stone	3 1/2" TouchFlow	10.105.585.00	165 mm	B	1495.–	1616.–	0,19
		3 1/2" Druckknopf Pulsante	10.106.250.00	165 mm	B	1342.–	1451.–	
		3 1/2" Raumspar Salvaspazio	10.105.586.00	165 mm	B	1297.–	1402.–	
		3 1/2" Tipo	10.105.587.00	165 mm	B	1256.–	1358.–	
	Cristadur, Polaris	3 1/2" TouchFlow	10.105.589.00	165 mm	B	1495.–	1616.–	0,19
		3 1/2" Druckknopf Pulsante	10.106.251.00	165 mm	B	1342.–	1451.–	
		3 1/2" Raumspar Salvaspazio	10.105.590.00	165 mm	B	1297.–	1402.–	
		3 1/2" Tipo	10.105.591.00	165 mm	B	1256.–	1358.–	

Linero LIO CD 50U/2 für 55-er Unterschrank  
Linero LIO CD 50U/2 per una base di 55



Erfordert beidseitigen Ausschnitt der Korpuswand.  
Richiede un intaglio della parete dell'armadio su entrambi i lati.

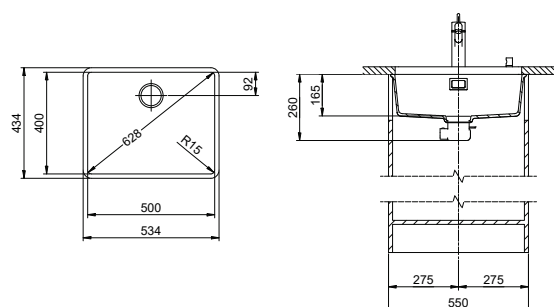

Zeichnung als pdf / dxf und Montageanleitung siehe:  
V. disegno in formato pdf / dxf e montaggio:  
suter.ch

## Linero: LIO CD 50U

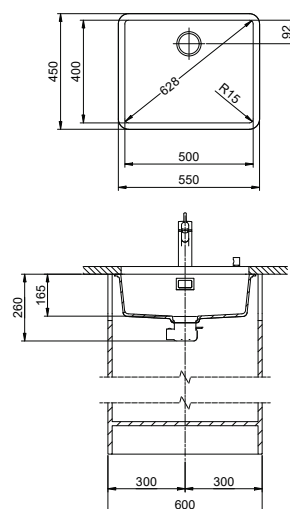
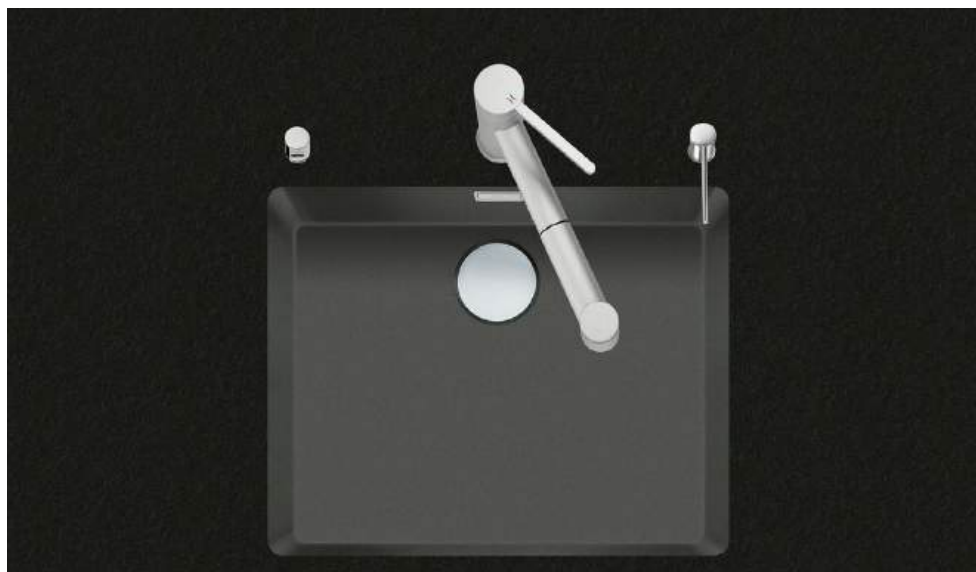
SCHOCK  
CRISTADUR®

Schwenkbare Überlaufkappe  
Placchetta di troppopieno a ribalta

15

Desino: Verdeckter Ablauf mit untenliegendem Korb  
Desino: Scarico coperto con griglietta inferiore

14



Für TouchFlow Desino, Raumspar Desino und Tipo Desino  
Per TouchFlow Desino, Salvaspazio Desino e Tipo Desino

Für TouchFlow Desino, Raumspar Desino und Tipo Desino  
Per TouchFlow Desino, Salvaspazio Desino e Tipo Desino

Zeichnung als pdf / dxf und Montageanleitung siehe:  
V. disegno in formato pdf / dxf e montaggio:  
suter.ch

## Optionales Zubehör/Accessori opzionali

312



**Resteschale** gelocht  
**Vaschetta** forato

CHF 106.– 40.000.912.00



**Resteschale** ungelocht  
**Vaschetta** non forato

CHF 106.– 40.001.289.00



**Schneidebrett** aus Glas  
**Tagliere** in vetro

CHF 151.– 40.000.909.00



**Schneidebrett** aus Kunststoff  
**Tagliere** sintetico

CHF 151.– 40.001.277.00

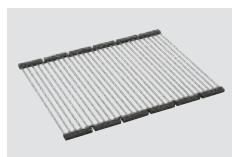

**Inox Pad**

CHF 125.– 40.001.138.00



**Reinigungsset Easy Care**  
**Kit di pulizia Easy Care**

CHF 29.–/N 40.001.509.00

Varianten: Der Austausch von Zugknöpfen und/oder beschichteten Ventilbestandteilen erfolgt mittels Variantencode. Mehr Infos siehe Seite 395.  
Varianti: La sostituzione di pomoli e/o componenti piletta rivestiti avviene mediante codice variante.  
Per maggiori informazioni, vedere pag. 395.



**DEC-Beschichtung, schwarz matt**  
**Rivestimento a DEC, nero opaco**  
**3 1/2" TouchFlow Desino**

CHF 140.–/F 40.002.789.02



**DEC-Beschichtung, schwarz matt**  
**Rivestimento a DEC, nero opaco**  
**3 1/2" Raumspar Desino / Salvaspazio Desino**

CHF 140.–/F 40.002.768.02















**DEC-Beschichtung, schwarz matt**  
**Rivestimento a DEC, nero opaco**  
**3 1/2" Tipo Desino**













CHF 140.–/F 40.002.996.02

**Mehrpreis für beschichtete Ventilbestandteile**  
TouchFlow Desino, Raumspar Desino und Tipo Desino: Ablaufsieb Desino, Überlaufblende und Überlaufkappe

**Sovrapprezzo per componenti piletta rivestiti**  
TouchFlow Desino, Salvaspazio Desino und Tipo Desino: griglietta per lo scarico Desino, mascherina e tappo di troppopieno

Preis CHF/Prezzo in CHF

Modell Modello	Material Materiale	Ventil sFlow, Typ M Piletta sFlow, tipo M	Artikel-Nr. N. di articolo	Beckentiefe Profondità	Exkl. MWST IVA esclusa	Inkl. MWST IVA inclusa	VRG TRA	
<b>LIO CD 50U Ausführung für 60-er Unterschrank / LIO CD 50U versione per una base di 60 cm</b>								
<b>Linero LIO CD 50U/1</b>		3 1/2" TouchFlow Desino	10.105.282.00 	165 mm	B	1579.–	1707.–	0,19
		3 1/2" Raumspar Desino Salvaspazio Desino	10.105.283.00 	165 mm	B	1369.–	1480.–	
		3 1/2" Tipo Desino	10.105.560.00 	165 mm	B	1369.–	1480.–	
		3 1/2" TouchFlow Desino	10.105.294.00 	165 mm	B	1579.–	1707.–	0,19
		3 1/2" Raumspar Desino Salvaspazio Desino	10.105.295.00 	165 mm	B	1369.–	1480.–	
		3 1/2" Tipo Desino	10.105.568.00 	165 mm	B	1369.–	1480.–	
		3 1/2" TouchFlow Desino	10.105.284.00 	165 mm	B	1579.–	1707.–	0,19
		3 1/2" Raumspar Desino Salvaspazio Desino	10.105.285.00 	165 mm	B	1369.–	1480.–	
		3 1/2" Tipo Desino	10.105.572.00 	165 mm	B	1369.–	1480.–	

<b>LIO CD 50U Ausführung für 55-er Unterschrank / LIO CD 50U versione per una base di 55 cm</b>								
<b>Linero LIO CD 50U/2</b>		3 1/2" TouchFlow Desino	10.105.310.00 	165 mm	B	1647.–	1780.–	0,19
		3 1/2" Raumspar Desino Salvaspazio Desino	10.105.311.00 	165 mm	B	1437.–	1553.–	
		3 1/2" Tipo Desino	10.105.576.00 	165 mm	B	1437.–	1553.–	
		3 1/2" TouchFlow Desino	10.105.314.00 	165 mm	B	1647.–	1780.–	0,19
		3 1/2" Raumspar Desino Salvaspazio Desino	10.105.315.00 	165 mm	B	1437.–	1553.–	
		3 1/2" Tipo Desino	10.105.584.00 	165 mm	B	1437.–	1553.–	
		3 1/2" TouchFlow Desino	10.105.312.00 	165 mm	B	1647.–	1780.–	0,19
		3 1/2" Raumspar Desino Salvaspazio Desino	10.105.313.00 	165 mm	B	1437.–	1553.–	
		3 1/2" Tipo Desino	10.105.588.00 	165 mm	B	1437.–	1553.–	

Linero LIO CD 50U/2 für 55-er Unterschrank  
Linero LIO CD 50U/2 per una base di 55



Erfordert beidseitigen Ausschnitt der Korpuswand.  
Richiede un intaglio della parete dell'armadio su entrambi i lati.

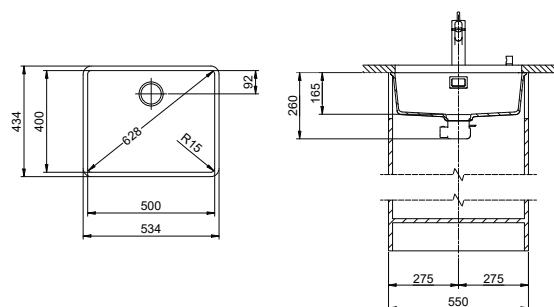

Zeichnung als pdf / dxf und Montageanleitung siehe:  
V. disegno in formato pdf / dxf e montaggio:  
suter.ch

## Linero: LIO CDAB 50U Black Edition

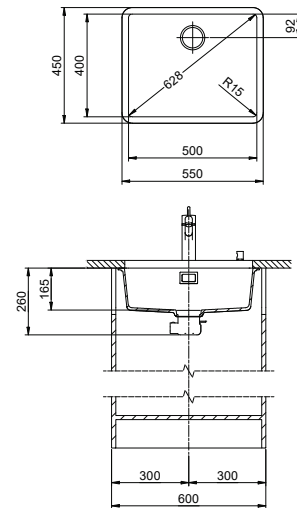
SCHOCK  
CRISTADUR®

 Schwenkbare Überlaufkappe  
Placchetta di troppopieno a ribalta

15

 Obenliegendes Sieb  
Griglietta superiore

14



Zeichnung als pdf/ dxf und Montageanleitung siehe:  
V. disegno in formato pdf/ dxf e montaggio:  
suter.ch

## Optionales Zubehör/Accessori opzionali

312

**Resteschale** gelocht  
**Vaschetta** forato  
CHF 106.– 40.000.912.00

**Resteschale** ungelocht  
**Vaschetta** non forato  
CHF 106.– 40.001.289.00

**Schneidebrett** aus Glas  
**Tagliere** in vetro  
CHF 151.– 40.000.909.00

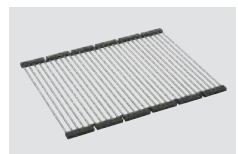
**Schneidebrett** aus Kunststoff  
**Tagliere** sintetico  
CHF 151.– 40.001.277.00

**Inox Pad**  
CHF 125.– 40.001.138.00

**Reinigungsset Easy Care**  
**Kit di pulizia Easy Care**  
CHF 29.–/N 40.001.509.00

**DEC-Beschichtung, schwarz matt**  
Rivestimento a DEC, nero opaco  
**3 1/2" TouchFlow**
**DEC-Beschichtung, schwarz matt**  
Rivestimento a DEC, nero opaco  
**3 1/2" Raumspas / Salvaspazio**
**DEC-Beschichtung, schwarz matt**  
Rivestimento a DEC, nero opaco  
**3 1/2" Tipo**
**Beschichtete Ventilbestandteile: im Preis inbegriffen**

TouchFlow, Raumspas und Tipo: Siebeinsatz, Überlaufblende und Überlaufkappe  
Raumspas: bei der Black Edition ist der Zugknopf Advant (pulverbeschichtet, schwarz, matt) im Preis und Lieferumfang enthalten

**Componenti piletta rivestiti: inclusi nel prezzo**

TouchFlow, Salvaspazio e Tipo: griglietta, mascherina e tappo di troppopieno  
Salvaspazio: La Black Edition comprende il pomolo Advant (rivestimento con polvere, nero, opaco) nel prezzo e nel corredo di fornitura

Preis CHF/Prezzo in CHF

Modell Modello	Material Materiale	Ventil sFlow, Typ M Piletta sFlow, tipo M	Artikel-Nr. N. di articolo	Beckentiefe Profondità	Exkl. MWST IVA esclusa	Inkl. MWST IVA inclusa	VRG TRA	
<b>LIO CDAB 50U Black Edition Ausführung für 60-er Unterschrank / LIO CDAB 50U Black Edition versione per una base di 60 cm</b>								
<b>Linero LIO CDAB 50U/1 Black Edition</b>	Cristadur, Puro	3 1/2" TouchFlow	10.105.561.50	165 mm	B	1607.–	1737.–	0,19
		3 1/2" Druckknopf Pulsante	10.106.246.50	165 mm	B	1454.–	1572.–	
		3 1/2" Raumspar Salvaspazio	10.105.562.50	165 mm	B	1409.–	1523.–	
		3 1/2" Tipo	10.105.563.50	165 mm	B	1368.–	1479.–	
<b>LIO CDAB 50U Black Edition Ausführung für 55-er Unterschrank / LIO CDAB 50U Black Edition versione per una base di 55 cm</b>								
<b>Linero LIO CDAB 50U/2 Black Edition</b>	Cristadur, Puro	3 1/2" TouchFlow	10.105.577.50	165 mm	B	1675.–	1811.–	0,19
		3 1/2" Druckknopf Pulsante	10.106.249.50	165 mm	B	1522.–	1645.–	
		3 1/2" Raumspar Salvaspazio	10.105.578.50	165 mm	B	1477.–	1597.–	
		3 1/2" Tipo	10.105.579.50	165 mm	B	1436.–	1552.–	

Linero LIO CDAB 50U/2 Black Edition für 55-er Unterschrank  
 Linero LIO CDAB 50U/2 Black Edition per una base di 55



Erfordert beidseitigen Ausschnitt der Korpuswand.  
 Richiede un intaglio della parete dell'armadio su entrambi i lati.

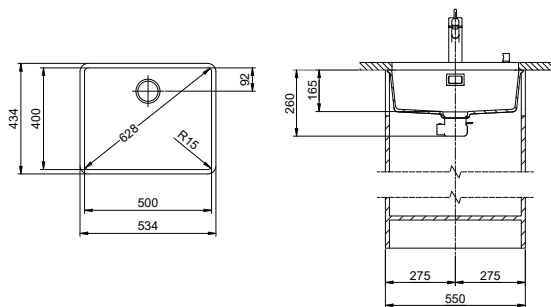

Zeichnung als pdf / dxf und Montageanleitung siehe:  
 V. disegno in formato pdf / dxf e montaggio:  
 suter.ch

# Linero: LIO CDAB 50U Black Edition

**SCHOCK**  
CRISTADUR®

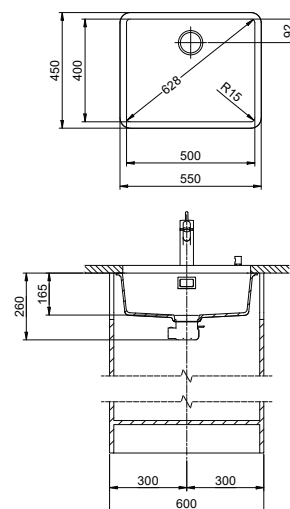

Schwenkbare Überlaufkappe  
Placchetta di troppopieno a ribalta

15

Desino: Verdeckter Ablauf mit untenliegendem Korb  
Desino: Scarico coperto con griglietta inferiore

14



Für TouchFlow Desino, Raumspar Desino und Tipo Desino  
Per TouchFlow Desino, Salvaspazio Desino e Tipo Desino

Für TouchFlow Desino, Raumspar Desino und Tipo Desino  
Per TouchFlow Desino, Salvaspazio Desino e Tipo Desino

Zeichnung als pdf / dxf und Montageanleitung siehe:  
V. disegno in formato pdf / dxf e montaggio:  
suter.ch

## Optionales Zubehör/Accessori opzionali

312



**Resteschale gelocht**  
**Vaschetta forata**  
CHF 106.- 40.000.912.00



**Resteschale ungelocht**  
**Vaschetta non forata**  
CHF 106.- 40.001.289.00



**Schneidebrett aus Glas**  
**Tagliere in vetro**  
CHF 151.- 40.000.909.00



**Schneidebrett aus Kunststoff**  
**Tagliere sintetico**  
CHF 151.- 40.001.277.00

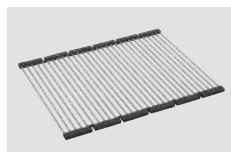

**Inox Pad**  
CHF 125.- 40.001.138.00



**Reinigungsset Easy Care**  
**Kit di pulizia Easy Care**  
CHF 29.-/N 40.001.509.00



**DEC-Beschichtung, schwarz matt**  
**Rivestimento a DEC, nero opaco**  
**3 1/2" TouchFlow Desino**



**DEC-Beschichtung, schwarz matt**  
**Rivestimento a DEC, nero opaco**  
**3 1/2" Raumspar Desino / Salvaspazio Desino**









**DEC-Beschichtung, schwarz matt**  
**Rivestimento a DEC, nero opaco**  
**3 1/2" Tipo Desino**

**i Beschichtete Ventilbestandteile: im Preis inbegriffen**  
TouchFlow Desino, Raumspar Desino und Tipo Desino: Ablaufsieb Desino, Überlaufblende und Überlaufkappe  
Raumspar Desino: bei der Black Edition ist der Zugknopf Advant (pulverbeschichtet, schwarz, matt) im Preis und Lieferumfang enthalten

**Componenti piletta rivestiti: inclusi nel prezzo**  
TouchFlow Desino, Salvaspazio Desino e Tipo Desino: griglietta per lo scarico Desino, mascherina e tappo di troppopieno  
Salvaspazio Desino: La Black Edition comprende il pomolo Advant (rivestimento con polvere, nero, opaco) nel prezzo e nel corredo di fornitura

Preis CHF/Prezzo in CHF

Modell Modello	Material Materiale	Ventil sFlow, Typ M Piletta sFlow, tipo M	Artikel-Nr. N. di articolo	Beckentiefe Profondità	Exkl. MWST IVA esclusa	Inkl. MWST IVA inclusa	VRG TRA	
<b>LIO CDAB 50U Black Edition Ausführung für 60-er Unterschrank / LIO CDAB 50U Black Edition versione per una base di 60 cm</b>								
<b>Linero LIO CDAB 50U/1 Black Edition</b>	Cristadur, Puro	3 1/2" TouchFlow Desino	10.105.282.50 	165 mm	B	1759.–	1901.–	0.19
		3 1/2" Raumspar Desino Salvaspazio Desino	10.105.283.50 	165 mm	B	1549.–	1674.–	
		3 1/2" Tipo Desino	10.105.560.50 	165 mm	B	1549.–	1674.–	
<b>LIO CDAB 50U Black Edition Ausführung für 55-er Unterschrank / LIO CDAB 50U Black Edition versione per una base di 55 cm</b>								
<b>Linero LIO CDAB 50U/2 Black Edition</b>	Cristadur, Puro	3 1/2" TouchFlow Desino	10.105.310.50 	165 mm	B	1827.–	1975.–	0.19
		3 1/2" Raumspar Desino Salvaspazio Desino	10.105.311.50 	165 mm	B	1617.–	1748.–	
		3 1/2" Tipo Desino	10.105.576.50 	165 mm	B	1617.–	1748.–	

Linero LIO CDAB 50U/2 Black Edition für 55-er Unterschrank  
Linero LIO CDAB 50U/2 Black Edition per una base di 55



Erfordert beidseitigen Ausschnitt der Korpuswand.  
Richiede un intaglio della parete dell'armadio su entrambi i lati.

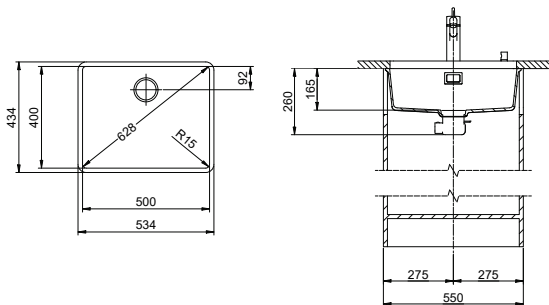

Zeichnung als pdf / dxf und Montageanleitung siehe:  
V. disegno in formato pdf / dxf e montaggio:  
suter.ch

## Daneo: DAN CP 45U

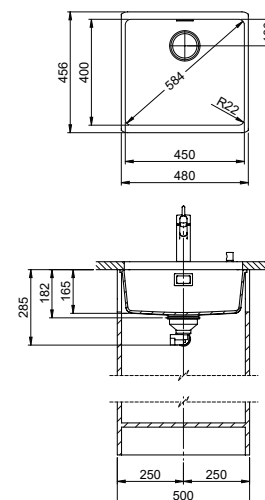
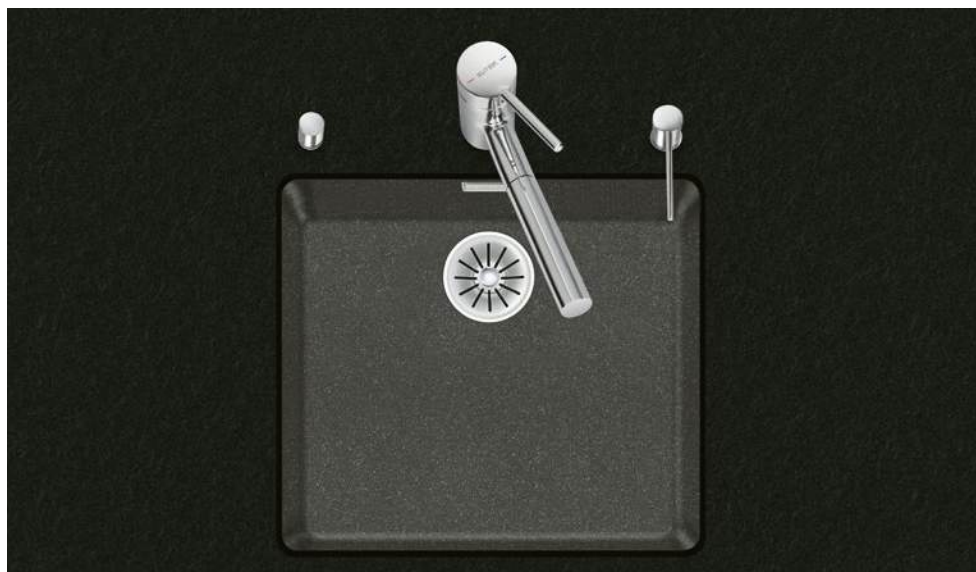
SCHOCK  
CRISTALITE®

 Schwenkbare Überlaufkappe  
Placchetta di troppopieno a ribalta

15

 Obenliegendes Sieb  
Griglietta superiore

14



Zeichnung als pdf/dxf und Montageanleitung siehe:  
V. disegno in formato pdf/dxf e montaggio:  
suter.ch

## Optionales Zubehör/Accessori opzionali

312



**Resteschale gelocht**  
**Vaschetta forato**  
CHF 106.– 40.000.912.00

**Resteschale ungelocht**  
**Vaschetta non forato**  
CHF 106.– 40.001.289.00

**Schneidebrett aus Glas**  
**Tagliere in vetro**  
CHF 151.– 40.000.909.00

**Schneidebrett aus Kunststoff**  
**Tagliere sintetico**  
CHF 151.– 40.001.277.00

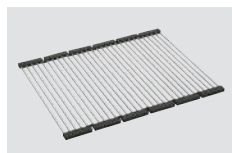
Erfordert beidseitigen Ausschnitt der Korpuswand.  
Richiede un intaglio della parete dell'armadio su entrambi  
i lati.

**Inox Pad**  
CHF 125.– 40.001.138.00

**Reinigungsset Easy Care**  
**Kit di pulizia Easy Care**  
CHF 29.–/N 40.001.509.00

**!** Varianten: Der Austausch von Zugknöpfen und/oder beschichteten Ventilbestandteilen erfolgt mittels Variantencode.  
Mehr Infos siehe Seite 395.  
Varianti: La sostituzione di pomoli e/o componenti piletta rivestiti avviene mediante codice variante.  
Per maggiori informazioni, vedere pag. 395.

**DEC-Beschichtung, schwarz matt**  
**Rivestimento a DEC, nero opaco**  
**3 1/2" TouchFlow**  
CHF 197.–/F 40.002.559.02

**DEC-Beschichtung, schwarz matt**  
**Rivestimento a DEC, nero opaco**  
**3 1/2" Raumspar / Salvaspazio**  
CHF 197.–/F 40.002.560.02

**DEC-Beschichtung, schwarz matt**  
**Rivestimento a DEC, nero opaco**  
**3 1/2" Tipo**  
CHF 197.–/F 40.002.561.02





























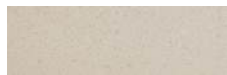

**Mehrprijs für beschichtete Ventilbestandteile**  
TouchFlow und Raumspar: Stößel, Ventilkelch, Siebeinsatz, Überlaufblende und Überlaufkappe  
Tipo: Tipo-Siebstopfen, Ventilkelch, Überlaufblende und Überlaufkappe

**Sovrapprezzo per componenti piletta color nero con rivestimento**

TouchFlow und salvaspazio: Tappo, tazza, griglietta, mascherina e tappo di troppopieno

Tipo: Tipo a tappo c. griglietta, tazza, mascherina e tappo di troppopieno

Preis CHF / Prezzo in CHF

Modell Modello	Material Materiale	Ventil Piletta	Artikel-Nr. N. di articolo	Beckentiefe Profondità	Exkl. MWST IVA esclusa	Inkl. MWST IVA inclusa	VRG TRA	
<b>Daneo DAN CP 45U</b>	Cristalite Plus, Nero 	3 1/2" TouchFlow	10.104.734.00 	165 mm	B	1237.–	1337.–	0.19
		3 1/2" Raumspaar Salvaspazio	10.104.735.00 	165 mm	B	1039.–	1123.–	
		3 1/2" Tipo	10.104.736.00 	165 mm	B	998.–	1079.–	
	Cristalite Plus, Asphalt 	3 1/2" TouchFlow	10.104.749.00 	165 mm	B	1237.–	1337.–	0.19
		3 1/2" Raumspaar Salvaspazio	10.104.750.00 	165 mm	B	1039.–	1123.–	
		3 1/2" Tipo	10.104.751.00 	165 mm	B	998.–	1079.–	
	Cristalite Plus, Mocha 	3 1/2" TouchFlow	10.104.743.00  	165 mm	B	1237.–	1337.–	0.19
		3 1/2" Raumspaar Salvaspazio	10.104.744.00  	165 mm	B	1039.–	1123.–	
		3 1/2" Tipo	10.104.745.00  	165 mm	B	998.–	1079.–	
	Cristalite Plus, Cromo 	3 1/2" TouchFlow	10.104.740.00  	165 mm	B	1237.–	1337.–	0.19
		3 1/2" Raumspaar Salvaspazio	10.104.741.00  	165 mm	B	1039.–	1123.–	
		3 1/2" Tipo	10.104.742.00  	165 mm	B	998.–	1079.–	
	Cristalite Plus, Everest 	3 1/2" TouchFlow	10.104.746.00 	165 mm	B	1237.–	1337.–	0.19
		3 1/2" Raumspaar Salvaspazio	10.104.747.00 	165 mm	B	1039.–	1123.–	
		3 1/2" Tipo	10.104.748.00 	165 mm	B	998.–	1079.–	
Cristalite Plus, Alpina/Superwhite 	3 1/2" TouchFlow	10.104.737.00 	165 mm	B	1237.–	1337.–	0.19	
	3 1/2" Raumspaar Salvaspazio	10.104.738.00 	165 mm	B	1039.–	1123.–		
	3 1/2" Tipo	10.104.739.00 	165 mm	B	998.–	1079.–		

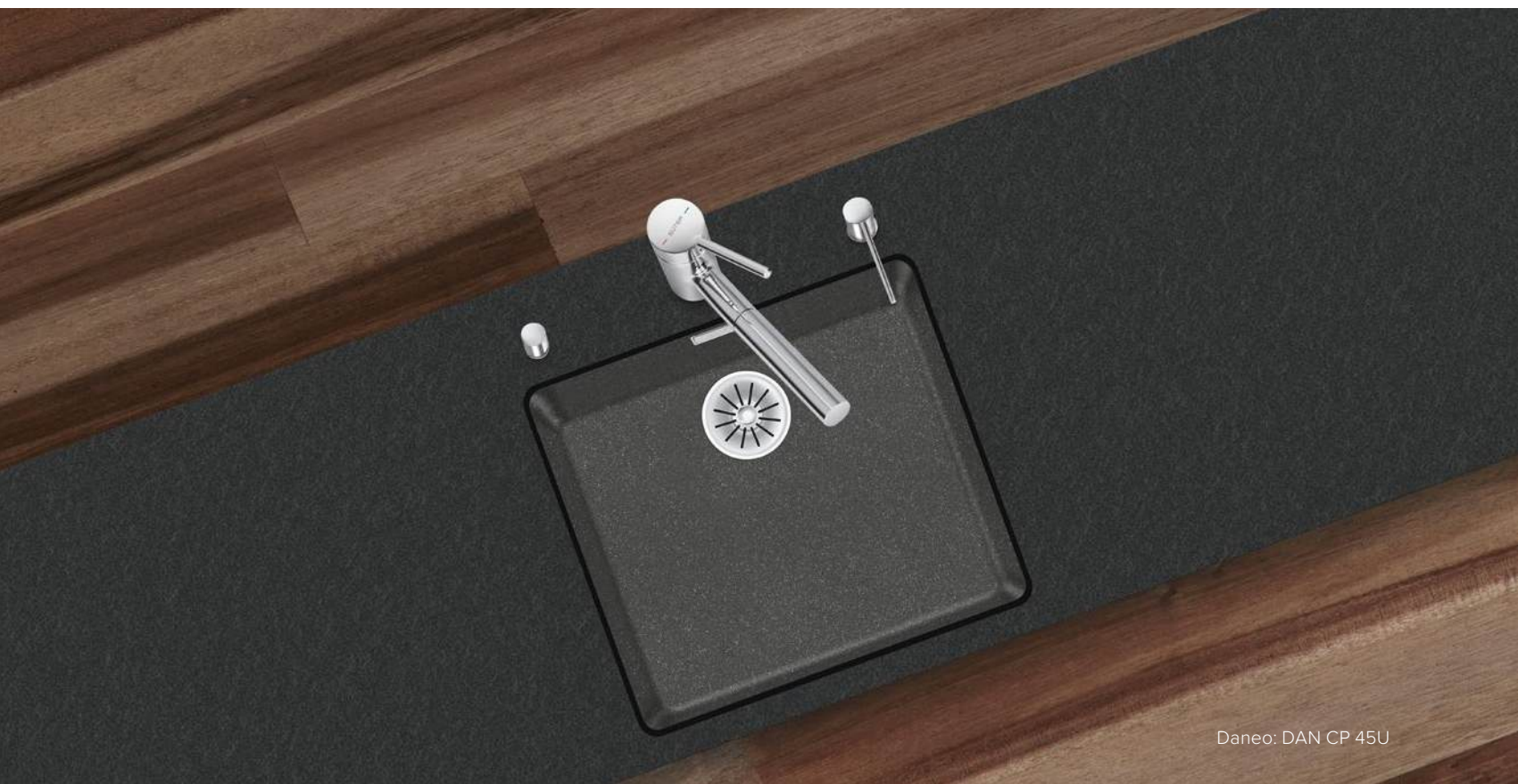

Daneo: DAN CP 45U

Daneo: DAN CP 50U

SCHOCK  
CRISTALITE®

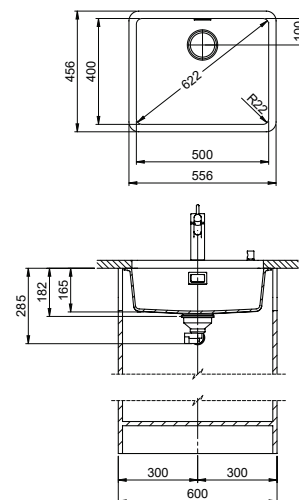
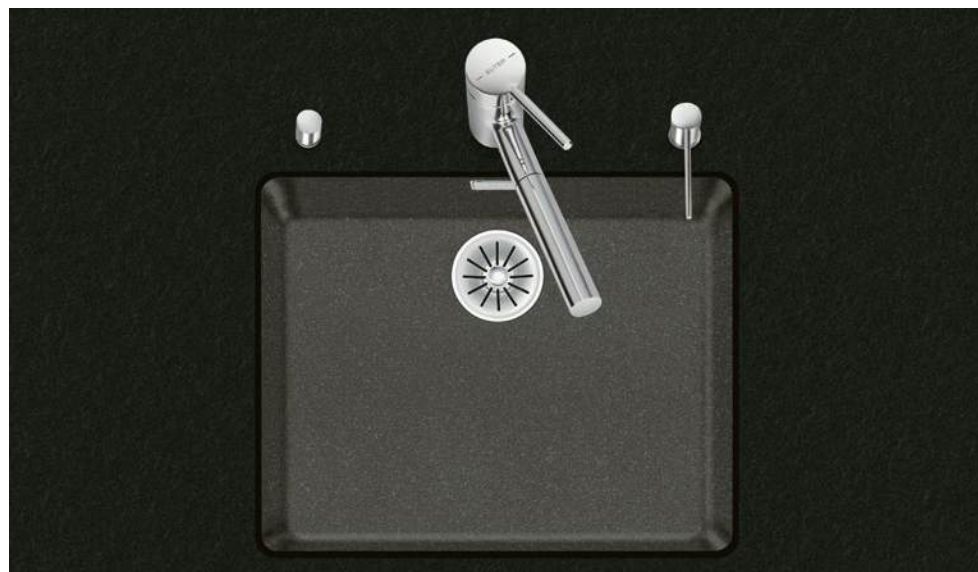

Schwenkbare Überlaufkappe  
Placchetta di troppieno a ribalta



Obenliegendes Sieb  
Griglietta superiore



Zeichnung als pdf / dxf und Montageanleitung siehe:  
V. disegno in formato pdf / dxf e montaggio:  
suter.ch

Optionales Zubehör/Accessori opzionali



Resteschale gelocht  
Vaschetta forato  
CHF 106.- 40.000.912.00

Resteschale ungelocht  
Vaschetta non forato  
CHF 106.- 40.001.289.00

Schneidebrett aus Glas  
Tagliere in vetro  
CHF 151.- 40.000.909.00

Schneidebrett aus Kunststoff  
Tagliere sintetico  
CHF 151.- 40.001.277.00

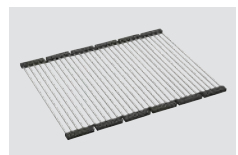

Inox Pad  
CHF 125.- 40.001.138.00



Reinigungsset Easy Care  
Kit di pulizia Easy Care  
CHF 29.-/N 40.001.509.00

! Varianten: Der Austausch von Zugknöpfen und/oder beschichteten Ventilbestandteilen erfolgt mittels Variantencode. Mehr Infos siehe Seite 395.  
Varianti: La sostituzione di pomoli e/o componenti piletta rivestiti avviene mediante codice variante. Per maggiori informazioni, vedere pag. 395.



DEC-Beschichtung, schwarz matt  
Rivestimento a DEC, nero opaco  
3 1/2" TouchFlow  
CHF 197.-/F 40.002.559.02























DEC-Beschichtung, schwarz matt  
Rivestimento a DEC, nero opaco  
3 1/2" Raumspar / Salvaspazio  
CHF 197.-/F 40.002.560.02

DEC-Beschichtung, schwarz matt  
Rivestimento a DEC, nero opaco  
3 1/2" Tipo  
CHF 197.-/F 40.002.561.02



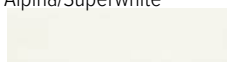













i Mehrpreis für beschichtete Ventilbestandteile  
TouchFlow und Raumspar: Stößel, Ventilkelch, Siebeinsatz, Überlaufblende und Überlaufkappe  
Tipo: Tipo-Siebstopfen, Ventilkelch, Überlaufblende und Überlaufkappe

Sovrapprezzo per componenti piletta color nero con rivestimento  
TouchFlow e salvaspazio: Tappo, tazza, griglietta, mascherina e tappo di troppieno  
Tipo: Tipo a tappo c. griglietta, tazza, mascherina e tappo di troppieno

Preis CHF / Prezzo in CHF

Modell Modello	Material Materiale	Ventil Piletta	Artikel-Nr. N. di articolo	Beckentiefe Profondità	Exkl. MWST IVA esclusa	Inkl. MWST IVA inclusa	VRG TRA	
<b>DAN CP 50U Ausführung für 60-er Unterschränk / DAN CP 50U versione per una base di 60 cm</b>								
<b>Daneo DAN CP 50U/1</b>	Cristalite Plus, Nero 	3 1/2" TouchFlow	10.104.752.00 	165 mm	B	1294.–	1399.–	0,19
		3 1/2" Raumsparsalvaspazio	10.104.753.00 	165 mm	B	1096.–	1185.–	
		3 1/2" Tipo	10.104.754.00 	165 mm	B	1055.–	1140.–	
	Cristalite Plus, Asphalt 	3 1/2" TouchFlow	10.104.767.00 	165 mm	B	1294.–	1399.–	0,19
		3 1/2" Raumsparsalvaspazio	10.104.768.00 	165 mm	B	1096.–	1185.–	
		3 1/2" Tipo	10.104.769.00 	165 mm	B	1055.–	1140.–	
	Cristalite Plus, Cromo 	3 1/2" TouchFlow	10.104.758.00  	165 mm	B	1294.–	1399.–	0,19
		3 1/2" Raumsparsalvaspazio	10.103.759.00  	165 mm	B	1096.–	1185.–	
		3 1/2" Tipo	10.103.760.00  	165 mm	B	1055.–	1140.–	
	Cristalite Plus, Everest 	3 1/2" TouchFlow	10.104.764.00 	165 mm	B	1294.–	1399.–	0,19
		3 1/2" Raumsparsalvaspazio	10.103.765.00 	165 mm	B	1096.–	1185.–	
		3 1/2" Tipo	10.103.766.00 	165 mm	B	1055.–	1140.–	
Cristalite Plus, Alpina/Superwhite 	3 1/2" TouchFlow	10.104.755.00 	165 mm	B	1294.–	1399.–	0,19	
	3 1/2" Raumsparsalvaspazio	10.104.756.00 	165 mm	B	1096.–	1185.–		
	3 1/2" Tipo	10.104.757.00 	165 mm	B	1055.–	1140.–		

**DAN CP 50U Ausführung für 55-er Unterschränk / DAN CP 50U versione per una base di 55 cm**

<b>Daneo DAN CP 50U/2</b>	Cristalite Plus, Nero 	3 1/2" TouchFlow	10.104.770.00 	165 mm	B	1349.–	1458.–	0,19
		3 1/2" Raumsparsalvaspazio	10.104.771.00 	165 mm	B	1151.–	1244.–	
		3 1/2" Tipo	10.104.772.00 	165 mm	B	1110.–	1200.–	
	Cristalite Plus, Asphalt 	3 1/2" TouchFlow	10.104.785.00 	165 mm	B	1349.–	1458.–	0,19
		3 1/2" Raumsparsalvaspazio	10.104.786.00 	165 mm	B	1151.–	1244.–	
		3 1/2" Tipo	10.104.787.00 	165 mm	B	1110.–	1200.–	
	Cristalite Plus, Everest 	3 1/2" TouchFlow	10.104.782.00 	165 mm	B	1349.–	1458.–	0,19
		3 1/2" Raumsparsalvaspazio	10.104.783.00 	165 mm	B	1151.–	1244.–	
		3 1/2" Tipo	10.104.784.00 	165 mm	B	1110.–	1200.–	
	Cristalite Plus, Alpina/Superwhite 	3 1/2" TouchFlow	10.104.773.00 	165 mm	B	1349.–	1458.–	0,19
		3 1/2" Raumsparsalvaspazio	10.104.774.00 	165 mm	B	1151.–	1244.–	
		3 1/2" Tipo	10.104.775.00 	165 mm	B	1110.–	1200.–	

Daneo DAN CP 50U/2 für 55-er Unterschränk  
Daneo DAN CP 50U/2 per una base di 55

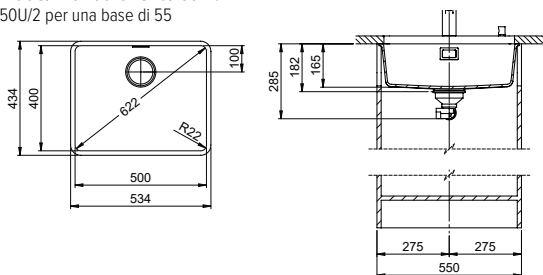

Erfordert beidseitigen Ausschnitt der Korpuswand.  
Richiede un intaglio della parete dell'armadio su entrambi i lati.

Zeichnung als pdf / dxf und Montageanleitung siehe:  
V. disegno in formato pdf / dxf e montaggio:  
suter.ch

## Daneo: DAN CP 55U

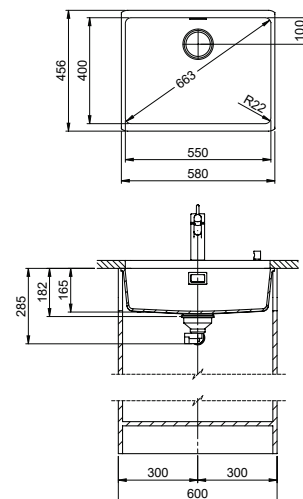
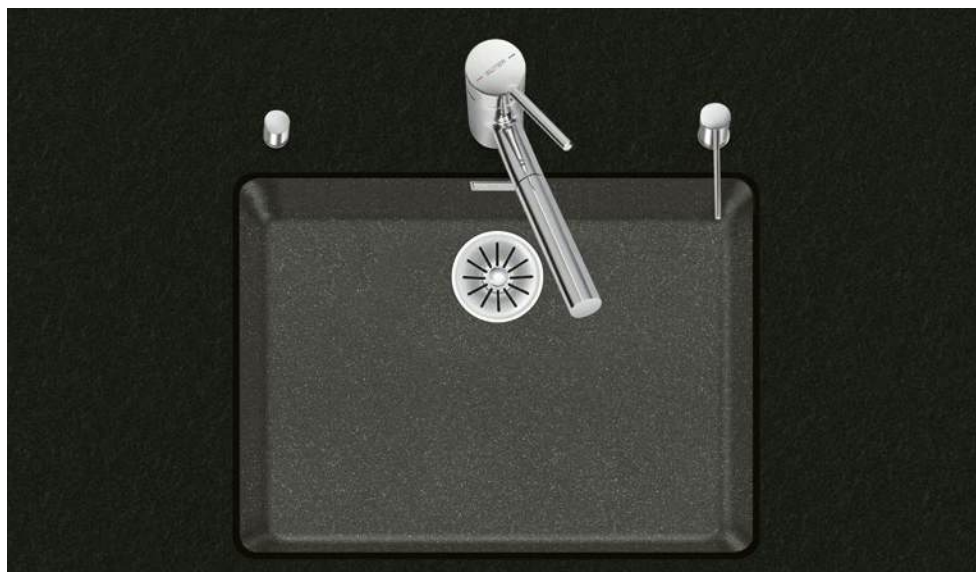
SCHOCK  
CRISTALITE®

 Schwenkbare Überlaufkappe  
Placchetta di troppopieno a ribalta

15

 Obenliegendes Sieb  
Griglietta superiore

14



Zeichnung als pdf/dxf und Montageanleitung siehe:  
V. disegno in formato pdf/dxf e montaggio:  
suter.ch

## Optionales Zubehör/Accessori opzionali

312

**Resteschale gelocht**  
**Vaschetta forato**  
CHF 106.– 40.000.912.00

**Resteschale ungelocht**  
**Vaschetta non forato**  
CHF 106.– 40.001.289.00

**Schneidebrett aus Glas**  
**Tagliere in vetro**  
CHF 151.– 40.000.909.00

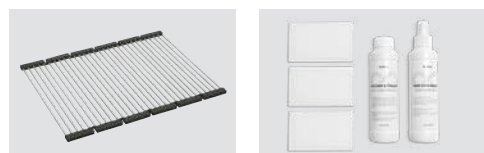
**Schneidebrett aus Kunststoff**  
**Tagliere sintetico**  
CHF 151.– 40.001.277.00

**Inox Pad**  
CHF 125.– 40.001.138.00

**Reinigungsset Easy Care**  
**Kit di pulizia Easy Care**  
CHF 29.–/N 40.001.509.00

 Erfordert beidseitigen Ausschnitt der Korpuswand.  
Richiede un intaglio della parete dell'armadio su entrambi  
i lati.

 Varianten: Der Austausch von Zugknöpfen und/oder beschichteten Ventilbestandteilen erfolgt mittels Variantencode.  
Mehr Infos siehe Seite 395.  
Varianti: La sostituzione di pomoli e/o componenti piletta rivestiti avviene mediante codice variante.  
Per maggiori informazioni, vedere pag. 395.

**DEC-Beschichtung, schwarz matt**  
**Rivestimento a DEC, nero opaco**  
**3 1/2" TouchFlow**  
CHF 197.–/F 40.002.559.02

**DEC-Beschichtung, schwarz matt**  
**Rivestimento a DEC, nero opaco**  
**3 1/2" Raumspar / Salvaspazio**  
CHF 197.–/F 40.002.560.02

**DEC-Beschichtung, schwarz matt**  
**Rivestimento a DEC, nero opaco**  
**3 1/2" Tipo**  
CHF 197.–/F 40.002.561.02































**Mehrprijs für beschichtete Ventilbestandteile**  
TouchFlow und Raumspar: Stößel, Ventilkelch, Siebeinsatz, Überlaufblende und Überlaufkappe  
Tipo: Tipo-Siebstopfen, Ventilkelch, Überlaufblende und Überlaufkappe

**Sovrapprezzo per componenti piletta color nero con rivestimento**

TouchFlow und salvaspazio: Tappo, tazza, griglietta, mascherina e tappo di troppopieno

Tipo: Tipo a tappo c. griglietta, tazza, mascherina e tappo di troppopieno

Preis CHF/Prezzo in CHF

Modell Modello	Material Materiale	Ventil Piletta	Artikel-Nr. N. di articolo	Beckentiefe Profondità	Exkl. MWST IVA esclusa	Inkl. MWST IVA inclusa	VRG TRA	
Daneo DAN CP 55U	Cristalite Plus, Nero 	3 1/2" TouchFlow	10.104.788.00 	165 mm	B	1458.–	1576.–	0.19
		3 1/2" Raumsparsalvaspazio	10.104.789.00 	165 mm	B	1260.–	1362.–	
		3 1/2" Tipo	10.104.790.00 	165 mm	B	1219.–	1318.–	
	Cristalite Plus, Asphalt 	3 1/2" TouchFlow	10.104.803.00 	165 mm	B	1458.–	1576.–	0.19
		3 1/2" Raumsparsalvaspazio	10.104.804.00 	165 mm	B	1260.–	1362.–	
		3 1/2" Tipo	10.104.805.00 	165 mm	B	1219.–	1318.–	
	Cristalite Plus, Mocha 	3 1/2" TouchFlow	10.104.797.00  	165 mm	B	1458.–	1576.–	0.19
		3 1/2" Raumsparsalvaspazio	10.104.798.00  	165 mm	B	1260.–	1362.–	
		3 1/2" Tipo	10.104.799.00  	165 mm	B	1219.–	1318.–	
	Cristalite Plus, Cromo 	3 1/2" TouchFlow	10.104.794.00  	165 mm	B	1458.–	1576.–	0.19
		3 1/2" Raumsparsalvaspazio	10.104.795.00  	165 mm	B	1260.–	1362.–	
		3 1/2" Tipo	10.104.796.00  	165 mm	B	1219.–	1318.–	
	Cristalite Plus, Everest 	3 1/2" TouchFlow	10.104.800.00 	165 mm	B	1458.–	1576.–	0.19
		3 1/2" Raumsparsalvaspazio	10.104.801.00 	165 mm	B	1260.–	1362.–	
		3 1/2" Tipo	10.104.802.00 	165 mm	B	1219.–	1318.–	
Cristalite Plus, Alpina/Superwhite 	3 1/2" TouchFlow	10.104.791.00 	165 mm	B	1458.–	1576.–	0.19	
	3 1/2" Raumsparsalvaspazio	10.104.792.00 	165 mm	B	1260.–	1362.–		
	3 1/2" Tipo	10.104.793.00 	165 mm	B	1219.–	1318.–		



Daneo: DAN CP 55U

## Brooklyn: BYK N 100S U

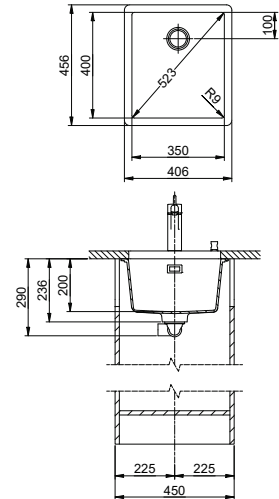
**SCHOCK**  
 CRISTALITE®

## Optionales Zubehör/Accessori opzionali

312

**Resteschale gelocht**  
**Vaschetta forato**  
 CHF 106.– 40.000.912.00

**Resteschale ungelocht**  
**Vaschetta non forato**  
 CHF 106.– 40.001.289.00

**Schneidebrett aus Glas**  
**Tagliere in vetro**  
 CHF 151.– 40.000.909.00

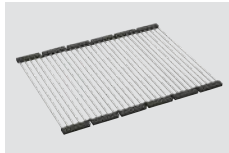
**Schneidebrett aus Kunststoff**  
**Tagliere sintetico**  
 CHF 151.– 40.001.277.00

**Inox Pad**  
 CHF 125.– 40.001.138.00

**Reinigungsset Easy Care**  
**Kit di pulizia Easy Care**  
 CHF 29.–/N 40.001.509.00

 Zeichnung als pdf/dxf und Montageanleitung siehe:  
 V. disegno in formato pdf/dxf e montaggio:  
 suter.ch

 Varianten: Der Austausch von Zugknöpfen erfolgt mittels Variantencode. Mehr Infos siehe Seite 395.  
 Varianti: La sostituzione di pomoli avviene mediante codice variante. Per maggiori informazioni, vedere pag. 395.

Preis CHF/Prezzo in CHF

Modell Modello	Material Materiale	Ventil Piletta	Artikel-Nr. N. di articolo	Beckentiefe Profondità	Exkl. MWST IVA esclusa	Inkl. MWST IVA inclusa
Brooklyn BYK N 100S U	Cristalite Plus, Nero	3 1/2" Raumsparsalvaspazio	10.104.321.00	200 mm	B 854.–	923.–
		3 1/2" Siebstopfen A tappo con griglietta	10.104.322.00	200 mm	B 813.–	879.–

Brooklyn: BYKAB N 100S U Black Edition

**SCHOCK**  
CRISTALITE®

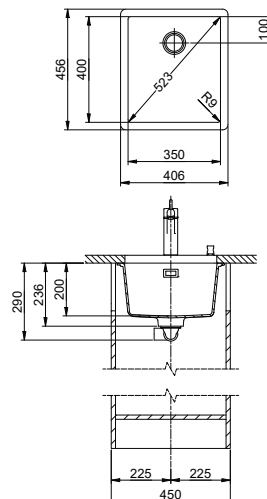

Optionales Zubehör/Accessori opzionali

312



**Resteschale** gelocht  
**Vaschetta** forato  
CHF 106.– 40.000.912.00



**Resteschale** ungelocht  
**Vaschetta** non forato  
CHF 106.– 40.001.289.00



**Schneidebrett** aus Glas  
**Tagliere** in vetro  
CHF 151.– 40.000.909.00



**Schneidebrett** aus Kunststoff  
**Tagliere** sintetico  
CHF 151.– 40.001.277.00

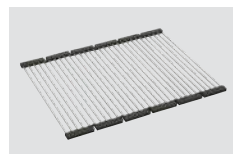

**Inox Pad**  
CHF 125.– 40.001.138.00



**Reinigungsset Easy Care**  
**Kit di pulizia Easy Care**  
CHF 29.–/N 40.001.509.00

Zeichnung als pdf / dxf und Montageanleitung siehe:  
V. disegno in formato pdf / dxf e montaggio:  
suter.ch

**i Beschichtete Ventilbestandteile:**  
**im Preis und Lieferumfang inbegriffen**  
Siebstopfen: Überlaufblende und Überlaufklappe,  
Ventilkelch und Sieb  
Raumspär: Überlaufblende und Überlaufklappe,  
Ventilkelch und Sieb, Zugknopf Prime in Kunststoff  
(schwarz matt)

**Componenti piletta rivestiti: inclusi nel prezzo e nel  
corredo di fornitura**  
Tappi con griglietta: mascherina di troppopieno e tappo di  
troppopieno, tazza e griglietta  
Salvaspazio: mascherina di troppopieno e tappo di troppopieno,  
tazza e griglietta, pomolo Prime in plastica (nero  
opaco)

**!** Varianten: Der Austausch von Zugknöpfen erfolgt mittels Variantencode. Mehr Infos siehe Seite 395.  
Varianti: La sostituzione di pomoli avviene mediante codice variante. Per maggiori informazioni, vedere pag. 395.

Preis CHF/Prezzo in CHF

Modell Modello	Material Materiale	Ventil Piletta	Artikel-Nr. N. di articolo	Beckentiefe Profondità	Exkl. MWST IVA esclusa	Inkl. MWST IVA inclusa
<b>Brooklyn BYKAB N 100S U Black Edition</b>	Cristalite Plus, Nero	3 1/2" Raumspär Salvaspazio	10.105.320.00 <b>L</b>	200 mm	B 894.–	966.–
		3 1/2" Siebstopfen A tappo con griglietta	10.105.321.00 <b>L</b>	200 mm	B 853.–	922.–

Brooklyn: BYK N 100U

SCHOCK  
CRISTALITE®

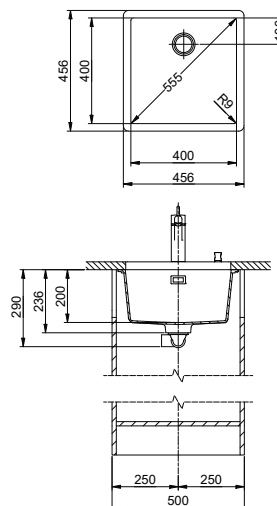

Unterbau-Becken  
Lavelli sottopiano

Optionales Zubehör/Accessori opzionali

312



**Resteschale gelocht**  
**Vaschetta forato**  
CHF 106.- 40.000.912.00



**Resteschale ungelocht**  
**Vaschetta non forato**  
CHF 106.- 40.001.289.00



**Schneidebrett aus Glas**  
**Tagliere in vetro**  
CHF 151.- 40.000.909.00



**Schneidebrett aus Kunststoff**  
**Tagliere sintetico**  
CHF 151.- 40.001.277.00

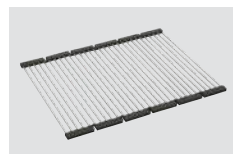

**Inox Pad**  
CHF 125.- 40.001.138.00



**Reinigungsset Easy Care**  
**Kit di pulizia Easy Care**  
CHF 29.-/N 40.001.509.00

Zeichnung als pdf / dxf und Montageanleitung siehe:  
V. disegno in formato pdf / dxf e montaggio:  
suter.ch

**!** Varianten: Der Austausch von Zugknöpfen erfolgt mittels Variantencode. Mehr Infos siehe Seite 395.  
Varianti: La sostituzione di pomoli avviene mediante codice variante. Per maggiori informazioni, vedere pag. 395.

Preis CHF/Prezzo in CHF

Modell Modello	Material Materiale	Ventil Piletta	Artikel-Nr. N. di articolo	Beckentiefe Profondità	Exkl. MWST IVA esclusa	Inkl. MWST IVA inclusa
Brooklyn BYK N 100U	Cristalite Plus, Nero	3 1/2" Raumsparsalvaspazio	10.103.292.00	200 mm	B 891.-	963.-
		3 1/2" Siebstopfen A tappo con griglietta	10.104.319.00	200 mm	B 850.-	919.-

Brooklyn: BYKAB N 100U Black Edition

SCHOCK  
CRISTALITE®

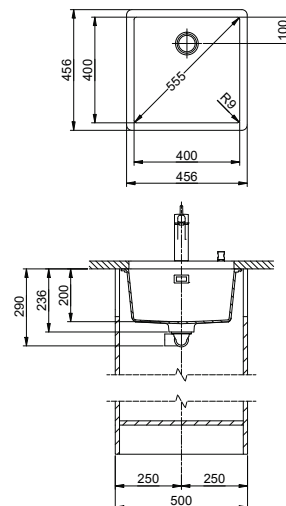
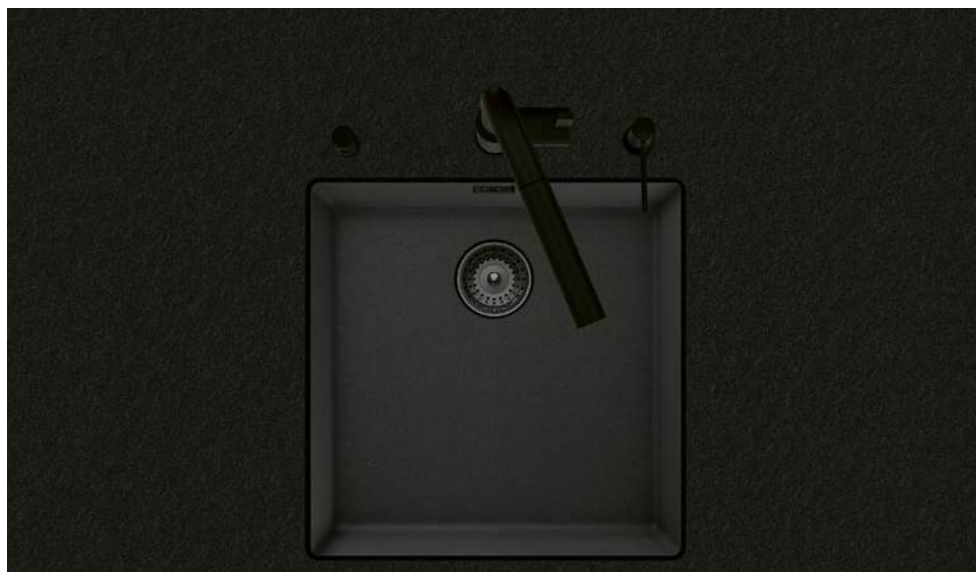

Optionales Zubehör/Accessori opzionali

312



**Resteschale gelocht**  
**Vaschetta forato**  
CHF 106.– 40.000.912.00



**Resteschale ungelocht**  
**Vaschetta non forato**  
CHF 106.– 40.001.289.00



**Schneidebrett aus Glas**  
**Tagliere in vetro**  
CHF 151.– 40.000.909.00



**Schneidebrett aus Kunststoff**  
**Tagliere sintetico**  
CHF 151.– 40.001.277.00

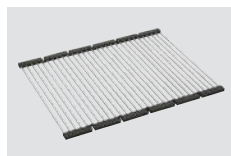

**Inox Pad**  
CHF 125.– 40.001.138.00



**Reinigungsset Easy Care**  
**Kit di pulizia Easy Care**  
CHF 29.–/N 40.001.509.00

Zeichnung als pdf/dxf und Montageanleitung siehe:  
V. disegno in formato pdf/dxf e montaggio:  
suter.ch

**i Beschichtete Ventilbestandteile:**  
**im Preis und Lieferumfang inbegriffen**  
Siebstopfen: Überlaufblende und Überlaufklappe,  
Ventilkelch und Sieb  
Raumspär: Überlaufblende und Überlaufklappe,  
Ventilkelch und Sieb, Zugknopf Prime in Kunststoff  
(schwarz matt)

**Componenti piletta rivestiti: inclusi nel prezzo e nel  
corredo di fornitura**  
Tappi con griglietta: mascherina di troppopieno e tappo di  
troppopieno, tazza e griglietta  
Salvaspazio: mascherina di troppopieno e tappo di troppopieno,  
tazza e griglietta, pomolo Prime in plastica (nero  
opaco)

**!** Varianten: Der Austausch von Zugknöpfen erfolgt mittels Variantencode. Mehr Infos siehe Seite 395.  
Varianti: La sostituzione di pomoli avviene mediante codice variante. Per maggiori informazioni, vedere pag. 395.

Preis CHF/Prezzo in CHF

Modell Modello	Material Materiale	Ventil Piletta	Artikel-Nr. N. di articolo	Beckentiefe Profondità	Exkl. MWST IVA esclusa	Inkl. MWST IVA inclusa
<b>Brooklyn BYKAB N 100 U Black Edition</b>	Cristalite Plus, Nero	3 1/2" Raumspär Salvaspazio	10.105.322.00 <b>L</b>	200 mm	B 931.–	1006.–
		3 1/2" Siebstopfen A tappo con griglietta	10.105.323.00 <b>L</b>	200 mm	B 890.–	962.–

## Brooklyn: BYK N 100L U

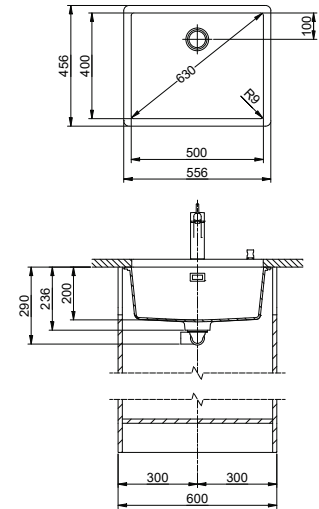
**SCHOCK**  
 CRISTALITE®

## Optionales Zubehör/Accessori opzionali

312

**Resteschale** gelocht  
**Vaschetta** forato  
 CHF 106.– 40.000.912.00

**Resteschale** ungelocht  
**Vaschetta** non forato  
 CHF 106.– 40.001.289.00

**Schneidebrett** aus Glas  
**Tagliere** in vetro  
 CHF 151.– 40.000.909.00

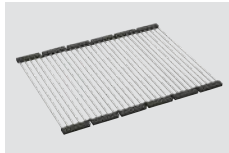
**Schneidebrett** aus Kunststoff  
**Tagliere** sintetico  
 CHF 151.– 40.001.277.00

**Inox Pad**  
 CHF 125.– 40.001.138.00

**Reinigungsset Easy Care**  
**Kit di pulizia Easy Care**  
 CHF 29.–/N 40.001.509.00

 Zeichnung als pdf / dxf und Montageanleitung siehe:  
 V. disegno in formato pdf / dxf e montaggio:  
 suter.ch

 Varianten: Der Austausch von Zugknöpfen erfolgt mittels Variantencode. Mehr Infos siehe Seite 395.  
 Varianti: La sostituzione di pomoli avviene mediante codice variante. Per maggiori informazioni, vedere pag. 395.

**Preis CHF/Prezzo in CHF**

Modell Modello	Material Materiale	Ventil Piletta	Artikel-Nr. N. di articolo	Beckentiefe Profondità	Exkl. MWST IVA esclusa	Inkl. MWST IVA inclusa
Brooklyn BYK N 100L U	Cristalite Plus, Nero	3 1/2" Raumspär Salvaspazio	10.103.298.00	200 mm	B 938.–	1014.–
		3 1/2" Siebstopfen A tappo con griglietta	10.104.320.00	200 mm	B 897.–	970.–

Brooklyn: BYKAB N 100L U Black Edition

**SCHOCK**  
CRISTALITE®

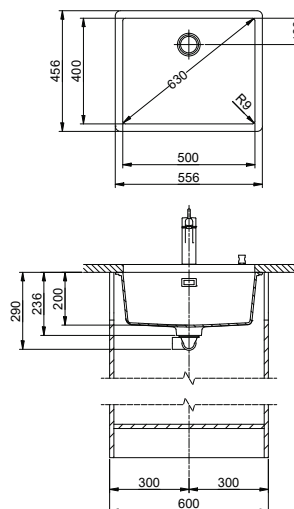

Optionales Zubehör/Accessori opzionali

312



**Resteschale gelocht**  
**Vaschetta forato**  
CHF 106.– 40.000.912.00



**Resteschale ungelocht**  
**Vaschetta non forato**  
CHF 106.– 40.001.289.00



**Schneidebrett aus Glas**  
**Tagliere in vetro**  
CHF 151.– 40.000.909.00



**Schneidebrett aus Kunststoff**  
**Tagliere sintetico**  
CHF 151.– 40.001.277.00

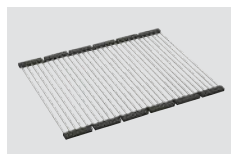

**Inox Pad**  
CHF 125.– 40.001.138.00



**Reinigungsset Easy Care**  
**Kit di pulizia Easy Care**  
CHF 29.–/N 40.001.509.00

Zeichnung als pdf/ dxf und Montageanleitung siehe:  
V. disegno in formato pdf/ dxf e montaggio:  
suter.ch

**i Beschichtete Ventilbestandteile:**  
**im Preis und Lieferumfang inbegriffen**  
Siebstopfen: Überlaufblende und Überlaufklappe,  
Ventilkelch und Sieb  
Raumspär: Überlaufblende und Überlaufklappe,  
Ventilkelch und Sieb, Zugknopf Prime in Kunststoff  
(schwarz matt)

**Componenti piletta rivestiti: inclusi nel prezzo e nel  
corredo di fornitura**  
Tappi con griglietta: mascherina di troppopieno e tappo di  
troppopieno, tazza e griglietta  
Salvaspazio: mascherina di troppopieno e tappo di troppopieno,  
tazza e griglietta, pomolo Prime in plastica (nero  
opaco)

**!** Varianten: Der Austausch von Zugknöpfen erfolgt mittels Variantencode. Mehr Infos siehe Seite 395.  
Varianti: La sostituzione di pomoli avviene mediante codice variante. Per maggiori informazioni, vedere pag. 395.

Preis CHF/Prezzo in CHF

Modell Modello	Material Materiale	Ventil Piletta	Artikel-Nr. N. di articolo	Beckentiefe Profondità	Exkl. MWST IVA esclusa	Inkl. MWST IVA inclusa
<b>Brooklyn BYKAB N 100L U Black Edition</b>	Cristalite Plus, Nero	3 1/2" Raumspär Salvaspazio	10.105.324.00 <b>L</b>	200 mm	B 978.–	1057.–
		3 1/2" Siebstopfen A tappo con griglietta	10.105.325.00 <b>L</b>	200 mm	B 937.–	1013.–

## Carbon: CAR N 100U

SCHOCK

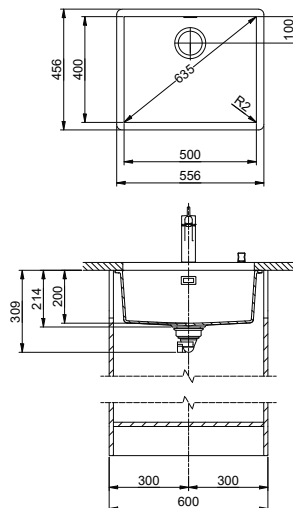

## Optionales Zubehör/Accessori opzionali

312



**Resteschale** gelocht  
**Vaschetta** forato  
CHF 106.– 40.000.912.00



**Resteschale** ungelocht  
**Vaschetta** non forato  
CHF 106.– 40.001.289.00



**Schneidebrett** aus Glas  
**Tagliere** in vetro  
CHF 151.– 40.000.909.00



**Schneidebrett** aus Kunststoff  
**Tagliere** sintetico  
CHF 151.– 40.001.277.00

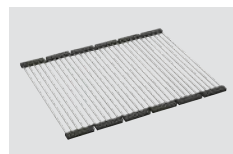

**Inox Pad**  
CHF 125.– 40.001.138.00



**Reinigungsset Easy Care**  
**Kit di pulizia Easy Care**  
CHF 29.–/N 40.001.509.00

Zeichnung als pdf / dxf und Montageanleitung siehe:  
V. disegno in formato pdf / dxf e montaggio:  
suter.ch

**!** Varianten: Der Austausch von Zugknöpfen erfolgt mittels Variantencode. Mehr Infos siehe Seite 395.  
Varianti: La sostituzione di pomoli avviene mediante codice variante. Per maggiori informazioni, vedere pag. 395.

Preis CHF/Prezzo in CHF

Modell Modello	Material Materiale	Ventil Piletta	Artikel-Nr. N. di articolo	Beckentiefe Profondità	Exkl. MWST IVA esclusa	Inkl. MWST IVA inclusa
<b>Carbon CAR N 100U</b>	Carbon Carbonio 	3 1/2" Raumspar Salvaspazio	10.104.142.00	200 mm	F 2360.–	2551.–





**Sortiment nach Unterschrankmassen**Assortimento per dimensioni di base **212****Edelstahl / Acciaio inox****Linero**

LIO 18F/7	<b>214–215</b>
LIO 34F/7	<b>216–217</b>
LIO 40F/7	<b>218–219</b>
LIO 45F/7	<b>220–221</b>
LIO 50F/7	<b>222–223</b>
LIO 55F/7	<b>224–225</b>

**Daneo**

DAN 34F/7	<b>226–227</b>
DAN 34IF/12	<b>228–229</b>
DAN 40F/7	<b>230–231</b>
DAN 40IF/12	<b>232–233</b>
DAN 45F/7	<b>234–235</b>
DAN 45IF/12	<b>236–237</b>
DAN 50F/7	<b>238–239</b>
DAN 50IF/12	<b>240–241</b>
DAN 55F/7	<b>242–243</b>
DAN 55IF/12	<b>244–245</b>
DAN 100-50IF	<b>246</b>
DAN 100-55IF	<b>247</b>
DAN 110-50IF	<b>248</b>
DAN 40IF/A	<b>249</b>
DAN 50IF/A	<b>250</b>
DAN 55IF/A	<b>251</b>
DAN 100-50IF/A	<b>252</b>
DAN 100-55IF/A	<b>253</b>
DAN 110-50IF/A	<b>254</b>

**Vantis**

V 34IF/12	<b>256–257</b>
V 40IF/12	<b>258–259</b>
V 45IF/12	<b>260–261</b>
V 50-42IF/12	<b>262–263</b>
V 50-35IF/12	<b>264–265</b>
V 55IF/12	<b>266–267</b>
VG 45IF/12 Green	<b>268</b>
VG 50-42IF/12 Green	<b>269</b>
VG 50-35IF/12 Green	<b>270</b>
VG 55IF/12 Green	<b>271</b>
VX 34IF/15 Varix	<b>272</b>
VX 40IF/15 Varix	<b>273</b>
VX 45IF/15 Varix	<b>274</b>
VX 50-42IF/15 Varix	<b>275</b>
VX 55IF/15 Varix	<b>276</b>

**Silver Star**

SIL 45IF/12	<b>277</b>
SIS 50IF/12	<b>278</b>
SIL 55IF/12	<b>279</b>

**Accento**

A 65IF/12	<b>280</b>
-----------	------------

**Granit (Cristadur)**

Granito (Cristadur)

**Linero**

LIO CD 50F/17	<b>282–285</b>
LIO CDAB 50F/17 Black Edition	<b>286–287</b>

**Granit (Cristalite Plus)**

Granito (Cristalite Plus)

**Daneo**

DAN CP 45F/17	<b>288</b>
DAN CP 50F/17	<b>290</b>
DAN CP 55F/17	<b>292</b>

**Montagematerial / Materiale per il montaggio**

Befestigungsklammern  
für Flächenbündige- und Flachrand-Becken  
Staffe di fissaggio  
per lavelli a filo top e lavelli sopra piano  
40.002.041.00



Befestigungsklammern  
für Flächenbündige- und Flachrand-Spülen  
Staffe di fissaggio  
per lavelli a filo top e lavelli sopra piano  
40.001.009.00

Sortiment nach Unterschrankmassen / Assortimento per dimensioni di base

35cm

40cm

45cm

50cm

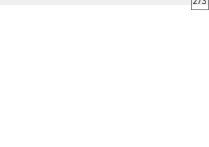
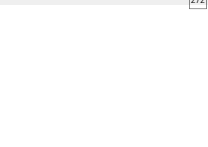
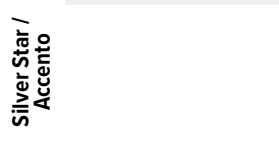
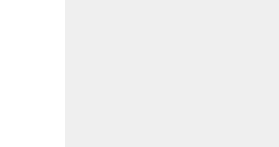
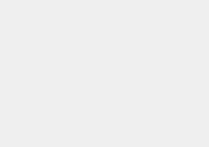
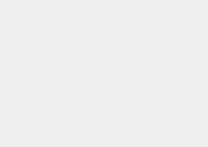
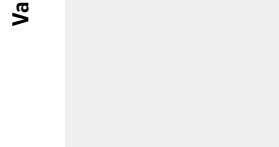
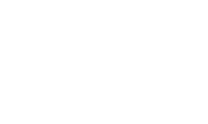
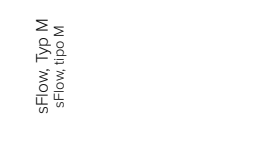
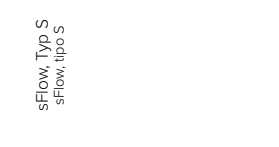

IF-Spülen  
IF-Lavelli

**GREEN LINE** Green Line ist eine eigenständige auf Nachhaltigkeit ausgerichtete Produktausführung.  
Green Line è una versione di prodotto autonoma calibrata sulla sostenibilità.



Auffrisch- und Pflegeservice  
Mehr Infos siehe Seite 25  
Servizio di pulizia e manutenzione  
Per maggiori informazioni, vedere pag. 25

**55cm**



Linero: LIO 50F/7\* 





Linero: LIO CD 50F/17\*   
Linero: LIO CDAB 50F/17\* 





Linero: LIO 50F/7\* 



Linero: LIO CD 50F/17\*   
Linero: LIO CDAB 50F/17\* 





Daneo: DAN 50F/7\*   
Daneo: DAN 50IF/12 



Daneo: DAN 50IF/A 



Daneo: DAN 50F/7\*   
Daneo: DAN 50IF/12 



Daneo: DAN 100-50IF 



Daneo: DAN 100-50IF/A 



Daneo: DAN 110-50IF 



Daneo: DAN 110-50IF/A 



Daneo: DAN CP 50F/17\* 



Vantis: V 50-42IF/12 



Vantis: V 50-35IF/12 



Vantis: V 50-42IF/12 



Vantis: V 50-35IF/12 



Vantis: VG 50-42IF/12 Green 



Vantis: VG 50-35IF/12 Green 



Vantis: VX 50-42IF/15 Varix 



Silver Star: SIS 50IF/12 

**60cm**





Linero: LIO 55F/7\* 



Linero: LIO 55F/7\* 



Daneo: DAN 55F/7\*   
Daneo: DAN 55IF/12 



Daneo: DAN 55IF/A 



Daneo: DAN 55F/7\*   
Daneo: DAN 55IF/12 



Daneo: DAN 100-55IF 



Daneo: DAN 100-55IF/A 



Daneo: DAN CP 55F/17\* 



Vantis: V 55IF/12 



Vantis: V 55IF/12 



Vantis: VG 55IF/12 Green 



Vantis: VX 55IF/15 Varix 



Silver Star: SIL 55IF/12 

**80cm**



Accento: A 65IF/12 

\*Nur für flächenbündigen Einbau erhältlich / \*Disponibili solo per montaggio a filo top

## Linero: LIO 18F/7

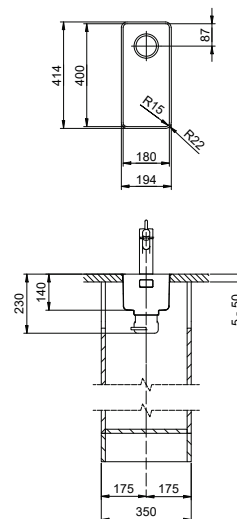
Randbreite 7 mm  
Larghezza bordo 7 mm

 Schwenkbare Überlaufkappe  
Placchetta di troppieno a ribalta

15

 Obenliegendes Sieb  
Griglietta superiore

14



## Optionales Zubehör/Accessori opzionali

312

**Resteschale gelocht**  
**Vaschetta forato**

CHF 106.– 40.000.912.00

**Resteschale ungelocht**  
**Vaschetta non forato**

CHF 106.– 40.001.289.00

**Schneidebrett aus Kunststoff**  
**Tagliere sintetico**

CHF 151.– 40.001.277.00

**Inox Pad**

CHF 125.– 40.001.138.00

Zeichnung als pdf / dxf und Montageanleitung siehe:  
V. disegno in formato pdf / dxf e montaggio:  
suter.ch



**Nur für flächenbündigen Einbau erhältlich.**  
Disponibile solo per montaggio a filo top.

**Flächenbündiger Einbau: Empfehlung zur Wahl der Arbeitsplatte**

Wir empfehlen den Einbau in Arbeitsplatten aus Keramik, Granit, Kunststein (z.B. Corian oder Varicor) oder Massivholz. Vom Einbau in beschichtete Spanplatten raten wir ab.

**Montaggio a filo top: Consiglio per la scelta del piano di lavoro**

Consigliamo il montaggio nei piani di lavoro in ceramica, granito, pietra artificiale (per es. Corian o Varicor) oppure in legno massiccio. Sconsigliamo la posa in pannelli di truciolato rivestiti.

Preis CHF/Prezzo in CHF

Modell Modello	Material Materiale	Ventil sFlow, Typ M Piletta sFlow, tipo M	Artikel-Nr. N. di articolo	Beckentiefe Profondità	Exkl. MWST IVA esclusa	Inkl. MWST IVA inclusa
<b>Linero LIO 18F/7</b>	Edelstahl, matt Acciaio inox, opaco	18/10	3 1/2" Tipo 10.105.654.00	140 mm	A	987.– 1067.–

# Linero: LIO 18F/7

Randbreite 7 mm  
Larghezza bordo 7 mm

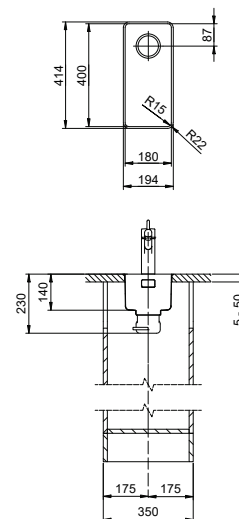

eFlow mit eControl  
eFlow con eControl

Schwenkbare Überlaufkappe  
Placchetta di troppopieno a ribalta

Desino: Verdeckter Ablauf mit untenliegendem Korb  
Desino: Scarico coperto con griglietta inferiore



Für eFlow Desino  
Per eFlow Desino



Für TouchFlow Desino und Tipo Desino  
Per TouchFlow Desino e Tipo Desino



Für eFlow Desino, TouchFlow Desino und Tipo Desino  
Per eFlow Desino, TouchFlow Desino e Tipo Desino



## Optionales Zubehör / Accessori opzionali

312



**Resteschale** gelocht  
**Vaschetta** forato  
CHF 106.– 40.000.912.00



**Resteschale** ungelocht  
**Vaschetta** non forato  
CHF 106.– 40.001.289.00



**Schneidebrett** aus Kunststoff  
**Tagliere** sintetico  
CHF 151.– 40.001.277.00

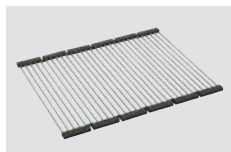

**Inox Pad**  
CHF 125.– 40.001.138.00

Zeichnung als pdf / dxf und Montageanleitung siehe:  
V. disegno in formato pdf / dxf e montaggio:  
suter.ch

**Nur für flächenbündigen Einbau erhältlich.**  
Disponibile solo per montaggio a filo top.

### Flächenbündiger Einbau: Empfehlung zur Wahl der Arbeitsplatte

Wir empfehlen den Einbau in Arbeitsplatten aus Keramik, Granit, Kunststein (z.B. Corian oder Varicor) oder Massivholz. Vom Einbau in beschichtete Spanplatten raten wir ab.

### Montaggio a filo top: Consiglio per la scelta del piano di lavoro

Consigliamo il montaggio nei piani di lavoro in ceramica, granito, pietra artificiale (per es. Corian o Varicor) oppure in legno massiccio. Sconsigliamo la posa in pannelli di truciolato rivestiti.

## Preis CHF/Prezzo in CHF

Modell Modello	Material Materiale	Ventil sFlow, Typ M Piletta sFlow, tipo M	Artikel-Nr. N. di articolo	Beckentiefe Profondità	Exkl. MWST IVA esclusa	Inkl. MWST IVA inclusa	VRG TRA	
Linero LIO 18F/7	Edelstahl, matt Acciaio inox, opaco	3 1/2" eFlow Desino	10.105.233.00	140 mm	A	1493.–	1614.–	0.19
		3 1/2" TouchFlow Desino	10.105.234.00	140 mm	A	1378.–	1490.–	0.19
		3 1/2" Tipo Desino	10.105.652.00	140 mm	A	1168.–	1263.–	

## Linero: LIO 34F/7

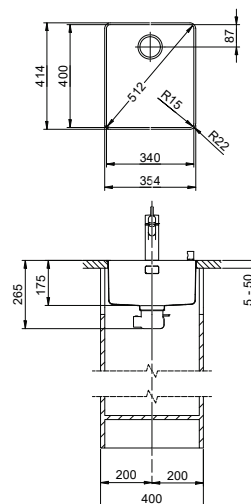
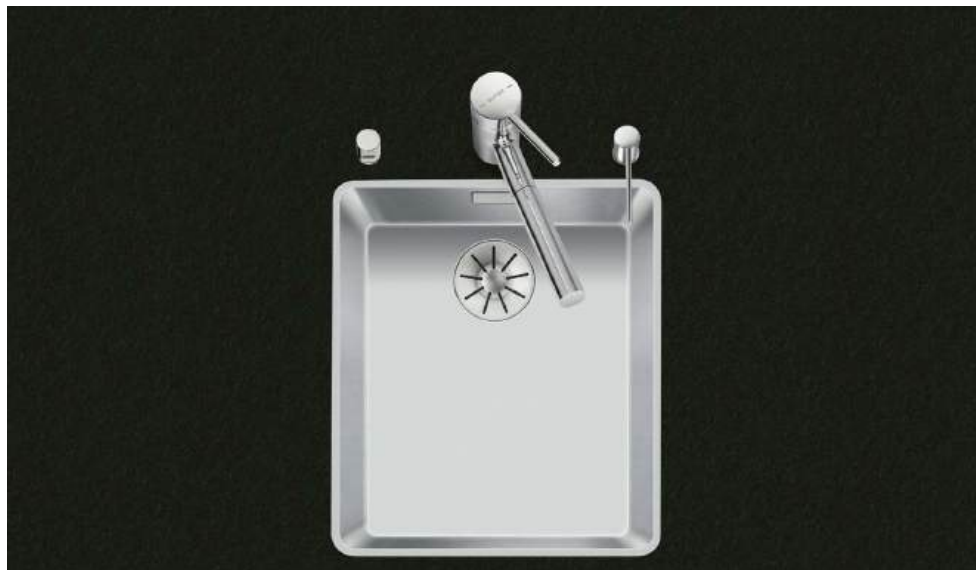
Randbreite 7 mm  
Larghezza bordo 7 mm

 Schwenkbare Überlaufkappe  
Placchetta di troppopieno a ribalta

 Obenliegendes Sieb  
Griglietta superiore

14



## Optionales Zubehör/Accessori opzionali

312

**Resteschale gelocht**  
**Vaschetta forato**  
CHF 106.– 40.000.912.00

**Resteschale ungelocht**  
**Vaschetta non forato**  
CHF 106.– 40.001.289.00

**Schneidebrett aus Glas**  
**Tagliere in vetro**  
CHF 151.– 40.000.909.00

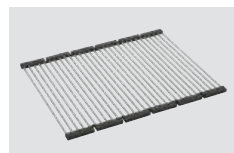
**Schneidebrett aus Kunststoff**  
**Tagliere sintetico**  
CHF 151.– 40.001.277.00

**Innox Pad**  
CHF 125.– 40.001.138.00

 Zeichnung als pdf/dxf und Montageanleitung siehe:  
V. disegno in formato pdf/dxf e montaggio:  
suter.ch

**Nur für flächenbündigen Einbau erhältlich.**  
Disponibile solo per montaggio a filo top.

**Flächenbündiger Einbau: Empfehlung zur Wahl der Arbeitsplatte**

Wir empfehlen den Einbau in Arbeitsplatten aus Keramik, Granit, Kunststein (z.B. Corian oder Varicor) oder Massivholz. Vom Einbau in beschichtete Spanplatten raten wir ab.

**Montaggio a filo top: Consiglio per la scelta del piano di lavoro**

Consigliamo il montaggio nei piani di lavoro in ceramica, granito, pietra artificiale (per es. Corian o Varicor) oppure in legno massiccio. Sconsigliamo la posa in pannelli di truciolato rivestiti.

 Varianten: Der Austausch von Zugknöpfen erfolgt mittels Variantencode. Mehr Infos siehe Seite 395.  
Varianti: La sostituzione di pomoli avviene mediante codice variante. Per maggiori informazioni, vedere pag. 395.

## Preis CHF/Prezzo in CHF

Modell Modello	Material Materiale	Ventil sFlow, Typ M Piletta sFlow, tipo M	Artikel-Nr. N. di articolo	Beckentiefe Profondità	Exkl. MWST IVA esclusa	Inkl. MWST IVA inclusa	VRG TRA		
Linero LIO 34F/7	Edelstahl, matt Acciaio inox, opaco	18/10	3 1/2" TouchFlow	10.105.656.00	175 mm	A	1556.–	1682.–	0.19
			3 1/2" Druckknopf Pulsante	10.106.241.00	175 mm	A	1403.–	1517.–	
			3 1/2" Raumspar Salvaspazio	10.105.657.00	175 mm	A	1358.–	1468.–	
			3 1/2" Tipo	10.105.658.00	175 mm	A	1317.–	1424.–	

# Linero: LIO 34F/7

Randbreite 7 mm  
Larghezza bordo 7 mm

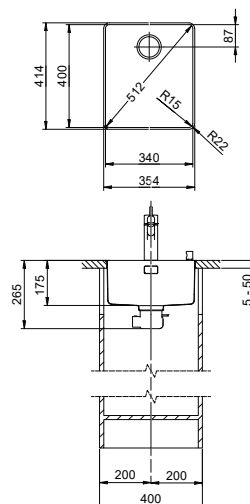

eFlow mit eControl  
eFlow con eControl

Schwenkbare Überlaufkappe  
Placchetta di troppopieno a ribalta

Desino: Verdeckter Ablauf mit untenliegendem Korb  
Desino: Scarico coperto con griglietta inferiore



Für eFlow Desino  
Per eFlow Desino

Für TouchFlow Desino, Raumspar Desino und Tipo Desino  
Per TouchFlow Desino, Salvaspazio Desino e Tipo Desino

Für eFlow Desino, TouchFlow Desino, Raumspar Desino und Tipo Desino  
Per eFlow Desino, TouchFlow Desino, Salvaspazio Desino e Tipo Desino

## Optionales Zubehör/Accessori opzionali

312



**Resteschale gelocht**  
**Vaschetta forata**  
CHF 106.– 40.000.912.00



**Resteschale ungelocht**  
**Vaschetta non forata**  
CHF 106.– 40.001.289.00



**Schneidebrett aus Glas**  
**Tagliere in vetro**  
CHF 151.– 40.000.909.00



**Schneidebrett aus Kunststoff**  
**Tagliere sintetico**  
CHF 151.– 40.001.277.00

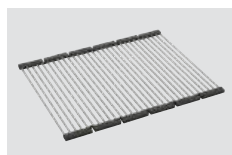

**Inox Pad**  
CHF 125.– 40.001.138.00

Zeichnung als pdf/dxf und Montageanleitung siehe:  
V. disegno in formato pdf/dxf e montaggio:  
suter.ch

**Nur für flächenbündigen Einbau erhältlich.**  
Disponibile solo per montaggio a filo top.

### Flächenbündiger Einbau: Empfehlung zur Wahl der Arbeitsplatte

Wir empfehlen den Einbau in Arbeitsplatten aus Keramik, Granit, Kunststein (z.B. Corian oder Varicor) oder Massivholz. Vom Einbau in beschichtete Spanplatten raten wir ab.

### Montaggio a filo top: Consiglio per la scelta del piano di lavoro

Consigliamo il montaggio nei piani di lavoro in ceramica, granito, pietra artificiale (per es. Corian o Varicor) oppure in legno massiccio. Sconsigliamo la posa in pannelli di truciolato rivestiti.

Varianten: Der Austausch von Zugknöpfen erfolgt mittels Variantencode. Mehr Infos siehe Seite 395.  
Varianti: La sostituzione di pomoli avviene mediante codice variante. Per maggiori informazioni, vedere pag. 395.

## Preis CHF/Prezzo in CHF

Modell Modello	Material Materiale	Ventil sFlow, Typ M Piletta sFlow, tipo M	Artikel-Nr. N. di articolo	Beckentiefe Profondità	Exkl. MWST IVA esclusa	Inkl. MWST IVA inclusa	VRG TRA	
<b>Linero LIO 34F/7</b>	Edelstahl, matt Acciaio inox, opaco	18/10	3 1/2" eFlow Desino	10.105.235.00	175 mm	A 1823.–	1971.–	0.19
			3 1/2" TouchFlow Desino	10.105.236.00	175 mm	A 1708.–	1846.–	0.19
			3 1/2" Raumspar Desino Salvaspazio Desino	10.105.237.00	175 mm	A 1498.–	1619.–	
			3 1/2" Tipo Desino	10.105.655.00	175 mm	A 1498.–	1619.–	

## Linero: LIO 40F/7

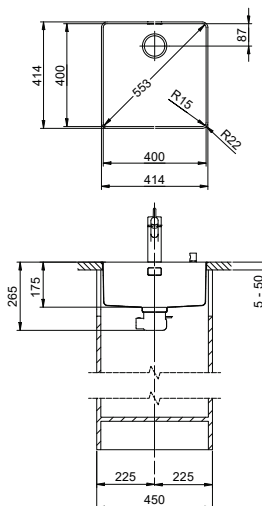
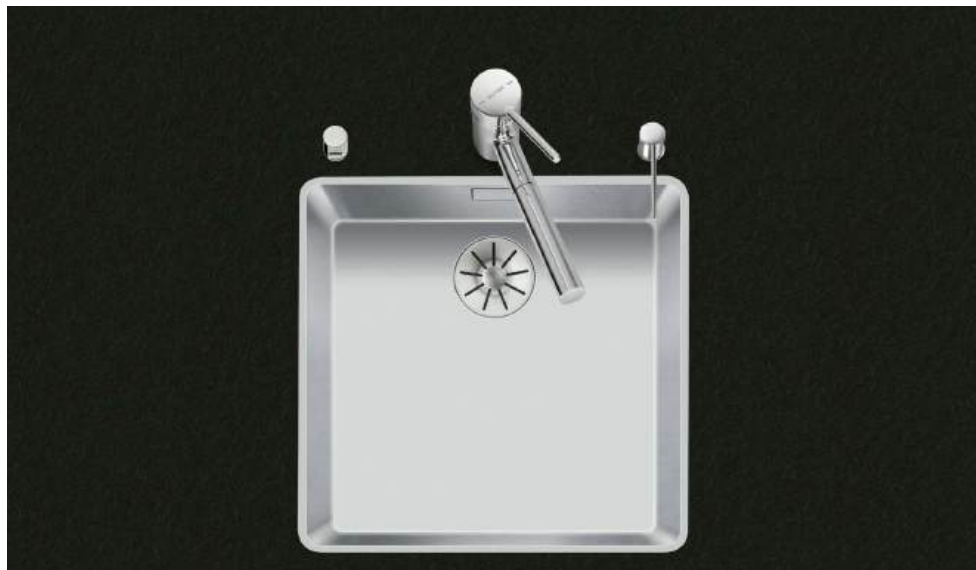
Randbreite 7 mm  
Larghezza bordo 7 mm

 Schwenkbare Überlaufkappe  
Placchetta di troppopieno a ribalta

15

 Obenliegendes Sieb  
Griglietta superiore

14



## Optionales Zubehör/Accessori opzionali

312

**Resteschale gelocht**  
**Vaschetta forato**  
CHF 106.– 40.000.912.00

**Resteschale ungelocht**  
**Vaschetta non forato**  
CHF 106.– 40.001.289.00

**Schneidebrett aus Glas**  
**Tagliere in vetro**  
CHF 151.– 40.000.909.00

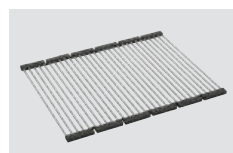
**Schneidebrett aus Kunststoff**  
**Tagliere sintetico**  
CHF 151.– 40.001.277.00

**Innox Pad**  
CHF 125.– 40.001.138.00

 Zeichnung als pdf/dxf und Montageanleitung siehe:  
V. disegno in formato pdf/dxf e montaggio:  
suter.ch

**Nur für flächenbündigen Einbau erhältlich.**  
Disponibile solo per montaggio a filo top.

**Flächenbündiger Einbau: Empfehlung zur Wahl der Arbeitsplatte**

Wir empfehlen den Einbau in Arbeitsplatten aus Keramik, Granit, Kunststein (z.B. Corian oder Varicor) oder Massivholz. Vom Einbau in beschichtete Spanplatten raten wir ab.

**Montaggio a filo top: Consiglio per la scelta del piano di lavoro**

Consigliamo il montaggio nei piani di lavoro in ceramica, granito, pietra artificiale (per es. Corian o Varicor) oppure in legno massiccio. Sconsigliamo la posa in pannelli di truciolato rivestiti.

 Varianten: Der Austausch von Zugknöpfen erfolgt mittels Variantencode. Mehr Infos siehe Seite 395.  
Varianti: La sostituzione di pomoli avviene mediante codice variante. Per maggiori informazioni, vedere pag.395.

## Preis CHF/Prezzo in CHF

Modell Modello	Material Materiale	Ventil sFlow, Typ M Piletta sFlow, tipo M	Artikel-Nr. N. di articolo	Beckentiefe Profondità	Exkl. MWST IVA esclusa	Inkl. MWST IVA inclusa	VRG TRA		
Linero LIO 40F/7	Edelstahl, matt Acciaio inox, opaco	18/10	3 1/2" TouchFlow	10.105.660.00	175 mm	A	1632.–	1764.–	0.19
			3 1/2" Druckknopf Pulsante	10.106.242.00	175 mm	A	1479.–	1599.–	
			3 1/2" Raumspar Salvaspazio	10.105.661.00	175 mm	A	1434.–	1550.–	
			3 1/2" Tipo	10.105.662.00	175 mm	A	1393.–	1506.–	

# Linero: LIO 40F/7

Randbreite 7 mm  
Larghezza bordo 7 mm

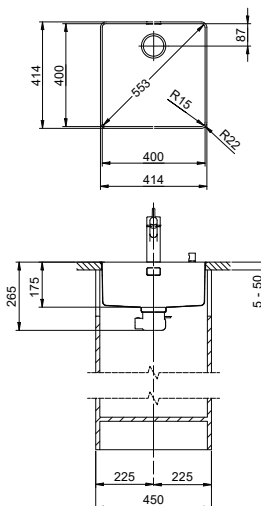

eFlow mit eControl  
eFlow con eControl

Schwenkbare Überlaufkappe  
Placchetta di troppopieno a ribalta

Desino: Verdeckter Ablauf mit untenliegendem Korb  
Desino: Scarico coperto con griglietta inferiore



Für eFlow Desino  
Per eFlow Desino

Für TouchFlow Desino, Raumspar Desino und Tipo Desino  
Per TouchFlow Desino, Salvaspazio Desino e Tipo Desino

Für eFlow Desino, TouchFlow Desino, Raumspar Desino und Tipo Desino  
Per eFlow Desino, TouchFlow Desino, Salvaspazio Desino e Tipo Desino

## Optionales Zubehör/Accessori opzionali

312



**Resteschale gelocht**  
**Vaschetta forata**  
CHF 106.– 40.000.912.00



**Resteschale ungelocht**  
**Vaschetta non forata**  
CHF 106.– 40.001.289.00



**Schneidebrett aus Glas**  
**Tagliere in vetro**  
CHF 151.– 40.000.909.00



**Schneidebrett aus Kunststoff**  
**Tagliere sintetico**  
CHF 151.– 40.001.277.00

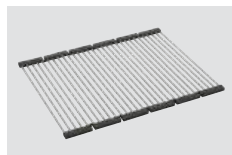

**Inox Pad**  
CHF 125.– 40.001.138.00

Zeichnung als pdf/dxf und Montageanleitung siehe:  
V. disegno in formato pdf/dxf e montaggio:  
suter.ch

**Nur für flächenbündigen Einbau erhältlich.**  
Disponibile solo per montaggio a filo top.

### Flächenbündiger Einbau: Empfehlung zur Wahl der Arbeitsplatte

Wir empfehlen den Einbau in Arbeitsplatten aus Keramik, Granit, Kunststein (z.B. Corian oder Varicor) oder Massivholz. Vom Einbau in beschichtete Spanplatten raten wir ab.

### Montaggio a filo top: Consiglio per la scelta del piano di lavoro

Consigliamo il montaggio nei piani di lavoro in ceramica, granito, pietra artificiale (per es. Corian o Varicor) oppure in legno massiccio. Sconsigliamo la posa in pannelli di truciolato rivestiti.

Varianten: Der Austausch von Zugknöpfen erfolgt mittels Variantencode. Mehr Infos siehe Seite 395.  
Varianti: La sostituzione di pomoli avviene mediante codice variante. Per maggiori informazioni, vedere pag. 395.

## Preis CHF/Prezzo in CHF

Modell Modello	Material Materiale	Ventil sFlow, Typ M Piletta sFlow, tipo M	Artikel-Nr. N. di articolo	Beckentiefe Profondità	Exkl. MWST IVA esclusa	Inkl. MWST IVA inclusa	VRG TRA	
<b>Linero LIO 40F/7</b>	Edelstahl, matt Acciaio inox, opaco	18/10	3 1/2" eFlow Desino	10.105.238.00	175 mm	A 1899.–	2053.–	0.19
			3 1/2" TouchFlow Desino	10.105.239.00	175 mm	A 1784.–	1929.–	0.19
			3 1/2" Raumspar Desino Salvaspazio Desino	10.105.240.00	175 mm	A 1574.–	1701.–	
			3 1/2" Tipo Desino	10.105.659.00	175 mm	A 1574.–	1701.–	

## Linero: LIO 45F/7

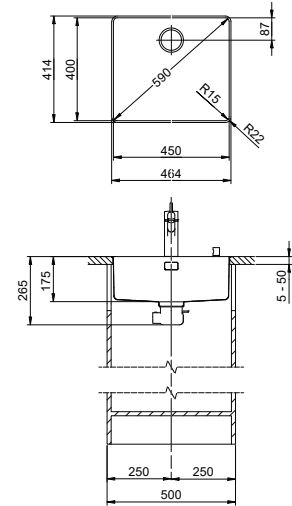
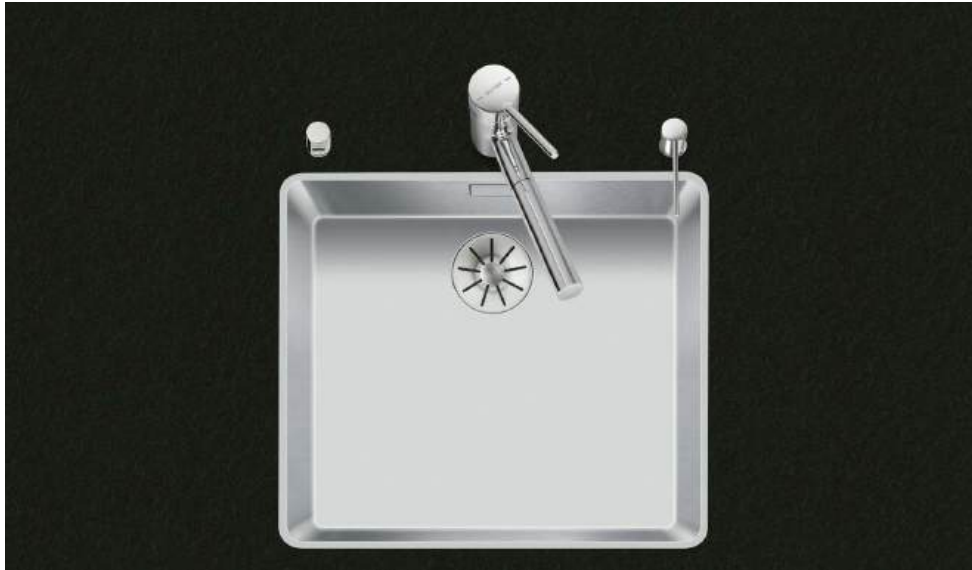
Randbreite 7 mm  
Larghezza bordo 7 mm
**Schwenkbare Überlaufkappe**  
Placchetta di troppopieno a ribalta

15

**Obenliegendes Sieb**  
Griglietta superiore

14



## Optionales Zubehör/Accessori opzionali

312

**Resteschale gelocht**  
**Vaschetta forato**  
CHF 106.– 40.000.912.00

**Resteschale ungelocht**  
**Vaschetta non forato**  
CHF 106.– 40.001.289.00

**Schneidebrett aus Glas**  
**Tagliere in vetro**  
CHF 151.– 40.000.909.00

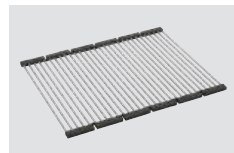
**Schneidebrett aus Kunststoff**  
**Tagliere sintetico**  
CHF 151.– 40.001.277.00

**Inox Pad**  
CHF 125.– 40.001.138.00

Zeichnung als pdf/dxf und Montageanleitung siehe:  
V. disegno in formato pdf/dxf e montaggio:  
suter.ch

**Nur für flächenbündigen Einbau erhältlich.**  
Disponibile solo per montaggio a filo top.

**Flächenbündiger Einbau: Empfehlung zur Wahl der Arbeitsplatte**

Wir empfehlen den Einbau in Arbeitsplatten aus Keramik, Granit, Kunststein (z.B. Corian oder Varicor) oder Massivholz. Vom Einbau in beschichtete Spanplatten raten wir ab.

**Montaggio a filo top: Consiglio per la scelta del piano di lavoro**

Consigliamo il montaggio nei piani di lavoro in ceramica, granito, pietra artificiale (per es. Corian o Varicor) oppure in legno massiccio. Sconsigliamo la posa in pannelli di truciolato rivestiti.

Varianten: Der Austausch von Zugknöpfen erfolgt mittels Variantencode. Mehr Infos siehe Seite 395.  
Varianti: La sostituzione di pomoli avviene mediante codice variante. Per maggiori informazioni, vedere pag. 395.

## Preis CHF/Prezzo in CHF

Modell Modello	Material Materiale	Ventil sFlow, Typ M Piletta sFlow, tipo M	Artikel-Nr. N. di articolo	Beckentiefe Profondità	Exkl. MWST IVA esclusa	Inkl. MWST IVA inclusa	VRG TRA	
Linero LIO 45F/7	Edelstahl, matt Acciaio inox, opaco	18/10	3 1/2" TouchFlow	10.105.664.00	175 mm	A 1663.–	1798.–	0.19
			3 1/2" Druckknopf Pulsante	10.106.243.00	175 mm	A 1510.–	1632.–	
			3 1/2" Raumspar Salvaspazio	10.105.665.00	175 mm	A 1465.–	1584.–	
			3 1/2" Tipo	10.105.666.00	175 mm	A 1424.–	1539.–	

# Linero: LIO 45F/7

Randbreite 7 mm  
Larghezza bordo 7 mm

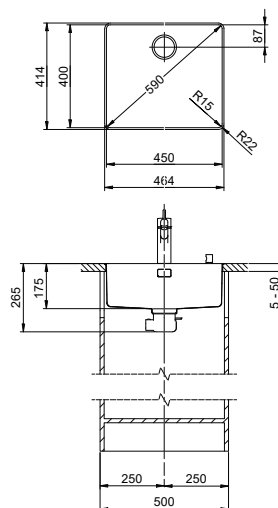

eFlow mit eControl  
eFlow con eControl

Schwenkbare Überlaufkappe  
Placchetta di troppopieno a ribalta

Desino: Verdeckter Ablauf mit untenliegendem Korb  
Desino: Scarico coperto con griglietta inferiore



Für eFlow Desino  
Per eFlow Desino

Für TouchFlow Desino, Raumspaar Desino und Typo Desino  
Per TouchFlow Desino, Salvaspazio Desino e Typo Desino



Für eFlow Desino, TouchFlow Desino, Raumspaar Desino und Typo Desino  
Per eFlow Desino, TouchFlow Desino, Salvaspazio Desino e Typo Desino

## Optionales Zubehör/Accessori opzionali



**Resteschale gelocht**  
**Vaschetta forata**  
CHF 106.– 40.000.912.00



**Resteschale ungelocht**  
**Vaschetta non forata**  
CHF 106.– 40.001.289.00



**Schneidebrett aus Glas**  
**Tagliere in vetro**  
CHF 151.– 40.000.909.00



**Schneidebrett aus Kunststoff**  
**Tagliere sintetico**  
CHF 151.– 40.001.277.00

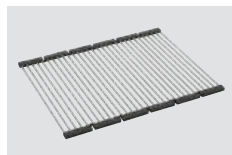

**Inox Pad**  
CHF 125.– 40.001.138.00

**Nur für flächenbündigen Einbau erhältlich.**  
Disponibile solo per montaggio a filo top.

### Flächenbündiger Einbau: Empfehlung zur Wahl der Arbeitsplatte

Wir empfehlen den Einbau in Arbeitsplatten aus Keramik, Granit, Kunststein (z.B. Corian oder Varicor) oder Massivholz. Vom Einbau in beschichtete Spanplatten raten wir ab.

### Montaggio a filo top: Consiglio per la scelta del piano di lavoro

Consigliamo il montaggio nei piani di lavoro in ceramica, granito, pietra artificiale (per es. Corian o Varicor) oppure in legno massiccio. Sconsigliamo la posa in pannelli di truciolato rivestiti.

Varianten: Der Austausch von Zugknöpfen erfolgt mittels Variantencode. Mehr Infos siehe Seite 395.  
Varianti: La sostituzione di pomoli avviene mediante codice variante. Per maggiori informazioni, vedere pag. 395.

## Preis CHF/Prezzo in CHF

Modell Modello	Material Materiale	Ventil sFlow, Typ M Piletta sFlow, tipo M	Artikel-Nr. N. di articolo	Beckentiefe Profondità	Exkl. MWST IVA esclusa	Inkl. MWST IVA inclusa	VRG TRA		
<b>Linero LIO 45F/7</b>	Edelstahl, matt Acciaio inox, opaco	18/10	3 1/2" eFlow Desino	10.105.241.00	175 mm	A	1930.–	2086.–	0.19
			3 1/2" TouchFlow Desino	10.105.242.00	175 mm	A	1815.–	1962.–	0.19
			3 1/2" Raumspaar Desino Salvaspazio Desino	10.105.243.00	175 mm	A	1605.–	1735.–	
			3 1/2" Typo Desino	10.105.663.00	175 mm	A	1605.–	1735.–	

## Linero: LIO 50F/7

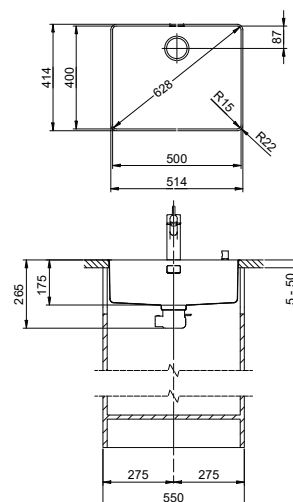
Randbreite 7 mm  
Larghezza bordo 7 mm

 Schwenkbare Überlaufkappe  
Placchetta di troppopieno a ribalta

15

 Obenliegendes Sieb  
Griglietta superiore

14



## Optionales Zubehör/Accessori opzionali

312

**Resteschale gelocht**  
**Vaschetta forato**  
CHF 106.– 40.000.912.00

**Resteschale ungelocht**  
**Vaschetta non forato**  
CHF 106.– 40.001.289.00

**Schneidebrett aus Glas**  
**Tagliere in vetro**  
CHF 151.– 40.000.909.00

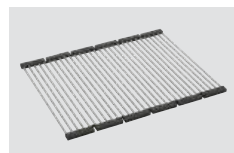
**Schneidebrett aus Kunststoff**  
**Tagliere sintetico**  
CHF 151.– 40.001.277.00

**Inox Pad**  
CHF 125.– 40.001.138.00

 Zeichnung als pdf/dxf und Montageanleitung siehe:  
V. disegno in formato pdf/dxf e montaggio:  
suter.ch

**Nur für flächenbündigen Einbau erhältlich.**  
Disponibile solo per montaggio a filo top.

**Flächenbündiger Einbau: Empfehlung zur Wahl der Arbeitsplatte**

Wir empfehlen den Einbau in Arbeitsplatten aus Keramik, Granit, Kunststein (z.B. Corian oder Varicor) oder Massivholz. Vom Einbau in beschichtete Spanplatten raten wir ab.

**Montaggio a filo top: Consiglio per la scelta del piano di lavoro**

Consigliamo il montaggio nei piani di lavoro in ceramica, granito, pietra artificiale (per es. Corian o Varicor) oppure in legno massiccio. Sconsigliamo la posa in pannelli di truciolato rivestiti.

 Varianten: Der Austausch von Zugknöpfen erfolgt mittels Variantencode. Mehr Infos siehe Seite 395.  
Varianti: La sostituzione di pomoli avviene mediante codice variante. Per maggiori informazioni, vedere pag.395.

## Preis CHF/Prezzo in CHF

Modell Modello	Material Materiale	Ventil sFlow, Typ M Piletta sFlow, tipo M	Artikel-Nr. N. di articolo	Beckentiefe Profondità	Exkl. MWST IVA esclusa	Inkl. MWST IVA inclusa	VRG TRA		
Linero LIO 50F/7	Edelstahl, matt Acciaio inox, opaco	18/10	3 1/2" TouchFlow	10.105.668.00	175 mm	A	1691.–	1828.–	0.19
			3 1/2" Druckknopf Pulsante	10.106.244.00	175 mm	A	1538.–	1663.–	
			3 1/2" Raumspar Salvaspazio	10.105.669.00	175 mm	A	1493.–	1614.–	
			3 1/2" Tipo	10.105.670.00	175 mm	A	1452.–	1570.–	

# Linero: LIO 50F/7

Randbreite 7 mm  
Larghezza bordo 7 mm

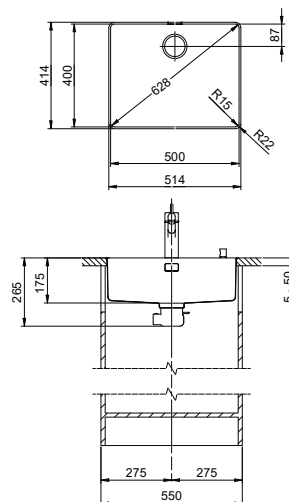

eFlow mit eControl  
eFlow con eControl

Schwenkbare Überlaufkappe  
Placchetta di troppopieno a ribalta

Desino: Verdeckter Ablauf mit untenliegendem Korb  
Desino: Scarico coperto con griglietta inferiore



Für eFlow Desino  
Per eFlow Desino

Für TouchFlow Desino, Raumspaar Desino und Typo Desino  
Per TouchFlow Desino, Salvaspazio Desino e Typo Desino



Für eFlow Desino, TouchFlow Desino, Raumspaar Desino und Typo Desino  
Per eFlow Desino, TouchFlow Desino, Salvaspazio Desino e Typo Desino

## Optionales Zubehör/Accessori opzionali

312



**Resteschale gelocht**  
**Vaschetta forata**  
CHF 106.– 40.000.912.00



**Resteschale ungelocht**  
**Vaschetta non forata**  
CHF 106.– 40.001.289.00



**Schneidebrett aus Glas**  
**Tagliere in vetro**  
CHF 151.– 40.000.909.00



**Schneidebrett aus Kunststoff**  
**Tagliere sintetico**  
CHF 151.– 40.001.277.00

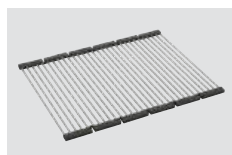

**Inox Pad**  
CHF 125.– 40.001.138.00

Zeichnung als pdf/ dxf und Montageanleitung siehe:  
V. disegno in formato pdf/ dxf e montaggio:  
suter.ch

**Nur für flächenbündigen Einbau erhältlich.**  
Disponibile solo per montaggio a filo top.

### Flächenbündiger Einbau: Empfehlung zur Wahl der Arbeitsplatte

Wir empfehlen den Einbau in Arbeitsplatten aus Keramik, Granit, Kunststein (z.B. Corian oder Varicor) oder Massivholz. Vom Einbau in beschichtete Spanplatten raten wir ab.

### Montaggio a filo top: Consiglio per la scelta del piano di lavoro

Consigliamo il montaggio nei piani di lavoro in ceramica, granito, pietra artificiale (per es. Corian o Varicor) oppure in legno massiccio. Sconsigliamo la posa in pannelli di truciolato rivestiti.

Varianten: Der Austausch von Zugknöpfen erfolgt mittels Variantencode. Mehr Infos siehe Seite 395.  
Varianti: La sostituzione di pomoli avviene mediante codice variante. Per maggiori informazioni, vedere pag. 395.

## Preis CHF/Prezzo in CHF

Modell Modello	Material Materiale	Ventil sFlow, Typ M Piletta sFlow, tipo M	Artikel-Nr. N. di articolo	Beckentiefe Profondità	Exkl. MWST IVA esclusa	Inkl. MWST IVA inclusa	VRG TRA		
<b>Linero LIO 50F/7</b>	Edelstahl, matt Acciaio inox, opaco	18/10	3 1/2" eFlow Desino	10.105.244.00	175 mm	A	1958.–	2117.–	0.19
			3 1/2" TouchFlow Desino	10.105.245.00	175 mm	A	1843.–	1992.–	0.19
			3 1/2" Raumspaar Desino Salvaspazio Desino	10.105.246.00	175 mm	A	1633.–	1765.–	
			3 1/2" Typo Desino	10.105.667.00	175 mm	A	1633.–	1765.–	

## Linero: LIO 55F/7

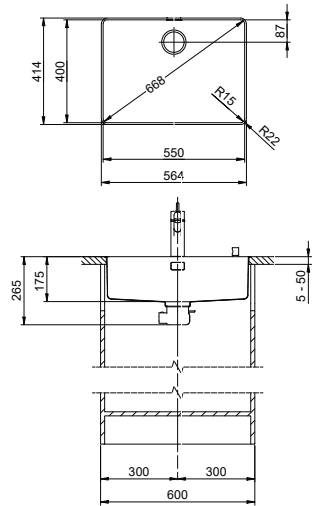
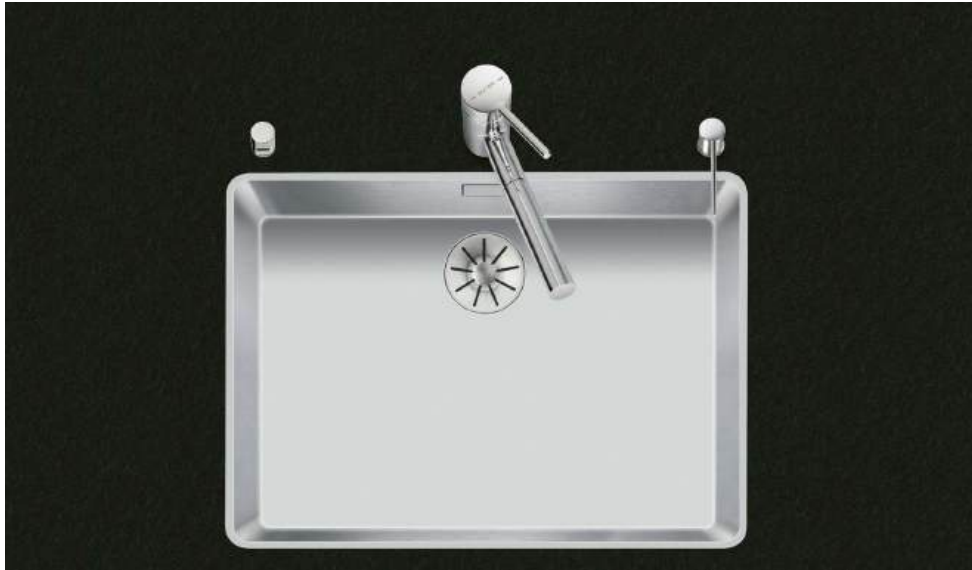
Randbreite 7 mm  
Larghezza bordo 7 mm

 Schwenkbare Überlaufkappe  
Placchetta di troppopieno a ribalta

15

 Obenliegendes Sieb  
Griglietta superiore

14



## Optionales Zubehör/Accessori opzionali

312

**Resteschale gelocht**  
**Vaschetta forato**  
CHF 106.– 40.000.912.00

**Resteschale ungelocht**  
**Vaschetta non forato**  
CHF 106.– 40.001.289.00

**Schneidebrett aus Glas**  
**Tagliere in vetro**  
CHF 151.– 40.000.909.00

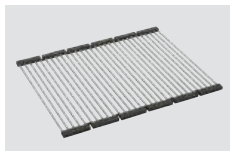
**Schneidebrett aus Kunststoff**  
**Tagliere sintetico**  
CHF 151.– 40.001.277.00

**Inox Pad**  
CHF 125.– 40.001.138.00

 Zeichnung als pdf/dxf und Montageanleitung siehe:  
V. disegno in formato pdf/dxf e montaggio:  
suter.ch

**Nur für flächenbündigen Einbau erhältlich.**  
Disponibile solo per montaggio a filo top.

**Flächenbündiger Einbau: Empfehlung zur Wahl der Arbeitsplatte**

Wir empfehlen den Einbau in Arbeitsplatten aus Keramik, Granit, Kunststein (z.B. Corian oder Varicor) oder Massivholz. Vom Einbau in beschichtete Spanplatten raten wir ab.

**Montaggio a filo top: Consiglio per la scelta del piano di lavoro**

Consigliamo il montaggio nei piani di lavoro in ceramica, granito, pietra artificiale (per es. Corian o Varicor) oppure in legno massiccio. Sconsigliamo la posa in pannelli di truciolato rivestiti.

 Varianten: Der Austausch von Zugknöpfen erfolgt mittels Variantencode. Mehr Infos siehe Seite 395.  
Varianti: La sostituzione di pomoli avviene mediante codice variante. Per maggiori informazioni, vedere pag. 395.

## Preis CHF/Prezzo in CHF

Modell Modello	Material Materiale	Ventil sFlow, Typ M Piletta sFlow, tipo M	Artikel-Nr. N. di articolo	Beckentiefe Profondità	Exkl. MWST IVA esclusa	Inkl. MWST IVA inclusa	VRG TRA	
Linero LIO 55F/7	Edelstahl, matt Acciaio inox, opaco	18/10	3 1/2" TouchFlow	10.105.672.00	175 mm	A 1797.–	1943.–	0.19
			3 1/2" Druckknopf Pulsante	10.106.245.00	175 mm	A 1644.–	1777.–	
			3 1/2" Raumspar Salvaspazio	10.105.673.00	175 mm	A 1599.–	1729.–	
			3 1/2" Tipo	10.105.674.00	175 mm	A 1558.–	1684.–	

# Linero: LIO 55F/7

Randbreite 7 mm  
Larghezza bordo 7 mm

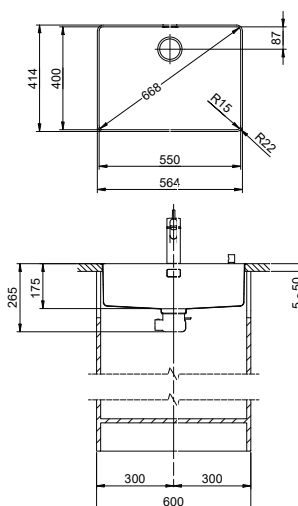

eFlow mit eControl  
eFlow con eControl

Schwenkbare Überlaufkappe  
Placchetta di troppopieno a ribalta

Desino: Verdeckter Ablauf mit untenliegendem Korb  
Desino: Scarico coperto con griglietta inferiore



Für eFlow Desino  
Per eFlow Desino

Für TouchFlow Desino, Raumspar Desino und Tipo Desino  
Per TouchFlow Desino, Salvaspazio Desino e Tipo Desino

Für eFlow Desino, TouchFlow Desino, Raumspar Desino und Tipo Desino  
Per eFlow Desino, TouchFlow Desino, Salvaspazio Desino e Tipo Desino

## Optionales Zubehör / Accessori opzionali

312



**Resteschale gelocht**  
Vaschetta forata  
CHF 106.– 40.000.912.00



**Resteschale ungelocht**  
Vaschetta non forata  
CHF 106.– 40.001.289.00



**Schneidebrett aus Glas**  
Tagliere in vetro  
CHF 151.– 40.000.909.00



**Schneidebrett aus Kunststoff**  
Tagliere sintetico  
CHF 151.– 40.001.277.00

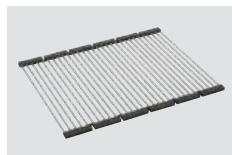

**Inox Pad**  
CHF 125.– 40.001.138.00

Zeichnung als pdf / dxf und Montageanleitung siehe:  
V. disegno in formato pdf / dxf e montaggio:  
suter.ch

**Nur für flächenbündigen Einbau erhältlich.**  
Disponibile solo per montaggio a filo top.

### Flächenbündiger Einbau: Empfehlung zur Wahl der Arbeitsplatte

Wir empfehlen den Einbau in Arbeitsplatten aus Keramik, Granit, Kunststein (z.B. Corian oder Varicor) oder Massivholz. Vom Einbau in beschichtete Spanplatten raten wir ab.

### Montaggio a filo top: Consiglio per la scelta del piano di lavoro

Consigliamo il montaggio nei piani di lavoro in ceramica, granito, pietra artificiale (per es. Corian o Varicor) oppure in legno massiccio. Sconsigliamo la posa in pannelli di truciolato rivestiti.

Varianten: Der Austausch von Zugknöpfen erfolgt mittels Variantencode. Mehr Infos siehe Seite 395.  
Varianti: La sostituzione di pomoli avviene mediante codice variante. Per maggiori informazioni, vedere pag. 395.

## Preis CHF/Prezzo in CHF

Modell Modello	Material Materiale	Ventil sFlow, Typ M Piletta sFlow, tipo M	Artikel-Nr. N. di articolo	Beckentiefe Profondità	Exkl. MWST IVA esclusa	Inkl. MWST IVA inclusa	VRG TRA		
<b>Linero LIO 55F/7</b>	Edelstahl, matt Acciaio inox, opaco	18/10	3 1/2" eFlow Desino	10.105.247.00	175 mm	A	2064.–	2231.–	0.19
			3 1/2" TouchFlow Desino	10.105.248.00	175 mm	A	1949.–	2107.–	0.19
			3 1/2" Raumspar Desino Salvaspazio Desino	10.105.249.00	175 mm	A	1739.–	1880.–	
			3 1/2" Tipo Desino	10.105.671.00	175 mm	A	1739.–	1880.–	

## Daneo: DAN 34F/7

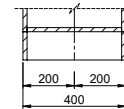
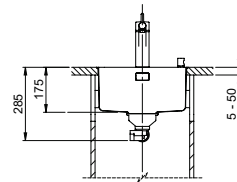
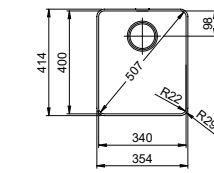
Randbreite 7 mm  
Larghezza bordo 7 mm

 Schwenkbare Überlaufkappe  
Placchetta di troppopieno a ribalta

15

 Obenliegendes Sieb  
Griglietta superiore

14



Zeichnung als pdf/dxf und Montageanleitung siehe:  
V. disegno in formato pdf/dxf e montaggio:  
suter.ch

## Optionales Zubehör/Accessori opzionali

312

**Resteschale gelocht**  
**Vaschetta forato**  
CHF 106.– 40.000.912.00

**Resteschale ungelocht**  
**Vaschetta non forato**  
CHF 106.– 40.001.289.00

**Schneidebrett aus Glas**  
**Tagliere in vetro**  
CHF 151.– 40.000.909.00

**Schneidebrett aus Kunststoff**  
**Tagliere sintetico**  
CHF 151.– 40.001.277.00



**Nur für flächenbündigen Einbau erhältlich.**  
Disponibile solo per montaggio a filo top.

**Flächenbündiger Einbau: Empfehlung zur Wahl der Arbeitsplatte**

Wir empfehlen den Einbau in Arbeitsplatten aus Keramik, Granit, Kunststein (z.B. Corian oder Varicor) oder Massivholz. Vom Einbau in beschichtete Spanplatten raten wir ab.

**Montaggio a filo top: Consiglio per la scelta del piano di lavoro**

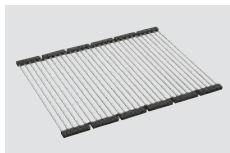
Consigliamo il montaggio nei piani di lavoro in ceramica, granito, pietra artificiale (per es. Corian o Varicor) oppure in legno massiccio. Sconsigliamo la posa in pannelli di truciolato rivestiti.

**Inox Pad**  
CHF 125.– 40.001.138.00



Varianten: Der Austausch von Zugknöpfen erfolgt mittels Variantencode. Mehr Infos siehe Seite 395.  
Varianti: La sostituzione di pomoli avviene mediante codice variante. Per maggiori informazioni, vedere pag. 395.

## Preis CHF/Prezzo in CHF

Modell Modello	Material Materiale	Ventil sFlow, Typ S Piletta sFlow, tipo S	Artikel-Nr. N. di articolo	Beckentiefe Profondità	Exkl. MWST IVA esclusa	Inkl. MWST IVA inclusa	VRG TRA		
Daneo DAN 34F/7	Edelstahl, matt Acciaio inox, opaco	18 / 10	3 1/2" TouchFlow	10.104.163.00	175 mm	A	1390.–	1503.–	0.19
			3 1/2" Raumspar Salvaspazio	10.104.164.00	175 mm	A	1192.–	1289.–	
			3 1/2" Tipo	10.104.165.00	175 mm	A	1151.–	1244.–	

# Daneo: DAN 34F/7

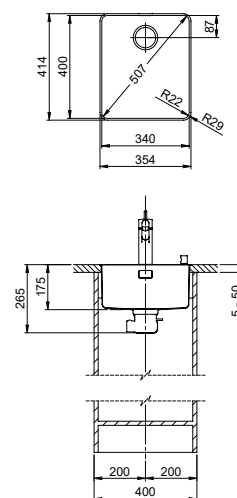
Randbreite 7 mm  
Larghezza bordo 7 mm



eFlow mit eControl  
eFlow con eControl

Schwenkbare Überlaufkappe  
Placchetta di troppopieno a ribalta

Desino: Verdeckter Ablauf mit untenliegendem Korb  
Desino: Scarico coperto con griglietta inferiore



Für eFlow Desino  
Per eFlow Desino

Für TouchFlow Desino, Raumspar Desino und Tipo Desino  
Per TouchFlow Desino, Salvaspazio Desino e Tipo Desino



Für eFlow Desino, TouchFlow Desino, Raumspar Desino und Tipo Desino  
Per eFlow Desino, TouchFlow Desino, Salvaspazio Desino e Tipo Desino

## Optionales Zubehör / Accessori opzionali



**Resteschale gelocht**  
**Vaschetta forata**  
CHF 106.– 40.000.912.00



**Resteschale ungelocht**  
**Vaschetta non forata**  
CHF 106.– 40.001.289.00



**Schneidebrett aus Glas**  
**Tagliere in vetro**  
CHF 151.– 40.000.909.00



**Schneidebrett aus Kunststoff**  
**Tagliere sintetico**  
CHF 151.– 40.001.277.00

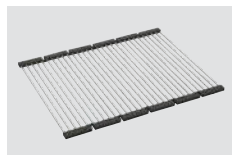

**Inox Pad**  
CHF 125.– 40.001.138.00

Zeichnung als pdf / dxf und Montageanleitung siehe:  
V. disegno in formato pdf / dxf e montaggio:  
suter.ch

**Nur für flächenbündigen Einbau erhältlich.**  
Disponibile solo per montaggio a filo top.

### Flächenbündiger Einbau: Empfehlung zur Wahl der Arbeitsplatte

Wir empfehlen den Einbau in Arbeitsplatten aus Keramik, Granit, Kunststein (z.B. Corian oder Varicor) oder Massivholz. Vom Einbau in beschichtete Spanplatten raten wir ab.

### Montaggio a filo top: Consiglio per la scelta del piano di lavoro

Consigliamo il montaggio nei piani di lavoro in ceramica, granito, pietra artificiale (per es. Corian o Varicor) oppure in legno massiccio. Sconsigliamo la posa in pannelli di truciolato rivestiti.

Varianten: Der Austausch von Zugknöpfen erfolgt mittels Variantencode. Mehr Infos siehe Seite 395.  
Varianti: La sostituzione di pomoli avviene mediante codice variante. Per maggiori informazioni, vedere pag.395.

## Preis CHF / Prezzo in CHF

Modell Modello	Material Materiale	Ventil sFlow, Typ M Piletta sFlow, tipo M	Artikel-Nr. N. di articolo	Beckentiefe Profondità	Exkl. MWST IVA esclusa	Inkl. MWST IVA inclusa	VRG TRA		
<b>Daneo DAN 34F/7</b>	Edelstahl, matt Acciaio inox, opaco	18/10	3 1/2" eFlow Desino	10.104.670.00	175 mm	A	1657.–	1791.–	0.19
			3 1/2" TouchFlow Desino	10.104.643.00	175 mm	A	1542.–	1667.–	0.19
			3 1/2" Raumspar Desino Salvaspazio Desino	10.104.644.00	175 mm	A	1332.–	1440.–	
			3 1/2" Tipo Desino	10.105.696.00	175 mm	A	1332.–	1440.–	

## Daneo: DAN 34IF/12

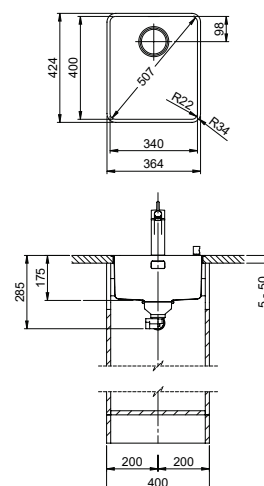
Randbreite 12 mm  
Larghezza bordo 12 mm

 Schwenkbare Überlaufkappe  
Placchetta di troppopieno a ribalta

15

 Obenliegendes Sieb  
Griglietta superiore

14



Zeichnung als pdf / dxf und Montageanleitung siehe:  
V. disegno in formato pdf / dxf e montaggio:  
suter.ch

## Optionales Zubehör / Accessori opzionali

312

**Resteschale gelocht**  
**Vaschetta forato**  
CHF 106.– 40.000.912.00

**Resteschale ungelocht**  
**Vaschetta non forato**  
CHF 106.– 40.001.289.00

**Schneidebrett aus Glas**  
**Tagliere in vetro**  
CHF 151.– 40.000.909.00

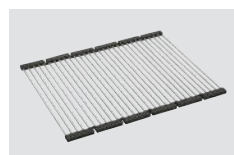
**Schneidebrett aus Kunststoff**  
**Tagliere sintetico**  
CHF 151.– 40.001.277.00

**Inox Pad**  
CHF 125.– 40.001.138.00

**Flächenbündiger Einbau: Empfehlung zur Wahl der Arbeitsplatte**

Wir empfehlen den Einbau in Arbeitsplatten aus Keramik, Granit, Kunststein (z.B. Corian oder Varicor) oder Massivholz. Vom Einbau in beschichtete Spanplatten raten wir ab.

**Montaggio a filo top: Consiglio per la scelta del piano di lavoro**

Consigliamo il montaggio nei piani di lavoro in ceramica, granito, pietra artificiale (per es. Corian o Varicor) oppure in legno massiccio. Sconsigliamo la posa in pannelli di truciolato rivestiti.

**1 Produktausführung, 2 Montagearten**

Der besondere Vorteil von IF-Modellen: Sowohl der flächenbündige Einbau als auch der flach aufliegende Einbau ist möglich.

**1 versione di prodotto, 2 metodi di montaggio**

I modelli IF presentano un grande vantaggio: possono essere posati sia a filo top che sopra piano.

Varianten: Der Austausch von Zugknöpfen erfolgt mittels Variantencode. Mehr Infos siehe Seite 395.  
Varianti: La sostituzione di pomoli avviene mediante codice variante. Per maggiori informazioni, vedere pag. 395.

Preis CHF / Prezzo in CHF

Modell Modello	Material Materiale	Ventil sFlow, Typ S Piletta sFlow, tipo S	Artikel-Nr. N. di articolo	Beckentiefe Profondità	Exkl. MWST IVA esclusa	Inkl. MWST IVA inclusa	VRG TRA		
Daneo DAN 34IF/12	Edelstahl, matt Acciaio inox, opaco	18 / 10	3 1/2" TouchFlow	10.104.200.00	175 mm	A	1090.–	1178.–	0.19
			3 1/2" Raumspar Salvaspazio	10.104.201.00	175 mm	A	892.–	964.–	
			3 1/2" Tipo	10.104.202.00	175 mm	A	851.–	920.–	

# Daneo: DAN 34IF/12

Randbreite 12 mm  
Larghezza bordo 12 mm

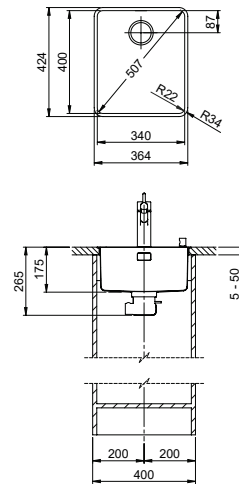

eFlow mit eControl  
eFlow con eControl

Schwenkbare Überlaufkappe  
Placchetta di troppopieno a ribalta

Desino: Verdeckter Ablauf mit untenliegendem Korb  
Desino: Scarico coperto con griglietta inferiore



Für eFlow Desino  
Per eFlow Desino



Für TouchFlow Desino, Raumspar Desino und Tipo Desino  
Per TouchFlow Desino, Salvaspazio Desino e Tipo Desino



Für eFlow Desino, TouchFlow Desino, Raumspar Desino und Tipo Desino  
Per eFlow Desino, TouchFlow Desino, Salvaspazio Desino e Tipo Desino



## Optionales Zubehör / Accessori opzionali



**Resteschale gelocht**  
Vaschetta forato  
CHF 106.– 40.000.912.00



**Resteschale ungelocht**  
Vaschetta non forato  
CHF 106.– 40.001.289.00



**Schneidebrett aus Glas**  
Tagliere in vetro  
CHF 151.– 40.000.909.00



**Schneidebrett aus Kunststoff**  
Tagliere sintetico  
CHF 151.– 40.001.277.00

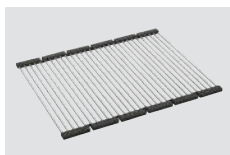

**Inox Pad**  
CHF 125.– 40.001.138.00

Zeichnung als pdf / dxf und Montageanleitung siehe:  
V. disegno in formato pdf / dxf e montaggio:  
suter.ch

**Flächenbündiger Einbau: Empfehlung zur Wahl der Arbeitsplatte**  
Wir empfehlen den Einbau in Arbeitsplatten aus Keramik, Granit, Kunststein (z.B. Corian oder Varicor) oder Massivholz. Vom Einbau in beschichtete Spanplatten raten wir ab.  
**Montaggio a filo top: Consiglio per la scelta del piano di lavoro**  
Consigliamo il montaggio nei piani di lavoro in ceramica, granito, pietra artificiale (per es. Corian o Varicor) oppure in legno massiccio. Sconsigliamo la posa in pannelli di truciolato rivestiti.

**1 Produktausführung, 2 Montagearten**  
Der besondere Vorteil von IF-Modellen: Sowohl der flächenbündige Einbau als auch der flach aufliegende Einbau ist möglich.  
**1 versione di prodotto, 2 metodi di montaggio**  
I modelli IF presentano un grande vantaggio: possono essere posati sia a filo top che sopra piano.

**!** Varianten: Der Austausch von Zugknöpfen erfolgt mittels Variantencode. Mehr Infos siehe Seite 395.  
Varianti: La sostituzione di pomoli avviene mediante codice variante. Per maggiori informazioni, vedere pag. 395.

## Preis CHF / Prezzo in CHF

Modell Modello	Material Materiale	Ventil sFlow, Typ M Piletta sFlow, tipo M	Artikel-Nr. N. di articolo	Beckentiefe Profondità	Exkl. MWST IVA esclusa	Inkl. MWST IVA inclusa	VRG TRA	
<b>Daneo DAN 34IF/12</b>	Edelstahl, matt Acciaio inox, opaco	18/10	3 1/2" eFlow Desino	10.104.671.00	175 mm	A 1357.–	1467.–	0.19
			3 1/2" TouchFlow Desino	10.104.645.00	175 mm	A 1242.–	1343.–	0.19
			3 1/2" Raumspar Desino Salvaspazio Desino	10.104.646.00	175 mm	A 1032.–	1116.–	
			3 1/2" Tipo Desino	10.105.700.00	175 mm	A 1032.–	1116.–	

## Daneo: DAN 40F/7

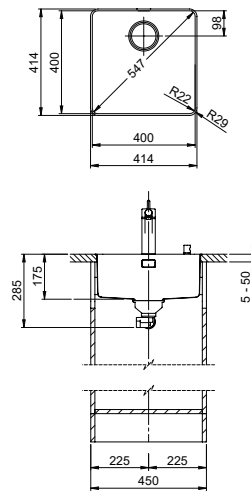
Randbreite 7 mm  
Larghezza bordo 7 mm

 Schwenkbare Überlaufkappe  
Placchetta di troppopieno a ribalta

15

 Obenliegendes Sieb  
Griglietta superiore

14



Zeichnung als pdf / dxf und Montageanleitung siehe:  
V. disegno in formato pdf / dxf e montaggio:  
suter.ch

## Optionales Zubehör/Accessori opzionali

312

**Resteschale gelocht**  
**Vaschetta forato**  
CHF 106.– 40.000.912.00

**Resteschale ungelocht**  
**Vaschetta non forato**  
CHF 106.– 40.001.289.00

**Schneidebrett aus Glas**  
**Tagliere in vetro**  
CHF 151.– 40.000.909.00

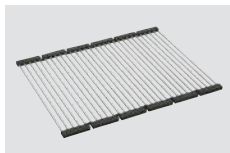
**Schneidebrett aus Kunststoff**  
**Tagliere sintetico**  
CHF 151.– 40.001.277.00

**Inox Pad**  
CHF 125.– 40.001.138.00

**Nur für flächenbündigen Einbau erhältlich.**  
Disponibile solo per montaggio a filo top.

**Flächenbündiger Einbau: Empfehlung zur Wahl der Arbeitsplatte**

Wir empfehlen den Einbau in Arbeitsplatten aus Keramik, Granit, Kunststein (z.B. Corian oder Varicor) oder Massivholz. Vom Einbau in beschichtete Spanplatten raten wir ab.

**Montaggio a filo top: Consiglio per la scelta del piano di lavoro**

Consigliamo il montaggio nei piani di lavoro in ceramica, granito, pietra artificiale (per es. Corian o Varicor) oppure in legno massiccio. Sconsigliamo la posa in pannelli di truciolato rivestiti.

 Varianten: Der Austausch von Zugknöpfen erfolgt mittels Variantencode. Mehr Infos siehe Seite 395.  
Varianti: La sostituzione di pomoli avviene mediante codice variante. Per maggiori informazioni, vedere pag. 395.

## Preis CHF/Prezzo in CHF

Modell Modello	Material Materiale	Ventil sFlow, Typ S Piletta sFlow, tipo S	Artikel-Nr. N. di articolo	Beckentiefe Profondità	Exkl. MWST IVA esclusa	Inkl. MWST IVA inclusa	VRG TRA		
Daneo DAN 40F/7	Edelstahl, matt Acciaio inox, opaco	18 / 10	3 1/2" TouchFlow	10.104.166.00	175 mm	A	1457.–	1575.–	0.19
			3 1/2" Raumspar Salvaspazio	10.104.167.00	175 mm	A	1259.–	1361.–	
			3 1/2" Tipo	10.104.168.00	175 mm	A	1218.–	1317.–	

# Daneo: DAN 40F/7

Randbreite 7 mm  
Larghezza bordo 7 mm

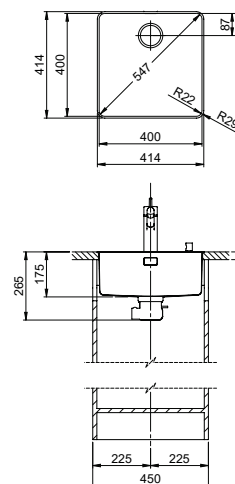

eFlow mit eControl  
eFlow con eControl

Schwenkbare Überlaufkappe  
Placchetta di troppopieno a ribalta

Desino: Verdeckter Ablauf mit untenliegendem Korb  
Desino: Scarico coperto con griglietta inferiore



Für eFlow Desino  
Per eFlow Desino

Für TouchFlow Desino, Raumspar Desino und Tipo Desino  
Per TouchFlow Desino, Salvaspazio Desino e Tipo Desino

Für eFlow Desino, TouchFlow Desino, Raumspar Desino und Tipo Desino  
Per eFlow Desino, TouchFlow Desino, Salvaspazio Desino e Tipo Desino

## Optionales Zubehör/Accessori opzionali

312



**Resteschale gelocht**  
Vaschetta forata  
CHF 106.– 40.000.912.00



**Resteschale ungelocht**  
Vaschetta non forata  
CHF 106.– 40.001.289.00



**Schneidebrett aus Glas**  
Tagliere in vetro  
CHF 151.– 40.000.909.00



**Schneidebrett aus Kunststoff**  
Tagliere sintetico  
CHF 151.– 40.001.277.00

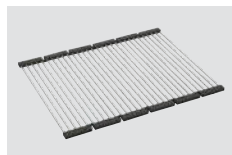

**Inox Pad**  
CHF 125.– 40.001.138.00

**Nur für flächenbündigen Einbau erhältlich.**  
Disponibile solo per montaggio a filo top.

### Flächenbündiger Einbau: Empfehlung zur Wahl der Arbeitsplatte

Wir empfehlen den Einbau in Arbeitsplatten aus Keramik, Granit, Kunststein (z.B. Corian oder Varicor) oder Massivholz. Vom Einbau in beschichtete Spanplatten raten wir ab.

### Montaggio a filo top: Consiglio per la scelta del piano di lavoro

Consigliamo il montaggio nei piani di lavoro in ceramica, granito, pietra artificiale (per es. Corian o Varicor) oppure in legno massiccio. Sconsigliamo la posa in pannelli di truciolato rivestiti.

Varianten: Der Austausch von Zugknöpfen erfolgt mittels Variantencode. Mehr Infos siehe Seite 395.  
Varianti: La sostituzione di pomoli avviene mediante codice variante. Per maggiori informazioni, vedere pag. 395.

## Preis CHF/Prezzo in CHF

Modell Modello	Material Materiale	Ventil sFlow, Typ M Piletta sFlow, tipo M	Artikel-Nr. N. di articolo	Beckentiefe Profondità	Exkl. MWST IVA esclusa	Inkl. MWST IVA inclusa	VRG TRA	
<b>Daneo DAN 40F/7</b>	Edelstahl, matt Acciaio inox, opaco	18/10	3 1/2" eFlow Desino	10.104.672.00	175 mm	A 1724.–	1864.–	0.19
			3 1/2" TouchFlow Desino	10.104.647.00	175 mm	A 1609.–	1739.–	0.19
			3 1/2" Raumspar Desino Salvaspazio Desino	10.104.648.00	175 mm	A 1399.–	1512.–	
			3 1/2" Tipo Desino	10.105.704.00	175 mm	A 1399.–	1512.–	

## Daneo: DAN 40IF/12

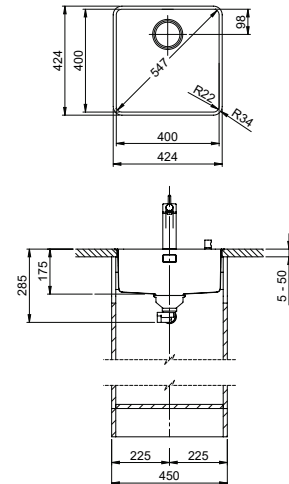
Randbreite 12 mm  
Larghezza bordo 12 mm

 Schwenkbare Überlaufkappe  
Placchetta di troppieno a ribalta

15

 Obenliegendes Sieb  
Griglietta superiore

14



Zeichnung als pdf / dxf und Montageanleitung siehe:  
V. disegno in formato pdf / dxf e montaggio:  
suter.ch

## Optionales Zubehör / Accessori opzionali

312

**Resteschale gelocht**  
**Vaschetta forato**  
CHF 106.– 40.000.912.00

**Resteschale ungelocht**  
**Vaschetta non forato**  
CHF 106.– 40.001.289.00

**Schneidebrett aus Glas**  
**Tagliere in vetro**  
CHF 151.– 40.000.909.00

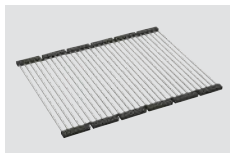
**Schneidebrett aus Kunststoff**  
**Tagliere sintetico**  
CHF 151.– 40.001.277.00

**Inox Pad**  
CHF 125.– 40.001.138.00

**Flächenbündiger Einbau: Empfehlung zur Wahl der Arbeitsplatte**

Wir empfehlen den Einbau in Arbeitsplatten aus Keramik, Granit, Kunststein (z.B. Corian oder Varicor) oder Massivholz. Vom Einbau in beschichtete Spanplatten raten wir ab.

**Montaggio a filo top: Consiglio per la scelta del piano di lavoro**

Consigliamo il montaggio nei piani di lavoro in ceramica, granito, pietra artificiale (per es. Corian o Varicor) oppure in legno massiccio. Sconsigliamo la posa in pannelli di truciolato rivestiti.

**1 Produktausführung, 2 Montagearten**

Der besondere Vorteil von IF-Modellen: Sowohl der flächenbündige Einbau als auch der flach aufliegende Einbau ist möglich.

**1 versione di prodotto, 2 metodi di montaggio**

I modelli IF presentano un grande vantaggio: possono essere posati sia a filo top che sopra piano.

**Varianten:** Der Austausch von Zugknöpfen erfolgt mittels Variantencode. Mehr Infos siehe Seite 395.  
**Varianti:** La sostituzione di pomoli avviene mediante codice variante. Per maggiori informazioni, vedere pag. 395.

Preis CHF / Prezzo in CHF

Modell Modello	Material Materiale	Ventil sFlow, Typ S Piletta sFlow, tipo S	Artikel-Nr. N. di articolo	Beckentiefe Profondità	Exkl. MWST IVA esclusa	Inkl. MWST IVA inclusa	VRG TRA		
<b>Daneo DAN 40IF/12</b>	Edelstahl, matt Acciaio inox, opaco	18 / 10	3 1/2" TouchFlow	10.104.203.00	175 mm	A	1140.–	1232.–	0.19
			3 1/2" Raumspar Salvaspazio	10.104.204.00	175 mm	A	942.–	1018.–	
			3 1/2" Tipo	10.104.205.00	175 mm	A	901.–	974.–	

# Daneo: DAN 40IF/12

Randbreite 12 mm  
Larghezza bordo 12 mm

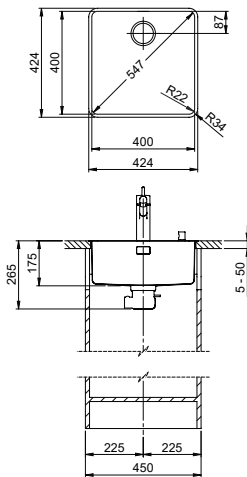

eFlow mit eControl  
eFlow con eControl

Schwenkbare Überlaufkappe  
Placchetta di troppopieno a ribalta

Desino: Verdeckter Ablauf mit untenliegendem Korb  
Desino: Scarico coperto con griglietta inferiore



Für eFlow Desino  
Per eFlow Desino

Für TouchFlow Desino, Raumspar Desino und Tipo Desino  
Per TouchFlow Desino, Salvaspazio Desino e Tipo Desino



Für eFlow Desino, TouchFlow Desino, Raumspar Desino und Tipo Desino  
Per eFlow Desino, TouchFlow Desino, Salvaspazio Desino e Tipo Desino

## Optionales Zubehör / Accessori opzionali



**Resteschale gelocht**  
Vaschetta forato  
CHF 106.– 40.000.912.00



**Resteschale ungelocht**  
Vaschetta non forato  
CHF 106.– 40.001.289.00



**Schneidebrett aus Glas**  
Tagliere in vetro  
CHF 151.– 40.000.909.00



**Schneidebrett aus Kunststoff**  
Tagliere sintetico  
CHF 151.– 40.001.277.00

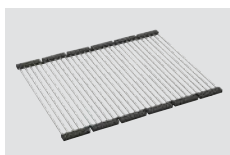

**Inox Pad**  
CHF 125.– 40.001.138.00

Zeichnung als pdf / dxf und Montageanleitung siehe:  
V. disegno in formato pdf / dxf e montaggio:  
suter.ch

**i Flächenbündiger Einbau: Empfehlung zur Wahl der Arbeitsplatte**  
Wir empfehlen den Einbau in Arbeitsplatten aus Keramik, Granit, Kunststein (z.B. Corian oder Varicor) oder Massivholz. Vom Einbau in beschichtete Spanplatten raten wir ab.  
**Montaggio a filo top: Consiglio per la scelta del piano di lavoro**  
Consigliamo il montaggio nei piani di lavoro in ceramica, granito, pietra artificiale (per es. Corian o Varicor) oppure in legno massiccio. Sconsigliamo la posa in pannelli di truciolato rivestiti.

**1 Produktausführung, 2 Montagearten**  
Der besondere Vorteil von IF-Modellen: Sowohl der flächenbündige Einbau als auch der flach aufliegende Einbau ist möglich.  
**1 versione di prodotto, 2 metodi di montaggio**  
I modelli IF presentano un grande vantaggio: possono essere posati sia a filo top che sopra piano.

**!** Varianten: Der Austausch von Zugknöpfen erfolgt mittels Variantencode. Mehr Infos siehe Seite 395.  
Varianti: La sostituzione di pomoli avviene mediante codice variante. Per maggiori informazioni, vedere pag. 395.

## Preis CHF / Prezzo in CHF

Modell Modello	Material Materiale	Ventil sFlow, Typ M Piletta sFlow, tipo M	Artikel-Nr. N. di articolo	Beckentiefe Profondità	Exkl. MWST IVA esclusa	Inkl. MWST IVA inclusa	VRG TRA
<b>Daneo DAN 40IF/12</b>	Edelstahl, matt Acciaio inox, opaco	3 1/2" eFlow Desino	10.104.673.00	175 mm	A 1407.–	1521.–	0.19
		3 1/2" TouchFlow Desino	10.104.649.00	175 mm	A 1292.–	1397.–	0.19
		3 1/2" Raumspar Desino Salvaspazio Desino	10.104.650.00	175 mm	A 1082.–	1170.–	
		3 1/2" Tipo Desino	10.105.708.00	175 mm	A 1082.–	1170.–	

## Daneo: DAN 45F/7

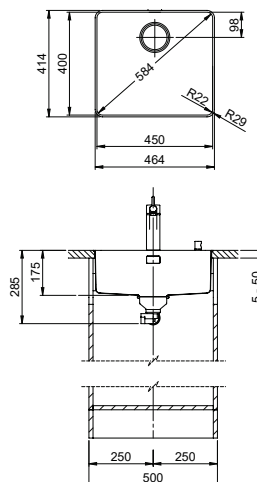
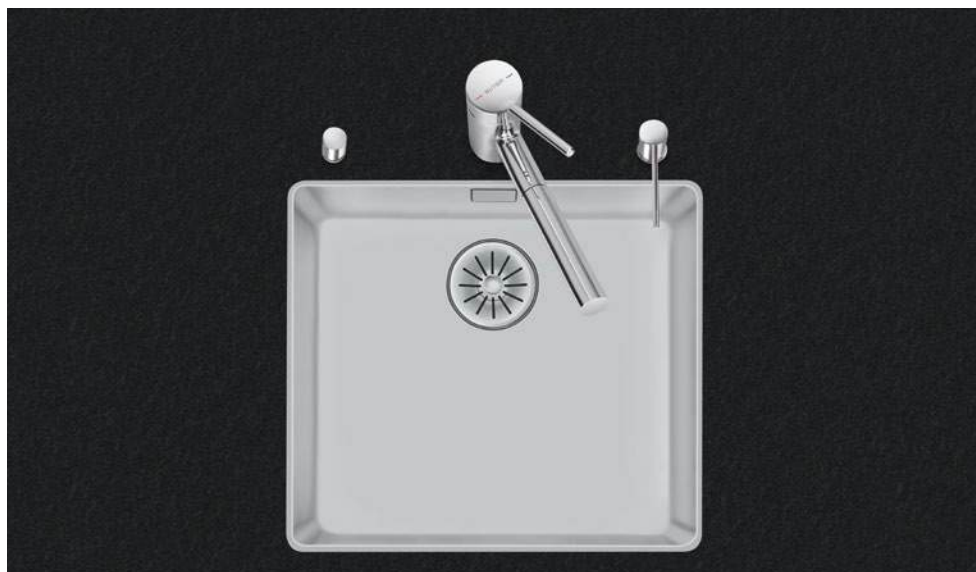
Randbreite 7 mm  
Larghezza bordo 7 mm

 Schwenkbare Überlaufkappe  
Placchetta di troppieno a ribalta

15

 Obenliegendes Sieb  
Griglietta superiore

14

 Zeichnung als pdf / dxf und Montageanleitung siehe:  
V. disegno in formato pdf / dxf e montaggio:  
suter.ch

## Optionales Zubehör/Accessori opzionali

312

**Resteschale gelocht**  
**Vaschetta forato**  
CHF 106.– 40.000.912.00

**Resteschale ungelocht**  
**Vaschetta non forato**  
CHF 106.– 40.001.289.00

**Schneidebrett aus Glas**  
**Tagliere in vetro**  
CHF 151.– 40.000.909.00

**Schneidebrett aus Kunststoff**  
**Tagliere sintetico**  
CHF 151.– 40.001.277.00



**Nur für flächenbündigen Einbau erhältlich.**  
Disponibile solo per montaggio a filo top.

**Flächenbündiger Einbau: Empfehlung zur Wahl der Arbeitsplatte**

Wir empfehlen den Einbau in Arbeitsplatten aus Keramik, Granit, Kunststein (z.B. Corian oder Varicor) oder Massivholz. Vom Einbau in beschichtete Spanplatten raten wir ab.

**Montaggio a filo top: Consiglio per la scelta del piano di lavoro**

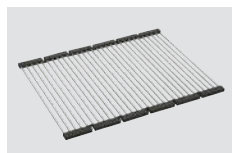
Consigliamo il montaggio nei piani di lavoro in ceramica, granito, pietra artificiale (per es. Corian o Varicor) oppure in legno massiccio. Sconsigliamo la posa in pannelli di truciolato rivestiti.

**Inox Pad**  
CHF 125.– 40.001.138.00



 Varianten: Der Austausch von Zugknöpfen erfolgt mittels Variantencode. Mehr Infos siehe Seite 395.  
Varianti: La sostituzione di pomoli avviene mediante codice variante. Per maggiori informazioni, vedere pag. 395.

Preis CHF/Prezzo in CHF

Modell Modello	Material Materiale	Ventil sFlow, Typ S Piletta sFlow, tipo S	Artikel-Nr. N. di articolo	Beckentiefe Profondità	Exkl. MWST IVA esclusa	Inkl. MWST IVA inclusa	VRG TRA		
Daneo DAN 45F/7	Edelstahl, matt Acciaio inox, opaco	18 / 10	3 1/2" TouchFlow	10.104.169.00	175 mm	A	1483.–	1603.–	0.19
			3 1/2" Raumspar Salvaspazio	10.104.170.00	175 mm	A	1285.–	1389.–	
			3 1/2" Tipo	10.104.171.00	175 mm	A	1244.–	1345.–	

# Daneo: DAN 45F/7

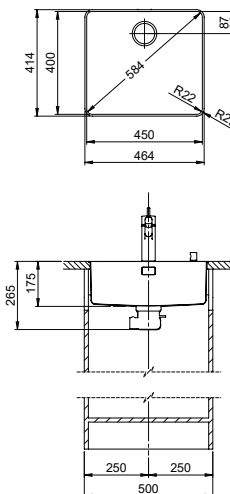
Randbreite 7 mm  
Larghezza bordo 7 mm



eFlow mit eControl  
eFlow con eControl

Schwenkbare Überlaufkappe  
Placchetta di troppopieno a ribalta

Desino: Verdeckter Ablauf mit untenliegendem Korb  
Desino: Scarico coperto con griglietta inferiore



Für eFlow Desino  
Per eFlow Desino

Für TouchFlow Desino, Raumspar Desino und Tipo Desino  
Per TouchFlow Desino, Salvaspazio Desino e Tipo Desino



Für eFlow Desino, TouchFlow Desino, Raumspar Desino und Tipo Desino  
Per eFlow Desino, TouchFlow Desino, Salvaspazio Desino e Tipo Desino

## Optionales Zubehör/Accessori opzionali

312



**Resteschale gelocht**  
Vaschetta forato  
CHF 106.- 40.000.912.00



**Resteschale ungelocht**  
Vaschetta non forato  
CHF 106.- 40.001.289.00



**Schneidebrett aus Glas**  
Tagliere in vetro  
CHF 151.- 40.000.909.00



**Schneidebrett aus Kunststoff**  
Tagliere sintetico  
CHF 151.- 40.001.277.00

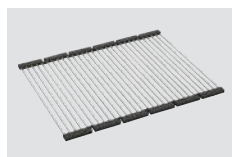

**Inox Pad**  
CHF 125.- 40.001.138.00

**Nur für flächenbündigen Einbau erhältlich.**  
Disponibile solo per montaggio a filo top.

### Flächenbündiger Einbau: Empfehlung zur Wahl der Arbeitsplatte

Wir empfehlen den Einbau in Arbeitsplatten aus Keramik, Granit, Kunststoff (z.B. Corian oder Varicor) oder Massivholz. Vom Einbau in beschichtete Spanplatten raten wir ab.

### Montaggio a filo top: Consiglio per la scelta del piano di lavoro

Consigliamo il montaggio nei piani di lavoro in ceramica, granito, pietra artificiale (per es. Corian o Varicor) oppure in legno massiccio. Sconsigliamo la posa in pannelli di truciolato rivestiti.

Varianten: Der Austausch von Zugknöpfen erfolgt mittels Variantencode. Mehr Infos siehe Seite 395.  
Varianti: La sostituzione di pomoli avviene mediante codice variante. Per maggiori informazioni, vedere pag. 395.

## Preis CHF/Prezzo in CHF

Modell Modello	Material Materiale	Ventil sFlow, Typ M Piletta sFlow, tipo M	Artikel-Nr. N. di articolo	Beckentiefe Profondità	Exkl. MWST IVA esclusa	Inkl. MWST IVA inclusa	VRG TRA		
<b>Daneo DAN 45F/7</b>	Edelstahl, matt Acciaio inox, opaco	18/10	3 1/2" eFlow Desino	10.104.674.00	175 mm	A	1750.-	1892.-	0.19
			3 1/2" TouchFlow Desino	10.104.651.00	175 mm	A	1635.-	1767.-	0.19
			3 1/2" Raumspar Desino Salvaspazio Desino	10.104.652.00	175 mm	A	1425.-	1540.-	
			3 1/2" Tipo Desino	10.105.712.00	175 mm	A	1425.-	1540.-	

## Daneo: DAN 45IF/12

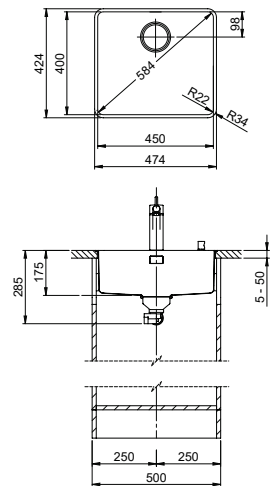
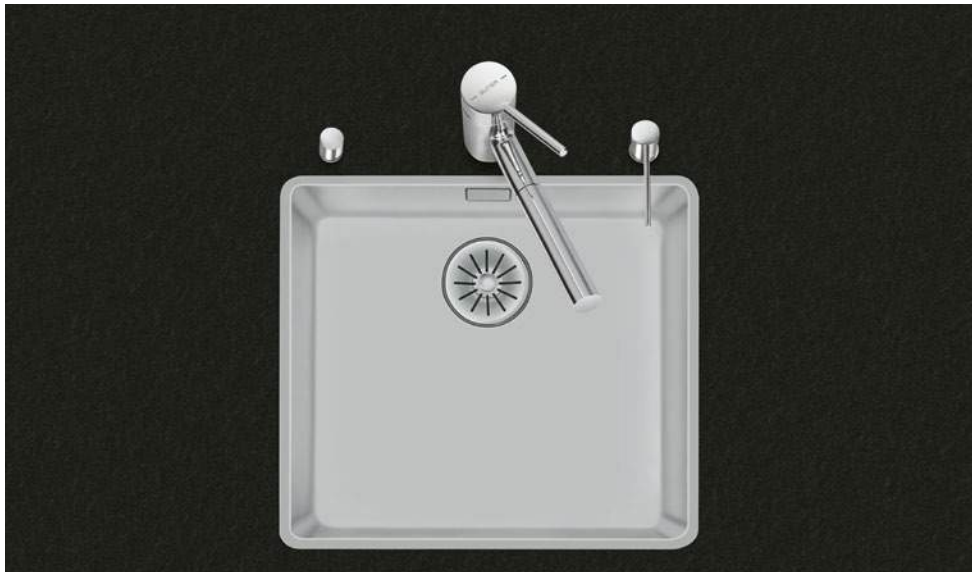
Randbreite 12 mm  
Larghezza bordo 12 mm

 Schwenkbare Überlaufkappe  
Placchetta di troppopieno a ribalta

15

 Obenliegendes Sieb  
Griglietta superiore

14



Zeichnung als pdf / dxf und Montageanleitung siehe:  
V. disegno in formato pdf / dxf e montaggio:  
suter.ch

## Optionales Zubehör / Accessori opzionali

312

**Resteschale gelocht**  
**Vaschetta forato**  
CHF 106.– 40.000.912.00

**Resteschale ungelocht**  
**Vaschetta non forato**  
CHF 106.– 40.001.289.00

**Schneidebrett aus Glas**  
**Tagliere in vetro**  
CHF 151.– 40.000.909.00

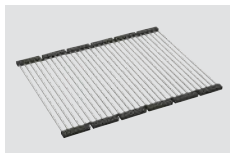
**Schneidebrett aus Kunststoff**  
**Tagliere sintetico**  
CHF 151.– 40.001.277.00

**Inox Pad**  
CHF 125.– 40.001.138.00

**Flächenbündiger Einbau: Empfehlung zur Wahl der Arbeitsplatte**

Wir empfehlen den Einbau in Arbeitsplatten aus Keramik, Granit, Kunststein (z.B. Corian oder Varicor) oder Massivholz. Vom Einbau in beschichtete Spanplatten raten wir ab.

**Montaggio a filo top: Consiglio per la scelta del piano di lavoro**

Consigliamo il montaggio nei piani di lavoro in ceramica, granito, pietra artificiale (per es. Corian o Varicor) oppure in legno massiccio. Sconsigliamo la posa in pannelli di truciolato rivestiti.

**1 Produktausführung, 2 Montagearten**

Der besondere Vorteil von IF-Modellen: Sowohl der flächenbündige Einbau als auch der flach aufliegende Einbau ist möglich.

**1 versione di prodotto, 2 metodi di montaggio**

I modelli IF presentano un grande vantaggio: possono essere posati sia a filo top che sopra piano.

**Varianten:** Der Austausch von Zugknöpfen erfolgt mittels Variantencode. Mehr Infos siehe Seite 395.  
**Varianti:** La sostituzione di pomoli avviene mediante codice variante. Per maggiori informazioni, vedere pag. 395.

Preis CHF / Prezzo in CHF

Modell Modello	Material Materiale	Ventil sFlow, Typ S Piletta sFlow, tipo S	Artikel-Nr. N. di articolo	Beckentiefe Profondità	Exkl. MWST IVA esclusa	Inkl. MWST IVA inclusa	VRG TRA		
<b>Daneo DAN 45IF/12</b>	Edelstahl, matt Acciaio inox, opaco	18 / 10	3 1/2" TouchFlow	10.104.206.00	175 mm	A	1152.–	1245.–	0.19
			3 1/2" Raumspar Salvaspazio	10.104.207.00	175 mm	A	954.–	1031.–	
			3 1/2" Tipo	10.104.208.00	175 mm	A	913.–	987.–	

# Daneo: DAN 45IF/12

Randbreite 12 mm  
Larghezza bordo 12 mm

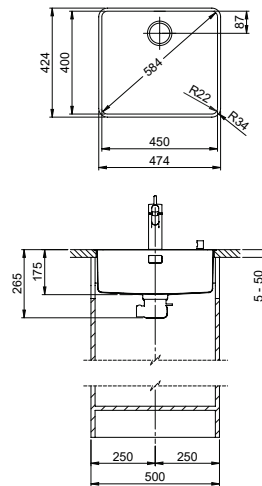

eFlow mit eControl  
eFlow con eControl

Schwenkbare Überlaufkappe  
Placchetta di troppopieno a ribalta

Desino: Verdeckter Ablauf mit untenliegendem Korb  
Desino: Scarico coperto con griglietta inferiore



Für eFlow Desino  
Per eFlow Desino

Für TouchFlow Desino, Raumspaar Desino und Typo Desino  
Per TouchFlow Desino, Salvaspazio Desino e Typo Desino



Für eFlow Desino, TouchFlow Desino, Raumspaar Desino und Typo Desino  
Per eFlow Desino, TouchFlow Desino, Salvaspazio Desino e Typo Desino

## Optionales Zubehör / Accessori opzionali



**Resteschale gelocht**  
Vaschetta forato  
CHF 106.– 40.000.912.00



**Resteschale ungelocht**  
Vaschetta non forato  
CHF 106.– 40.001.289.00



**Schneidebrett aus Glas**  
Tagliere in vetro  
CHF 151.– 40.000.909.00



**Schneidebrett aus Kunststoff**  
Tagliere sintetico  
CHF 151.– 40.001.277.00

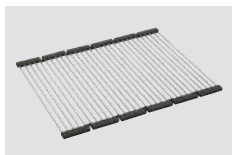

**Inox Pad**  
CHF 125.– 40.001.138.00

Zeichnung als pdf / dxf und Montageanleitung siehe:  
V. disegno in formato pdf / dxf e montaggio:  
suter.ch

**Flächenbündiger Einbau: Empfehlung zur Wahl der Arbeitsplatte**  
Wir empfehlen den Einbau in Arbeitsplatten aus Keramik, Granit, Kunststein (z.B. Corian oder Varicor) oder Massivholz. Vom Einbau in beschichtete Spanplatten raten wir ab.  
**Montaggio a filo top: Consiglio per la scelta del piano di lavoro**  
Consigliamo il montaggio nei piani di lavoro in ceramica, granito, pietra artificiale (per es. Corian o Varicor) oppure in legno massiccio. Sconsigliamo la posa in pannelli di truciolato rivestiti.

**1 Produktausführung, 2 Montagearten**  
Der besondere Vorteil von IF-Modellen: Sowohl der flächenbündige Einbau als auch der flach aufliegende Einbau ist möglich.  
**1 versione di prodotto, 2 metodi di montaggio**  
I modelli IF presentano un grande vantaggio: possono essere posati sia a filo top che sopra piano.

**!** Varianten: Der Austausch von Zugknöpfen erfolgt mittels Variantencode. Mehr Infos siehe Seite 395.  
Varianti: La sostituzione di pomoli avviene mediante codice variante. Per maggiori informazioni, vedere pag. 395.

## Preis CHF / Prezzo in CHF

Modell Modello	Material Materiale	Ventil sFlow, Typ M Piletta sFlow, tipo M	Artikel-Nr. N. di articolo	Beckentiefe Profondità	Exkl. MWST IVA esclusa	Inkl. MWST IVA inclusa	VRG TRA	
<b>Daneo DAN 45IF/12</b>	Edelstahl, matt Acciaio inox, opaco	3 1/2" eFlow Desino	10.104.675.00	175 mm	A	1419.–	1534.–	0.19
		3 1/2" TouchFlow Desino	10.104.653.00	175 mm	A	1304.–	1410.–	0.19
		3 1/2" Raumspaar Desino Salvaspazio Desino	10.104.654.00	175 mm	A	1094.–	1183.–	
		3 1/2" Typo Desino	10.105.716.00	175 mm	A	1094.–	1183.–	

## Daneo: DAN 50F/7

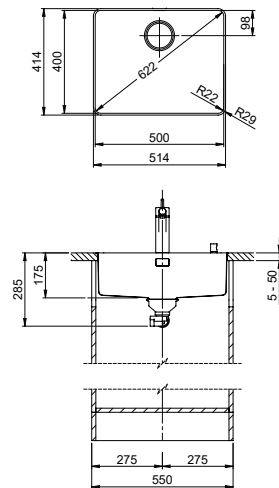
Randbreite 7 mm  
Larghezza bordo 7 mm

 Schwenkbare Überlaufkappe  
Placchetta di troppopieno a ribalta

15

 Obenliegendes Sieb  
Griglietta superiore

14



Zeichnung als pdf / dxf und Montageanleitung siehe:  
V. disegno in formato pdf / dxf e montaggio:  
suter.ch

## Optionales Zubehör/Accessori opzionali

312

**Resteschale gelocht**  
**Vaschetta forato**  
CHF 106.– 40.000.912.00

**Resteschale ungelocht**  
**Vaschetta non forato**  
CHF 106.– 40.001.289.00

**Schneidebrett aus Glas**  
**Tagliere in vetro**  
CHF 151.– 40.000.909.00

**Schneidebrett aus Kunststoff**  
**Tagliere sintetico**  
CHF 151.– 40.001.277.00



**Nur für flächenbündigen Einbau erhältlich.**  
Disponibile solo per montaggio a filo top.

**Flächenbündiger Einbau: Empfehlung zur Wahl der Arbeitsplatte**

Wir empfehlen den Einbau in Arbeitsplatten aus Keramik, Granit, Kunststein (z.B. Corian oder Varicor) oder Massivholz. Vom Einbau in beschichtete Spanplatten raten wir ab.

**Montaggio a filo top: Consiglio per la scelta del piano di lavoro**

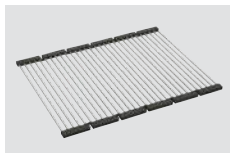
Consigliamo il montaggio nei piani di lavoro in ceramica, granito, pietra artificiale (per es. Corian o Varicor) oppure in legno massiccio. Sconsigliamo la posa in pannelli di truciolato rivestiti.

**Inox Pad**  
CHF 125.– 40.001.138.00



 Varianten: Der Austausch von Zugknöpfen erfolgt mittels Variantencode. Mehr Infos siehe Seite 395.  
Varianti: La sostituzione di pomoli avviene mediante codice variante. Per maggiori informazioni, vedere pag. 395.

Preis CHF/Prezzo in CHF

Modell Modello	Material Materiale	Ventil sFlow, Typ S Piletta sFlow, tipo S	Artikel-Nr. N. di articolo	Beckentiefe Profondità	Exkl. MWST IVA esclusa	Inkl. MWST IVA inclusa	VRG TRA		
Daneo DAN 50F/7	Edelstahl, matt Acciaio inox, opaco	18 / 10	3 1/2" TouchFlow	10.104.172.00	175 mm	A	1509.–	1631.–	0.19
			3 1/2" Raumspar Salvaspazio	10.104.173.00	175 mm	A	1311.–	1417.–	
			3 1/2" Tipo	10.104.174.00	175 mm	A	1270.–	1373.–	

# Daneo: DAN 50F/7

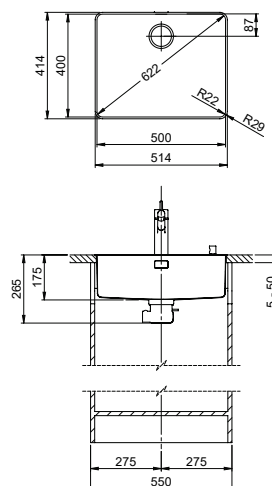
Randbreite 7 mm  
Larghezza bordo 7 mm



eFlow mit eControl  
eFlow con eControl

Schwenkbare Überlaufkappe  
Placchetta di troppopieno a ribalta

Desino: Verdeckter Ablauf mit untenliegendem Korb  
Desino: Scarico coperto con griglietta inferiore



Für eFlow Desino  
Per eFlow Desino

Für TouchFlow Desino, Raumspaar Desino und Typo Desino  
Per TouchFlow Desino, Salvaspazio Desino e Typo Desino



Für eFlow Desino, TouchFlow Desino, Raumspaar Desino und Typo Desino  
Per eFlow Desino, TouchFlow Desino, Salvaspazio Desino e Typo Desino

## Optionales Zubehör / Accessori opzionali

312



**Resteschale gelocht**  
**Vaschetta forata**  
CHF 106.– 40.000.912.00



**Resteschale ungelocht**  
**Vaschetta non forata**  
CHF 106.– 40.001.289.00



**Schneidebrett aus Glas**  
**Tagliere in vetro**  
CHF 151.– 40.000.909.00



**Schneidebrett aus Kunststoff**  
**Tagliere sintetico**  
CHF 151.– 40.001.277.00

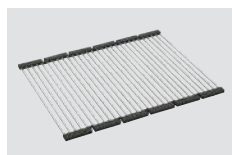

**Inox Pad**  
CHF 125.– 40.001.138.00

Zeichnung als pdf / dxf und Montageanleitung siehe:  
V. disegno in formato pdf / dxf e montaggio:  
suter.ch

**Nur für flächenbündigen Einbau erhältlich.**  
Disponibile solo per montaggio a filo top.

### Flächenbündiger Einbau: Empfehlung zur Wahl der Arbeitsplatte

Wir empfehlen den Einbau in Arbeitsplatten aus Keramik, Granit, Kunststein (z.B. Corian oder Varicor) oder Massivholz. Vom Einbau in beschichtete Spanplatten raten wir ab.

### Montaggio a filo top: Consiglio per la scelta del piano di lavoro

Consigliamo il montaggio nei piani di lavoro in ceramica, granito, pietra artificiale (per es. Corian o Varicor) oppure in legno massiccio. Sconsigliamo la posa in pannelli di truciolato rivestiti.

Varianten: Der Austausch von Zugknöpfen erfolgt mittels Variantencode. Mehr Infos siehe Seite 395.  
Varianti: La sostituzione di pomoli avviene mediante codice variante. Per maggiori informazioni, vedere pag. 395.

## Preis CHF/Prezzo in CHF

Modell Modello	Material Materiale	Ventil sFlow, Typ M Piletta sFlow, tipo M	Artikel-Nr. N. di articolo	Beckentiefe Profondità	Exkl. MWST IVA esclusa	Inkl. MWST IVA inclusa	VRG TRA	
<b>Daneo DAN 50F/7</b>	Edelstahl, matt Acciaio inox, opaco	18/10	3 1/2" eFlow Desino	10.104.676.00	175 mm	A 1776.–	1920.–	0.19
			3 1/2" TouchFlow Desino	10.104.655.00	175 mm	A 1661.–	1796.–	0.19
			3 1/2" Raumspaar Desino Salvaspazio Desino	10.104.656.00	175 mm	A 1451.–	1569.–	
			3 1/2" Typo Desino	10.105.720.00	175 mm	A 1451.–	1569.–	

## Daneo: DAN 50IF/12

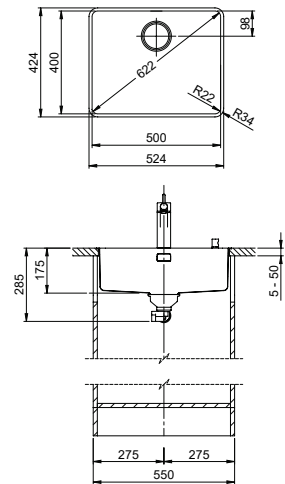
Randbreite 12 mm  
Larghezza bordo 12 mm

 Schwenkbare Überlaufkappe  
Placchetta di troppopieno a ribalta

15

 Obenliegendes Sieb  
Griglietta superiore

14

 Zeichnung als pdf / dxf und Montageanleitung siehe:  
V. disegno in formato pdf / dxf e montaggio:  
suter.ch

## Optionales Zubehör / Accessori opzionali

312

**Resteschale gelocht**  
**Vaschetta forata**  
CHF 106.– 40.000.912.00

**Resteschale ungelocht**  
**Vaschetta non forata**  
CHF 106.– 40.001.289.00

**Schneidebrett aus Glas**  
**Tagliere in vetro**  
CHF 151.– 40.000.909.00

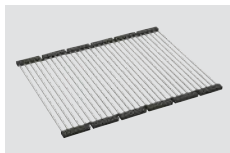
**Schneidebrett aus Kunststoff**  
**Tagliere sintetico**  
CHF 151.– 40.001.277.00

**Inox Pad**  
CHF 125.– 40.001.138.00

**Flächenbündiger Einbau: Empfehlung zur Wahl der Arbeitsplatte**

Wir empfehlen den Einbau in Arbeitsplatten aus Keramik, Granit, Kunststein (z.B. Corian oder Varicor) oder Massivholz. Vom Einbau in beschichtete Spanplatten raten wir ab.

**Montaggio a filo top: Consiglio per la scelta del piano di lavoro**

Consigliamo il montaggio nei piani di lavoro in ceramica, granito, pietra artificiale (per es. Corian o Varicor) oppure in legno massiccio. Sconsigliamo la posa in pannelli di truciolato rivestiti.

**1 Produktausführung, 2 Montagearten**

Der besondere Vorteil von IF-Modellen: Sowohl der flächenbündige Einbau als auch der flach aufliegende Einbau ist möglich.

**1 versione di prodotto, 2 metodi di montaggio**

I modelli IF presentano un grande vantaggio: possono essere posati sia a filo top che sopra piano.

 Varianten: Der Austausch von Zugknöpfen erfolgt mittels Variantencode. Mehr Infos siehe Seite 395.  
Varianti: La sostituzione di pomoli avviene mediante codice variante. Per maggiori informazioni, vedere pag. 395.

Preis CHF / Prezzo in CHF

Modell Modello	Material Materiale	Ventil sFlow, Typ S Piletta sFlow, tipo S	Artikel-Nr. N. di articolo	Beckentiefe Profondità	Exkl. MWST IVA esclusa	Inkl. MWST IVA inclusa	VRG TRA		
Daneo DAN 50IF/12	Edelstahl, matt Acciaio inox, opaco	18 / 10	3 1/2" TouchFlow	10.104.209.00	175 mm	A	1296.–	1401.–	0.19
			3 1/2" Raumspar Salvaspazio	10.104.210.00	175 mm	A	1098.–	1187.–	
			3 1/2" Tipo	10.104.211.00	175 mm	A	1057.–	1143.–	

# Daneo: DAN 50IF/12

Randbreite 12 mm  
Larghezza bordo 12 mm

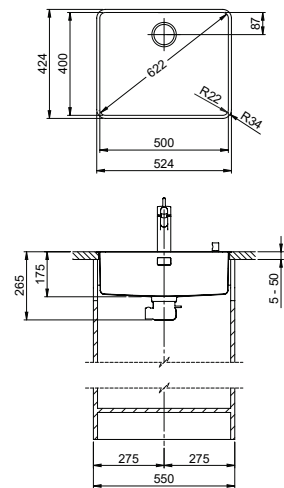

eFlow mit eControl  
eFlow con eControl

Schwenkbare Überlaufkappe  
Placchetta di troppopieno a ribalta

Desino: Verdeckter Ablauf mit untenliegendem Korb  
Desino: Scarico coperto con griglietta inferiore



Für eFlow Desino  
Per eFlow Desino

Für TouchFlow Desino, Raumspar Desino und Tipo Desino  
Per TouchFlow Desino, Salvaspazio Desino e Tipo Desino

Für eFlow Desino, TouchFlow Desino, Raumspar Desino und Tipo Desino  
Per eFlow Desino, TouchFlow Desino, Salvaspazio Desino e Tipo Desino

## Optionales Zubehör / Accessori opzionali



**Resteschale gelocht**  
Vaschetta forato  
CHF 106.– 40.000.912.00



**Resteschale ungelocht**  
Vaschetta non forato  
CHF 106.– 40.001.289.00



**Schneidebrett aus Glas**  
Tagliere in vetro  
CHF 151.– 40.000.909.00



**Schneidebrett aus Kunststoff**  
Tagliere sintetico  
CHF 151.– 40.001.277.00

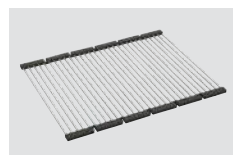

**Inox Pad**  
CHF 125.– 40.001.138.00

Zeichnung als pdf / dxf und Montageanleitung siehe:  
V. disegno in formato pdf / dxf e montaggio:  
suter.ch

**Flächenbündiger Einbau: Empfehlung zur Wahl der Arbeitsplatte**  
Wir empfehlen den Einbau in Arbeitsplatten aus Keramik, Granit, Kunststein (z.B. Corian oder Varicor) oder Massivholz. Vom Einbau in beschichtete Spanplatten raten wir ab.  
**Montaggio a filo top: Consiglio per la scelta del piano di lavoro**  
Consigliamo il montaggio nei piani di lavoro in ceramica, granito, pietra artificiale (per es. Corian o Varicor) oppure in legno massiccio. Sconsigliamo la posa in pannelli di truciolato rivestiti.

**1 Produktausführung, 2 Montagearten**  
Der besondere Vorteil von IF-Modellen: Sowohl der flächenbündige Einbau als auch der flach aufliegende Einbau ist möglich.  
**1 versione di prodotto, 2 metodi di montaggio**  
I modelli IF presentano un grande vantaggio: possono essere posati sia a filo top che sopra piano.

Varianten: Der Austausch von Zugknöpfen erfolgt mittels Variantencode. Mehr Infos siehe Seite 395.  
Varianti: La sostituzione di pomoli avviene mediante codice variante. Per maggiori informazioni, vedere pag. 395.

## Preis CHF / Prezzo in CHF

Modell Modello	Material Materiale	Ventil sFlow, Typ M Piletta sFlow, tipo M	Artikel-Nr. N. di articolo	Beckentiefe Profondità	Exkl. MWST IVA esclusa	Inkl. MWST IVA inclusa	VRG TRA	
<b>Daneo DAN 50IF/12</b>	Edelstahl, matt Acciaio inox, opaco	3 1/2" eFlow Desino	10.104.677.00	175 mm	A	1563.–	1690.–	0.19
		3 1/2" TouchFlow Desino	10.104.657.00	175 mm	A	1448.–	1565.–	0.19
		3 1/2" Raumspar Desino Salvaspazio Desino	10.104.658.00	175 mm	A	1238.–	1338.–	
		3 1/2" Tipo Desino	10.105.724.00	175 mm	A	1238.–	1338.–	

## Daneo: DAN 55F/7

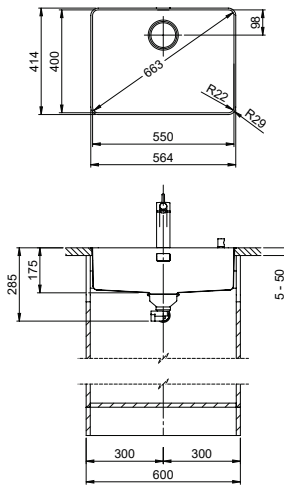
Randbreite 7 mm  
Larghezza bordo 7 mm

 Schwenkbare Überlaufkappe  
Placchetta di troppopieno a ribalta

15

 Obenliegendes Sieb  
Griglietta superiore

14



Zeichnung als pdf / dxf und Montageanleitung siehe:  
V. disegno in formato pdf / dxf e montaggio:  
suter.ch

## Optionales Zubehör/Accessori opzionali

312

**Resteschale gelocht**  
**Vaschetta forato**  
CHF 106.– 40.000.912.00

**Resteschale ungelocht**  
**Vaschetta non forato**  
CHF 106.– 40.001.289.00

**Schneidebrett aus Glas**  
**Tagliere in vetro**  
CHF 151.– 40.000.909.00

**Schneidebrett aus Kunststoff**  
**Tagliere sintetico**  
CHF 151.– 40.001.277.00



**Nur für flächenbündigen Einbau erhältlich.**  
Disponibile solo per montaggio a filo top.

**Flächenbündiger Einbau: Empfehlung zur Wahl der Arbeitsplatte**

Wir empfehlen den Einbau in Arbeitsplatten aus Keramik, Granit, Kunststein (z.B. Corian oder Varicor) oder Massivholz. Vom Einbau in beschichtete Spanplatten raten wir ab.

**Montaggio a filo top: Consiglio per la scelta del piano di lavoro**

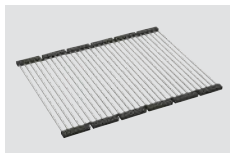
Consigliamo il montaggio nei piani di lavoro in ceramica, granito, pietra artificiale (per es. Corian o Varicor) oppure in legno massiccio. Sconsigliamo la posa in pannelli di truciolato rivestiti.

**Inox Pad**  
CHF 125.– 40.001.138.00



 Varianten: Der Austausch von Zugknöpfen erfolgt mittels Variantencode. Mehr Infos siehe Seite 395.  
Varianti: La sostituzione di pomoli avviene mediante codice variante. Per maggiori informazioni, vedere pag. 395.

Preis CHF/Prezzo in CHF

Modell Modello	Material Materiale	Ventil sFlow, Typ S Piletta sFlow, tipo S	Artikel-Nr. N. di articolo	Beckentiefe Profondità	Exkl. MWST IVA esclusa	Inkl. MWST IVA inclusa	VRG TRA		
Daneo DAN 55F/7	Edelstahl, matt Acciaio inox, opaco	18 / 10	3 1/2" TouchFlow	10.104.175.00	175 mm	A	1602.–	1732.–	0.19
			3 1/2" Raumspar Salvaspazio	10.104.176.00	175 mm	A	1404.–	1518.–	
			3 1/2" Tipo	10.104.177.00	175 mm	A	1363.–	1473.–	

# Daneo: DAN 55F/7

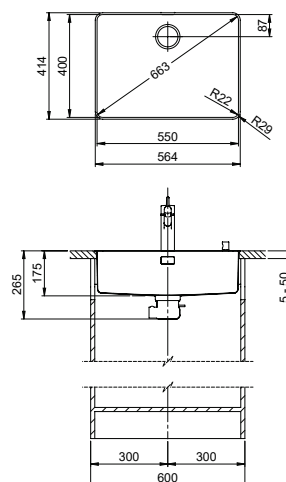
Randbreite 7 mm  
Larghezza bordo 7 mm



eFlow mit eControl  
eFlow con eControl

Schwenkbare Überlaufkappe  
Placchetta di troppopieno a ribalta

Desino: Verdeckter Ablauf mit untenliegendem Korb  
Desino: Scarico coperto con griglietta inferiore



Für eFlow Desino  
Per eFlow Desino

Für TouchFlow Desino, Raumspaar Desino und Typo Desino  
Per TouchFlow Desino, Salvaspazio Desino e Typo Desino



Für eFlow Desino, TouchFlow Desino, Raumspaar Desino und Typo Desino  
Per eFlow Desino, TouchFlow Desino, Salvaspazio Desino e Typo Desino

## Optionales Zubehör / Accessori opzionali

312



**Resteschale gelocht**  
**Vaschetta forata**  
CHF 106.– 40.000.912.00



**Resteschale ungelocht**  
**Vaschetta non forata**  
CHF 106.– 40.001.289.00



**Schneidebrett aus Glas**  
**Tagliere in vetro**  
CHF 151.– 40.000.909.00



**Schneidebrett aus Kunststoff**  
**Tagliere sintetico**  
CHF 151.– 40.001.277.00

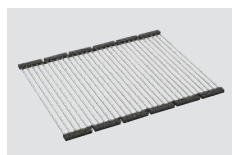

**Inox Pad**  
CHF 125.– 40.001.138.00

Zeichnung als pdf / dxf und Montageanleitung siehe:  
V. disegno in formato pdf / dxf e montaggio:  
suter.ch

**Nur für flächenbündigen Einbau erhältlich.**  
Disponibile solo per montaggio a filo top.

### Flächenbündiger Einbau: Empfehlung zur Wahl der Arbeitsplatte

Wir empfehlen den Einbau in Arbeitsplatten aus Keramik, Granit, Kunststein (z.B. Corian oder Varicor) oder Massivholz. Vom Einbau in beschichtete Spanplatten raten wir ab.

### Montaggio a filo top: Consiglio per la scelta del piano di lavoro

Consigliamo il montaggio nei piani di lavoro in ceramica, granito, pietra artificiale (per es. Corian o Varicor) oppure in legno massiccio. Sconsigliamo la posa in pannelli di truciolato rivestiti.

Varianten: Der Austausch von Zugknöpfen erfolgt mittels Variantencode. Mehr Infos siehe Seite 395.  
Varianti: La sostituzione di pomoli avviene mediante codice variante. Per maggiori informazioni, vedere pag. 395.

## Preis CHF/Prezzo in CHF

Modell Modello	Material Materiale	Ventil sFlow, Typ M Piletta sFlow, tipo M	Artikel-Nr. N. di articolo	Beckentiefe Profondità	Exkl. MWST IVA esclusa	Inkl. MWST IVA inclusa	VRG TRA		
<b>Daneo DAN 55F/7</b>	Edelstahl, matt Acciaio inox, opaco	18/10	3 1/2" eFlow Desino	10.104.678.00	175 mm	A	1869.–	2020.–	0.19
			3 1/2" TouchFlow Desino	10.104.659.00	175 mm	A	1754.–	1896.–	0.19
			3 1/2" Raumspaar Desino Salvaspazio Desino	10.104.660.00	175 mm	A	1544.–	1669.–	
			3 1/2" Typo Desino	10.105.728.00	175 mm	A	1544.–	1669.–	

## Daneo: DAN 55IF/12

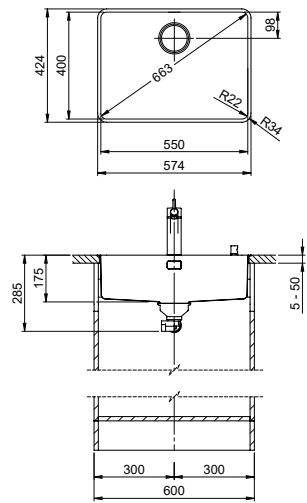
Randbreite 12 mm  
Larghezza bordo 12 mm
**Schwenkbare Überlaufkappe**  
Placchetta di troppieno a ribalta

15

**Obenliegendes Sieb**  
Griglietta superiore

14



Zeichnung als pdf / dxf und Montageanleitung siehe:  
V. disegno in formato pdf / dxf e montaggio:  
suter.ch

## Optionales Zubehör / Accessori opzionali

312

**Resteschale gelocht**  
**Vaschetta forata**  
CHF 106.– 40.000.912.00

**Resteschale ungelocht**  
**Vaschetta non forata**  
CHF 106.– 40.001.289.00

**Schneidebrett aus Glas**  
**Tagliere in vetro**  
CHF 151.– 40.000.909.00

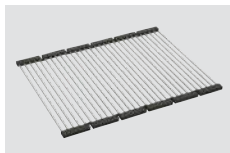
**Schneidebrett aus Kunststoff**  
**Tagliere sintetico**  
CHF 151.– 40.001.277.00

**Inox Pad**  
CHF 125.– 40.001.138.00

**Flächenbündiger Einbau: Empfehlung zur Wahl der Arbeitsplatte**

Wir empfehlen den Einbau in Arbeitsplatten aus Keramik, Granit, Kunststein (z.B. Corian oder Varicor) oder Massivholz. Vom Einbau in beschichtete Spanplatten raten wir ab.

**Montaggio a filo top: Consiglio per la scelta del piano di lavoro**

Consigliamo il montaggio nei piani di lavoro in ceramica, granito, pietra artificiale (per es. Corian o Varicor) oppure in legno massiccio. Sconsigliamo la posa in pannelli di truciolato rivestiti.

**1 Produktausführung, 2 Montagearten**

Der besondere Vorteil von IF-Modellen: Sowohl der flächenbündige Einbau als auch der flach aufliegende Einbau ist möglich.

**1 versione di prodotto, 2 metodi di montaggio**

I modelli IF presentano un grande vantaggio: possono essere posati sia a filo top che sopra piano.

**Varianten:** Der Austausch von Zugknöpfen erfolgt mittels Variantencode. Mehr Infos siehe Seite 395.  
**Varianti:** La sostituzione di pomoli avviene mediante codice variante. Per maggiori informazioni, vedere pag. 395.

Preis CHF / Prezzo in CHF

Modell Modello	Material Materiale	Ventil sFlow, Typ S Piletta sFlow, tipo S	Artikel-Nr. N. di articolo	Beckentiefe Profondità	Exkl. MWST IVA esclusa	Inkl. MWST IVA inclusa	VRG TRA		
<b>Daneo DAN 55IF/12</b>	Edelstahl, matt Acciaio inox, opaco	18 / 10	3 1/2" TouchFlow	10.104.212.00	175 mm	A	1394.–	1507.–	0.19
			3 1/2" Raumspar Salvaspazio	10.104.213.00	175 mm	A	1196.–	1293.–	
			3 1/2" Tipo	10.104.214.00	175 mm	A	1155.–	1249.–	

# Daneo: DAN 55IF/12

Randbreite 12 mm  
Larghezza bordo 12 mm

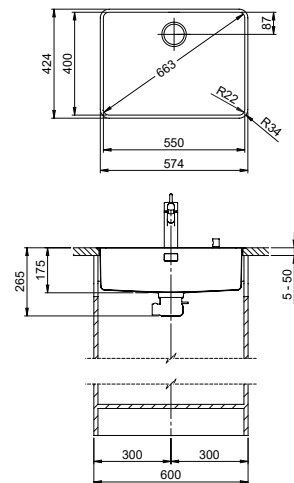

eFlow mit eControl  
eFlow con eControl

Schwenkbare Überlaufkappe  
Placchetta di troppopieno a ribalta

Desino: Verdeckter Ablauf mit untenliegendem Korb  
Desino: Scarico coperto con griglietta inferiore



Für eFlow Desino  
Per eFlow Desino

Für TouchFlow Desino, Raumspar Desino und Tipo Desino  
Per TouchFlow Desino, Salvaspazio Desino e Tipo Desino



Für eFlow Desino, TouchFlow Desino, Raumspar Desino und Tipo Desino  
Per eFlow Desino, TouchFlow Desino, Salvaspazio Desino e Tipo Desino

## Optionales Zubehör / Accessori opzionali



**Resteschale gelocht**  
Vaschetta forato  
CHF 106.– 40.000.912.00



**Resteschale ungelocht**  
Vaschetta non forato  
CHF 106.– 40.001.289.00



**Schneidebrett aus Glas**  
Tagliere in vetro  
CHF 151.– 40.000.909.00



**Schneidebrett aus Kunststoff**  
Tagliere sintetico  
CHF 151.– 40.001.277.00

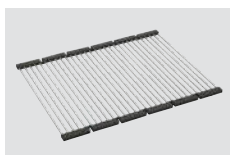

**Inox Pad**  
CHF 125.– 40.001.138.00

Zeichnung als pdf / dxf und Montageanleitung siehe:  
V. disegno in formato pdf / dxf e montaggio:  
suter.ch

**i Flächenbündiger Einbau: Empfehlung zur Wahl der Arbeitsplatte**  
Wir empfehlen den Einbau in Arbeitsplatten aus Keramik, Granit, Kunststein (z.B. Corian oder Varicor) oder Massivholz. Vom Einbau in beschichtete Spanplatten raten wir ab.  
**Montaggio a filo top: Consiglio per la scelta del piano di lavoro**  
Consigliamo il montaggio nei piani di lavoro in ceramica, granito, pietra artificiale (per es. Corian o Varicor) oppure in legno massiccio. Sconsigliamo la posa in pannelli di truciolato rivestiti.

**1 Produktausführung, 2 Montagearten**  
Der besondere Vorteil von IF-Modellen: Sowohl der flächenbündige Einbau als auch der flach aufliegende Einbau ist möglich.  
**1 versione di prodotto, 2 metodi di montaggio**  
I modelli IF presentano un grande vantaggio: possono essere posati sia a filo top che sopra piano.

**!** Varianten: Der Austausch von Zugknöpfen erfolgt mittels Variantencode. Mehr Infos siehe Seite 395.  
Varianti: La sostituzione di pomoli avviene mediante codice variante. Per maggiori informazioni, vedere pag. 395.

## Preis CHF / Prezzo in CHF

Modell Modello	Material Materiale	Ventil sFlow, Typ M Piletta sFlow, tipo M	Artikel-Nr. N. di articolo	Beckentiefe Profondità	Exkl. MWST IVA esclusa	Inkl. MWST IVA inclusa	VRG TRA		
<b>Daneo DAN 55IF/12</b>	Edelstahl, matt Acciaio inox, opaco	18/10	3 1/2" eFlow Desino	10.104.679.00	175 mm	A	1661.–	1796.–	0.19
			3 1/2" TouchFlow Desino	10.104.661.00	175 mm	A	1546.–	1671.–	0.19
			3 1/2" Raumspar Desino Salvaspazio Desino	10.104.662.00	175 mm	A	1336.–	1444.–	
			3 1/2" Tipo Desino	10.105.732.00	175 mm	A	1336.–	1444.–	

## Daneo: DAN 100-50IF

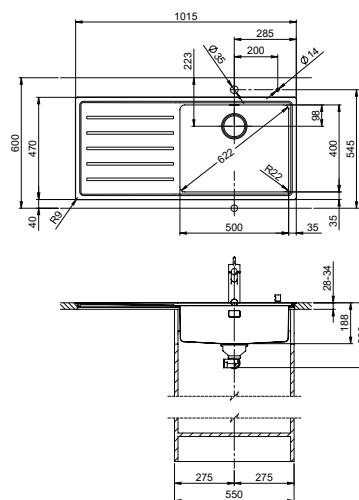

Schwenkbare Überlaufkappe  
Placchetta di troppopieno a ribalta

15

Obenliegendes Sieb  
Griglietta superiore

14



Zeichnung als pdf / dxf und Montageanleitung siehe:  
V. disegno in formato pdf / dxf e montaggio:  
suter.ch

## Optionales Zubehör / Accessori opzionali

312



**Resteschale** gelocht  
**Vaschetta** forato

CHF 106.– 40.000.912.00



**Resteschale** ungelocht  
**Vaschetta** non forato

CHF 106.– 40.001.289.00



**Schneidebrett** aus Glas  
**Tagliere** in vetro

CHF 151.– 40.000.909.00

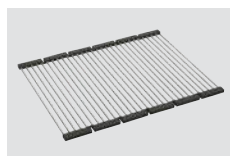

**Inox Pad**

CHF 125.– 40.001.140.00

**Flächenbündiger Einbau: Empfehlung zur Wahl der Arbeitsplatte**

Wir empfehlen den Einbau in Arbeitsplatten aus Keramik, Granit, Kunststein (z.B. Corian oder Varicor) oder Massivholz. Vom Einbau in beschichtete Spanplatten raten wir ab.

**Montaggio a filo top: Consiglio per la scelta del piano di lavoro**

Consigliamo il montaggio nei piani di lavoro in ceramica, granito, pietra artificiale (per es. Corian o Varicor) oppure in legno massiccio. Sconsigliamo la posa in pannelli di truciolato rivestiti.

**1 Produktausführung, 2 Montagearten**

Der besondere Vorteil von IF-Modellen: Sowohl der flächenbündige Einbau als auch der flach aufliegende Einbau ist möglich.

**1 versione di prodotto, 2 metodi di montaggio**

I modelli IF presentano un grande vantaggio: possono essere posati sia a filo top che sopra piano.

Varianten: Der Austausch von Zugknöpfen erfolgt mittels Variantencode. Mehr Infos siehe Seite 395.  
Varianti: La sostituzione di pomoli avviene mediante codice variante. Per maggiori informazioni, vedere pag. 395.

## Preis CHF / Prezzo in CHF

Modell Modello	Material Materiale	Ventil Piletta	Artikel-Nr. N. di articolo	Tropfteil Scolatoio	Exkl. MWST IVA esclusa	Inkl. MWST IVA inclusa	VRG TRA	
<b>Daneo DAN 100-50IF</b>	Edelstahl, matt Acciaio inox, opaco	3 1/2" TouchFlow	10.103.588.00	Links / Sinistra	A	2284.–	2469.–	0.19
			10.103.591.00	Rechts / Destra				
		3 1/2" Raumspar Salvaspazio	10.103.589.00	Links / Sinistra	A	2086.–	2255.–	
			10.103.592.00	Rechts / Destra				
		3 1/2" Tipo	10.103.590.00	Links / Sinistra	A	2045.–	2211.–	
			10.103.593.00	Rechts / Destra				

# Daneo: DAN 100-55IF

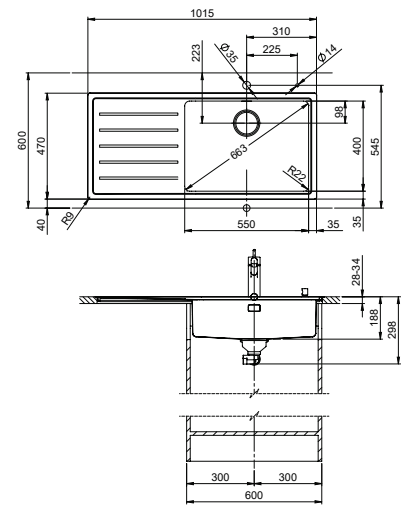

Schwenkbare Überlaufkappe  
Placchetta di troppopieno a ribalta

Obenliegendes Sieb  
Griglietta superiore



Zeichnung als pdf / dxf und Montageanleitung siehe:  
V. disegno in formato pdf / dxf e montaggio:  
suter.ch

## Optionales Zubehör / Accessori opzionali



**Resteschale gelocht**  
**Vaschetta forato**  
CHF 106.– 40.000.912.00

**Resteschale ungelocht**  
**Vaschetta non forato**  
CHF 106.– 40.001.289.00

**Schneidebrett aus Glas**  
**Tagliere in vetro**  
CHF 151.– 40.000.909.00

**Inox Pad**  
CHF 125.– 40.001.140.00

**Flächenbündiger Einbau: Empfehlung zur Wahl der Arbeitsplatte**  
Wir empfehlen den Einbau in Arbeitsplatten aus Keramik, Granit, Kunststein (z.B. Corian oder Varicor) oder Massivholz. Vom Einbau in beschichtete Spanplatten raten wir ab.

**Montaggio a filo top: Consiglio per la scelta del piano di lavoro**  
Consigliamo il montaggio nei piani di lavoro in ceramica, granito, pietra artificiale (per es. Corian o Varicor) oppure in legno massiccio. Sconsigliamo la posa in pannelli di truciolato rivestiti.

**1 Produktausführung, 2 Montagearten**  
Der besondere Vorteil von IF-Modellen: Sowohl der flächenbündige Einbau als auch der flach aufliegende Einbau ist möglich.

**1 versione di prodotto, 2 metodi di montaggio**  
I modelli IF presentano un grande vantaggio: possono essere posati sia a filo top che sopra piano.

Varianten: Der Austausch von Zugknöpfen erfolgt mittels Variantencode. Mehr Infos siehe Seite 395.  
Varianti: La sostituzione di pomoli avviene mediante codice variante. Per maggiori informazioni, vedere pag. 395.

## Preis CHF / Prezzo in CHF

Modell Modello	Material Materiale	Ventil Piletta	Artikel-Nr. N. di articolo	Tropfteil Scolatoio	Exkl. MWST IVA esclusa	Inkl. MWST IVA inclusa	VRG TRA
<b>Daneo DAN 100-55IF</b>	Edelstahl, matt Acciaio inox, opaco	3 1/2" TouchFlow	10.103.974.00	Links / Sinistra	A	2396.–	2590.–
			10.103.975.00	Rechts / Destra			
		3 1/2" Raumspar Salvaspazio	10.103.985.00	Links / Sinistra	A	2198.–	2376.–
			10.103.986.00	Rechts / Destra			
		3 1/2" Tipo	10.103.976.00	Links / Sinistra	A	2157.–	2332.–
			10.103.977.00	Rechts / Destra			

## Daneo: DAN 110-50IF

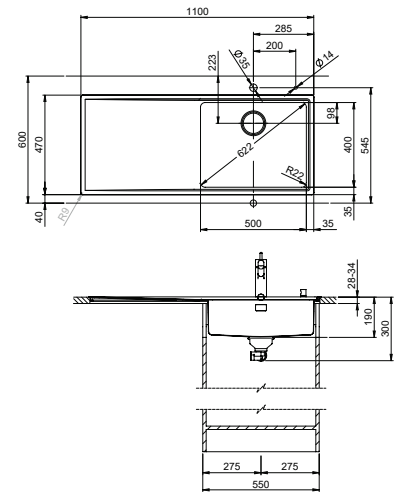

Schwenkbare Überlaufkappe  
Placchetta di troppopieno a ribalta



Obenliegendes Sieb  
Griglietta superiore



Zeichnung als pdf / dxf und Montageanleitung siehe:  
V. disegno in formato pdf / dxf e montaggio:  
suter.ch

## Optionales Zubehör / Accessori opzionali



Resteschale gelocht  
Vaschetta forato

CHF 106.– 40.000.912.00

Resteschale ungelocht  
Vaschetta non forato

CHF 106.– 40.001.289.00

Schneidebrett aus Glas  
Tagliere in vetro

CHF 151.– 40.000.909.00

Inox Pad

CHF 125.– 40.001.140.00

**Flächenbündiger Einbau: Empfehlung zur Wahl der Arbeitsplatte**

Wir empfehlen den Einbau in Arbeitsplatten aus Keramik, Granit, Kunststein (z.B. Corian oder Varicor) oder Massivholz. Vom Einbau in beschichtete Spanplatten raten wir ab.

**Montaggio a filo top: Consiglio per la scelta del piano di lavoro**

Consigliamo il montaggio nei piani di lavoro in ceramica, granito, pietra artificiale (per es. Corian o Varicor) oppure in legno massiccio. Sconsigliamo la posa in pannelli di truciolato rivestiti.

**1 Produktausführung, 2 Montagearten**

Der besondere Vorteil von IF-Modellen: Sowohl der flächenbündige Einbau als auch der flach aufliegende Einbau ist möglich.

**1 versione di prodotto, 2 metodi di montaggio**

I modelli IF presentano un grande vantaggio: possono essere posati sia a filo top che sopra piano.

**!** Varianten: Der Austausch von Zugknöpfen erfolgt mittels Variantencode. Mehr Infos siehe Seite 395.  
Varianti: La sostituzione di pomoli avviene mediante codice variante. Per maggiori informazioni, vedere pag. 395.

## Preis CHF / Prezzo in CHF

Modell Modello	Material Materiale	Ventil Piletta	Artikel-Nr. N. di articolo	Tropfteil Scolatoio	Exkl. MWST IVA esclusa	Inkl. MWST IVA inclusa	VRG TRA
Daneo DAN 110-50IF	Edelstahl, matt Acciaio inox, opaco	3 1/2" TouchFlow	10.103.962.00	Links / Sinistra	A	2356.–	2547.–
			10.103.963.00	Rechts / Destra			
		3 1/2" Raumspar Salvaspazio	10.103.981.00	Links / Sinistra	A	2158.–	2333.–
			10.103.982.00	Rechts / Destra			
		3 1/2" Tipo	10.103.964.00	Links / Sinistra	A	2117.–	2288.–
			10.103.965.00	Rechts / Destra			

# Daneo: DAN 40IF/A

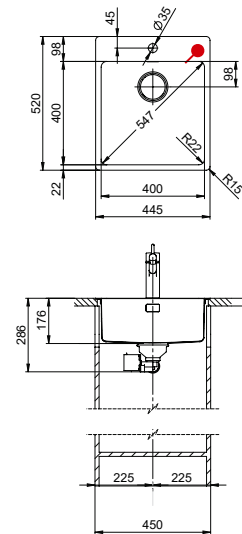
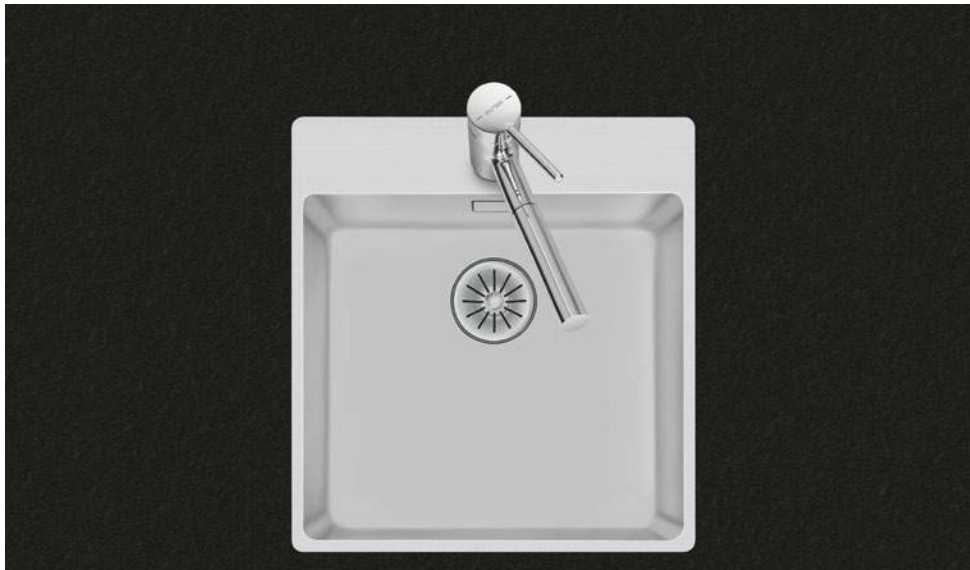

Schwenkbare Überlaufkappe  
Placchetta di troppopieno a ribalta

Obenliegendes Sieb  
Griglietta superiore

14



Zeichnung als pdf / dxf und Montageanleitung siehe:  
V. disegno in formato pdf / dxf e montaggio:  
suter.ch

## Optionales Zubehör / Accessori opzionali

312



**Resteschale gelocht**  
**Vaschetta forato**  
CHF 106.- 40.000.912.00



**Resteschale ungelocht**  
**Vaschetta non forato**  
CHF 106.- 40.001.289.00



**Schneidebrett aus Glas**  
**Tagliere in vetro**  
CHF 151.- 40.000.909.00



**Schneidebrett aus Kunststoff**  
**Tagliere sintetico**  
CHF 151.- 40.001.277.00

**Flächenbündiger Einbau: Empfehlung zur Wahl der Arbeitsplatte**  
Wir empfehlen den Einbau in Arbeitsplatten aus Keramik, Granit, Kunststein (z.B. Corian oder Varicor) oder Massivholz. Vom Einbau in beschichtete Spanplatten raten wir ab.

**Montaggio a filo top: Consiglio per la scelta del piano di lavoro**  
Consigliamo il montaggio nei piani di lavoro in ceramica, granito, pietra artificiale (per es. Corian o Varicor) oppure in legno massiccio. Sconsigliamo la posa in pannelli di truciolato rivestiti.

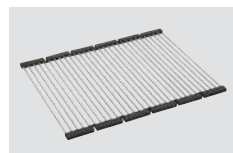

**Inox Pad**  
CHF 125.- 40.001.138.00

**1 Produktausführung, 2 Montagearten**  
Der besondere Vorteil von IF-Modellen: Sowohl der flächenbündige Einbau als auch der flach aufliegende Einbau ist möglich.  
 **1 versione di prodotto, 2 metodi di montaggio**  
I modelli IF presentano un grande vantaggio: possono essere posati sia a filo top che sopra piano.

### Preis CHF / Prezzo in CHF

Modell Modello	Material Materiale	Ventil Piletta	Artikel-Nr. N. di articolo	Beckentiefe Profondità	Exkl. MWST IVA esclusa	Inkl. MWST IVA inclusa	VRG TRA		
<b>Daneo DAN 40IF/A</b>	Edelstahl, matt Acciaio inox, opaco	18 / 10	3 1/2" TouchFlow	10.104.806.00	175 mm	A	1573.-	1700.-	0.19
			3 1/2" Tipo	10.104.807.00	175 mm	A	1334.-	1442.-	

## Daneo: DAN 50IF/A

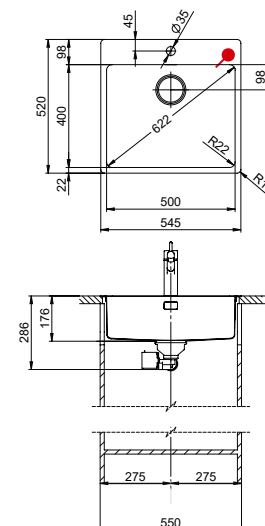

Schwenkbare Überlaufkappe  
Placchetta di troppieno a ribalta

15

Obenliegendes Sieb  
Griglietta superiore

14



Zeichnung als pdf / dxf und Montageanleitung siehe:  
V. disegno in formato pdf / dxf e montaggio:  
suter.ch

## Optionales Zubehör / Accessori opzionali

312



**Resteschale** gelocht  
**Vaschetta** forato

CHF 106.– 40.000.912.00



**Resteschale** ungelocht  
**Vaschetta** non forato

CHF 106.– 40.001.289.00



**Schneidebrett** aus Glas  
**Tagliere** in vetro

CHF 151.– 40.000.909.00



**Schneidebrett** aus Kunststoff  
**Tagliere** sintetico

CHF 151.– 40.001.277.00

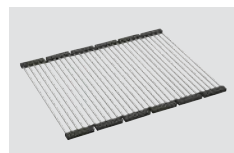

**Inox Pad**

CHF 125.– 40.001.138.00

**Flächenbündiger Einbau: Empfehlung zur Wahl der Arbeitsplatte**

Wir empfehlen den Einbau in Arbeitsplatten aus Keramik, Granit, Kunststein (z.B. Corian oder Varicor) oder Massivholz. Vom Einbau in beschichtete Spanplatten raten wir ab.

**Montaggio a filo top: Consiglio per la scelta del piano di lavoro**

Consigliamo il montaggio nei piani di lavoro in ceramica, granito, pietra artificiale (per es. Corian o Varicor) oppure in legno massiccio. Sconsigliamo la posa in pannelli di truciolato rivestiti.

**1 Produktausführung, 2 Montagearten**

Der besondere Vorteil von IF-Modellen: Sowohl der flächenbündige Einbau als auch der flach aufliegende Einbau ist möglich.

**1 versione di prodotto, 2 metodi di montaggio**

I modelli IF presentano un grande vantaggio: possono essere posati sia a filo top che sopra piano.

Preis CHF / Prezzo in CHF

Modell Modello	Material Materiale	Ventil Piletta	Artikel-Nr. N. di articolo	Beckentiefe Profondità	Exkl. MWST IVA esclusa	Inkl. MWST IVA inclusa	VRG TRA		
<b>Daneo DAN 50IF/A</b>	Edelstahl, matt Acciaio inox, opaco	18/10	3 1/2" TouchFlow	10.103.586.00	175 mm	A	1676.–	1812.–	0.19
			3 1/2" Tipo	10.103.587.00	175 mm	A	1437.–	1553.–	

# Daneo: DAN 55IF/A

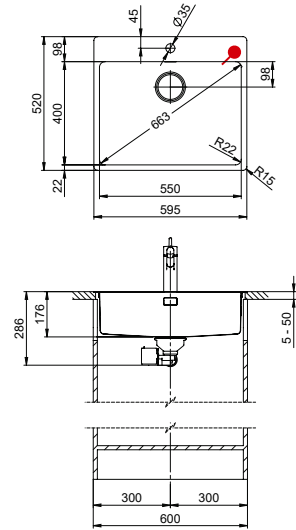
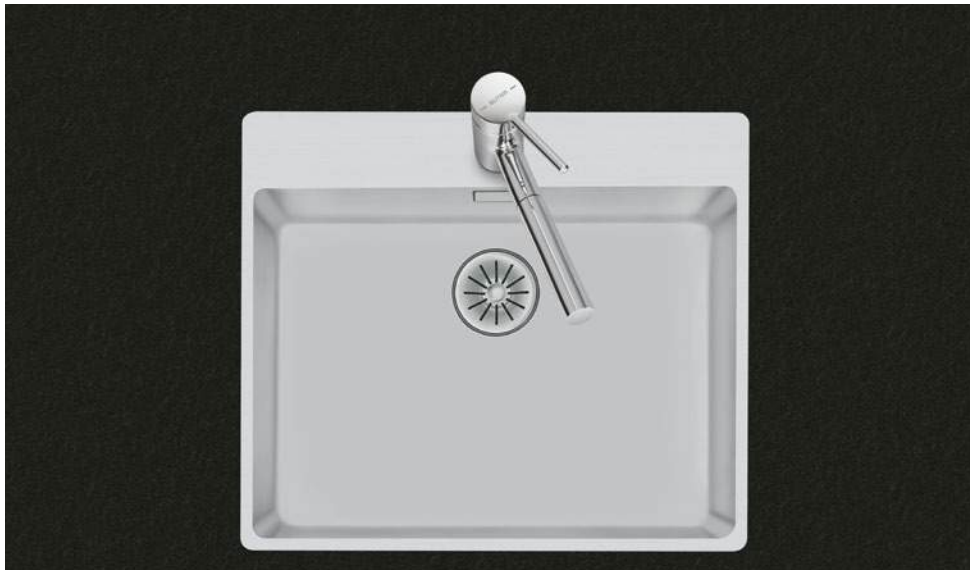

Schwenkbare Überlaufkappe  
Placchetta di troppieno a ribalta

Obenliegendes Sieb  
Griglietta superiore

14



Zeichnung als pdf / dxf und Montageanleitung siehe:  
V. disegno in formato pdf / dxf e montaggio:  
suter.ch

## Optionales Zubehör / Accessori opzionali

312



**Resteschale** gelocht  
**Vaschetta** forato  
CHF 106.– 40.000.912.00



**Resteschale** ungelocht  
**Vaschetta** non forato  
CHF 106.– 40.001.289.00



**Schneidebrett** aus Glas  
**Tagliere** in vetro  
CHF 151.– 40.000.909.00



**Schneidebrett** aus Kunststoff  
**Tagliere** sintetico  
CHF 151.– 40.001.277.00

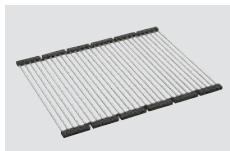

**Inox Pad**  
CHF 125.– 40.001.138.00

**Flächenbündiger Einbau: Empfehlung zur Wahl der Arbeitsplatte**  
Wir empfehlen den Einbau in Arbeitsplatten aus Keramik, Granit, Kunststein (z.B. Corian oder Varicor) oder Massivholz. Vom Einbau in beschichtete Spanplatten raten wir ab.

**Montaggio a filo top: Consiglio per la scelta del piano di lavoro**  
Consigliamo il montaggio nei piani di lavoro in ceramica, granito, pietra artificiale (per es. Corian o Varicor) oppure in legno massiccio. Sconsigliamo la posa in pannelli di truciolato rivestiti.

**1 Produktausführung, 2 Montagearten**  
Der besondere Vorteil von IF-Modellen: Sowohl der flächenbündige Einbau als auch der flach aufliegende Einbau ist möglich.

**1 versione di prodotto, 2 metodi di montaggio**  
I modelli IF presentano un grande vantaggio: possono essere posati sia a filo top che sopra piano.

## Preis CHF / Prezzo in CHF

Modell Modello	Material Materiale	Ventil Piletta	Artikel-Nr. N. di articolo	Beckentiefe Profondità	Exkl. MWST IVA esclusa	Inkl. MWST IVA inclusa	VRG TRA		
<b>Daneo</b> <b>DAN 55IF/A</b>	Edelstahl, matt Acciaio inox, opaco	18 / 10	3 1/2" TouchFlow	10.104.808.00	175 mm	A	1780.–	1924.–	0.19
			3 1/2" Tipo	10.104.809.00	175 mm	A	1541.–	1666.–	

## Daneo: DAN 100-50IF/A

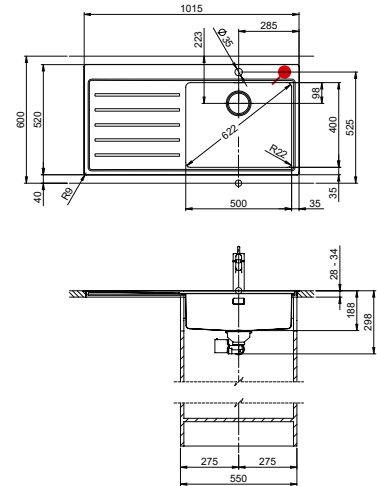

Schwenkbare Überlaufkappe  
Placchetta di troppopieno a ribalta

15

Obenliegendes Sieb  
Griglietta superiore

14



Zeichnung als pdf / dxf und Montageanleitung siehe:  
V. disegno in formato pdf / dxf e montaggio:  
suter.ch

## Optionales Zubehör / Accessori opzionali

312



**Resteschale** gelocht  
**Vaschetta** forato

CHF 106.– 40.000.912.00



**Resteschale** ungelocht  
**Vaschetta** non forato

CHF 106.– 40.001.289.00



**Schneidebrett** aus Glas  
**Tagliere** in vetro

CHF 151.– 40.000.909.00

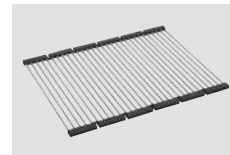

**Inox Pad**

CHF 125.– 40.001.140.00

**Flächenbündiger Einbau: Empfehlung zur Wahl der Arbeitsplatte**

Wir empfehlen den Einbau in Arbeitsplatten aus Keramik, Granit, Kunststein (z.B. Corian oder Varicor) oder Massivholz. Vom Einbau in beschichtete Spanplatten raten wir ab.

**Montaggio a filo top: Consiglio per la scelta del piano di lavoro**

Consigliamo il montaggio nei piani di lavoro in ceramica, granito, pietra artificiale (per es. Corian o Varicor) oppure in legno massiccio. Sconsigliamo la posa in pannelli di truciolato rivestiti.

**1 Produktausführung, 2 Montagearten**

Der besondere Vorteil von IF-Modellen: Sowohl der flächenbündige Einbau als auch der flach aufliegende Einbau ist möglich.

**1 versione di prodotto, 2 metodi di montaggio**

I modelli IF presentano un grande vantaggio: possono essere posati sia a filo top che sopra piano.

## Preis CHF / Prezzo in CHF

Modell Modello	Material Materiale	Ventil Piletta	Artikel-Nr. N. di articolo	Tropfteil Scolatoio	Exkl. MWST IVA esclusa	Inkl. MWST IVA inclusa	VRG TRA
<b>Daneo DAN 100-50IF/A</b>	Edelstahl, matt Acciaio inox, opaco 18/10	3 ½" TouchFlow	10.103.550.00	Links / Sinistra	A	2483.–	2684.–
			10.103.553.00	Rechts / Destra			
		3 ½" Tipo	10.103.551.00	Links / Sinistra	A	2244.–	2426.–
			10.103.552.00	Rechts / Destra			

Daneo: DAN 100-55IF/A

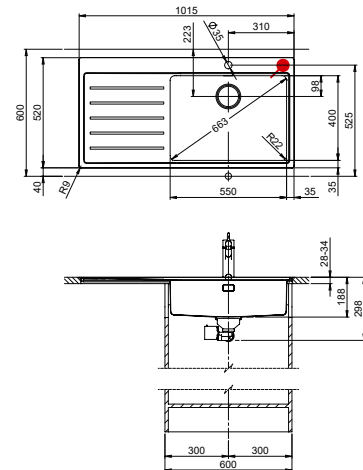
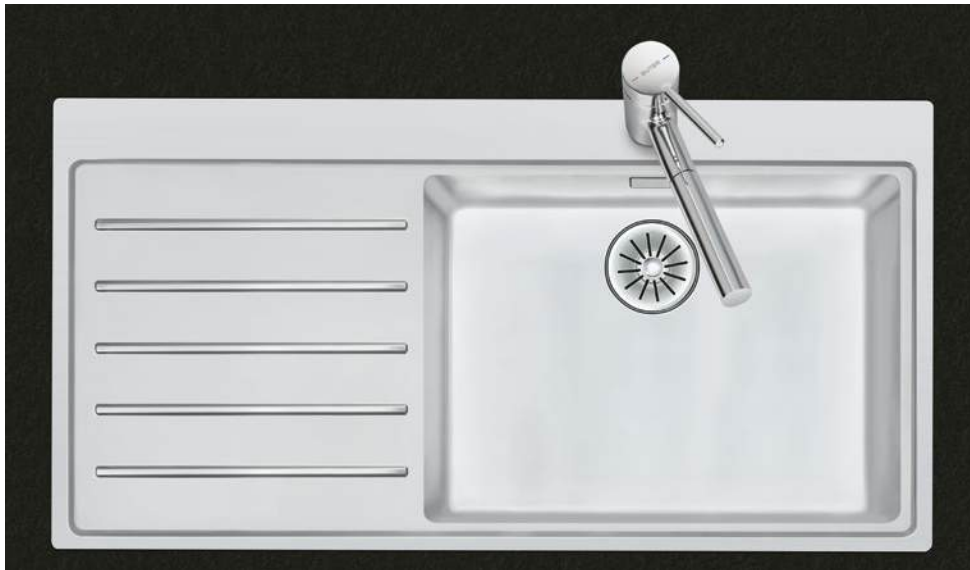

Schwenkbare Überlaufkappe  
Placchetta di troppopieno a ribalta

Obenliegendes Sieb  
Griglietta superiore

14



Zeichnung als pdf / dxf und Montageanleitung siehe:  
V. disegno in formato pdf / dxf e montaggio:  
suter.ch

Optionales Zubehör / Accessori opzionali

312



**Resteschale gelocht**  
**Vaschetta forato**  
CHF 106.– 40.000.912.00



**Resteschale ungelocht**  
**Vaschetta non forato**  
CHF 106.– 40.001.289.00



**Schneidebrett aus Glas**  
**Tagliere in vetro**  
CHF 151.– 40.000.909.00

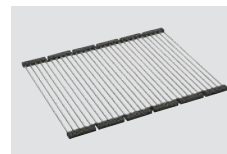

**Inox Pad**  
CHF 125.– 40.001.140.00

**Flächenbündiger Einbau: Empfehlung zur Wahl der Arbeitsplatte**  
Wir empfehlen den Einbau in Arbeitsplatten aus Keramik, Granit, Kunststein (z.B. Corian oder Varicor) oder Massivholz. Vom Einbau in beschichtete Spanplatten raten wir ab.

**Montaggio a filo top: Consiglio per la scelta del piano di lavoro**  
Consigliamo il montaggio nei piani di lavoro in ceramica, granito, pietra artificiale (per es. Corian o Varicor) oppure in legno massiccio. Sconsigliamo la posa in pannelli di truciolato rivestiti.

**1 Produktausführung, 2 Montagearten**  
Der besondere Vorteil von IF-Modellen: Sowohl der flächenbündige Einbau als auch der flach aufliegende Einbau ist möglich.

**1 versione di prodotto, 2 metodi di montaggio**  
I modelli IF presentano un grande vantaggio: possono essere posati sia a filo top che sopra piano.

Preis CHF / Prezzo in CHF

Modell Modello	Material Materiale	Ventil Piletta	Artikel-Nr. N. di articolo	Tropfteil Scolatoio	Exkl. MWST IVA esclusa	Inkl. MWST IVA inclusa	VRG TRA
<b>Daneo DAN 100-55IF/A</b>	Edelstahl, matt Acciaio inox, opaco 18/10	3 1/2" TouchFlow	10.103.970.00	Links / Sinistra	A 2599.–	2810.–	0.19
			10.103.971.00	Rechts / Destra			
		3 1/2" Tipo	10.103.972.00	Links / Sinistra	A 2360.–	2551.–	
			10.103.973.00	Rechts / Destra			

## Daneo: DAN 110-50IF/A

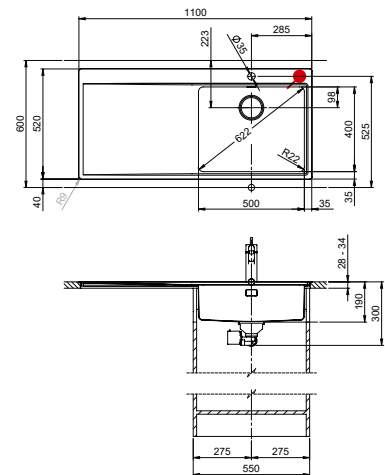

Schwenkbare Überlaufkappe  
Placchetta di troppopieno a ribalta

15

Obenliegendes Sieb  
Griglietta superiore

14



Zeichnung als pdf / dxf und Montageanleitung siehe:  
V. disegno in formato pdf / dxf e montaggio:  
suter.ch

## Optionales Zubehör / Accessori opzionali

312



**Resteschale** gelocht  
**Vaschetta forato**

CHF 106.– 40.000.912.00

**Resteschale** ungelocht  
**Vaschetta non forato**

CHF 106.– 40.001.289.00

**Schneidebrett** aus Glas  
**Tagliere in vetro**

CHF 151.– 40.000.909.00

**Inox Pad**

CHF 125.– 40.001.140.00

**Flächenbündiger Einbau: Empfehlung zur Wahl der Arbeitsplatte**

Wir empfehlen den Einbau in Arbeitsplatten aus Keramik, Granit, Kunststein (z.B. Corian oder Varicor) oder Massivholz. Vom Einbau in beschichtete Spanplatten raten wir ab.

**Montaggio a filo top: Consiglio per la scelta del piano di lavoro**

Consigliamo il montaggio nei piani di lavoro in ceramica, granito, pietra artificiale (per es. Corian o Varicor) oppure in legno massiccio. Sconsigliamo la posa in pannelli di truciolato rivestiti.

**1 Produktausführung, 2 Montagearten**

Der besondere Vorteil von IF-Modellen: Sowohl der flächenbündige Einbau als auch der flach aufliegende Einbau ist möglich.

**1 versione di prodotto, 2 metodi di montaggio**

I modelli IF presentano un grande vantaggio: possono essere posati sia a filo top che sopra piano.

## Preis CHF / Prezzo in CHF

Modell Modello	Material Materiale	Ventil Piletta	Artikel-Nr. N. di articolo	Tropfteil Scolatoio	Exkl. MWST IVA esclusa	Inkl. MWST IVA inclusa	VRG TRA
<b>Daneo DAN 110-50IF/A</b>	Edelstahl, matt Acciaio inox, opaco 18/10	3 1/2" TouchFlow	10.103.798.00	Links / Sinistra	A 2546.–	2752.–	0.19
			10.103.799.00	Rechts / Destra			
		3 1/2" Tipo	10.103.800.00	Links / Sinistra	A 2307.–	2494.–	
			10.103.801.00	Rechts / Destra			

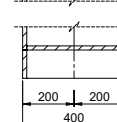
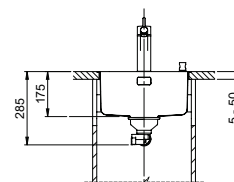
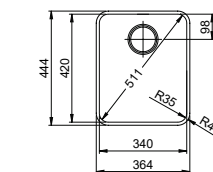

## Vantis: V 34IF/12

Randbreite 12 mm  
Larghezza bordo 12 mm

 Schwenkbare Überlaufkappe  
Placchetta di troppopieno a ribalta

15

 Obenliegendes Sieb  
Griglietta superiore

14

 Zeichnung als pdf / dxf und Montageanleitung siehe:  
V. disegno in formato pdf / dxf e montaggio:  
suter.ch

## Optionales Zubehör / Accessori opzionali

312

**Resteschale gelocht**  
**Vaschetta forato**  
CHF 106.– 40.000.914.00

**Resteschale ungelocht**  
**Vaschetta non forato**  
CHF 106.– 40.001.290.00

**Schneidebrett aus Glas**  
**Tagliere in vetro**  
CHF 151.– 40.000.915.00

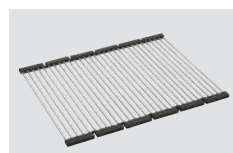
**Holz-Schneidebrett aus Nussbaum**  
**Tagliere in legno di noce**  
CHF 151.– 40.001.147.00

**Inox Pad**  
CHF 125.– 40.001.138.00

**Flächenbündiger Einbau: Empfehlung zur Wahl der Arbeitsplatte**

Wir empfehlen den Einbau in Arbeitsplatten aus Keramik, Granit, Kunststein (z.B. Corian oder Varicor) oder Massivholz. Vom Einbau in beschichtete Spanplatten raten wir ab.

**Montaggio a filo top: Consiglio per la scelta del piano di lavoro**

Consigliamo il montaggio nei piani di lavoro in ceramica, granito, pietra artificiale (per es. Corian o Varicor) oppure in legno massiccio. Sconsigliamo la posa in pannelli di truciolato rivestiti.

**1 Produktausführung, 2 Montagearten**

Der besondere Vorteil von IF-Modellen: Sowohl der flächenbündige Einbau als auch der flach aufliegende Einbau ist möglich.

**1 versione di prodotto, 2 metodi di montaggio**

I modelli IF presentano un grande vantaggio: possono essere posati sia a filo top che sopra piano.

 Varianten: Der Austausch von Zugknöpfen erfolgt mittels Variantencode. Mehr Infos siehe Seite 395.  
Varianti: La sostituzione di pomoli avviene mediante codice variante. Per maggiori informazioni, vedere pag. 395.

Preis CHF / Prezzo in CHF

Modell Modello	Material Materiale	Ventil sFlow, Typ S Piletta sFlow, tipo S	Artikel-Nr. N. di articolo	Beckentiefe Profondità	Exkl. MWST IVA esclusa	Inkl. MWST IVA inclusa	VRG TRA		
Vantis V 34IF/12	Edelstahl, matt Acciaio inox, opaco	18 / 10	3 1/2" TouchFlow	10.104.218.00	175 mm	A	1040.–	1124.–	0.19
			3 1/2" Raumspar Salvaspazio	10.104.219.00	175 mm	A	842.–	910.–	
			3 1/2" Tipo	10.104.220.00	175 mm	A	793.–	857.–	

# Vantis: V 34IF/12

Randbreite 12 mm  
Larghezza bordo 12 mm

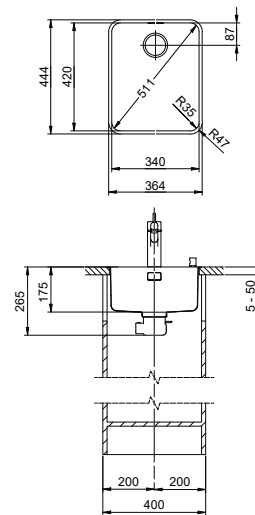

eFlow mit eControl  
eFlow con eControl

Schwenkbare Überlaufkappe  
Placchetta di troppopieno a ribalta

Desino: Verdeckter Ablauf mit untenliegendem Korb  
Desino: Scarico coperto con griglietta inferiore



Für eFlow Desino  
Per eFlow Desino

Für TouchFlow Desino, Raumspaar Desino und Tipo Desino  
Per TouchFlow Desino, Salvaspazio Desino e Tipo Desino

Für eFlow Desino, TouchFlow Desino, Raumspaar Desino und Tipo Desino  
Per eFlow Desino, TouchFlow Desino, Salvaspazio Desino e Tipo Desino

## Optionales Zubehör / Accessori opzionali



**Resteschale gelocht**  
**Vaschetta forato**  
CHF 106.– 40.000.914.00



**Resteschale ungelocht**  
**Vaschetta non forato**  
CHF 106.– 40.001.290.00



**Schneidebrett aus Glas**  
**Tagliere in vetro**  
CHF 151.– 40.000.915.00



**Holz-Schneidebrett aus Nussbaum**  
**Tagliere in legno di noce**  
CHF 151.– 40.001.147.00

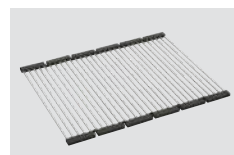

**Inox Pad**  
CHF 125.– 40.001.138.00

Zeichnung als pdf / dxf und Montageanleitung siehe:  
V. disegno in formato pdf / dxf e montaggio:  
suter.ch

**i Flächenbündiger Einbau: Empfehlung zur Wahl der Arbeitsplatte**  
Wir empfehlen den Einbau in Arbeitsplatten aus Keramik, Granit, Kunststein (z.B. Corian oder Varicor) oder Massivholz. Vom Einbau in beschichtete Spanplatten raten wir ab.  
**Montaggio a filo top: Consiglio per la scelta del piano di lavoro**  
Consigliamo il montaggio nei piani di lavoro in ceramica, granito, pietra artificiale (per es. Corian o Varicor) oppure in legno massiccio. Sconsigliamo la posa in pannelli di truciolato rivestiti.

**1 Produktausführung, 2 Montagearten**  
Der besondere Vorteil von IF-Modellen: Sowohl der flächenbündige Einbau als auch der flach aufliegende Einbau ist möglich.  
**1 versione di prodotto, 2 metodi di montaggio**  
I modelli IF presentano un grande vantaggio: possono essere posati sia a filo top che sopra piano.

**!** Varianten: Der Austausch von Zugknöpfen erfolgt mittels Variantencode. Mehr Infos siehe Seite 395.  
Varianti: La sostituzione di pomoli avviene mediante codice variante. Per maggiori informazioni, vedere pag. 395.

## Preis CHF / Prezzo in CHF

Modell Modello	Material Materiale	Ventil sFlow, Typ M Piletta sFlow, tipo M	Artikel-Nr. N. di articolo	Beckentiefe Profondità	Exkl. MWST IVA esclusa	Inkl. MWST IVA inclusa	VRG TRA	
<b>Vantis V 34IF/12</b>	Edelstahl, matt Acciaio inox, opaco	18/10	3 1/2" eFlow Desino	10.105.270.00	175 mm	A 1307.–	1413.–	0.19
			3 1/2" TouchFlow Desino	10.105.271.00	175 mm	A 1192.–	1289.–	0.19
			3 1/2" Raumspaar Desino Salvaspazio Desino	10.105.272.00	175 mm	A 982.–	1062.–	
			3 1/2" Tipo Desino	10.105.737.00	175 mm	A 982.–	1062.–	

## Vantis: V 40IF/12

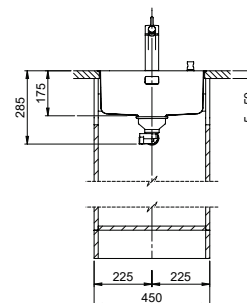
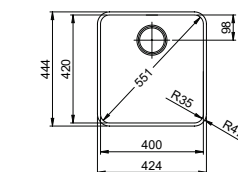
Randbreite 12 mm  
Larghezza bordo 12 mm

 Schwenkbare Überlaufkappe  
Placchetta di troppopieno a ribalta

15

 Obenliegendes Sieb  
Griglietta superiore

14

 Zeichnung als pdf / dxf und Montageanleitung siehe:  
V. disegno in formato pdf / dxf e montaggio:  
suter.ch

## Optionales Zubehör / Accessori opzionali

312

**Resteschale gelocht**  
**Vaschetta forato**  
CHF 106.– 40.000.914.00

**Resteschale ungelocht**  
**Vaschetta non forato**  
CHF 106.– 40.001.290.00

**Schneidebrett aus Glas**  
**Tagliere in vetro**  
CHF 151.– 40.000.915.00

**Holz-Schneidebrett aus Nussbaum**  
**Tagliere in legno di noce**  
CHF 151.– 40.001.147.00
**Flächenbündiger Einbau: Empfehlung zur Wahl der Arbeitsplatte**

Wir empfehlen den Einbau in Arbeitsplatten aus Keramik, Granit, Kunststein (z.B. Corian oder Varicor) oder Massivholz. Vom Einbau in beschichtete Spanplatten raten wir ab.

**Montaggio a filo top: Consiglio per la scelta del piano di lavoro**

Consigliamo il montaggio nei piani di lavoro in ceramica, granito, pietra artificiale (per es. Corian o Varicor) oppure in legno massiccio. Sconsigliamo la posa in pannelli di truciolato rivestiti.

**1 Produktausführung, 2 Montagearten**

Der besondere Vorteil von IF-Modellen: Sowohl der flächenbündige Einbau als auch der flach aufliegende Einbau ist möglich.

**1 versione di prodotto, 2 metodi di montaggio**

I modelli IF presentano un grande vantaggio: possono essere posati sia a filo top che sopra piano.

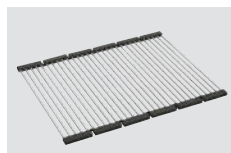
**Inox Pad**  
CHF 125.– 40.001.138.00



 Varianten: Der Austausch von Zugknöpfen erfolgt mittels Variantencode. Mehr Infos siehe Seite 395.  
Varianti: La sostituzione di pomoli avviene mediante codice variante. Per maggiori informazioni, vedere pag.395.

Preis CHF / Prezzo in CHF

Modell Modello	Material Materiale	Ventil sFlow, Typ S Piletta sFlow, tipo S	Artikel-Nr. N. di articolo	Beckentiefe Profondità	Exkl. MWST IVA esclusa	Inkl. MWST IVA inclusa	VRG TRA		
Vantis V 40IF/12	Edelstahl, matt Acciaio inox, opaco	18 / 10	3 1/2" TouchFlow	10.104.224.00	175 mm	A	1066.–	1152.–	0.19
			3 1/2" Raumspär Salvaspazio	10.104.225.00	175 mm	A	868.–	938.–	
			3 1/2" Tipo	10.104.226.00	175 mm	A	819.–	885.–	

# Vantis: V 40IF/12

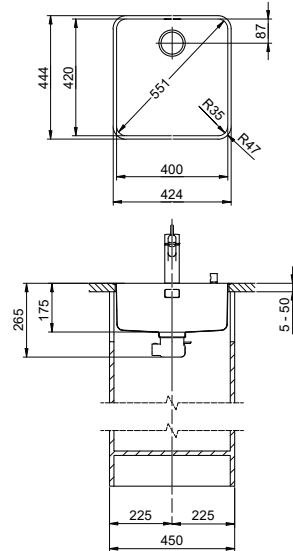
Randbreite 12 mm  
Larghezza bordo 12 mm



eFlow mit eControl  
eFlow con eControl

Schwenkbare Überlaufkappe  
Placchetta di troppopieno a ribalta

Desino: Verdeckter Ablauf mit untenliegendem Korb  
Desino: Scarico coperto con griglietta inferiore



Für eFlow Desino  
Per eFlow Desino

Für TouchFlow Desino, Raumspaar Desino und Tipo Desino  
Per TouchFlow Desino, Salvaspazio Desino e Tipo Desino

Für eFlow Desino, TouchFlow Desino, Raumspaar Desino und Tipo Desino  
Per eFlow Desino, TouchFlow Desino, Salvaspazio Desino e Tipo Desino

## Optionales Zubehör / Accessori opzionali



**Resteschale gelocht**  
**Vaschetta forato**  
CHF 106.– 40.000.914.00



**Resteschale ungelocht**  
**Vaschetta non forato**  
CHF 106.– 40.001.290.00



**Schneidebrett aus Glas**  
**Tagliere in vetro**  
CHF 151.– 40.000.915.00



**Holz-Schneidebrett aus Nussbaum**  
**Tagliere in legno di noce**  
CHF 151.– 40.001.147.00

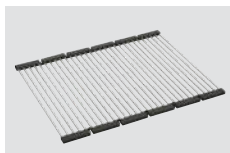

**Inox Pad**  
CHF 125.– 40.001.138.00

Zeichnung als pdf / dxf und Montageanleitung siehe:  
V. disegno in formato pdf / dxf e montaggio:  
suter.ch

**Flächenbündiger Einbau: Empfehlung zur Wahl der Arbeitsplatte**  
Wir empfehlen den Einbau in Arbeitsplatten aus Keramik, Granit, Kunststein (z.B. Corian oder Varicor) oder Massivholz. Vom Einbau in beschichtete Spanplatten raten wir ab.  
**Montaggio a filo top: Consiglio per la scelta del piano di lavoro**  
Consigliamo il montaggio nei piani di lavoro in ceramica, granito, pietra artificiale (per es. Corian o Varicor) oppure in legno massiccio. Sconsigliamo la posa in pannelli di truciolato rivestiti.

**1 Produktausführung, 2 Montagearten**  
Der besondere Vorteil von IF-Modellen: Sowohl der flächenbündige Einbau als auch der flach aufliegende Einbau ist möglich.  
**1 versione di prodotto, 2 metodi di montaggio**  
I modelli IF presentano un grande vantaggio: possono essere posati sia a filo top che sopra piano.

**!** Varianten: Der Austausch von Zugknöpfen erfolgt mittels Variantencode. Mehr Infos siehe Seite 395.  
Varianti: La sostituzione di pomoli avviene mediante codice variante. Per maggiori informazioni, vedere pag. 395.

## Preis CHF / Prezzo in CHF

Modell Modello	Material Materiale	Ventil sFlow, Typ M Piletta sFlow, tipo M	Artikel-Nr. N. di articolo	Beckentiefe Profondità	Exkl. MWST IVA esclusa	Inkl. MWST IVA inclusa	VRG TRA		
<b>Vantis V 40IF/12</b>	Edelstahl, matt Acciaio inox, opaco	18/10	3 1/2" eFlow Desino	10.105.273.00	175 mm	A	1333.–	1441.–	0.19
			3 1/2" TouchFlow Desino	10.105.274.00	175 mm	A	1218.–	1317.–	0.19
			3 1/2" Raumspaar Desino Salvaspazio Desino	10.105.275.00	175 mm	A	1008.–	1090.–	
			3 1/2" Tipo Desino	10.105.741.00	175 mm	A	1008.–	1090.–	

## Vantis: V 45IF/12

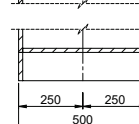
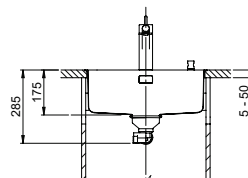
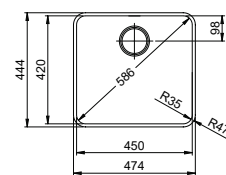
Randbreite 12 mm  
Larghezza bordo 12 mm

 Schwenkbare Überlaufkappe  
Placchetta di troppopieno a ribalta

15

 Obenliegendes Sieb  
Griglietta superiore

14



Zeichnung als pdf / dxf und Montageanleitung siehe:  
V. disegno in formato pdf / dxf e montaggio:  
suter.ch

## Optionales Zubehör / Accessori opzionali

312

**Resteschale gelocht**  
**Vaschetta forato**  
CHF 106.– 40.000.914.00

**Resteschale ungelocht**  
**Vaschetta non forato**  
CHF 106.– 40.001.290.00

**Schneidebrett aus Glas**  
**Tagliere in vetro**  
CHF 151.– 40.000.915.00

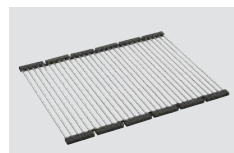
**Holz-Schneidebrett aus Nussbaum**  
**Tagliere in legno di noce**  
CHF 151.– 40.001.147.00

**Inox Pad**  
CHF 125.– 40.001.138.00
**Flächenbündiger Einbau: Empfehlung zur Wahl der Arbeitsplatte**

Wir empfehlen den Einbau in Arbeitsplatten aus Keramik, Granit, Kunststein (z.B. Corian oder Varicor) oder Massivholz. Vom Einbau in beschichtete Spanplatten raten wir ab.

**Montaggio a filo top: Consiglio per la scelta del piano di lavoro**

Consigliamo il montaggio nei piani di lavoro in ceramica, granito, pietra artificiale (per es. Corian o Varicor) oppure in legno massiccio. Sconsigliamo la posa in pannelli di truciolato rivestiti.

**1 Produktausführung, 2 Montagearten**

Der besondere Vorteil von IF-Modellen: Sowohl der flächenbündige Einbau als auch der flach aufliegende Einbau ist möglich.

**1 versione di prodotto, 2 metodi di montaggio**

I modelli IF presentano un grande vantaggio: possono essere posati sia a filo top che sopra piano.

Varianten: Der Austausch von Zugknöpfen erfolgt mittels Variantencode. Mehr Infos siehe Seite 395.  
Varianti: La sostituzione di pomoli avviene mediante codice variante. Per maggiori informazioni, vedere pag.395.

Preis CHF / Prezzo in CHF

Modell Modello	Material Materiale	Ventil sFlow, Typ S Piletta sFlow, tipo S	Artikel-Nr. N. di articolo	Beckentiefe Profondità	Exkl. MWST IVA esclusa	Inkl. MWST IVA inclusa	VRG TRA		
Vantis V 45IF/12	Edelstahl, matt Acciaio inox, opaco	18 / 10	3 1/2" TouchFlow	10.104.230.00	175 mm	A	1068.–	1155.–	0.19
			3 1/2" Raumspar Salvaspazio	10.104.231.00	175 mm	A	870.–	940.–	
			3 1/2" Tipo	10.104.232.00	175 mm	A	821.–	888.–	

# Vantis: V 45IF/12

Randbreite 12 mm  
Larghezza bordo 12 mm

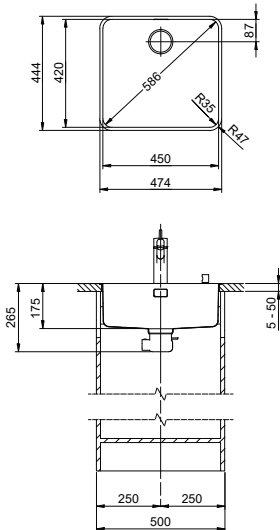

eFlow mit eControl  
eFlow con eControl

Schwenkbare Überlaufkappe  
Placchetta di troppopieno a ribalta

Desino: Verdeckter Ablauf mit untenliegendem Korb  
Desino: Scarico coperto con griglietta inferiore



Für eFlow Desino  
Per eFlow Desino

Für TouchFlow Desino, Raumspaar Desino und Tipo Desino  
Per TouchFlow Desino, Salvaspazio Desino e Tipo Desino

Für eFlow Desino, TouchFlow Desino, Raumspaar Desino und Tipo Desino  
Per eFlow Desino, TouchFlow Desino, Salvaspazio Desino e Tipo Desino

## Optionales Zubehör / Accessori opzionali



**Resteschale gelocht**  
Vaschetta forato

CHF 106.- 40.000.914.00



**Resteschale ungelocht**  
Vaschetta non forato

CHF 106.- 40.001.290.00



**Schneidebrett aus Glas**  
Tagliere in vetro

CHF 151.- 40.000.915.00



**Holz-Schneidebrett aus Nussbaum**  
Tagliere in legno di noce

CHF 151.- 40.001.147.00

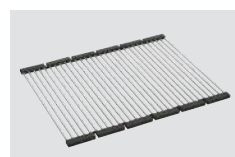

**Inox Pad**

CHF 125.- 40.001.138.00

Zeichnung als pdf / dxf und Montageanleitung siehe:  
V. disegno in formato pdf / dxf e montaggio:  
suter.ch

### Flächenbündiger Einbau: Empfehlung zur Wahl der Arbeitsplatte

Wir empfehlen den Einbau in Arbeitsplatten aus Keramik, Granit, Kunststein (z.B. Corian oder Varicor) oder Massivholz. Vom Einbau in beschichtete Spanplatten raten wir ab.

### Montaggio a filo top: Consiglio per la scelta del piano di lavoro

Consigliamo il montaggio nei piani di lavoro in ceramica, granito, pietra artificiale (per es. Corian o Varicor) oppure in legno massiccio. Sconsigliamo la posa in pannelli di truciolato rivestiti.

### 1 Produktausführung, 2 Montagearten

Der besondere Vorteil von IF-Modellen: Sowohl der flächenbündige Einbau als auch der flach aufliegende Einbau ist möglich.

### 1 versione di prodotto, 2 metodi di montaggio

I modelli IF presentano un grande vantaggio: possono essere posati sia a filo top che sopra piano.

Varianten: Der Austausch von Zugknöpfen erfolgt mittels Variantencode. Mehr Infos siehe Seite 395.  
Varianti: La sostituzione di pomoli avviene mediante codice variante. Per maggiori informazioni, vedere pag. 395.

## Preis CHF / Prezzo in CHF

Modell Modello	Material Materiale	Ventil sFlow, Typ M Piletta sFlow, tipo M	Artikel-Nr. N. di articolo	Beckentiefe Profondità	Exkl. MWST IVA esclusa	Inkl. MWST IVA inclusa	VRG TRA		
Vantis V 45IF/12	Edelstahl, matt Acciaio inox, opaco	18/10	3 1/2" eFlow Desino	10.105.279.00	175 mm	A	1335.-	1443.-	0.19
			3 1/2" TouchFlow Desino	10.105.210.00	175 mm	A	1220.-	1319.-	0.19
			3 1/2" Raumspaar Desino Salvaspazio Desino	10.105.211.00	175 mm	A	1010.-	1092.-	
			3 1/2" Tipo Desino	10.105.745.00	175 mm	A	1010.-	1092.-	

## Vantis: V 50-42IF/12

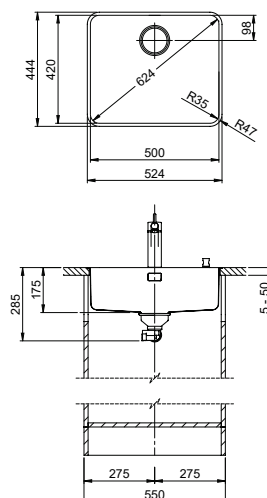
Randbreite 12 mm  
Larghezza bordo 12 mm

 Schwenkbare Überlaufkappe  
Placchetta di troppopieno a ribalta

15

 Obenliegendes Sieb  
Griglietta superiore

14

 Zeichnung als pdf / dxf und Montageanleitung siehe:  
V. disegno in formato pdf / dxf e montaggio:  
suter.ch

## Optionales Zubehör / Accessori opzionali

312

**Resteschale gelocht**  
**Vaschetta forato**  
CHF 106.– 40.000.914.00

**Resteschale ungelocht**  
**Vaschetta non forato**  
CHF 106.– 40.001.290.00

**Schneidebrett aus Glas**  
**Tagliere in vetro**  
CHF 151.– 40.000.915.00

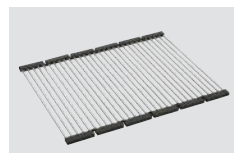
**Holz-Schneidebrett aus Nussbaum**  
**Tagliere in legno di noce**  
CHF 151.– 40.001.147.00

**Inox Pad**  
CHF 125.– 40.001.138.00

**Flächenbündiger Einbau: Empfehlung zur Wahl der Arbeitsplatte**

Wir empfehlen den Einbau in Arbeitsplatten aus Keramik, Granit, Kunststein (z.B. Corian oder Varicor) oder Massivholz. Vom Einbau in beschichtete Spanplatten raten wir ab.

**Montaggio a filo top: Consiglio per la scelta del piano di lavoro**

Consigliamo il montaggio nei piani di lavoro in ceramica, granito, pietra artificiale (per es. Corian o Varicor) oppure in legno massiccio. Sconsigliamo la posa in pannelli di truciolato rivestiti.

**1 Produktausführung, 2 Montagearten**

Der besondere Vorteil von IF-Modellen: Sowohl der flächenbündige Einbau als auch der flach aufliegende Einbau ist möglich.

**1 versione di prodotto, 2 metodi di montaggio**

I modelli IF presentano un grande vantaggio: possono essere posati sia a filo top che sopra piano.

 Varianten: Der Austausch von Zugknöpfen erfolgt mittels Variantencode. Mehr Infos siehe Seite 395.  
Varianti: La sostituzione di pomoli avviene mediante codice variante. Per maggiori informazioni, vedere pag.395.

Preis CHF / Prezzo in CHF

Modell Modello	Material Materiale	Ventil sFlow, Typ S Piletta sFlow, tipo S	Artikel-Nr. N. di articolo	Beckentiefe Profondità	Exkl. MWST IVA esclusa	Inkl. MWST IVA inclusa	VRG TRA		
Vantis V 50-42IF/12	Edelstahl, matt Acciaio inox, opaco	18 / 10	3 1/2" TouchFlow	10.104.236.00	175 mm	A	1235.–	1335.–	0.19
			3 1/2" Raumspar Salvaspazio	10.104.237.00	175 mm	A	1037.–	1121.–	
			3 1/2" Tipo	10.104.238.00	175 mm	A	988.–	1068.–	

# Vantis: V 50-42IF/12

Randbreite 12 mm  
Larghezza bordo 12 mm

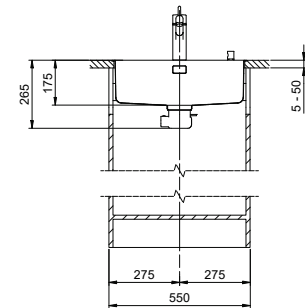
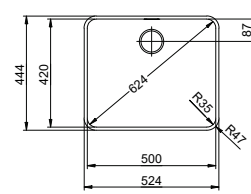

eFlow mit eControl  
eFlow con eControl

Schwenkbare Überlaufkappe  
Placchetta di troppopieno a ribalta

Desino: Verdeckter Ablauf mit untenliegendem Korb  
Desino: Scarico coperto con griglietta inferiore



Für eFlow Desino  
Per eFlow Desino

Für TouchFlow Desino, Raumspaar Desino und Typo Desino  
Per TouchFlow Desino, Salvaspazio Desino e Tipo Desino

Für eFlow Desino, TouchFlow Desino, Raumspaar Desino und Typo Desino  
Per eFlow Desino, TouchFlow Desino, Salvaspazio Desino e Tipo Desino

## Optionales Zubehör / Accessori opzionali



**Resteschale gelocht**  
Vaschetta forato

CHF 106.– 40.000.914.00



**Resteschale ungelocht**  
Vaschetta non forato

CHF 106.– 40.001.290.00



**Schneidebrett aus Glas**  
Tagliere in vetro

CHF 151.– 40.000.915.00



**Holz-Schneidebrett aus Nussbaum**  
Tagliere in legno di noce

CHF 151.– 40.001.147.00

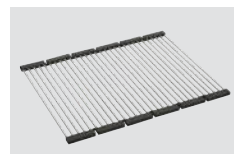

**Inox Pad**

CHF 125.– 40.001.138.00

Zeichnung als pdf / dxf und Montageanleitung siehe:  
V. disegno in formato pdf / dxf e montaggio:  
suter.ch

**Flächenbündiger Einbau: Empfehlung zur Wahl der Arbeitsplatte**  
Wir empfehlen den Einbau in Arbeitsplatten aus Keramik, Granit, Kunststein (z.B. Corian oder Varicor) oder Massivholz. Vom Einbau in beschichtete Spanplatten raten wir ab.  
**Montaggio a filo top: Consiglio per la scelta del piano di lavoro**  
Consigliamo il montaggio nei piani di lavoro in ceramica, granito, pietra artificiale (per es. Corian o Varicor) oppure in legno massiccio. Sconsigliamo la posa in pannelli di truciolato rivestiti.

**1 Produktausführung, 2 Montagearten**  
Der besondere Vorteil von IF-Modellen: Sowohl der flächenbündige Einbau als auch der flach aufliegende Einbau ist möglich.  
**1 versione di prodotto, 2 metodi di montaggio**  
I modelli IF presentano un grande vantaggio: possono essere posati sia a filo top che sopra piano.

**!** Varianten: Der Austausch von Zugknöpfen erfolgt mittels Variantencode. Mehr Infos siehe Seite 395.  
Varianti: La sostituzione di pomoli avviene mediante codice variante. Per maggiori informazioni, vedere pag. 395.

## Preis CHF / Prezzo in CHF

Modell Modello	Material Materiale	Ventil sFlow, Typ M Piletta sFlow, tipo M	Artikel-Nr. N. di articolo	Beckentiefe Profondità	Exkl. MWST IVA esclusa	Inkl. MWST IVA inclusa	VRG TRA	
<b>Vantis V 50-42IF/12</b>	Edelstahl, matt Acciaio inox, opaco	18/10	3 1/2" eFlow Desino	10.105.280.00	175 mm	A 1502.–	1624.–	0.19
		3 1/2" TouchFlow Desino	10.105.212.00	175 mm	A 1387.–	1499.–	0.19	
		3 1/2" Raumspaar Desino Salvaspazio Desino	10.105.213.00	175 mm	A 1177.–	1272.–		
		3 1/2" Typo Desino	10.105.749.00	175 mm	A 1177.–	1272.–		

## Vantis: V 50-35IF/12

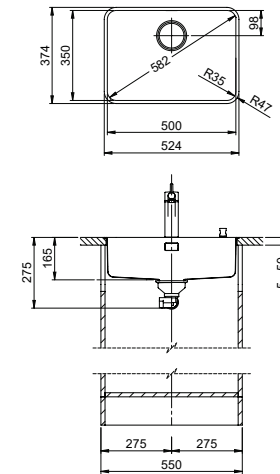
Randbreite 12 mm  
Larghezza bordo 12 mm

 Schwenkbare Überlaufkappe  
Placchetta di troppopieno a ribalta

15

 Obenliegendes Sieb  
Griglietta superiore

14



Zeichnung als pdf / dxf und Montageanleitung siehe:  
V. disegno in formato pdf / dxf e montaggio:  
suter.ch

## Optionales Zubehör / Accessori opzionali

312



Resteschale gelocht  
Vaschetta forato  
CHF 106.– 40.000.916.00

**Flächenbündiger Einbau: Empfehlung zur Wahl der Arbeitsplatte**

Wir empfehlen den Einbau in Arbeitsplatten aus Keramik, Granit, Kunststein (z.B. Corian oder Varicor) oder Massivholz. Vom Einbau in beschichtete Spanplatten raten wir ab.

**Montaggio a filo top: Consiglio per la scelta del piano di lavoro**

Consigliamo il montaggio nei piani di lavoro in ceramica, granito, pietra artificiale (per es. Corian o Varicor) oppure in legno massiccio. Sconsigliamo la posa in pannelli di truciolato rivestiti.

**1 Produktausführung, 2 Montagearten**

Der besondere Vorteil von IF-Modellen: Sowohl der flächenbündige Einbau als auch der flach aufliegende Einbau ist möglich.

**1 versione di prodotto, 2 metodi di montaggio**

I modelli IF presentano un grande vantaggio: possono essere posati sia a filo top che sopra piano.

Varianten: Der Austausch von Zugknöpfen erfolgt mittels Variantencode. Mehr Infos siehe Seite 395.  
Varianti: La sostituzione di pomoli avviene mediante codice variante. Per maggiori informazioni, vedere pag.395.

Preis CHF / Prezzo in CHF

Modell Modello	Material Materiale	Ventil sFlow, Typ S Piletta sFlow, tipo S	Artikel-Nr. N. di articolo	Beckentiefe Profondità	Exkl. MWST IVA esclusa	Inkl. MWST IVA inclusa	VRG TRA		
Vantis V 50-35IF/12	Edelstahl, matt Acciaio inox, opaco	18 / 10	3 1/2" TouchFlow	10.104.242.00	165 mm	A	1066.–	1152.–	0.19
			3 1/2" Raumspar Salvaspazio	10.104.243.00	165 mm	A	868.–	938.–	
			3 1/2" Tipo	10.104.244.00	165 mm	A	819.–	885.–	

# Vantis: V 50-35IF/12

Randbreite 12 mm  
Larghezza bordo 12 mm

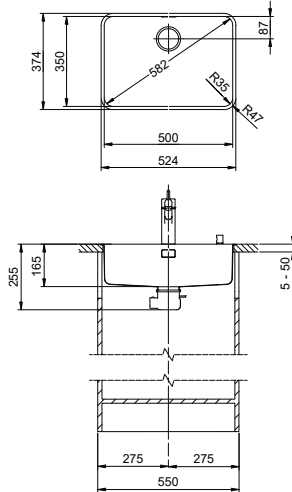

eFlow mit eControl  
eFlow con eControl

Schwenkbare Überlaufkappe  
Placchetta di troppopieno a ribalta

Desino: Verdeckter Ablauf mit untenliegendem Korb  
Desino: Scarico coperto con griglietta inferiore



Für eFlow Desino  
Per eFlow Desino

Für TouchFlow Desino, Raumspas Desino und Tipo Desino  
Per TouchFlow Desino, Salvaspazio Desino e Tipo Desino



Für eFlow Desino, TouchFlow Desino, Raumspas Desino und Tipo Desino  
Per eFlow Desino, TouchFlow Desino, Salvaspazio Desino e Tipo Desino

## Optionales Zubehör / Accessori opzionali

312



**Resteschale gelocht**  
**Vaschetta forato**  
CHF 106.– 40.000.916.00

Zeichnung als pdf / dxf und Montageanleitung siehe:  
V. disegno in formato pdf / dxf e montaggio:  
suter.ch

**Flächenbündiger Einbau: Empfehlung zur Wahl der Arbeitsplatte**  
Wir empfehlen den Einbau in Arbeitsplatten aus Keramik, Granit, Kunststein (z.B. Corian oder Varicor) oder Massivholz. Vom Einbau in beschichtete Spanplatten raten wir ab.

**Montaggio a filo top: Consiglio per la scelta del piano di lavoro**  
Consigliamo il montaggio nei piani di lavoro in ceramica, granito, pietra artificiale (per es. Corian o Varicor) oppure in legno massiccio. Sconsigliamo la posa in pannelli di truciolato rivestiti.

**1 Produktausführung, 2 Montagearten**  
Der besondere Vorteil von IF-Modellen: Sowohl der flächenbündige Einbau als auch der flach aufliegende Einbau ist möglich.

**1 versione di prodotto, 2 metodi di montaggio**  
I modelli IF presentano un grande vantaggio: possono essere posati sia a filo top che sopra piano.

Varianten: Der Austausch von Zugknöpfen erfolgt mittels Variantencode. Mehr Infos siehe Seite 395.  
Varianti: La sostituzione di pomoli avviene mediante codice variante. Per maggiori informazioni, vedere pag. 395.

## Preis CHF / Prezzo in CHF

Modell Modello	Material Materiale	Ventil sFlow, Typ M Piletta sFlow, tipo M	Artikel-Nr. N. di articolo	Beckentiefe Profondità	Exkl. MWST IVA esclusa	Inkl. MWST IVA inclusa	VRG TRA		
<b>Vantis V 50-35IF/12</b>	Edelstahl, matt Acciaio inox, opaco	18 / 10	3 1/2" eFlow Desino	10.105.276.00	165 mm	A	1333.–	1441.–	0.19
		3 1/2" TouchFlow Desino	10.105.277.00	165 mm	A	1218.–	1317.–	0.19	
		3 1/2" Raumspas Desino Salvaspazio Desino	10.105.278.00	165 mm	A	1008.–	1090.–		
		3 1/2" Tipo Desino	10.105.753.00	165 mm	A	1008.–	1090.–		

## Vantis: V 55IF/12

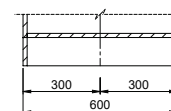
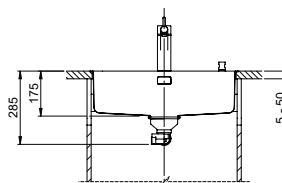
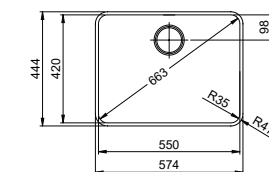
Randbreite 12 mm  
Larghezza bordo 12 mm
**Schwenkbare Überlaufkappe**  
Placchetta di troppopieno a ribalta

**Obenliegendes Sieb**  
Griglietta superiore

14



Zeichnung als pdf / dxf und Montageanleitung siehe:  
V. disegno in formato pdf / dxf e montaggio:  
suter.ch

## Optionales Zubehör / Accessori opzionali

312

**Resteschale gelocht**  
**Vaschetta forato**

CHF 106.– 40.000.914.00

**Resteschale ungelocht**  
**Vaschetta non forato**

CHF 106.– 40.001.290.00

**Schneidebrett aus Glas**  
**Tagliere in vetro**

CHF 151.– 40.000.915.00

**Holz-Schneidebrett aus Nussbaum**  
**Tagliere in legno di noce**

CHF 151.– 40.001.147.00

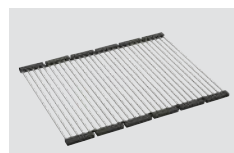
**Inox Pad**

CHF 125.– 40.001.138.00

**Flächenbündiger Einbau: Empfehlung zur Wahl der Arbeitsplatte**

Wir empfehlen den Einbau in Arbeitsplatten aus Keramik, Granit, Kunststein (z.B. Corian oder Varicor) oder Massivholz. Vom Einbau in beschichtete Spanplatten raten wir ab.

**Montaggio a filo top: Consiglio per la scelta del piano di lavoro**

Consigliamo il montaggio nei piani di lavoro in ceramica, granito, pietra artificiale (per es. Corian o Varicor) oppure in legno massiccio. Sconsigliamo la posa in pannelli di truciolato rivestiti.

**1 Produktausführung, 2 Montagearten**

Der besondere Vorteil von IF-Modellen: Sowohl der flächenbündige Einbau als auch der flach aufliegende Einbau ist möglich.

**1 versione di prodotto, 2 metodi di montaggio**

I modelli IF presentano un grande vantaggio: possono essere posati sia a filo top che sopra piano.

**Varianten:** Der Austausch von Zugknöpfen erfolgt mittels Variantencode. Mehr Infos siehe Seite 395.  
**Varianti:** La sostituzione di pomoli avviene mediante codice variante. Per maggiori informazioni, vedere pag. 395.

**Preis CHF / Prezzo in CHF**

Modell Modello	Material Materiale	Ventil sFlow, Typ S Piletta sFlow, tipo S	Artikel-Nr. N. di articolo	Beckentiefe Profondità	Exkl. MWST IVA esclusa	Inkl. MWST IVA inclusa	VRG TRA		
Vantis V 55IF/12	Edelstahl, matt Acciaio inox, opaco	18 / 10	3 1/2" TouchFlow	10.104.248.00	175 mm	A	1376.–	1487.–	0.19
			3 1/2" Raumspar Salvaspazio	10.104.249.00	175 mm	A	1178.–	1273.–	
			3 1/2" Tipo	10.104.250.00	175 mm	A	1129.–	1220.–	

# Vantis: V 55IF/12

Randbreite 12 mm  
Larghezza bordo 12 mm

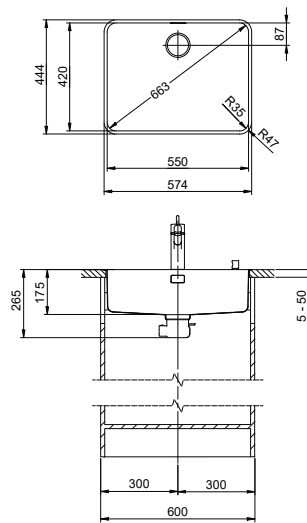

eFlow mit eControl  
eFlow con eControl

Schwenkbare Überlaufkappe  
Placchetta di troppopieno a ribalta

Desino: Verdeckter Ablauf mit untenliegendem Korb  
Desino: Scarico coperto con griglietta inferiore



Für eFlow Desino  
Per eFlow Desino

Für TouchFlow Desino, Raumspar Desino und Tipo Desino  
Per TouchFlow Desino, Salvaspazio Desino e Tipo Desino

Für eFlow Desino, TouchFlow Desino, Raumspar Desino und Tipo Desino  
Per eFlow Desino, TouchFlow Desino, Salvaspazio Desino e Tipo Desino

## Optionales Zubehör / Accessori opzionali



**Resteschale gelocht**  
Vaschetta forato  
CHF 106.– 40.000.914.00



**Resteschale ungelocht**  
Vaschetta non forato  
CHF 106.– 40.001.290.00



**Schneidebrett aus Glas**  
Tagliere in vetro  
CHF 151.– 40.000.915.00



**Holz-Schneidebrett aus Nussbaum**  
Tagliere in legno di noce  
CHF 151.– 40.001.147.00

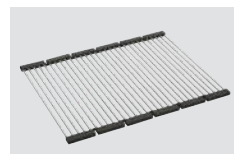

**Inox Pad**  
CHF 125.– 40.001.138.00

Zeichnung als pdf / dxf und Montageanleitung siehe:  
V. disegno in formato pdf / dxf e montaggio:  
suter.ch

**Flächenbündiger Einbau: Empfehlung zur Wahl der Arbeitsplatte**  
Wir empfehlen den Einbau in Arbeitsplatten aus Keramik, Granit, Kunststein (z.B. Corian oder Varicor) oder Massivholz. Vom Einbau in beschichtete Spanplatten raten wir ab.  
**Montaggio a filo top: Consiglio per la scelta del piano di lavoro**  
Consigliamo il montaggio nei piani di lavoro in ceramica, granito, pietra artificiale (per es. Corian o Varicor) oppure in legno massiccio. Sconsigliamo la posa in pannelli di truciolato rivestiti.

**1 Produktausführung, 2 Montagearten**  
Der besondere Vorteil von IF-Modellen: Sowohl der flächenbündige Einbau als auch der flach aufliegende Einbau ist möglich.  
**1 versione di prodotto, 2 metodi di montaggio**  
I modelli IF presentano un grande vantaggio: possono essere posati sia a filo top che sopra piano.

Varianten: Der Austausch von Zugknöpfen erfolgt mittels Variantencode. Mehr Infos siehe Seite 395.  
Varianti: La sostituzione di pomoli avviene mediante codice variante. Per maggiori informazioni, vedere pag. 395.

## Preis CHF / Prezzo in CHF

Modell Modello	Material Materiale	Ventil sFlow, Typ M Piletta sFlow, tipo M	Artikel-Nr. N. di articolo	Beckentiefe Profondità	Exkl. MWST IVA esclusa	Inkl. MWST IVA inclusa	VRG TRA	
Vantis V 55IF/12	Edelstahl, matt Acciaio inox, opaco	18/10	3 1/2" eFlow Desino	10.105.281.00	175 mm	A 1643.–	1776.–	0.19
			3 1/2" TouchFlow Desino	10.105.214.00	175 mm	A 1528.–	1652.–	0.19
			3 1/2" Raumspar Desino Salvaspazio Desino	10.105.215.00	175 mm	A 1318.–	1425.–	
			3 1/2" Tipo Desino	10.105.757.00	175 mm	A 1318.–	1425.–	

## Vantis: VG 45IF/12 Green

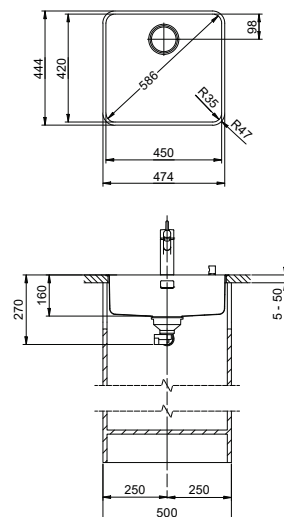
Randbreite 12 mm  
Larghezza bordo 12 mm

 Schwenkbare Überlaufkappe  
Placchetta di troppopieno a ribalta

15

 Obenliegendes Sieb  
Griglietta superiore

14

 Zeichnung als pdf / dxf und Montageanleitung siehe:  
V. disegno in formato pdf / dxf e montaggio:  
suter.ch

## Optionales Zubehör / Accessori opzionali

312

**Resteschale gelocht**  
Vaschetta forato  
CHF 106.– 40.000.914.00

**Resteschale ungelocht**  
Vaschetta non forato  
CHF 106.– 40.001.290.00

**Schneidebrett aus Glas**  
Tagliere in vetro  
CHF 151.– 40.000.915.00

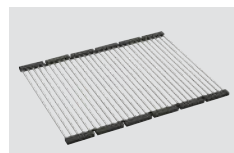
**Holz-Schneidebrett aus Nussbaum**  
Tagliere in legno di noce  
CHF 151.– 40.001.147.00

**Inox Pad**  
CHF 125.– 40.001.138.00

**Flächenbündiger Einbau: Empfehlung zur Wahl der Arbeitsplatte**

Wir empfehlen den Einbau in Arbeitsplatten aus Keramik, Granit, Kunststein (z.B. Corian oder Varicor) oder Massivholz. Vom Einbau in beschichtete Spanplatten raten wir ab.

**Montaggio a filo top: Consiglio per la scelta del piano di lavoro**

Consigliamo il montaggio nei piani di lavoro in ceramica, granito, pietra artificiale (per es. Corian o Varicor) oppure in legno massiccio. Sconsigliamo la posa in pannelli di truciolato rivestiti.

**1 Produktausführung, 2 Montagearten**

Der besondere Vorteil von IF-Modellen: Sowohl der flächenbündige Einbau als auch der flach aufliegende Einbau ist möglich.

**1 versione di prodotto, 2 metodi di montaggio**

I modelli IF presentano un grande vantaggio: possono essere posati sia a filo top che sopra piano.

 Green Line ist eine eigenständige auf Nachhaltigkeit ausgerichtete Produktausführung.  
Green Line è una versione di prodotto autonoma calibrata sulla sostenibilità.



 Varianten: Der Austausch von Zugknöpfen erfolgt mittels Variantencode. Mehr Infos siehe Seite 395.  
Varianti: La sostituzione di pomoli avviene mediante codice variante. Per maggiori informazioni, vedere pag.395.

Preis CHF / Prezzo in CHF

Modell Modello	Material Materiale	Ventil sFlow, Typ S Piletta sFlow, tipo S	Artikel-Nr. N. di articolo	Beckentiefe Profondità	Exkl. MWST IVA esclusa	Inkl. MWST IVA inclusa	VRG TRA		
Vantis VG 45IF/12 Green	Edelstahl, matt Acciaio inox, opaco	18/10	3 1/2" TouchFlow	10.105.778.00	160 mm	A	1182.–	1278.–	0.19
			3 1/2" Raumspar Salvaspazio	10.105.779.00	160 mm	A	984.–	1064.–	
			3 1/2" Tipo	10.105.780.00	160 mm	A	935.–	1011.–	

# Vantis: VG 50-42IF/12 Green

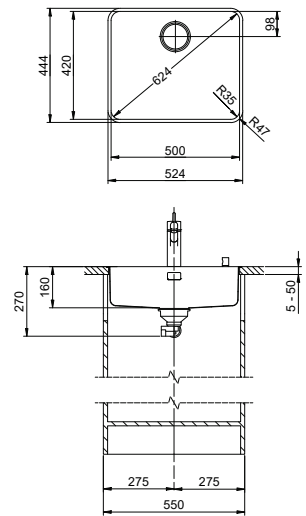
Randbreite 12 mm  
Larghezza bordo 12 mm



Schwenkbare Überlaufkappe  
Placchetta di troppopieno a ribalta

Obenliegendes Sieb  
Griglietta superiore



Zeichnung als pdf / dxf und Montageanleitung siehe:  
V. disegno in formato pdf / dxf e montaggio:  
suter.ch

## Optionales Zubehör / Accessori opzionali



**Resteschale gelocht**  
Vaschetta forato  
CHF 106.- 40.000.914.00

**Resteschale ungelocht**  
Vaschetta non forato  
CHF 106.- 40.001.290.00

**Schneidebrett aus Glas**  
Tagliere in vetro  
CHF 151.- 40.000.915.00

**Holz-Schneidebrett aus Nussbaum**  
Tagliere in legno di noce  
CHF 151.- 40.001.147.00

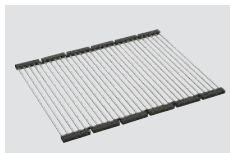

**Innox Pad**  
CHF 125.- 40.001.138.00

**Flächenbündiger Einbau: Empfehlung zur Wahl der Arbeitsplatte**  
Wir empfehlen den Einbau in Arbeitsplatten aus Keramik, Granit, Kunststein (z.B. Corian oder Varicor) oder Massivholz. Vom Einbau in beschichtete Spanplatten raten wir ab.

**Montaggio a filo top: Consiglio per la scelta del piano di lavoro**  
Consigliamo il montaggio nei piani di lavoro in ceramica, granito, pietra artificiale (per es. Corian o Varicor) oppure in legno massiccio. Sconsigliamo la posa in pannelli di truciolato rivestiti.

**1 Produktausführung, 2 Montagearten**  
Der besondere Vorteil von IF-Modellen: Sowohl der flächenbündige Einbau als auch der flach aufliegende Einbau ist möglich.

**1 versione di prodotto, 2 metodi di montaggio**  
I modelli IF presentano un grande vantaggio: possono essere posati sia a filo top che sopra piano.

**GREEN LINE** Green Line ist eine eigenständige auf Nachhaltigkeit ausgerichtete Produktausführung.  
Green Line è una versione di prodotto autonoma calibrata sulla sostenibilità.

Varianten: Der Austausch von Zugknöpfen erfolgt mittels Variantencode. Mehr Infos siehe Seite 395.  
Varianti: La sostituzione di pomoli avviene mediante codice variante. Per maggiori informazioni, vedere pag.395.

## Preis CHF / Prezzo in CHF

Modell Modello	Material Materiale	Ventil sFlow, Typ S Piletta sFlow, tipo S	Artikel-Nr. N. di articolo	Beckentiefe Profondità	Exkl. MWST IVA esclusa	Inkl. MWST IVA inclusa	VRG TRA		
<b>Vantis VG 50-42IF/12 Green</b>	Edelstahl, matt Acciaio inox, opaco	18 / 10	3 1/2" TouchFlow	10.105.781.00	160 mm	A	1296.-	1401.-	0.19
			3 1/2" Raumspar Salvaspazio	10.105.782.00	160 mm	A	1098.-	1187.-	
			3 1/2" Tipo	10.105.783.00	160 mm	A	1049.-	1134.-	

## Vantis: VG 50-35IF/12 Green

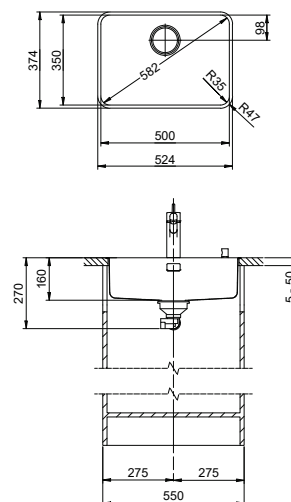
Randbreite 12 mm  
Larghezza bordo 12 mm

 Schwenkbare Überlaufkappe  
Placchetta di troppopieno a ribalta

 Obenliegendes Sieb  
Griglietta superiore

14

 Zeichnung als pdf / dxf und Montageanleitung siehe:  
V. disegno in formato pdf / dxf e montaggio:  
suter.ch

## Optionales Zubehör / Accessori opzionali

312

 Resteschale gelocht  
Vaschetta forato  
CHF 106.– 40.000.916.00

**Flächenbündiger Einbau: Empfehlung zur Wahl der Arbeitsplatte**

Wir empfehlen den Einbau in Arbeitsplatten aus Keramik, Granit, Kunststein (z.B. Corian oder Varicor) oder Massivholz. Vom Einbau in beschichtete Spanplatten raten wir ab.

**Montaggio a filo top: Consiglio per la scelta del piano di lavoro**

Consigliamo il montaggio nei piani di lavoro in ceramica, granito, pietra artificiale (per es. Corian o Varicor) oppure in legno massiccio. Sconsigliamo la posa in pannelli di truciolato rivestiti.

**1 Produktausführung, 2 Montagearten**

Der besondere Vorteil von IF-Modellen: Sowohl der flächenbündige Einbau als auch der flach aufliegende Einbau ist möglich.

**1 versione di prodotto, 2 metodi di montaggio**

I modelli IF presentano un grande vantaggio: possono essere posati sia a filo top che sopra piano.

 Green Line ist eine eigenständige auf Nachhaltigkeit ausgerichtete Produktausführung.  
Green Line è una versione di prodotto autonoma calibrata sulla sostenibilità.



 Varianten: Der Austausch von Zugknöpfen erfolgt mittels Variantencode. Mehr Infos siehe Seite 395.  
Varianti: La sostituzione di pomoli avviene mediante codice variante. Per maggiori informazioni, vedere pag.395.

Preis CHF / Prezzo in CHF

Modell Modello	Material Materiale	Ventil sFlow, Typ S Piletta sFlow, tipo S	Artikel-Nr. N. di articolo	Beckentiefe Profondità	Exkl. MWST IVA esclusa	Inkl. MWST IVA inclusa	VRG TRA		
Vantis VG 50-35IF/12 Green	Edelstahl, matt Acciaio inox, opaco	18 / 10	3 1/2" TouchFlow	10.105.784.00	160 mm	A	1137.–	1229.–	0.19
			3 1/2" Raumspar Salvaspazio	10.105.785.00	160 mm	A	939.–	1015.–	
			3 1/2" Tipo	10.105.786.00	160 mm	A	890.–	962.–	

# Vantis: VG 55IF/12 Green

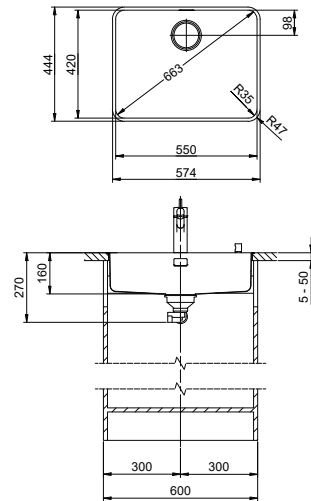
Randbreite 12 mm  
Larghezza bordo 12 mm



Schwenkbare Überlaufkappe  
Placchetta di troppopieno a ribalta

Obenliegendes Sieb  
Griglietta superiore



Zeichnung als pdf / dxf und Montageanleitung siehe:  
V. disegno in formato pdf / dxf e montaggio:  
suter.ch

## Optionales Zubehör / Accessori opzionali



**Resteschale gelocht**  
**Vaschetta forato**

CHF 106.- 40.000.914.00

**Resteschale ungelocht**  
**Vaschetta non forato**

CHF 106.- 40.001.290.00

**Schneidebrett aus Glas**  
**Tagliere in vetro**

CHF 151.- 40.000.915.00

**Holz-Schneidebrett aus Nussbaum**  
**Tagliere in legno di noce**

CHF 151.- 40.001.147.00

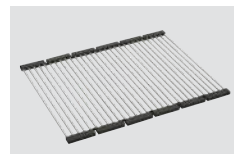

**Innox Pad**

CHF 125.- 40.001.138.00

**Flächenbündiger Einbau: Empfehlung zur Wahl der Arbeitsplatte**  
Wir empfehlen den Einbau in Arbeitsplatten aus Keramik, Granit, Kunststein (z.B. Corian oder Varicor) oder Massivholz. Vom Einbau in beschichtete Spanplatten raten wir ab.

**Montaggio a filo top: Consiglio per la scelta del piano di lavoro**  
Consigliamo il montaggio nei piani di lavoro in ceramica, granito, pietra artificiale (per es. Corian o Varicor) oppure in legno massiccio. Sconsigliamo la posa in pannelli di truciolato rivestiti.

**1 Produktausführung, 2 Montagearten**  
Der besondere Vorteil von IF-Modellen: Sowohl der flächenbündige Einbau als auch der flach aufliegende Einbau ist möglich.

**1 versione di prodotto, 2 metodi di montaggio**  
I modelli IF presentano un grande vantaggio: possono essere posati sia a filo top che sopra piano.

**GREEN LINE** Green Line ist eine eigenständige auf Nachhaltigkeit ausgerichtete Produktausführung.  
Green Line è una versione di prodotto autonoma calibrata sulla sostenibilità.

**!** Varianten: Der Austausch von Zugknöpfen erfolgt mittels Variantencode. Mehr Infos siehe Seite 395.  
Varianti: La sostituzione di pomoli avviene mediante codice variante. Per maggiori informazioni, vedere pag. 395.

## Preis CHF / Prezzo in CHF

Modell Modello	Material Materiale	Ventil sFlow, Typ S Piletta sFlow, tipo S	Artikel-Nr. N. di articolo	Beckentiefe Profondità	Exkl. MWST IVA esclusa	Inkl. MWST IVA inclusa	VRG TRA		
<b>Vantis VG 55IF/12 Green</b>	Edelstahl, matt Acciaio inox, opaco	18 / 10	3 1/2" TouchFlow	10.105.787.00	160 mm	A	1551.-	1677.-	0.19
			3 1/2" Raumspar Salvaspazio	10.105.788.00	160 mm	A	1353.-	1463.-	
			3 1/2" Tipo	10.105.789.00	160 mm	A	1304.-	1410.-	

## Vantis: VX 34IF/15 Varix

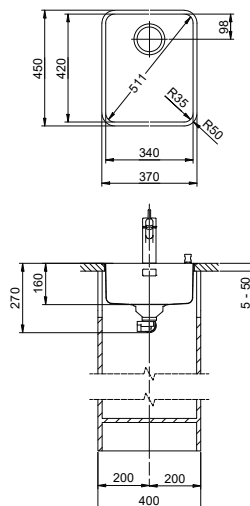
Randbreite 15 mm  
Larghezza bordo 15 mm

 Verdeckter Überlauf  
Trotopieno coperto

 Zeichnung als pdf / dxf und Montageanleitung siehe:  
 V. disegno in formato pdf / dxf e montaggio:  
 suter.ch

## Optionales Zubehör / Accessori opzionali

**Resteschale gelocht**  
**Vaschetta forato**  
 CHF 106.– 40.000.914.00

**Resteschale ungelocht**  
**Vaschetta non forato**  
 CHF 106.– 40.001.290.00

**Schneidebrett aus Glas**  
**Tagliere in vetro**  
 CHF 151.– 40.000.915.00

**Holz-Schneidebrett aus Nussbaum**  
**Tagliere in legno di noce**  
 CHF 151.– 40.001.147.00

**Flächenbündiger Einbau: Empfehlung zur Wahl der Arbeitsplatte**

Wir empfehlen den Einbau in Arbeitsplatten aus Keramik, Granit, Kunststein (z.B. Corian oder Varicor) oder Massivholz. Vom Einbau in beschichtete Spanplatten raten wir ab.

**Montaggio a filo top: Consiglio per la scelta del piano di lavoro**

Consigliamo il montaggio nei piani di lavoro in ceramica, granito, pietra artificiale (per es. Corian o Varicor) oppure in legno massiccio. Sconsigliamo la posa in pannelli di truciolato rivestiti.

**1 Produktausführung, 2 Montagearten**

Der besondere Vorteil von IF-Modellen: Sowohl der flächenbündige Einbau als auch der flach aufliegende Einbau ist möglich.

**1 versione di prodotto, 2 metodi di montaggio**

I modelli IF presentano un grande vantaggio: possono essere posati sia a filo top che sopra piano.

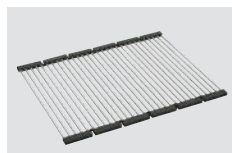
**Inox Pad**

CHF 125.– 40.001.138.00



 Varianten: Der Austausch von Zugknöpfen erfolgt mittels Variantencode. Mehr Infos siehe Seite 395.  
 Varianti: La sostituzione di pomoli avviene mediante codice variante. Per maggiori informazioni, vedere pag. 395.

**Preis CHF / Prezzo in CHF**

Modell Modello	Material Materiale	Ventil Piletta	Artikel-Nr. N. di articolo	Beckentiefe Profondità	Exkl. MWST IVA esclusa	Inkl. MWST IVA inclusa
Vantis VX 34IF/15 Varix	Edelstahl, mid-matt Acciaio inox, mid-matt	18/10 3 1/2" Raumspär Salvaspazio	10.105.252.00	160 mm	A 728.–	787.–
		3 1/2" Siebstopfen A tappo con griglietta	10.105.253.00	160 mm	A 679.–	734.–

# Vantis: VX 40IF/15 Varix

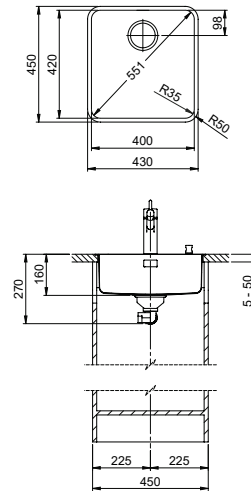
Randbreite 15 mm  
Larghezza bordo 15 mm



Verdeckter Überlauf  
Trooppiano coperto



Zeichnung als pdf / dxf und Montageanleitung siehe:  
V. disegno in formato pdf / dxf e montaggio:  
suter.ch

## Optionales Zubehör / Accessori opzionali



**Resteschale gelocht**  
**Vaschetta forato**  
CHF 106.- 40.000.914.00



**Resteschale ungelocht**  
**Vaschetta non forato**  
CHF 106.- 40.001.290.00



**Schneidebrett aus Glas**  
**Tagliere in vetro**  
CHF 151.- 40.000.915.00



**Holz-Schneidebrett aus Nussbaum**  
**Tagliere in legno di noce**  
CHF 151.- 40.001.147.00

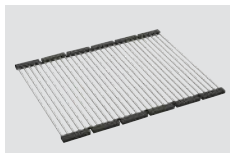

**Inox Pad**  
CHF 125.- 40.001.138.00

**Flächenbündiger Einbau: Empfehlung zur Wahl der Arbeitsplatte**  
Wir empfehlen den Einbau in Arbeitsplatten aus Keramik, Granit, Kunststein (z.B. Corian oder Varicor) oder Massivholz. Vom Einbau in beschichtete Spanplatten raten wir ab.

**Montaggio a filo top: Consiglio per la scelta del piano di lavoro**  
Consigliamo il montaggio nei piani di lavoro in ceramica, granito, pietra artificiale (per es. Corian o Varicor) oppure in legno massiccio. Sconsigliamo la posa in pannelli di truciolato rivestiti.

**1 Produktausführung, 2 Montagearten**  
Der besondere Vorteil von IF-Modellen: Sowohl der flächenbündige Einbau als auch der flach aufliegende Einbau ist möglich.

**1 versione di prodotto, 2 metodi di montaggio**  
I modelli IF presentano un grande vantaggio: possono essere posati sia a filo top che sopra piano.

Varianten: Der Austausch von Zugknöpfen erfolgt mittels Variantencode. Mehr Infos siehe Seite 395.  
Varianti: La sostituzione di pomoli avviene mediante codice variante. Per maggiori informazioni, vedere pag. 395.

### Preis CHF / Prezzo in CHF

Modell Modello	Material Materiale	Ventil Piletta	Artikel-Nr. N. di articolo	Beckentiefe Profondità	Exkl. MWST IVA esclusa	Inkl. MWST IVA inclusa
Vantis VX 40IF/15 Varix	Edelstahl, mid-matt Acciaio inox, mid-matt	18/10 3 1/2" Raumspaar Salvaspazio	10.104.155.00	160 mm	A 748.-	809.-
		3 1/2" Siebstopfen A tappo con griglietta	10.104.156.00	160 mm	A 699.-	756.-

## Vantis : VX 45IF/15 Varix

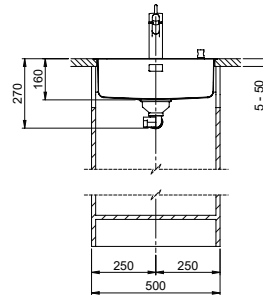
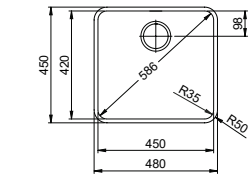
Randbreite 15 mm  
Larghezza bordo 15 mm

 Verdeckter Überlauf  
Troppopieno coperto

15

 Zeichnung als pdf / dxf und Montageanleitung siehe:  
V. disegno in formato pdf / dxf e montaggio:  
suter.ch

## Optionales Zubehör / Accessori opzionali

312

**Resteschale gelocht**  
**Vaschetta forato**  
CHF 106.– 40.000.914.00

**Resteschale ungelocht**  
**Vaschetta non forato**  
CHF 106.– 40.001.290.00

**Schneidebrett aus Glas**  
**Tagliere in vetro**  
CHF 151.– 40.000.915.00

**Holz-Schneidebrett aus Nussbaum**  
**Tagliere in legno di noce**  
CHF 151.– 40.001.147.00
**Flächenbündiger Einbau: Empfehlung zur Wahl der Arbeitsplatte**

Wir empfehlen den Einbau in Arbeitsplatten aus Keramik, Granit, Kunststein (z.B. Corian oder Varicor) oder Massivholz. Vom Einbau in beschichtete Spanplatten raten wir ab.

**Montaggio a filo top: Consiglio per la scelta del piano di lavoro**

Consigliamo il montaggio nei piani di lavoro in ceramica, granito, pietra artificiale (per es. Corian o Varicor) oppure in legno massiccio. Sconsigliamo la posa in pannelli di truciolato rivestiti.

**1 Produktausführung, 2 Montagearten**

Der besondere Vorteil von IF-Modellen: Sowohl der flächenbündige Einbau als auch der flach aufliegende Einbau ist möglich.

**1 versione di prodotto, 2 metodi di montaggio**

I modelli IF presentano un grande vantaggio: possono essere posati sia a filo top che sopra piano.

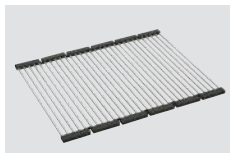
**Inox Pad**  
CHF 125.– 40.001.138.00

 Varianten: Der Austausch von Zugknöpfen erfolgt mittels Variantencode. Mehr Infos siehe Seite 395.  
Varianti: La sostituzione di pomoli avviene mediante codice variante. Per maggiori informazioni, vedere pag. 395.

Preis CHF / Prezzo in CHF

Modell Modello	Material Materiale	Ventil Piletta	Artikel-Nr. N. di articolo	Beckentiefe Profondità	Exkl. MWST IVA esclusa	Inkl. MWST IVA inclusa
Vantis VX 45IF/15 Varix	Edelstahl, mid-matt Acciaio inox, mid-matt	18/10 3 1/2" Raumspär Salvaspazio	10.104.157.00	160 mm	A 772.–	835.–
		3 1/2" Siebstopfen A tappo con griglietta	10.104.158.00	160 mm	A 723.–	782.–

# Vantis : VX 50-42IF/15 Varix

Randbreite 15 mm  
Larghezza bordo 15 mm

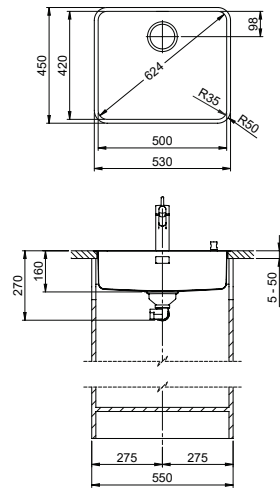

Verdeckter Überlauf  
Troppopieno coperto



Zeichnung als pdf / dxf und Montageanleitung siehe:  
V. disegno in formato pdf / dxf e montaggio:  
suter.ch

## Optionales Zubehör / Accessori opzionali



**Resteschale gelocht**  
**Vaschetta forata**  
CHF 106.- 40.000.914.00



**Resteschale ungelocht**  
**Vaschetta non forata**  
CHF 106.- 40.001.290.00



**Schneidebrett aus Glas**  
**Tagliere in vetro**  
CHF 151.- 40.000.915.00



**Holz-Schneidebrett aus Nussbaum**  
**Tagliere in legno di noce**  
CHF 151.- 40.001.147.00



### Flächenbündiger Einbau: Empfehlung zur Wahl der Arbeitsplatte

Wir empfehlen den Einbau in Arbeitsplatten aus Keramik, Granit, Kunststein (z.B. Corian oder Varicor) oder Massivholz. Vom Einbau in beschichtete Spanplatten raten wir ab.

### Montaggio a filo top: Consiglio per la scelta del piano di lavoro

Consigliamo il montaggio nei piani di lavoro in ceramica, granito, pietra artificiale (per es. Corian o Varicor) oppure in legno massiccio. Sconsigliamo la posa in pannelli di truciolato rivestiti.



### 1 Produktausführung, 2 Montagearten

Der besondere Vorteil von IF-Modellen: Sowohl der flächenbündige Einbau als auch der flach aufliegende Einbau ist möglich.



### 1 versione di prodotto, 2 metodi di montaggio

I modelli IF presentano un grande vantaggio: possono essere posati sia a filo top che sopra piano.

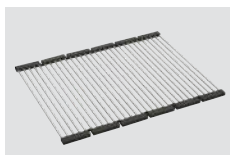

**Inox Pad**  
CHF 125.- 40.001.138.00



Varianten: Der Austausch von Zugknöpfen erfolgt mittels Variantencode. Mehr Infos siehe Seite 395.  
Varianti: La sostituzione di pomoli avviene mediante codice variante. Per maggiori informazioni, vedere pag. 395.

## Preis CHF / Prezzo in CHF

Modell Modello	Material Materiale	Ventil Piletta	Artikel-Nr. N. di articolo	Beckentiefe Profondità	Exkl. MWST IVA esclusa	Inkl. MWST IVA inclusa
<b>Vantis</b> <b>VX 50-42IF/15 Varix</b>	Edelstahl, mid-matt Acciaio inox, mid-matt	18/10 3 1/2" Raumspaar Salvaspazio	10.104.159.00	160 mm	A 794.-	858.-
		3 1/2" Siebstopfen A tappo con griglietta	10.104.160.00	160 mm	A 745.-	805.-

## Vantis : VX 55IF/15 Varix

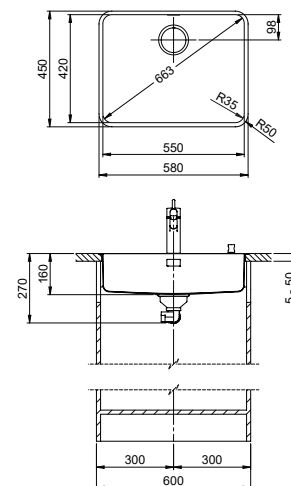
Randbreite 15 mm  
Larghezza bordo 15 mm

 Verdeckter Überlauf  
Trooppiano coperto

 Zeichnung als pdf / dxf und Montageanleitung siehe:  
V. disegno in formato pdf / dxf e montaggio:  
suter.ch

## Optionales Zubehör / Accessori opzionali

**Resteschale gelocht**  
**Vaschetta forata**  
CHF 106.- 40.000.914.00

**Resteschale ungelocht**  
**Vaschetta non forata**  
CHF 106.- 40.001.290.00

**Schneidebrett aus Glas**  
**Tagliere in vetro**  
CHF 151.- 40.000.915.00

**Holz-Schneidebrett aus Nussbaum**  
**Tagliere in legno di noce**  
CHF 151.- 40.001.147.00
**Flächenbündiger Einbau: Empfehlung zur Wahl der Arbeitsplatte**

Wir empfehlen den Einbau in Arbeitsplatten aus Keramik, Granit, Kunststein (z.B. Corian oder Varicor) oder Massivholz. Vom Einbau in beschichtete Spanplatten raten wir ab.

**Montaggio a filo top: Consiglio per la scelta del piano di lavoro**

Consigliamo il montaggio nei piani di lavoro in ceramica, granito, pietra artificiale (per es. Corian o Varicor) oppure in legno massiccio. Sconsigliamo la posa in pannelli di truciolato rivestiti.

**1 Produktausführung, 2 Montagearten**

Der besondere Vorteil von IF-Modellen: Sowohl der flächenbündige Einbau als auch der flach aufliegende Einbau ist möglich.

**1 versione di prodotto, 2 metodi di montaggio**

I modelli IF presentano un grande vantaggio: possono essere posati sia a filo top che sopra piano.

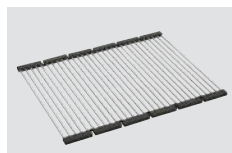
**Inox Pad**

CHF 125.- 40.001.138.00



 Varianten: Der Austausch von Zugknöpfen erfolgt mittels Variantencode. Mehr Infos siehe Seite 395.  
Varianti: La sostituzione di pomoli avviene mediante codice variante. Per maggiori informazioni, vedere pag. 395.

Preis CHF / Prezzo in CHF

Modell Modello	Material Materiale	Ventil Piletta	Artikel-Nr. N. di articolo	Beckentiefe Profondità	Exkl. MWST IVA esclusa	Inkl. MWST IVA inclusa
<b>Vantis</b> <b>VX 55IF/15 Varix</b>	Edelstahl, mid-matt Acciaio inox, mid-matt	3 1/2" Raumspaar Salvaspazio	10.104.161.00	160 mm	A 818.-	884.-
		3 1/2" Siebstopfen A tappo con griglietta	10.104.162.00	160 mm	A 769.-	831.-

# Silver Star: SIL 45IF/12

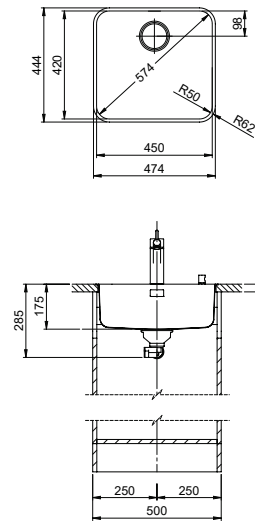
Randbreite 12 mm  
Larghezza bordo 12 mm



Verdeckter Überlauf  
Trooppieno coperto

Obenliegendes Sieb  
Griglietta superiore



Zeichnung als pdf / dxf und Montageanleitung siehe:  
V. disegno in formato pdf / dxf e montaggio:  
suter.ch

## Optionales Zubehör / Accessori opzionali



**Resteschale gelocht**  
**Vaschetta forato**  
CHF 106.- 40.000.914.00



**Resteschale ungelocht**  
**Vaschetta non forato**  
CHF 106.- 40.001.290.00



**Schneidebrett aus Glas**  
**Tagliere in vetro**  
CHF 151.- 40.000.915.00



**Holz-Schneidebrett aus Nussbaum**  
**Tagliere in legno di noce**  
CHF 151.- 40.001.147.00

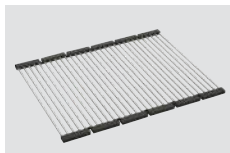

**Inox Pad**  
CHF 125.- 40.001.138.00

**Flächenbündiger Einbau: Empfehlung zur Wahl der Arbeitsplatte**  
Wir empfehlen den Einbau in Arbeitsplatten aus Keramik, Granit, Kunststein (z.B. Corian oder Varicor) oder Massivholz. Vom Einbau in beschichtete Spanplatten raten wir ab.

**Montaggio a filo top: Consiglio per la scelta del piano di lavoro**  
Consigliamo il montaggio nei piani di lavoro in ceramica, granito, pietra artificiale (per es. Corian o Varicor) oppure in legno massiccio. Sconsigliamo la posa in pannelli di truciolato rivestiti.

**1 Produktausführung, 2 Montagearten**  
Der besondere Vorteil von IF-Modellen: Sowohl der flächenbündige Einbau als auch der flach aufliegende Einbau ist möglich.

**1 versione di prodotto, 2 metodi di montaggio**  
I modelli IF presentano un grande vantaggio: possono essere posati sia a filo top che sopra piano.

Varianten: Der Austausch von Zugknöpfen erfolgt mittels Variantencode. Mehr Infos siehe Seite 395.  
Varianti: La sostituzione di pomoli avviene mediante codice variante. Per maggiori informazioni, vedere pag. 395.

## Preis CHF / Prezzo in CHF

Modell Modello	Material Materiale	Ventil Piletta	Artikel-Nr. N. di articolo	Beckentiefe Profondità	Exkl. MWST IVA esclusa	Inkl. MWST IVA inclusa
<b>Silver Star SIL 45IF/12</b>	Edelstahl, matt Acciaio inox, opaco	18/10 3 1/2" Raumspar Salvaspazio	10.104.255.00	175 mm	A 937.-	1013.-
		3 1/2" Tipo	10.104.256.00	175 mm	A 896.-	969.-

## Silver Star: SIS 50IF/12

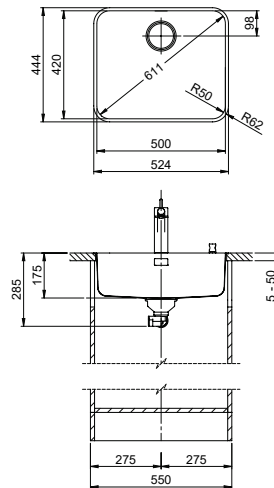
Randbreite 12 mm  
Larghezza bordo 12 mm

 Verdeckter Überlauf  
Troppieno coperto

15

 Obenliegendes Sieb  
Griglietta superiore

14



Zeichnung als pdf / dxf und Montageanleitung siehe:  
V. disegno in formato pdf / dxf e montaggio:  
suter.ch

## Optionales Zubehör / Accessori opzionali

312

**Resteschale gelocht**  
**Vaschetta forato**  
CHF 106.– 40.000.914.00

**Resteschale ungelocht**  
**Vaschetta non forato**  
CHF 106.– 40.001.290.00

**Schneidebrett aus Glas**  
**Tagliere in vetro**  
CHF 151.– 40.000.915.00

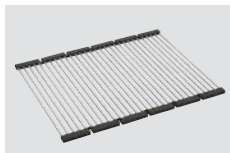
**Holz-Schneidebrett aus Nussbaum**  
**Tagliere in legno di noce**  
CHF 151.– 40.001.147.00

**Inox Pad**  
CHF 125.– 40.001.138.00

**Flächenbündiger Einbau: Empfehlung zur Wahl der Arbeitsplatte**

Wir empfehlen den Einbau in Arbeitsplatten aus Keramik, Granit, Kunststein (z.B. Corian oder Varicor) oder Massivholz. Vom Einbau in beschichtete Spanplatten raten wir ab.

**Montaggio a filo top: Consiglio per la scelta del piano di lavoro**

Consigliamo il montaggio nei piani di lavoro in ceramica, granito, pietra artificiale (per es. Corian o Varicor) oppure in legno massiccio. Sconsigliamo la posa in pannelli di truciolato rivestiti.

**1 Produktausführung, 2 Montagearten**

Der besondere Vorteil von IF-Modellen: Sowohl der flächenbündige Einbau als auch der flach aufliegende Einbau ist möglich.

**1 versione di prodotto, 2 metodi di montaggio**

I modelli IF presentano un grande vantaggio: possono essere posati sia a filo top che sopra piano.

Varianten: Der Austausch von Zugknöpfen erfolgt mittels Variantencode. Mehr Infos siehe Seite 395.  
Varianti: La sostituzione di pomoli avviene mediante codice variante. Per maggiori informazioni, vedere pag. 395.

Preis CHF / Prezzo in CHF

Modell Modello	Material Materiale	Ventil Piletta	Artikel-Nr. N. di articolo	Beckentiefe Profondità	Exkl. MWST IVA esclusa	Inkl. MWST IVA inclusa		
Silver Star SIS 50IF/12	Edelstahl, matt Acciaio inox, opaco	18/10	3 1/2" Raumspar Salvaspazio	10.104.263.00	175 mm	A	1050.–	1135.–
			3 1/2" Tipo	10.104.264.00	175 mm	A	1009.–	1091.–

# Silver Star: SIL 55IF/12

Randbreite 12 mm  
Larghezza bordo 12 mm

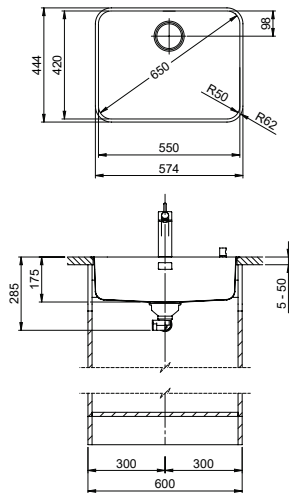

Verdeckter Überlauf  
Trooppiano coperto

Obenliegendes Sieb  
Griglietta superiore



Zeichnung als pdf / dxf und Montageanleitung siehe:  
V. disegno in formato pdf / dxf e montaggio:  
suter.ch

## Optionales Zubehör / Accessori opzionali



**Resteschale gelocht**  
**Vaschetta forato**  
CHF 106.– 40.000.914.00



**Resteschale ungelocht**  
**Vaschetta non forato**  
CHF 106.– 40.001.290.00



**Schneidebrett aus Glas**  
**Tagliere in vetro**  
CHF 151.– 40.000.915.00



**Holz-Schneidebrett aus Nussbaum**  
**Tagliere in legno di noce**  
CHF 151.– 40.001.147.00

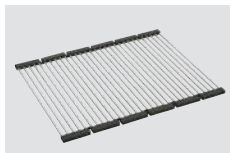

**Inox Pad**  
CHF 125.– 40.001.138.00

**Flächenbündiger Einbau: Empfehlung zur Wahl der Arbeitsplatte**  
Wir empfehlen den Einbau in Arbeitsplatten aus Keramik, Granit, Kunststein (z.B. Corian oder Varicor) oder Massivholz. Vom Einbau in beschichtete Spanplatten raten wir ab.

**Montaggio a filo top: Consiglio per la scelta del piano di lavoro**  
Consigliamo il montaggio nei piani di lavoro in ceramica, granito, pietra artificiale (per es. Corian o Varicor) oppure in legno massiccio. Sconsigliamo la posa in pannelli di truciolato rivestiti.

**1 Produktausführung, 2 Montagearten**  
Der besondere Vorteil von IF-Modellen: Sowohl der flächenbündige Einbau als auch der flach aufliegende Einbau ist möglich.  
 **1 versione di prodotto, 2 metodi di montaggio**  
I modelli IF presentano un grande vantaggio: possono essere posati sia a filo top che sopra piano.

Varianten: Der Austausch von Zugknöpfen erfolgt mittels Variantencode. Mehr Infos siehe Seite 395.  
Varianti: La sostituzione di pomoli avviene mediante codice variante. Per maggiori informazioni, vedere pag. 395.

## Preis CHF / Prezzo in CHF

Modell Modello	Material Materiale	Ventil Piletta	Artikel-Nr. N. di articolo	Beckentiefe Profondità	Exkl. MWST IVA esclusa	Inkl. MWST IVA inclusa
<b>Silver Star SIL 55IF/12</b>	Edelstahl, matt Acciaio inox, opaco	18/10 3 1/2" Raumspar Salvaspazio	10.104.269.00	175 mm	A 1187.–	1283.–
		3 1/2" Tipo	10.104.270.00	175 mm	A 1146.–	1239.–

## Accento: A 65IF/12

Randbreite 12 mm  
Larghezza bordo 12 mm

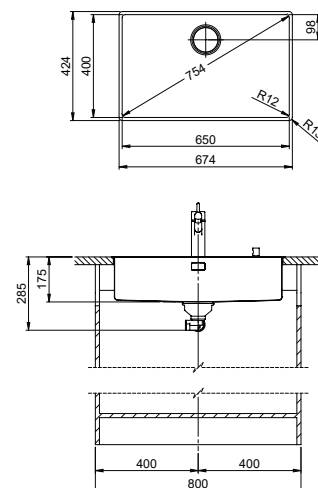
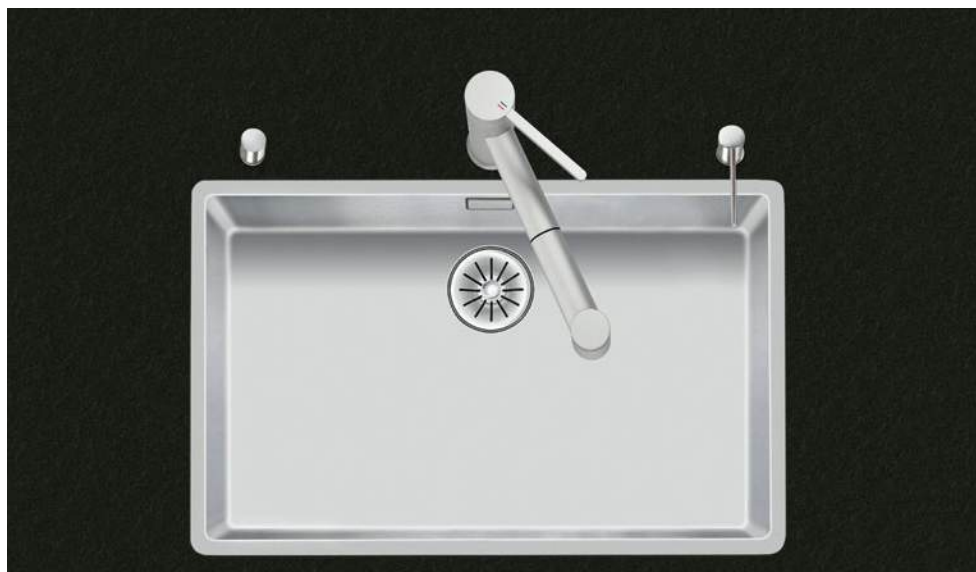

Schwenkbare Überlaufkappe  
Placchetta di troppopieno a ribalta

15

Obenliegendes Sieb  
Griglietta superiore

14



Zeichnung als pdf / dxf und Montageanleitung siehe:  
V. disegno in formato pdf / dxf e montaggio:  
suter.ch

## Optionales Zubehör / Accessori opzionali

312



**Resteschale gelocht**  
**Vaschetta forato**  
CHF 106.– 40.000.912.00



**Resteschale ungelocht**  
**Vaschetta non forato**  
CHF 106.– 40.001.289.00



**Schneidebrett aus Glas**  
**Tagliere in vetro**  
CHF 151.– 40.000.909.00



**Schneidebrett aus Kunststoff**  
**Tagliere sintetico**  
CHF 151.– 40.001.277.00



Alle Accento Modelle werden handgefertigt  
Tutti i modelli Accento sono fabbricati a mano

### Flächenbündiger Einbau: Empfehlung zur Wahl der Arbeitsplatte

Wir empfehlen den Einbau in Arbeitsplatten aus Keramik, Granit, Kunststein (z.B. Corian oder Varicor) oder Massivholz. Vom Einbau in beschichtete Spanplatten raten wir ab.

### Montaggio a filo top: Consiglio per la scelta del piano di lavoro

Consigliamo il montaggio nei piani di lavoro in ceramica, granito, pietra artificiale (per es. Corian o Varicor) oppure in legno massiccio. Sconsigliamo la posa in pannelli di truciolato rivestiti.

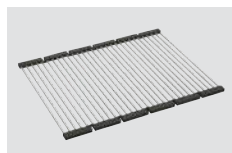

**Inox Pad**  
CHF 125.– 40.001.138.00



### 1 Produktausführung, 2 Montagearten

Der besondere Vorteil von IF-Modellen: Sowohl der flächenbündige Einbau als auch der flach aufliegende Einbau ist möglich.



### 1 versione di prodotto, 2 metodi di montaggio

I modelli IF presentano un grande vantaggio: possono essere posati sia a filo top che sopra piano.

Varianten: Der Austausch von Zugknöpfen erfolgt mittels Variantencode. Mehr Infos siehe Seite 395.  
Varianti: La sostituzione di pomoli avviene mediante codice variante. Per maggiori informazioni, vedere pag. 395.

Preis CHF / Prezzo in CHF

Modell Modello	Material Materiale	Ventil Piletta	Artikel-Nr. N. di articolo	Beckentiefe Profondità	Exkl. MWST IVA esclusa	Inkl. MWST IVA inclusa	VRG TRA		
Accento A 65IF/12	Edelstahl, glanz Acciaio inox, lucido	18 / 10	3 1/2" TouchFlow	10.104.546.00	175 mm	A	2196.–	2374.–	0.19
			3 1/2" Raumspar Salvaspazio	10.104.547.00	175 mm	A	1998.–	2160.–	
			3 1/2" Tipo	10.104.548.00	175 mm	A	1957.–	2116.–	

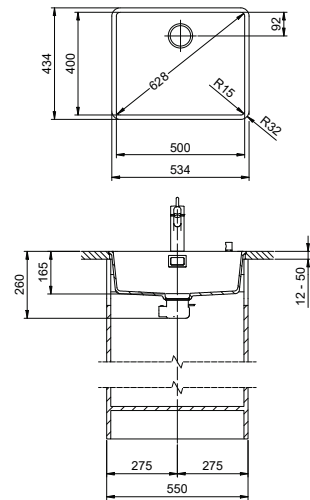
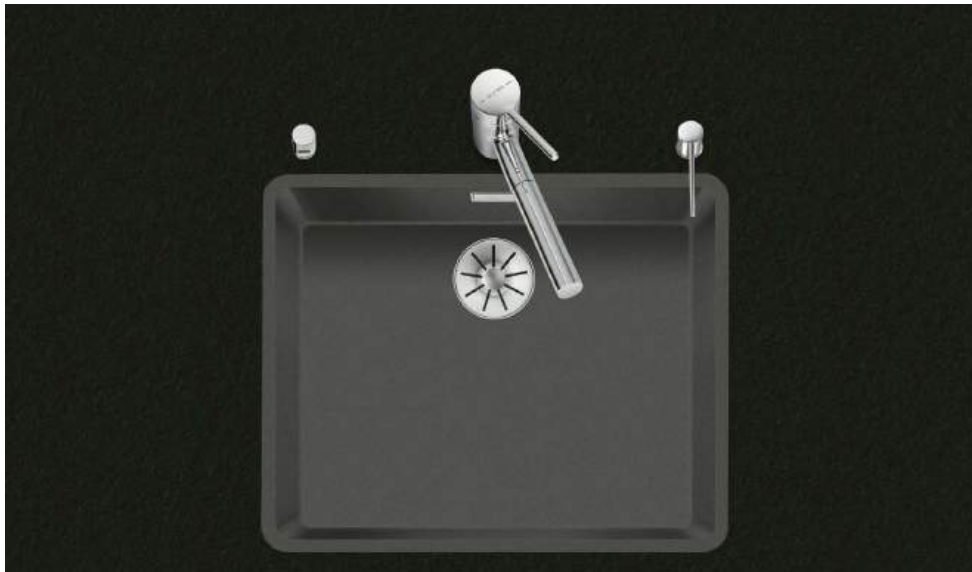

## Linero: LIO CD 50F/17

Randbreite 17 mm  
Larghezza bordo 17 mm**SCHOCK**  
CRISTADUR®

 Schwenkbare Überlaufkappe  
Placchetta di troppopieno a ribalta

15

 Obenliegendes Sieb  
Griglietta superiore

14



Zeichnung als pdf/dxf und Montageanleitung siehe:  
V. disegno in formato pdf/dxf e montaggio:  
suter.ch

## Optionales Zubehör/Accessori opzionali

312

**Resteschale gelocht**  
**Vaschetta forata**  
CHF 106.- 40.000.912.00

**Resteschale ungelocht**  
**Vaschetta non forata**  
CHF 106.- 40.001.289.00

**Schneidebrett aus Glas**  
**Tagliere in vetro**  
CHF 151.- 40.000.909.00

**Schneidebrett aus Kunststoff**  
**Tagliere sintetico**  
CHF 151.- 40.001.277.00



**Nur für flächenbündigen Einbau erhältlich.**  
Disponibile solo per montaggio a filo top.

**Flächenbündiger Einbau: Empfehlung zur Wahl der Arbeitsplatte**

Wir empfehlen den Einbau in Arbeitsplatten aus Keramik, Granit, Kunststein (z.B. Corian oder Varicor) oder Massivholz. Vom Einbau in beschichtete Spanplatten raten wir ab.

**Montaggio a filo top: Consiglio per la scelta del piano di lavoro**

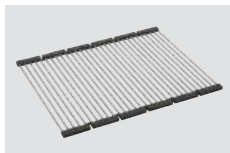
Consigliamo il montaggio nei piani di lavoro in ceramica, granito, pietra artificiale (per es. Corian o Varicor) oppure in legno massiccio. Sconsigliamo la posa in pannelli di truciolato rivestiti.

**Inox Pad**  
CHF 125.- 40.001.138.00

**Reinigungsset Easy Care**  
**Kit di pulizia Easy Care**  
CHF 29.-/N 40.001.509.00

Varianten: Der Austausch von Zugknöpfen und/oder beschichteten Ventilbestandteilen erfolgt mittels Variantencode. Mehr Infos siehe Seite 395.

Varianti: La sostituzione di pomoli e/o componenti piletta rivestiti avviene mediante codice variante. Per maggiori informazioni, vedere pag. 395.

**DEC-Beschichtung, schwarz matt**  
**Rivestimento a DEC, nero opaco**  
**3 1/2" TouchFlow**

CHF 140.-/F 40.002.991.02

**DEC-Beschichtung, schwarz matt**  
**Rivestimento a DEC, nero opaco**  
**3 1/2" Raumspar / Salvaspazio**

CHF 140.-/F 40.002.992.02

**DEC-Beschichtung, schwarz matt**  
**Rivestimento a DEC, nero opaco**  
**3 1/2" Tipo**

CHF 140.-/F 40.002.993.02

**Mehrpriß für beschichtete Ventilbestandteile**

Siebeinsatz, Überlaufblende und Überlaufkappe

**Sovrapprezzo per componenti piletta rivestiti**

Griglietta, mascherina e tappo di troppopieno

Preis CHF / Prezzo in CHF

Modell Modello	Material Materiale	Ventil sFlow, Typ M Piletta sFlow, tipo M	Artikel-Nr. N. di articolo	Beckentiefe Profondità	Exkl. MWST IVA esclusa	Inkl. MWST IVA inclusa	VRG TRA	
<b>Linero LIO CD 50F/17</b>	Cristadur, Puro	3 1/2" TouchFlow	10.105.677.00 	165 mm	B	1495.–	1616.–	0.19
		3 1/2" Druckknopf Pulsante 	10.106.252.00 	165 mm	B	1342.–	1451.–	
		3 1/2" Raumspar Salvaspazio	10.105.678.00 	165 mm	B	1297.–	1402.–	
		3 1/2" Tipo	10.105.679.00 	165 mm	B	1256.–	1358.–	
	Cristadur, Stone	3 1/2" TouchFlow	10.105.685.00 	165 mm	B	1495.–	1616.–	0.19
		3 1/2" Druckknopf Pulsante 	10.106.253.00 	165 mm	B	1342.–	1451.–	
		3 1/2" Raumspar Salvaspazio	10.105.686.00 	165 mm	B	1297.–	1402.–	
		3 1/2" Tipo	10.105.687.00 	165 mm	B	1256.–	1358.–	
	Cristadur, Polaris	3 1/2" TouchFlow	10.105.689.00 	165 mm	B	1495.–	1616.–	0.19
		3 1/2" Druckknopf Pulsante 	10.106.254.00 	165 mm	B	1342.–	1451.–	
		3 1/2" Raumspar Salvaspazio	10.105.690.00 	165 mm	B	1297.–	1402.–	
		3 1/2" Tipo	10.105.691.00 	165 mm	B	1256.–	1358.–	

IF-Spülen  
IF-Lavelli



Linero: LIO CD 50F/17

## Linero: LIO CD 50F/17

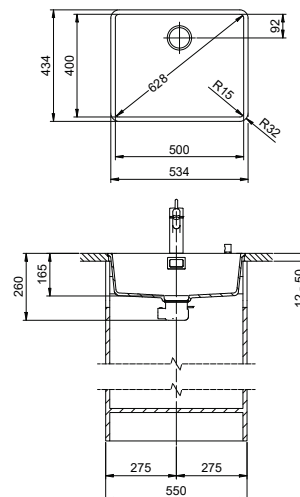
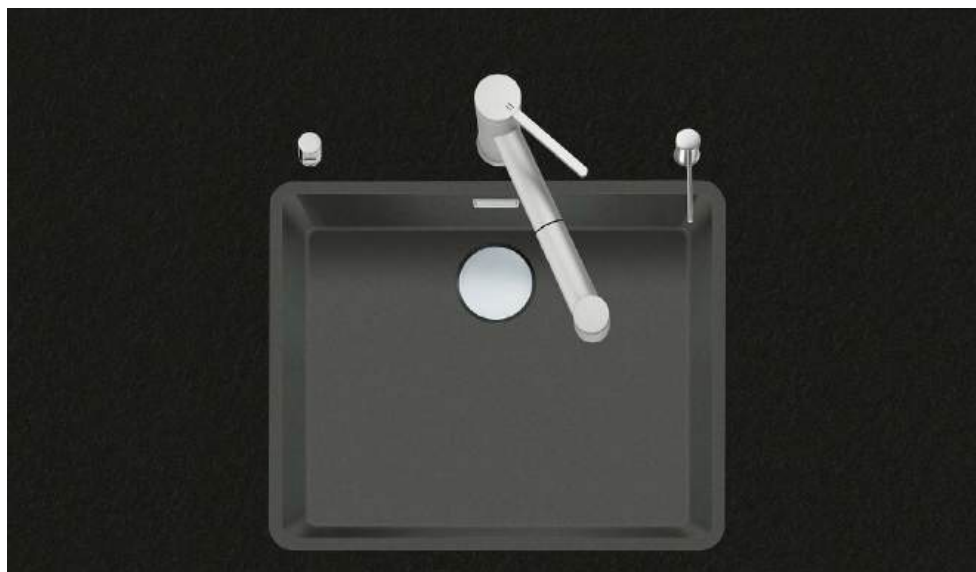
Randbreite 17 mm  
Larghezza bordo 17 mm**SCHOCK**  
CRISTADUR®

 Schwenkbare Überlaufkappe  
Placchetta di troppopieno a ribalta

13

 Desino: Verdeckter Ablauf mit untenliegendem Korb  
Desino: Scarico coperto con griglietta inferiore

14

Für TouchFlow Desino, Raumspar Desino und Tipo Desino  
Per TouchFlow Desino, Salvaspazio Desino e Tipo DesinoFür TouchFlow Desino, Raumspar Desino und Tipo Desino  
Per TouchFlow Desino, Salvaspazio Desino e Tipo DesinoZeichnung als pdf/ dxf und Montageanleitung siehe:  
V. disegno in formato pdf/ dxf e montaggio:  
suter.ch





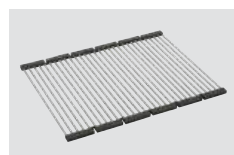







## Optionales Zubehör / Accessori opzionali

312

**Resteschale gelocht**  
**Vaschetta forato**  
CHF 106.– 40.000.912.00**Resteschale ungelocht**  
**Vaschetta non forato**  
CHF 106.– 40.001.289.00**Schneidebrett aus Glas**  
**Tagliere in vetro**  
CHF 151.– 40.000.909.00**Schneidebrett aus Kunststoff**  
**Tagliere sintetico**  
CHF 151.– 40.001.277.00**Nur für flächenbündigen Einbau erhältlich.**  
Disponibile solo per montaggio a filo top.**Inox Pad**  
CHF 125.– 40.001.138.00**Reinigungsset Easy Care**  
**Kit di pulizia Easy Care**  
CHF 29.–/N 40.001.509.00

 Varianten: Der Austausch von Zugknöpfen und/oder beschichteten Ventilbestandteilen erfolgt mittels Variantencode.  
Mehr Infos siehe Seite 395.  
Varianti: La sostituzione di pomoli e/o componenti piletta rivestiti avviene mediante codice variante.  
Per maggiori informazioni, vedere pag. 395.
**DEC-Beschichtung, schwarz matt**  
**Rivestimento a DEC, nero opaco**  
**3 1/2" TouchFlow Desino**  
CHF 140.–/F 40.002.789.02**DEC-Beschichtung, schwarz matt**  
**Rivestimento a DEC, nero opaco**  
**3 1/2" Raumspar Desino / Salvaspazio Desino**  
CHF 140.–/F 40.002.768.02**DEC-Beschichtung, schwarz matt**  
**Rivestimento a DEC, nero opaco**  
**3 1/2" Tipo Desino**  
CHF 140.–/F 40.002.996.02**Mehrpreis für beschichtete Ventilbestandteile**  
TouchFlow Desino, Raumspar Desino und Tipo Desino: Ablaufsieb Desino, Überlaufblende und Überlaufkappe**Sovrapprezzo per componenti piletta rivestiti**  
TouchFlow Desino, Salvaspazio Desino und Tipo Desino: griglietta per lo scarico Desino, mascherina e tappo di troppopieno

Preis CHF / Prezzo in CHF

Modell Modello	Material Materiale	Ventil sFlow, Typ M Piletta sFlow, tipo M	Artikel-Nr. N. di articolo	Beckentiefe Profondità	Exkl. MWST IVA esclusa	Inkl. MWST IVA inclusa	VRG TRA	
<b>Linero LIO CD 50F/17</b>	Cristadur, Puro	3 1/2" TouchFlow Desino	10.105.288.00 	165 mm	B	1647.–	1780.–	0.19
		3 1/2" Raumspar Desino Salvaspazio Desino	10.105.289.00 	165 mm	B	1437.–	1553.–	
		3 1/2" Tipo Desino	10.105.676.00 	165 mm	B	1437.–	1553.–	
	Cristadur, Stone	3 1/2" TouchFlow Desino	10.105.292.00 	165 mm	B	1647.–	1780.–	0.19
		3 1/2" Raumspar Desino Salvaspazio Desino	10.105.293.00 	165 mm	B	1437.–	1553.–	
		3 1/2" Tipo Desino	10.105.684.00 	165 mm	B	1437.–	1553.–	
	Cristadur, Polaris	3 1/2" TouchFlow Desino	10.105.290.00 	165 mm	B	1647.–	1780.–	0.19
		3 1/2" Raumspar Desino Salvaspazio Desino	10.105.291.00 	165 mm	B	1437.–	1553.–	
		3 1/2" Tipo Desino	10.105.688.00 	165 mm	B	1437.–	1553.–	

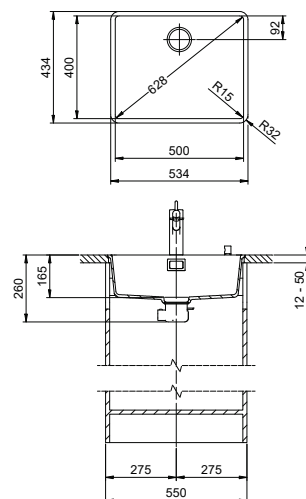

## Linero: LIO CDAB 50F/17 Black Edition

Randbreite 17 mm  
Larghezza bordo 17 mm**SCHOCK**  
CRISTADUR®

 Schwenkbare Überlaufkappe  
Placchetta di troppopieno a ribalta

 Obenliegendes Sieb  
Griglietta superiore

Zeichnung als pdf/dxf und Montageanleitung siehe:  
V. disegno in formato pdf/dxf e montaggio:  
suter.ch



**DEC-Beschichtung,  
schwarz matt**  
Rivestimento a DEC,  
nero opaco  
3 1/2" TouchFlow



**DEC-Beschichtung,  
schwarz matt**  
Rivestimento a DEC,  
nero opaco  
3 1/2" Raumspar/  
Salvaspazio



**DEC-Beschichtung,  
schwarz matt**  
Rivestimento a DEC,  
nero opaco  
3 1/2" Tipo

**Beschichtete Ventilbestandteile:  
im Preis inbegriffen**

TouchFlow, Raumspar und Tipo: Siebeinsatz, Überlaufblende und Überlaufkappe  
Raumspar: Bei der Black Edition ist der Zugknopf Advant (pulverbeschichtet, schwarz, matt) im Preis und Lieferumfang enthalten

**Componenti piletta rivestiti: incluso nel prezzo**

TouchFlow, Salvaspazio e Tipo: griglietta, mascherina e tappo di troppopieno  
Salvaspazio: La Black Edition comprende il pomolo Advant (rivestimento con polvere, nero, opaco) nel prezzo e nel corredo di fornitura



**Nur für flächenbündigen Einbau erhältlich.**  
Disponibile solo per montaggio a filo top.

**Flächenbündiger Einbau: Empfehlung zur Wahl der Arbeitsplatte**

Wir empfehlen den Einbau in Arbeitsplatten aus Keramik, Granit, Kunststein (z.B. Corian oder Varicor) oder Massivholz. Vom Einbau in beschichtete Spanplatten raten wir ab.

**Montaggio a filo top: Consiglio per la scelta del piano di lavoro**

Consigliamo il montaggio nei piani di lavoro in ceramica, granito, pietra artificiale (per es. Corian o Varicor) oppure in legno massiccio. Sconsigliamo la posa in pannelli di truciolato rivestiti.

**Preis CHF/Prezzo in CHF**

Modell Modello	Material Materiale	Ventil sFlow, Typ M Piletta sFlow, tipo M	Artikel-Nr. N. di articolo	Beckentiefe Profondità	Exkl. MWST IVA esclusa	Inkl. MWST IVA inclusa	VRG TRA
<b>Linero LIO CDAB 50F/17 Black Edition</b>		3 1/2" TouchFlow	10.105.677.50	165 mm	B 1675.-	1811.-	0.19
		3 1/2" Druckknopf Pulsante	10.106.252.50	165 mm	B 1522.-	1645.-	
		3 1/2" Raumspar Salvaspazio	10.105.678.50	165 mm	B 1477.-	1597.-	
		3 1/2" Tipo	10.105.679.50	165 mm	B 1436.-	1552.-	

# Linero: LIO CDAB 50F/17 Black Edition

Randbreite 17 mm  
Larghezza bordo 17 mm

**SCHOCK**  
CRISTADUR®

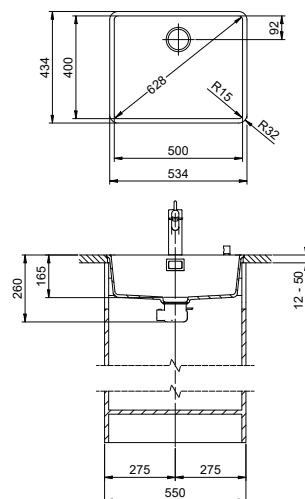

Schwenkbare Überlaufkappe  
Placchetta di troppopieno a ribalta

Desino: Verdeckter Ablauf mit untenliegendem Korb  
Desino: Scarico coperto con griglietta inferiore



Für TouchFlow Desino, Raumspars Desino und Tipo Desino  
Per TouchFlow Desino, Salvaspazio Desino e Tipo Desino

Für TouchFlow Desino, Raumspars Desino und Tipo Desino  
Per TouchFlow Desino, Salvaspazio Desino e Tipo Desino

Zeichnung als pdf / dxf und Montageanleitung siehe:  
V. disegno in formato pdf / dxf e montaggio:  
suter.ch



**DEC-Beschichtung, schwarz matt**  
Rivestimento a DEC, nero opaco  
3 1/2" TouchFlow Desino



**DEC-Beschichtung, schwarz matt**  
Rivestimento a DEC, nero opaco  
3 1/2" Raumspars Desino / Salvaspazio Desino



**DEC-Beschichtung, schwarz matt**  
Rivestimento a DEC, nero opaco  
3 1/2" Tipo Desino

**Beschichtete Ventilbestandteile: im Preis inbegriffen**  
TouchFlow Desino, Raumspars Desino und Tipo Desino: Ablaufsieb Desino, Überlaufblende und Überlaufkappe  
Raumspars Desino: Bei der Black Edition ist der Zugknopf Advant (pulverbeschichtet, schwarz, matt) im Preis und Lieferumfang enthalten

**Componenti piletta rivestiti: incluso nel prezzo**  
TouchFlow Desino, Salvaspazio Desino und Tipo Desino: griglietta per lo scarico Desino, mascherina e tappo di troppopieno  
Salvaspazio Desino: La Black Edition comprende il pomolo Advant (rivestimento con polvere, nero, opaco) nel prezzo e nel corredo di fornitura

**Nur für flächenbündigen Einbau erhältlich. Disponibile solo per montaggio a filo top.**

**Flächenbündiger Einbau: Empfehlung zur Wahl der Arbeitsplatte**  
Wir empfehlen den Einbau in Arbeitsplatten aus Keramik, Granit, Kunststein (z.B. Corian oder Varicor) oder Massivholz. Vom Einbau in beschichtete Spanplatten raten wir ab.

**Montaggio a filo top: Consiglio per la scelta del piano di lavoro**  
Consigliamo il montaggio nei piani di lavoro in ceramica, granito, pietra artificiale (per es. Corian o Varicor) oppure in legno massiccio. Sconsigliamo la posa in pannelli di truciolato rivestiti.

**Preis CHF/Prezzo in CHF**

Modell Modello	Material Materiale	Ventil sFlow, Typ M Piletta sFlow, tipo M	Artikel-Nr. N. di articolo	Beckentiefe Profondità	Exkl. MWST IVA esclusa	Inkl. MWST IVA inclusa	VRG TRA	
<b>Linero LIO CDAB 50F/17 Black Edition</b>	Cristadur, Puro	3 1/2" TouchFlow Desino	10.105.288.50	165 mm	B	1827.-	1975.-	0.19
		3 1/2" Raumspars Desino Salvaspazio Desino	10.105.289.50	165 mm	B	1617.-	1748.-	
		3 1/2" Tipo Desino	10.105.676.50	165 mm	B	1617.-	1748.-	

## Daneo: DAN CP 45F/17

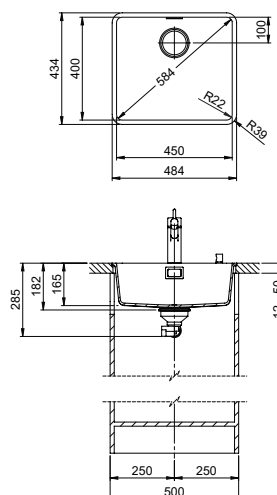
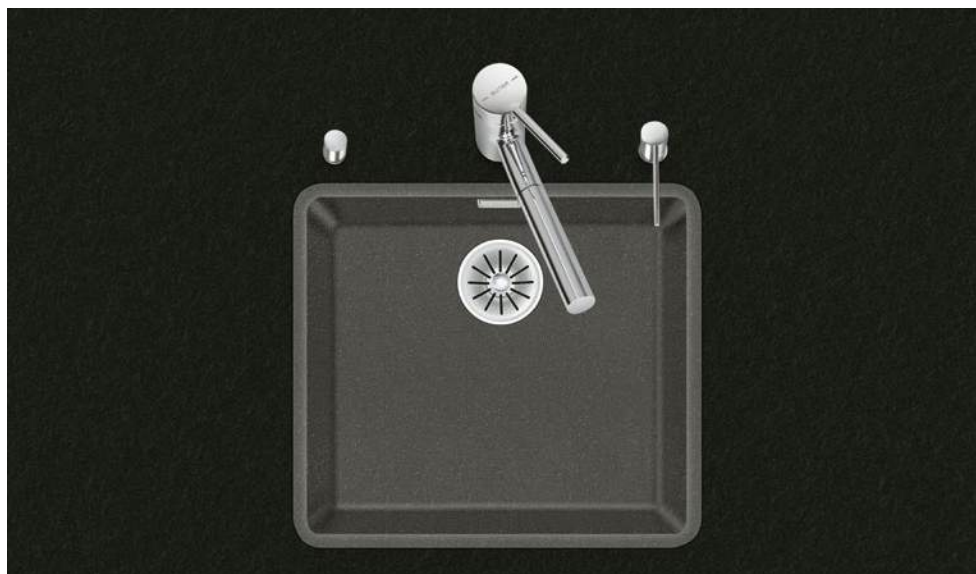
Randbreite 17 mm  
Larghezza bordo 17 mm**SCHOCK**  
CRISTALITE®

 Schwenkbare Überlaufkappe  
Placchetta di troppopieno a ribalta

15

 Obenliegendes Sieb  
Griglietta superiore

14

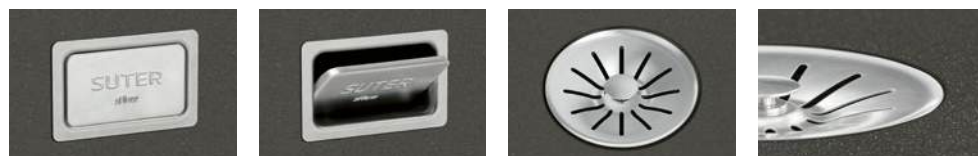

Zeichnung als pdf/dxf und Montageanleitung siehe:  
V. disegno in formato pdf/dxf e montaggio:  
suter.ch

## Optionales Zubehör/Accessori opzionali

312

**Nur für flächenbündigen Einbau erhältlich.**  
Disponibile solo per montaggio a filo top.

**Resteschale gelocht**  
**Vaschetta forato**  
CHF 106.– 40.000.912.00

**Resteschale ungelocht**  
**Vaschetta non forato**  
CHF 106.– 40.001.289.00

**Schneidebrett aus Glas**  
**Tagliere in vetro**  
CHF 151.– 40.000.909.00

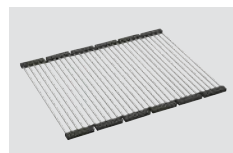
**Schneidebrett aus Kunststoff**  
**Tagliere sintetico**  
CHF 151.– 40.001.277.00

**Inox Pad**  
CHF 125.– 40.001.138.00

**Reinigungsset Easy Care**  
**Kit di pulizia Easy Care**  
CHF 29.–/N 40.001.509.00

Varianten: Der Austausch von Zugknöpfen und/oder beschichteten Ventilbestandteilen erfolgt mittels Variantencode. Mehr Infos siehe Seite 395.  
Varianti: La sostituzione di pomoli e/o componenti piletta rivestiti avviene mediante codice variante. Per maggiori informazioni, vedere pag. 395.

**DEC-Beschichtung, schwarz matt**  
**Rivestimento a DEC, nero opaco**  
**3 ½" TouchFlow**  
CHF 197.–/F 40.002.559.02















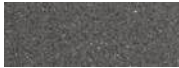















**DEC-Beschichtung, schwarz matt**  
**Rivestimento a DEC, nero opaco**  
**3 ½" Raumspar / Salvaspazio**  
CHF 197.–/F 40.002.560.02

**DEC-Beschichtung, schwarz matt**  
**Rivestimento a DEC, nero opaco**  
**3 ½" Tipo**  
CHF 197.–/F 40.002.561.02

**Mehrpreis für beschichtete Ventilbestandteile**  
TouchFlow und Raumspar: Stößel, Ventilkelch, Siebeinsatz, Überlaufblende und Überlaufkappe  
Tipo: Tipo-Siebstopfen, Ventilkelch, Überlaufblende und Überlaufkappe

**Sovrapprezzo per componenti piletta rivestiti**  
TouchFlow e Salvaspazio: tappo, tazza, griglietta, mascherina e tappo di troppopieno.  
Tipo: griglietta Tipo, tazza, mascherina e tappo di troppopieno.

Preis CHF / Prezzo in CHF

Modell Modello	Material Materiale	Ventil Piletta	Artikel-Nr. N. di articolo	Beckentiefe Profondità	Exkl. MWST IVA esclusa	Inkl. MWST IVA inclusa	VRG TRA	
<b>Daneo DAN CP 45F/17</b>	Cristalite Plus, Nero 	3 1/2" TouchFlow	10.104.680.00 	165 mm	B	1341.–	1450.–	0.19
		3 1/2" Raumspar Salvaspazio	10.104.681.00 	165 mm	B	1143.–	1236.–	
		3 1/2" Tipo	10.104.682.00 	165 mm	B	1102.–	1191.–	
	Cristalite Plus, Asphalt 	3 1/2" TouchFlow	10.104.695.00 	165 mm	B	1341.–	1450.–	0.19
		3 1/2" Raumspar Salvaspazio	10.104.696.00 	165 mm	B	1143.–	1236.–	
		3 1/2" Tipo	10.104.697.00 	165 mm	B	1102.–	1191.–	
	Cristalite Plus, Mocha 	3 1/2" TouchFlow	10.104.689.00  	165 mm	B	1341.–	1450.–	0.19
		3 1/2" Raumspar Salvaspazio	10.104.690.00  	165 mm	B	1143.–	1236.–	
		3 1/2" Tipo	10.104.691.00  	165 mm	B	1102.–	1191.–	
	Cristalite Plus, Croma 	3 1/2" TouchFlow	10.104.686.00  	165 mm	B	1341.–	1450.–	0.19
		3 1/2" Raumspar Salvaspazio	10.104.687.00  	165 mm	B	1143.–	1236.–	
		3 1/2" Tipo	10.104.688.00  	165 mm	B	1102.–	1191.–	
	Cristalite Plus, Everest 	3 1/2" TouchFlow	10.104.692.00 	165 mm	B	1341.–	1450.–	0.19
		3 1/2" Raumspar Salvaspazio	10.104.693.00 	165 mm	B	1143.–	1236.–	
		3 1/2" Tipo	10.104.694.00 	165 mm	B	1102.–	1191.–	
Cristalite Plus, Superwhite/Alpina 	3 1/2" TouchFlow	10.104.683.00 	165 mm	B	1341.–	1450.–	0.19	
	3 1/2" Raumspar Salvaspazio	10.104.684.00 	165 mm	B	1143.–	1236.–		
	3 1/2" Tipo	10.104.685.00 	165 mm	B	1102.–	1191.–		

IF-Spülen  
IF-Lavelli



Daneo: DAN CP 45F/17

## Daneo: DAN CP 50F/17

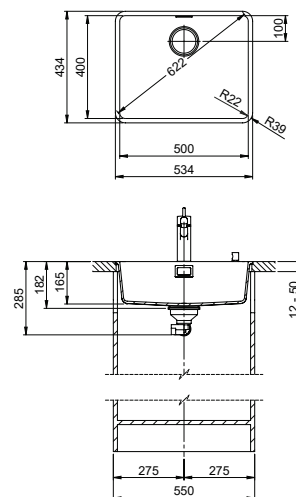
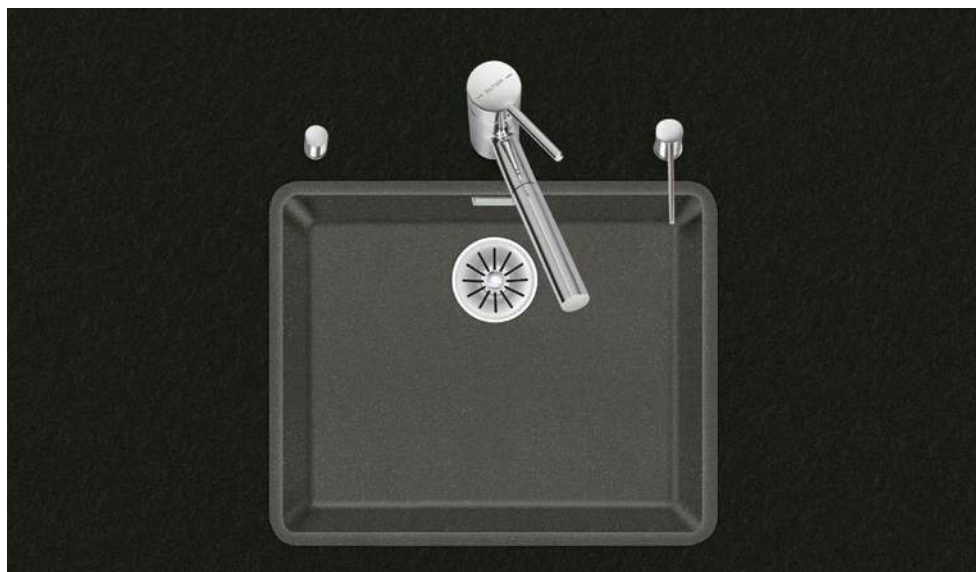
Randbreite 17 mm  
Larghezza bordo 17 mmSCHOCK  
CRISTALITE®

 Schwenkbare Überlaufkappe  
Placchetta di troppopieno a ribalta

15

 Obenliegendes Sieb  
Griglietta superiore

14

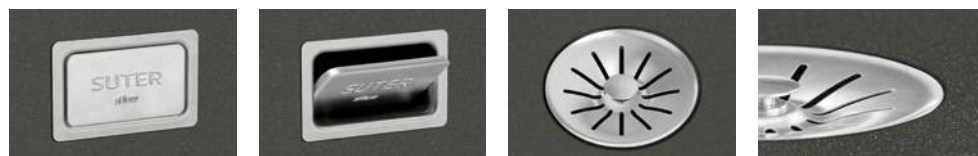

Zeichnung als pdf / dxf und Montageanleitung siehe:  
V. disegno in formato pdf / dxf e montaggio:  
suter.ch

## Optionales Zubehör/Accessori opzionali

312

 Nur für flächenbündigen Einbau erhältlich.  
Disponibile solo per montaggio a filo top.

**Resteschale gelocht**  
**Vaschetta forato**  
CHF 106.– 40.000.912.00

**Resteschale ungelocht**  
**Vaschetta non forato**  
CHF 106.– 40.001.289.00

**Schneidebrett aus Glas**  
**Tagliere in vetro**  
CHF 151.– 40.000.909.00

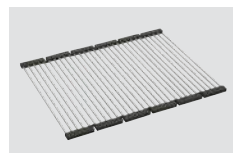
**Schneidebrett aus Kunststoff**  
**Tagliere sintetico**  
CHF 151.– 40.001.277.00

**Inox Pad**  
CHF 125.– 40.001.138.00

**Reinigungsset Easy Care**  
**Kit di pulizia Easy Care**  
CHF 29.–/N 40.001.509.00

Varianten: Der Austausch von Zugknöpfen und/oder beschichteten Ventilbestandteilen erfolgt mittels Variantencode. Mehr Infos siehe Seite 395.  
Varianti: La sostituzione di pomoli e/o componenti piletta rivestiti avviene mediante codice variante. Per maggiori informazioni, vedere pag. 395.

**DEC-Beschichtung, schwarz matt**  
**Rivestimento a DEC, nero opaco**  
**3 ½" TouchFlow**  
CHF 197.–/F 40.002.559.02















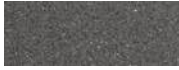

**DEC-Beschichtung, schwarz matt**  
**Rivestimento a DEC, nero opaco**  
**3 ½" Raumspar / Salvaspazio**  
CHF 197.–/F 40.002.560.02

**DEC-Beschichtung, schwarz matt**  
**Rivestimento a DEC, nero opaco**  
**3 ½" Tipo**  
CHF 197.–/F 40.002.561.02

**Mehrpreis für beschichtete Ventilbestandteile**  
TouchFlow und Raumspar: Stößel, Ventilkelch, Siebeinsatz, Überlaufblende und Überlaufkappe  
Tipo: Tipo-Siebstopfen, Ventilkelch, Überlaufblende und Überlaufkappe

**Sovrapprezzo per componenti piletta rivestiti**  
TouchFlow e Salvaspazio: tappo, tazza, griglietta, mascherina e tappo di troppopieno.  
Tipo: griglietta Tipo, tazza, mascherina e tappo di troppopieno.

Preis CHF / Prezzo in CHF

Modell Modello	Material Materiale	Ventil Piletta	Artikel-Nr. N. di articolo	Beckentiefe Profondità	Exkl. MWST IVA esclusa	Inkl. MWST IVA inclusa	VRG TRA	
<b>Daneo DAN CP 50F/17</b>	Cristalite Plus, Nero 	3 1/2" TouchFlow	10.104.698.00 	165 mm	B	1349.–	1458.–	0.19
		3 1/2" Raumspar Salvaspazio	10.104.699.00 	165 mm	B	1151.–	1244.–	
		3 1/2" Tipo	10.104.700.00 	165 mm	B	1110.–	1200.–	
	Cristalite Plus, Asphalt 	3 1/2" TouchFlow	10.104.713.00 	165 mm	B	1349.–	1458.–	0.19
		3 1/2" Raumspar Salvaspazio	10.104.714.00 	165 mm	B	1151.–	1244.–	
		3 1/2" Tipo	10.104.715.00 	165 mm	B	1110.–	1200.–	
	Cristalite Plus, Everest 	3 1/2" TouchFlow	10.104.710.00 	165 mm	B	1349.–	1458.–	0.19
		3 1/2" Raumspar Salvaspazio	10.104.711.00 	165 mm	B	1151.–	1244.–	
		3 1/2" Tipo	10.104.712.00 	165 mm	B	1110.–	1200.–	
	Cristalite Plus, Superwhite/Alpina 	3 1/2" TouchFlow	10.104.701.00 	165 mm	B	1349.–	1458.–	0.19
		3 1/2" Raumspar Salvaspazio	10.104.702.00 	165 mm	B	1151.–	1244.–	
		3 1/2" Tipo	10.104.703.00 	165 mm	B	1110.–	1200.–	



Daneo: DAN CP 50F/17

## Daneo: DAN CP 55F/17

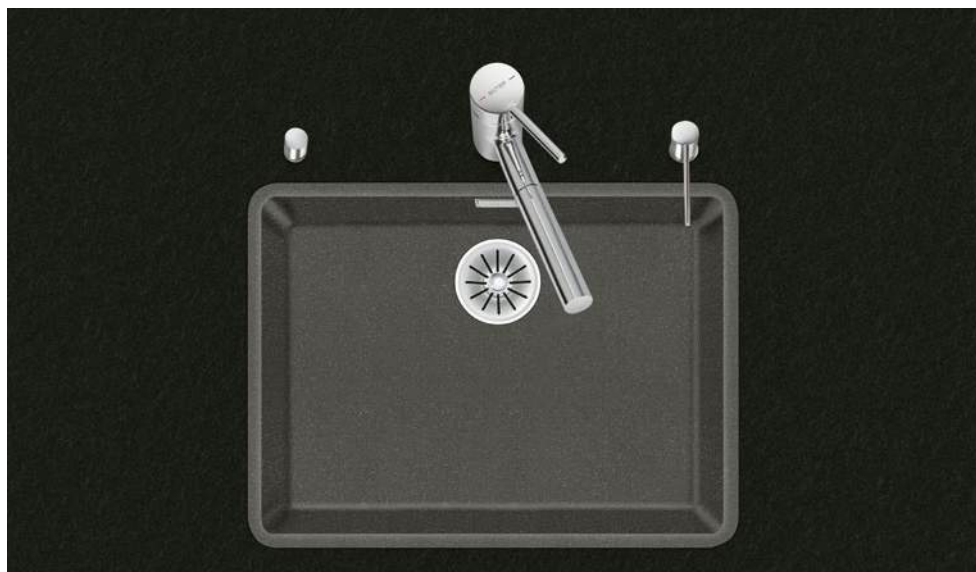
Randbreite 17 mm  
Larghezza bordo 17 mm**SCHOCK**  
CRISTALITE<sup>+</sup>

 Schwenkbare Überlaufkappe  
Placchetta di troppopieno a ribalta

 Obenliegendes Sieb  
Griglietta superiore

14

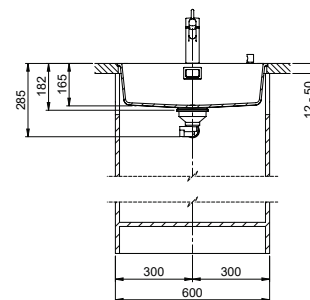
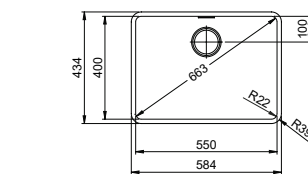

Zeichnung als pdf / dxf und Montageanleitung siehe:  
V. disegno in formato pdf / dxf e montaggio:  
suter.ch

## Optionales Zubehör/Accessori opzionali

312

**Nur für flächenbündigen Einbau erhältlich.**  
Disponibile solo per montaggio a filo top.

**Resteschale gelocht**  
**Vaschetta forato**  
CHF 106.– 40.000.912.00

**Resteschale ungelocht**  
**Vaschetta non forato**  
CHF 106.– 40.001.289.00

**Schneidebrett aus Glas**  
**Tagliere in vetro**  
CHF 151.– 40.000.909.00

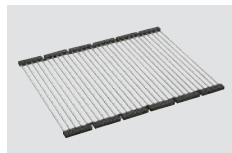
**Schneidebrett aus Kunststoff**  
**Tagliere sintetico**  
CHF 151.– 40.001.277.00

**Inox Pad**  
CHF 125.– 40.001.138.00

**Reinigungsset Easy Care**  
**Kit di pulizia Easy Care**  
CHF 29.–/N 40.001.509.00

**Flächenbündiger Einbau: Empfehlung zur Wahl der Arbeitsplatte**

Wir empfehlen den Einbau in Arbeitsplatten aus Keramik, Granit, Kunststein (z.B. Corian oder Varicor) oder Massivholz. Vom Einbau in beschichtete Spanplatten raten wir ab.

**Montaggio a filo top: Consiglio per la scelta del piano di lavoro**

Consigliamo il montaggio nei piani di lavoro in ceramica, granito, pietra artificiale (per es. Corian o Varicor) oppure in legno massiccio. Sconsigliamo la posa in pannelli di truciolato rivestiti.

Varianten: Der Austausch von Zugknöpfen und/oder beschichteten Ventilbestandteilen erfolgt mittels Variantencode. Mehr Infos siehe Seite 395.

Varianti: La sostituzione di pomoli e/o componenti piletta rivestiti avviene mediante codice variante. Per maggiori informazioni, vedere pag. 395.

**DEC-Beschichtung, schwarz matt**  
**Rivestimento a DEC, nero opaco**  
**3 ½" TouchFlow**  
CHF 197.–/F 40.002.559.02

**DEC-Beschichtung, schwarz matt**  
**Rivestimento a DEC, nero opaco**  
**3 ½" Raumspas / Salvaspazio**  
CHF 197.–/F 40.002.560.02















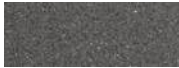















**DEC-Beschichtung, schwarz matt**  
**Rivestimento a DEC, nero opaco**  
**3 ½" Tipo**  
CHF 197.–/F 40.002.561.02

**Mehrpreis für beschichtete Ventilbestandteile**  
TouchFlow und Raumspas: Stößel, Ventilkelch, Siebeinsatz, Überlaufblende und Überlaufkappe  
Tipo: Tipo-Siebstopfen, Ventilkelch, Überlaufblende und Überlaufkappe

**Sovrapprezzo per componenti piletta rivestiti**

TouchFlow und Salvaspazio: tappo, tazza, griglietta, mascherina e tappo di troppopieno.  
Tipo: griglietta Tipo, tazza, mascherina e tappo di troppopieno.

Preis CHF / Prezzo in CHF

Modell Modello	Material Materiale	Ventil Piletta	Artikel-Nr. N. di articolo	Beckentiefe Profondità	Exkl. MWST IVA esclusa	Inkl. MWST IVA inclusa	VRG TRA	
<b>Daneo DAN CP 55F/17</b>	Cristalite Plus, Nero 	3 1/2" TouchFlow	10.104.716.00 	165 mm	B	1583.–	1711.–	0.19
		3 1/2" Raumspar Salvaspazio	10.104.717.00 	165 mm	B	1385.–	1497.–	
		3 1/2" Tipo	10.104.718.00 	165 mm	B	1344.–	1453.–	
	Cristalite Plus, Asphalt 	3 1/2" TouchFlow	10.104.731.00 	165 mm	B	1583.–	1711.–	0.19
		3 1/2" Raumspar Salvaspazio	10.104.732.00 	165 mm	B	1385.–	1497.–	
		3 1/2" Tipo	10.104.733.00 	165 mm	B	1344.–	1453.–	
	Cristalite Plus, Mocha 	3 1/2" TouchFlow	10.104.725.00  	165 mm	B	1583.–	1711.–	0.19
		3 1/2" Raumspar Salvaspazio	10.104.726.00  	165 mm	B	1385.–	1497.–	
		3 1/2" Tipo	10.104.727.00  	165 mm	B	1344.–	1453.–	
	Cristalite Plus, Croma 	3 1/2" TouchFlow	10.104.722.00  	165 mm	B	1583.–	1711.–	0.19
		3 1/2" Raumspar Salvaspazio	10.104.723.00  	165 mm	B	1385.–	1497.–	
		3 1/2" Tipo	10.104.724.00  	165 mm	B	1344.–	1453.–	
	Cristalite Plus, Everest 	3 1/2" TouchFlow	10.104.728.00 	165 mm	B	1583.–	1711.–	0.19
		3 1/2" Raumspar Salvaspazio	10.104.729.00 	165 mm	B	1385.–	1497.–	
		3 1/2" Tipo	10.104.730.00 	165 mm	B	1344.–	1453.–	
Cristalite Plus, Superwhite/Alpina 	3 1/2" TouchFlow	10.104.719.00 	165 mm	B	1583.–	1711.–	0.19	
	3 1/2" Raumspar Salvaspazio	10.104.720.00 	165 mm	B	1385.–	1497.–		
	3 1/2" Tipo	10.104.721.00 	165 mm	B	1344.–	1453.–		

IF-Spülen  
IF-Lavelli



Daneo: DAN CP 55F/17



Zaros: ZOS 90



Zaros: ZOS 100

**Sortiment nach Unterschrankmassen**

Assortimento per dimensioni di base **296**

**Edelstahl / Acciaio inox**

**Silver Star**

SIL 50 **298**

**Zaros**

ZOS 75 **299**

ZOS 90 **300**

ZOS 100 **301**

**Comfort**

COM 34 **302**

COM 40 **303**

C 75 **304**

MCOM 90 **305**

**Spezialeinleger / Lavello da incasso speciale**

**Rund**

R 44B **306**

**Granit (Cristalite Plus)**

Granito (Cristalite Plus)

**Nemo**

NEM N 100 **307**

**Primus**

PRI D 100 **308**

PRI D 100L **309**

**Montagematerial / Materiale per il montaggio**



Holz-Klick\* /  
Attacco per legno\*  
40.000.351.00





Stein-Klick\* /  
Attacco per pietra\*  
40.000.435.00



Befestigungsklammern für Einlege-  
Spülen und Flächenbündige-Spülen/  
Staffe di fissaggio per lavelli a filo top e  
lavelli sopraiano  
40.002.041.00

Im Lieferumfang enthalten / Materiale per il montaggio incluso nella fornitura

\*  Bitte bei Spülen mit diesem Symbol den gewünschten Typ angeben.

\*  Per i lavelli recanti questo simbolo si prega di indicare il modello richiesto.

## Sortiment nach Unterschrankmassen / Assortimento per dimensioni di base

40cm

45cm

Silver Star

Zaros



Zaros: ZOS 75

299

Comfort



Comfort: COM 34

302



Comfort: COM 40

303



Comfort: C 75

304

Primus / Nemo



Primus: PRI D 100

308

Einzel-Becken  
Lavelli a vasca singola

Rund: R 44B

306

Auffrisch- und Pflegeservice  
 Mehr Infos siehe Seite 25  
 Servizio di pulizia e manutenzione  
 Per maggiori informazioni, vedere pag. 25

50cm

55cm

60cm



Silver Star: SIL 50



Zaros: ZOS 90



Zaros: ZOS 100



Nemo: NEM N 100



Primus: PRI D 100L



# Silver Star: SIL 50

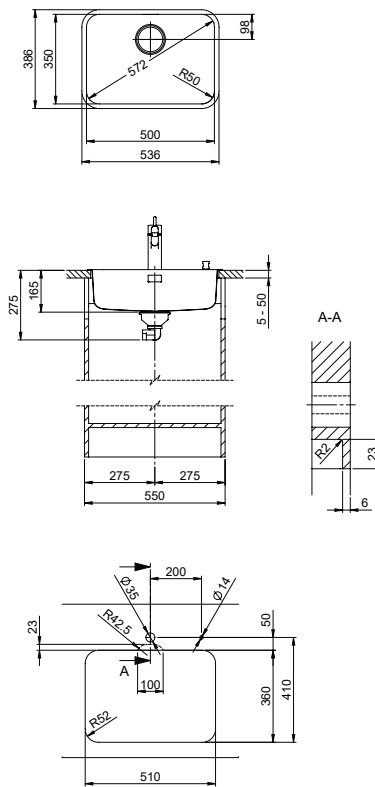

Verdeckter Überlauf  
Troppieno coperto

Obenliegendes Sieb  
Griglietta superiore



## Optionales Zubehör / Accessori opzionali



**Resteschale** gelocht  
**Vaschetta** forato  
CHF 106.- 40.000.916.00

Zeichnung als pdf / dxf und Montageanleitung siehe:  
V. disegno in formato pdf / dxf e montaggio:  
suter.ch

**Wählen Sie den Oberflächenfinish:**  
In den Ausführungen glanz und matt erhältlich.  
**Scegliete la finitura:**  
Disponibile nelle finiture lucido e opaco.

Varianten: Der Austausch von Zugknöpfen erfolgt mittels Variantencode. Mehr Infos siehe Seite 395.  
Varianti: La sostituzione di pomoli avviene mediante codice variante. Per maggiori informazioni, vedere pag. 395.

**Preis CHF / Prezzo in CHF**

Modell Modello	Material Materiale	Ventil Piletta	Artikel-Nr. N. di articolo	Beckentiefe Profondità	Exkl. MWST IVA esclusa	Inkl. MWST IVA inclusa
<b>Silver Star SIL 50</b>	Edelstahl, matt Acciaio inox, opaco	18/10 3 1/2" Raumsparsalvaspazio	10.103.956.00	165 mm	A 812.-	878.-
		3 1/2" Tipo	10.103.957.00	165 mm	A 771.-	833.-
	Edelstahl, glanz Acciaio inox, lucido	18/10 3 1/2" Raumsparsalvaspazio	10.103.953.00	165 mm	A 812.-	878.-
		3 1/2" Tipo	10.103.954.00	165 mm	A 771.-	833.-

Zaros: ZOS 75

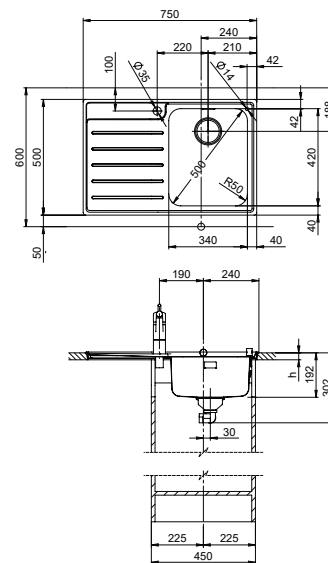

Verdeckter Überlauf  
Troppieno coperto

Obenliegendes Sieb  
Griglietta superiore



Aussenmasse /  
Dimensioni esterne:  
750 x 500 mm  
Ausschnitt / Intaglio:  
734 x 484 +2 / -0 mm  
R = ca. 5 mm  
h = >28 mm (Holz / Legno)  
h = 28 – 32 mm (Stein / Pietra)

Optionales Zubehör / Accessori opzionali

312



**Resteschale** gelocht  
**Vaschetta** forato  
CHF 42.– 40.001.004.00

**Resteschale** gelocht  
**Vaschetta** forato  
CHF 106.– 40.000.971.00

**Schneidebrett** aus Glas  
**Tagliere** in vetro  
CHF 151.– 40.000.915.00

Zeichnung als pdf / dxf und Montageanleitung siehe:  
V. disegno in formato pdf / dxf e montaggio:  
suter.ch

Varianten: Der Austausch von Zugknöpfen erfolgt mittels Variantencode. Mehr Infos siehe Seite 395.  
Varianti: La sostituzione di pomoli avviene mediante codice variante. Per maggiori informazioni, vedere pag. 395.

Preis CHF / Prezzo in CHF

Modell Modello	Material Materiale	Ventil Piletta	Artikel-Nr. N. di articolo	Tropfteil Scolatoio	Exkl. MWST IVA esclusa	Inkl. MWST IVA inclusa
<b>Zaros ZOS 75</b>	Edelstahl, glanz Acciaio inox, lucido	3 1/2" Raumspär Salvaspazio	10.103.110.00	Links / Sinistra	A	925.–
			10.103.111.00	Rechts / Destra		
		3 1/2" Tipo	10.103.112.00	Links / Sinistra	A	765.–
			10.103.113.00	Rechts / Destra		
		1 1/2" Standrohr Con tubo	10.103.108.00	Links / Sinistra	A	719.–
			10.103.109.00	Rechts / Destra		

Zaros: ZOS 90

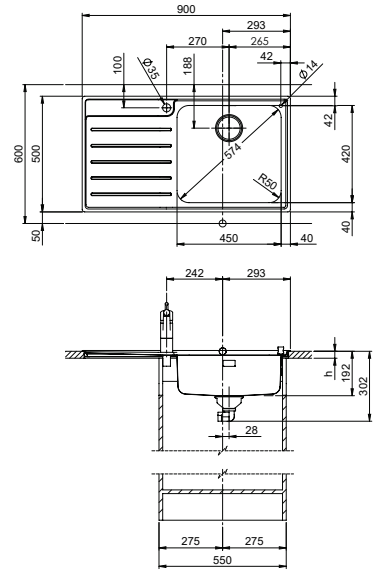

Verdeckter Überlauf  
Troppieno coperto

Obenliegendes Sieb  
Griglietta superiore



Aussenmasse /  
Dimensioni esterne:  
900 x 500 mm  
Ausschnitt / Intaglio:  
884 x 484 +2 / -0 mm  
R = ca. 5 mm  
h = >28 mm (Holz / Legno)  
h = 28 - 32 mm (Stein / Pietra)

Optionales Zubehör / Accessori opzionali



**Resteschale gelocht**  
**Vaschetta forato**  
CHF 106.- 40.000.914.00

**Resteschale ungelocht**  
**Vaschetta non forato**  
CHF 106.- 40.001.290.00

**Schneidebrett aus Glas**  
**Tagliere in vetro**  
CHF 151.- 40.000.915.00

Zeichnung als pdf / dxf und Montageanleitung siehe:  
V. disegno in formato pdf / dxf e montaggio:  
suter.ch

Varianten: Der Austausch von Zugknöpfen erfolgt mittels Variantencode. Mehr Infos siehe Seite 395.  
Varianti: La sostituzione di pomoli avviene mediante codice variante. Per maggiori informazioni, vedere pag. 395.

Preis CHF / Prezzo in CHF

Modell Modello	Material Materiale	Ventil Piletta	Artikel-Nr. N. di articolo	Tropfteil Scolatoio	Exkl. MWST IVA esclusa	Inkl. MWST IVA inclusa
<b>Zaros ZOS 90</b>	Edelstahl, glanz Acciaio inox, lucido	3 1/2" Raumspar Salvaspazio	10.103.126.00	Links / Sinistra	A 1030.-	1113.-
			10.103.127.00	Rechts / Destra		
		3 1/2" Tipo	10.103.128.00	Links / Sinistra	A 902.-	975.-
			10.103.129.00	Rechts / Destra		

# Zaros: ZOS 100

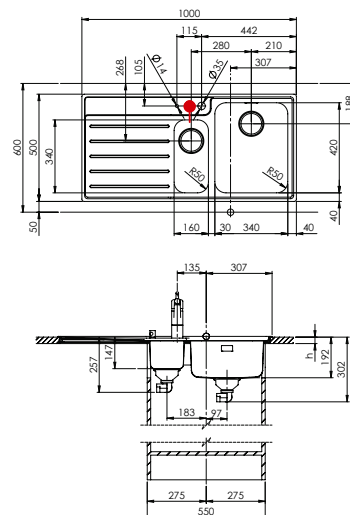

Verdeckter Überlauf  
Troppieno coperto

Obenliegendes Sieb  
Griglietta superiore

14



Aussenmasse /  
Dimensioni esterne:  
1000 x 500 mm  
Ausschnitt / Intaglio:  
984 x 484 +2/-0 mm  
R = ca. 5 mm  
h = >28 mm (Holz / Legno)  
h = 28 - 32 mm (Stein / Pietra)

## Inklusives Zubehör / Accessori inclusi



CHF42.- 40.001.004.00

Mehrpreis für Resteschale aus Edelstahl CHF 64.-  
Sovrapprezzo per vaschetta in acciaio inox CHF 64.-

Zeichnung als pdf / dxf und Montageanleitung siehe:  
V. disegno in formato pdf / dxf e montaggio:  
suter.ch

## Optionales Zubehör / Accessori opzionali

312



**Resteschale** gelocht  
**Vaschetta** forato  
CHF 106.- 40.000.971.00



**Schneidebrett** aus Glas  
**Tagliere** in vetro  
CHF 151.- 40.000.915.00

Varianten: Der Austausch von Zugknöpfen erfolgt mittels Variantencode. Mehr Infos siehe Seite 395.  
Varianti: La sostituzione di pomoli avviene mediante codice variante. Per maggiori informazioni, vedere pag. 395.

## Preis CHF / Prezzo in CHF

Modell Modello	Material Materiale	Ventil Piletta	Artikel-Nr. N. di articolo	Tropfteil Scolatoio	Exkl. MWST IVA esclusa	Inkl. MWST IVA inclusa
<b>Zaros ZOS 100</b>	Edelstahl, glanz Acciaio inox, lucido	3 1/2" Raumspar Salvaspazio	10.103.116.00	Links / Sinistra	A 1271.-	1374.-
			10.103.117.00	Rechts / Destra		
		3 1/2" Tipo	10.103.118.00	Links / Sinistra	A 1132.-	1224.-
			10.103.119.00	Rechts / Destra		

Comfort: COM 34

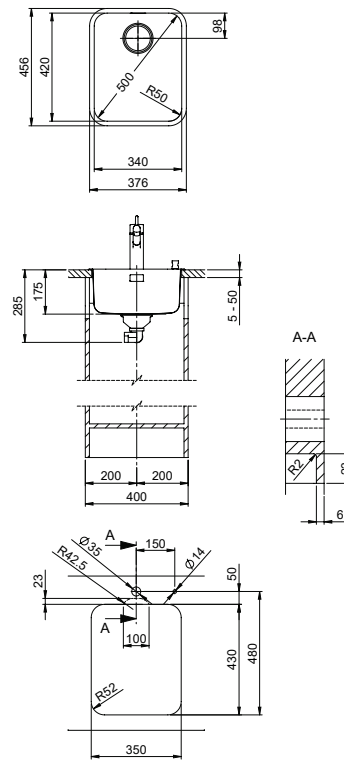

Verdeckter Überlauf  
Trooppieno coperto

15 Obenliegendes Sieb  
Griglietta superiore

14



Optionales Zubehör / Accessori opzionali

312



**Resteschale** gelocht  
**Vaschetta** forato  
CHF 42.- 40.001.004.00

**Resteschale** gelocht  
**Vaschetta** forato  
CHF 106.- 40.000.971.00

**Schneidebrett** aus Glas  
**Tagliere** in vetro  
CHF 151.- 40.000.915.00

**Inox Pad**  
CHF 125.- 40.001.138.00

Zeichnung als pdf / dxf und Montageanleitung siehe:  
V. disegno in formato pdf / dxf e montaggio:  
suter.ch

Varianten: Der Austausch von Zugknöpfen erfolgt mittels Variantencode. Mehr Infos siehe Seite 395.  
Varianti: La sostituzione di pomoli avviene mediante codice variante. Per maggiori informazioni, vedere pag. 395.

Preis CHF / Prezzo in CHF

Modell Modello	Material Materiale	Ventil Piletta	Artikel-Nr. N. di articolo	Beckentiefe Profondità	Exkl. MWST IVA esclusa	Inkl. MWST IVA inclusa
Comfort COM 34	Edelstahl, glanz Acciaio inox, lucido	18/10 3 1/2" Raumspaar Salvaspazio	10.102.726.00	175 mm	A 871.-	942.-
		3 1/2" Tipo	10.103.102.00	175 mm	A 830.-	897.-

Comfort: COM 40

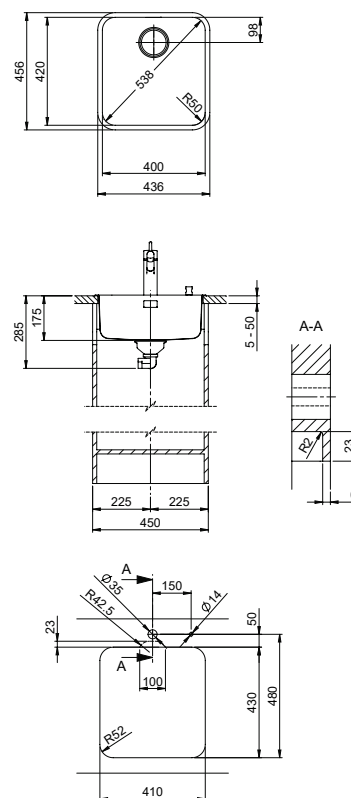

Verdeckter Überlauf  
Trooppieno coperto

Obenliegendes Sieb  
Griglietta superiore



Optionales Zubehör / Accessori opzionali



**Resteschale gelocht**  
Vaschetta forato  
CHF 106.- 40.000.914.00

**Resteschale ungelocht**  
Vaschetta non forato  
CHF 106.- 40.001.290.00

**Schneidebrett aus Glas**  
Tagliere in vetro  
CHF 151.- 40.000.915.00

**Holz-Schneidebrett aus Nussbaum**  
Tagliere in legno di noce  
CHF 151.- 40.001.147.00

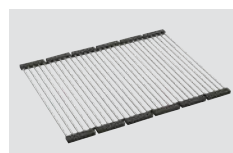

**Inox Pad**  
CHF 125.- 40.001.138.00

Zeichnung als pdf / dxf und Montageanleitung siehe:  
V. disegno in formato pdf / dxf e montaggio:  
suter.ch

Varianten: Der Austausch von Zugknöpfen erfolgt mittels Variantencode. Mehr Infos siehe Seite 395.  
Varianti: La sostituzione di pomoli avviene mediante codice variante. Per maggiori informazioni, vedere pag. 395.

Preis CHF / Prezzo in CHF

Modell Modello	Material Materiale	Ventil Piletta	Artikel-Nr. N. di articolo	Beckentiefe Profondità	Exkl. MWST IVA esclusa	Inkl. MWST IVA inclusa
Comfort COM 40	Edelstahl, glanz Acciaio inox, lucido	3 1/2" Raumspar Salvaspazio	10.103.204.00	175 mm	A	908.- 982.-
		3 1/2" Tipo	10.103.203.00	175 mm	A	867.- 937.-

## Comfort: C 75



1 1/2" Standrohr  
Con tubo ◀ 40 ▶

3 1/2" Raumspar  
Salvaspazio ◀ 45 ▶

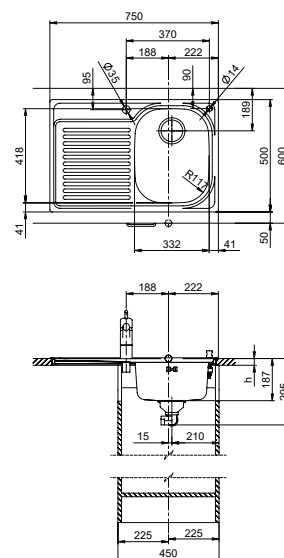

Aussenmasse /  
Dimensioni esterne:  
750 x 500 mm

Ausschnitt / Intaglio:  
734 x 484 +2 / -0 mm  
R = ca. 5 mm  
h = >28 mm (Holz / Legno),  
h = 28 - 32 mm (Stein / Pietra)

Zeichnung als pdf / dxf und Montageanleitung siehe:  
V. disegno in formato pdf / dxf e montaggio:  
suter.ch

! Varianten: Der Austausch von Zugknöpfen erfolgt mittels Variantencode. Mehr Infos siehe Seite 395.  
Varianti: La sostituzione di pomoli avviene mediante codice variante. Per maggiori informazioni, vedere pag. 395.

Preis CHF / Prezzo in CHF

Modell Modello	Material Materiale	Ventil Piletta	Artikel-Nr. N. di articolo	Tropfteil Scolatoio	Exkl. MWST IVA esclusa	Inkl. MWST IVA inclusa
Comfort C 75	Edelstahl, glanz Acciaio inox, lucido	3 1/2" Raumspar Salvaspazio	10.100.016.00	Links / Sinistra	A 911.-	985.-
			10.100.017.00	Rechts / Destra		
		1 1/2" Standrohr Con tubo	10.100.014.00	Links / Sinistra	A 735.-	795.-
			10.100.015.00	Rechts / Destra		

**Comfort: MCOM 90** Spezialeinleger / Lavello da incasso speciale

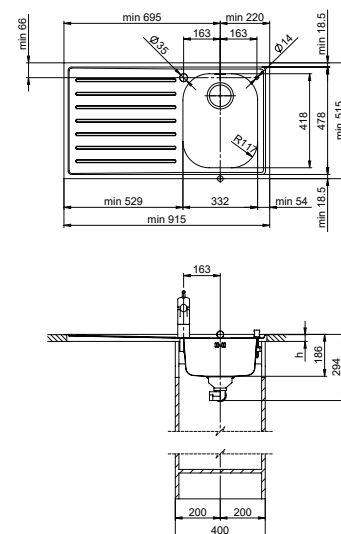

Dieser Spezialeinleger kann ohne Mehrpreis um die angegebenen Masse frei erweitert werden.  
Le dimensioni di questo lavello da incasso speciale possono essere liberamente aumentate, senza sovrapprezzo, fino alle misure indicate.



Ausschnitt / Intaglio:  
min. 890 x 490 +2/-0 mm,  
R = max. 5 mm

**i** Bei der Bestellung des Spezialeinlegers müssen die erforderlichen Aussenmasse mittels einer Skizze definiert werden.  
In sede di ordine di un lavello speciale è necessario fornire uno schizzo in cui siano precisate le misure esterne richieste.

**!** Varianten: Der Austausch von Zugknöpfen erfolgt mittels Variantencode. Mehr Infos siehe Seite 395.  
Varianti: La sostituzione di pomoli avviene mediante codice variante. Per maggiori informazioni, vedere pag. 395.

**Preis CHF / Prezzo in CHF**

Modell Modello	Material Materiale	Ventil Piletta	Artikel-Nr. N. di articolo	Beckentiefe Profondità	Tropfteil Scolatoio	Exkl. MWST IVA esclusa	Inkl. MWST IVA inclusa
<b>Comfort MCOM 90*</b> Spezialeinleger Lavello da incasso speciale	Edelstahl, glanz Acciaio inox, lucido	18/10	3 1/2" Raumspar Salvaspazio	29.001.253.00	Links / Sinistra	D 2008.-	2171.-
				29.001.254.00	Rechts / Destra		

\* Wird nur auf Wunsch hergestellt – 3 Wochen Lieferfrist (kein Lagerartikel) / Fabbricazione solo su richiesta con termine di consegna di 3 settimane (articolo non a magazzino)

## Rund: R 44B



Obenliegendes Sieb  
Griglietta superiore

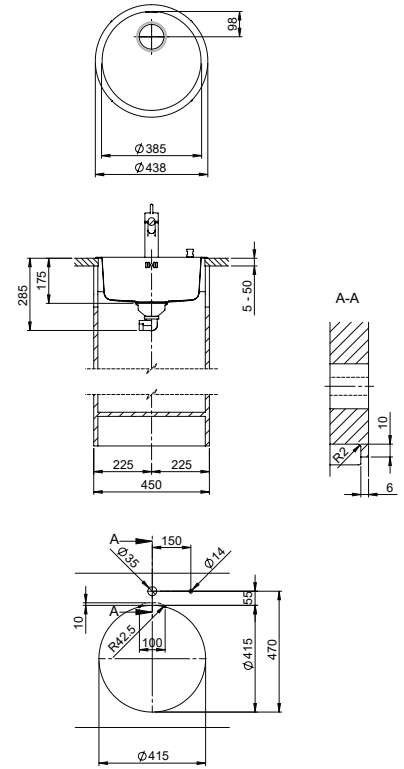

Zeichnung als pdf / dxf und Montageanleitung siehe:  
V. disegno in formato pdf / dxf e montaggio:  
suter.ch

**!** Varianten: Der Austausch von Zugknöpfen erfolgt mittels Variantencode. Mehr Infos siehe Seite 395.  
Varianti: La sostituzione di pomoli avviene mediante codice variante. Per maggiori informazioni, vedere pag. 395.

Preis CHF / Prezzo in CHF

Modell Modello	Material Materiale	Ventil Piletta	Artikel-Nr. N. di articolo	Beckentiefe Profondità	Exkl. MWST IVA esclusa	Inkl. MWST IVA inclusa	
Rund R 44B	Edelstahl, glanz Acciaio inox, lucido	3 1/2" Raumspar Salvaspazio	10.100.263.00	175 mm	A	971.-	1050.-
		3 1/2" Tipo	10.103.107.00	175 mm	A	930.-	1005.-

# Nemo: NEM N 100

SCHOCK  
CRISTALITE®

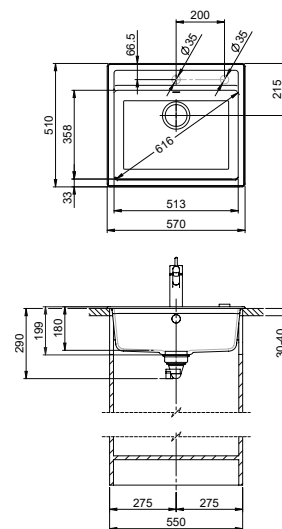
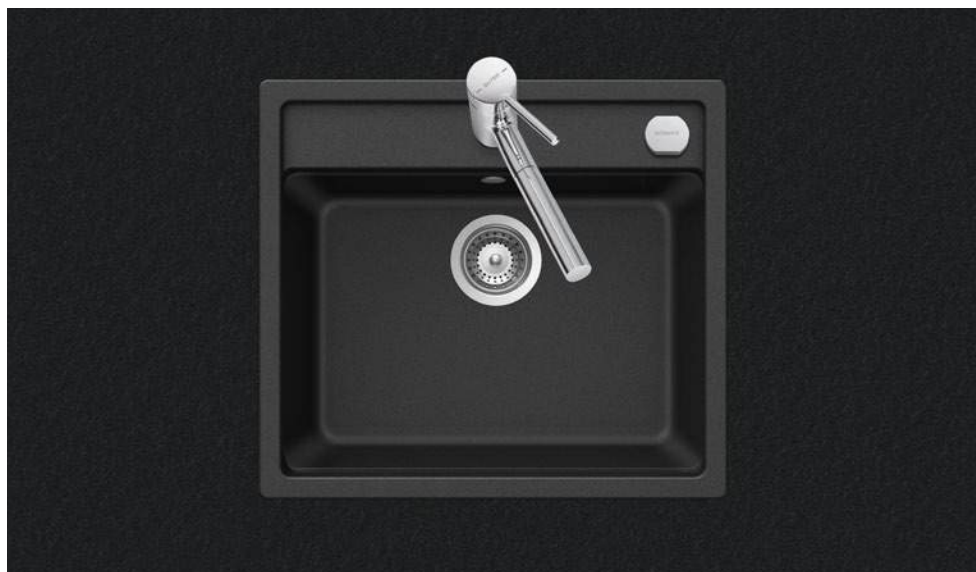

## Optionales Zubehör / Accessori opzionali



**Reinigungsset Easy Care**  
**Kit di pulizia Easy Care**  
 CHF 29.-/N 40.001.509.00

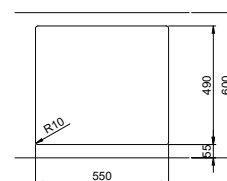

Zeichnung als pdf / dxf und Montageanleitung siehe:  
 V. disegno in formato pdf / dxf e montaggio:  
[suter.ch](http://suter.ch)

## Preis CHF / Prezzo in CHF

Modell Modello	Material Materiale	Ventil Piletta	Artikel-Nr. N. di articolo	Beckentiefe Profondità	Exkl. MWST IVA esclusa	Inkl. MWST IVA inclusa
<b>Nemo NEM N 100*</b>	Cristalite Plus, Nero	3 1/2" Raumspar Salvaspazio	10.102.994.00	180 mm	B 1260.-	1362.-

\*Nur mit Drehknopf lieferbar. / Disponibile solo con pomolo girevole.

## Primus: PRI D 100

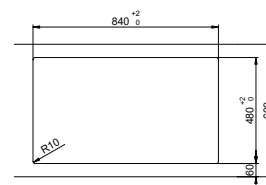
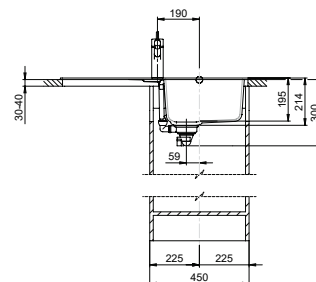
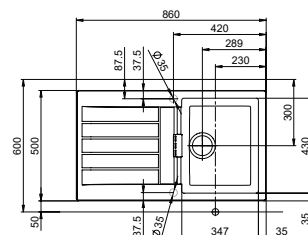
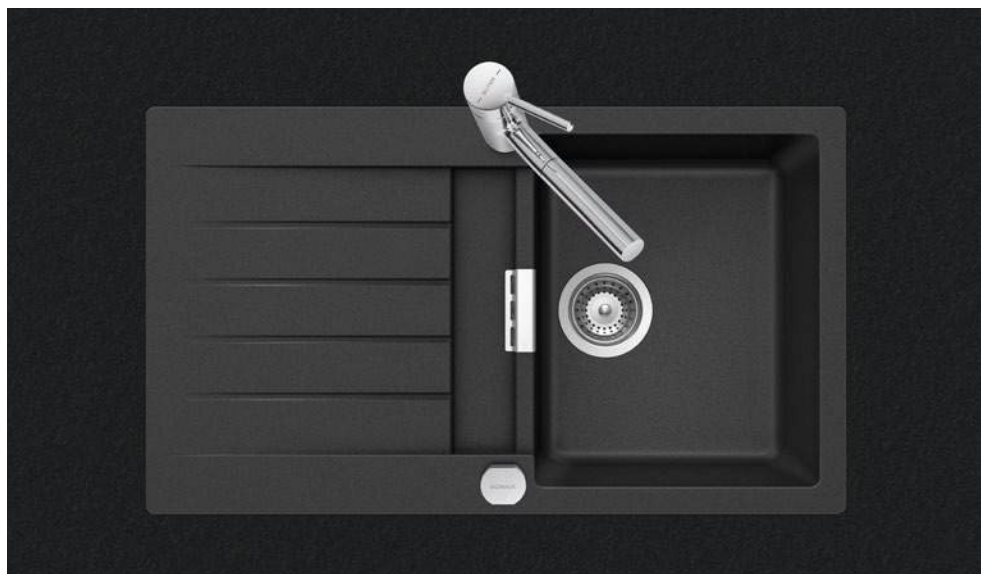
**SCHOCK**  
 CRISTALITE®

## Optionales Zubehör / Accessori opzionali

312

**Reinigungsset Easy Care**  
**Kit di pulizia Easy Care**

CHF 29,-/N 40.001.509.00

 Zeichnung als pdf / dxf und Montageanleitung siehe:  
 V. disegno in formato pdf / dxf e montaggio:  
 suter.ch

## Preis CHF / Prezzo in CHF

Modell Modello	Material Materiale	Ventil Piletta	Artikel-Nr. N. di articolo	Tropfteil Scolatoio	Exkl. MWST IVA esclusa	Inkl. MWST IVA inclusa
<b>Primus PRI D 100*</b>	Cristalite Plus, Nero	3 1/2" Raumspaar Salvaspazio	10.102.996.00	Reversibel Reversibile	B 1243.-	1344.-

\*Nur mit Drehknopf lieferbar. / Disponibile solo con pomolo girevole.

Primus: PRI D 100L

SCHOCK  
CRISTALITE®

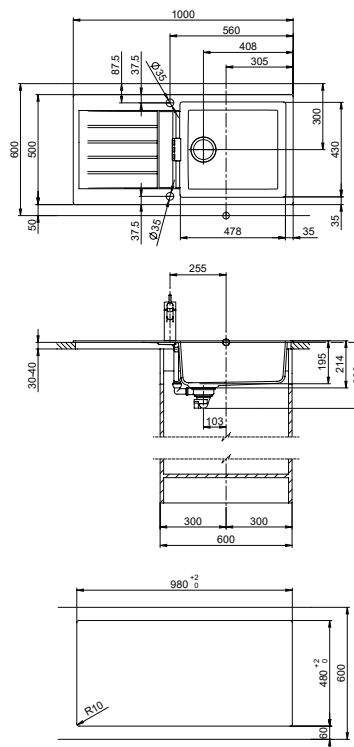
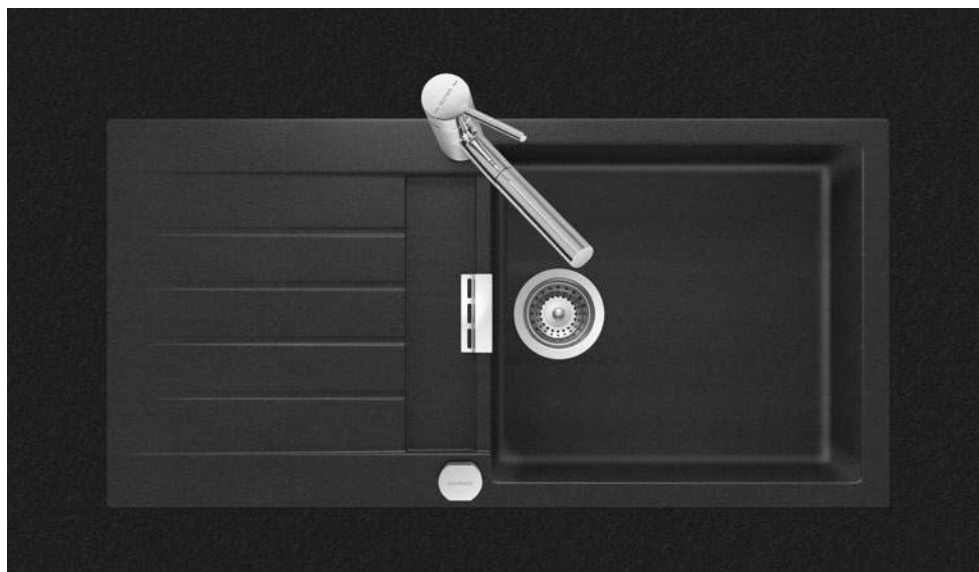

Optionales Zubehör / Accessori opzionali



Reinigungsset Easy Care  
Kit di pulizia Easy Care  
CHF 29.-/N 40.001.509.00

Zeichnung als pdf / dxf und Montageanleitung siehe:  
V. disegno in formato pdf / dxf e montaggio:  
suter.ch

Preis CHF / Prezzo in CHF

Modell Modello	Material Materiale	Ventil Piletta	Artikel-Nr. N. di articolo	Tropfteil Scolatoio	Exkl. MWST IVA esclusa	Inkl. MWST IVA inclusa
Primus PRI D 100L*	Cristalite Plus, Nero	3 1/2" Raumspaar Salvaspazio	10.103.000.00	Reversibel Reversibile	B 1419.-	1534.-

\*Nur mit Drehknopf lieferbar. / Disponibile solo con pomolo girevole.



**Resteschalen / Inox Pad**

Vaschette / Inox Pad **312**

**Schneidebretter**

Taglieri **313**

**Universelles Küchenzubehör**

Accessori per cucina universali **314**

**EVOline Qi Charger****315****EVOline One Einbausteckdose**

Presse da incasso EVOline One **316**

**EVOline BackFlip Einbausteckdose**

Presse da incasso EVOline BackFlip **317**

## Resteschalen / Inox Pad / Vaschette / Inox Pad



## Preis CHF / Prezzo in CHF

Modell Modello	Dimensionen* Dimensioni*	Material Materiale		Artikel-Nr. N. di articolo	Exkl. MWST IVA esclusa	Inkl. MWST IVA inclusa	
1 <b>Comfort:</b> COM-Modelle** Modelli COM**	155 × 335 × 80	Edelstahl, glanz, poliert Acciaio inox, lucido	gelocht forato	18/10 40.000.971.00	C	106.– 115.–	
2 <b>Zaros:</b> ZOS 75 / ZOS 100	155 × 335 × 95	Kunststoff SAN Luran, transparent Sintetico SAN Luran, trasparente nero		40.001.004.00	C	42.– 45.–	
Mehrpreis für Resteschale aus Edelstahl anstelle Kunststoff Sovraprezzo per vaschetta in acciaio inox invece che in sintetico						C	64.– 69.–
3 <b>SIL 9U</b>	87 × 226 × 22	Edelstahl, glanz, poliert Acciaio inox, lucido	gelocht forato	18/10 40.000.042.00	C	81.– 88.–	
4 <b>Linero / Daneo / Brooklyn / Carbon</b>	175 × 395 × 80	Edelstahl, glanz, poliert Acciaio inox, lucido	gelocht forato	18/10 40.000.912.00	C	106.– 115.–	
		Edelstahl, glanz, poliert Acciaio inox, lucido	ungelocht non forato	18/10 40.001.289.00	C	106.– 115.–	
5 <b>Zaros:</b> ZOS 90 <b>Comfort:</b> COM 40 / COM 40U <b>Vantis:</b> alle Modelle / Tutti i modelli*** <b>Silver Star:</b> alle Modelle / Tutti i modelli****	175 × 415 × 80	Edelstahl, glanz, poliert Acciaio inox, lucido	gelocht forato	18/10 40.000.914.00	C	106.– 115.–	
		Edelstahl, glanz, poliert Acciaio inox, lucido	ungelocht non forato	18/10 40.001.290.00	C	106.– 115.–	
6 <b>Vantis:</b> V 50-35IF / V 50-35U <b>Silver Star:</b> SIL 50 / SIL 50U	175 × 345 × 80	Edelstahl, glanz, poliert Acciaio inox, lucido	gelocht forato	18/10 40.000.916.00	C	106.– 115.–	
7 <b>Inox Pad</b>	480 × 448 × 11	Edelstahl, gebürstet Acciaio inox, spazzolato		18/10 40.001.138.00	C	125.– 135.–	
	480 × 418 × 11	Edelstahl, gebürstet Acciaio inox, spazzolato		18/10 40.001.140.00	C	125.– 135.–	

\* Dimensionen in mm. / Dimensioni in mm.

\*\* Ausgenommen COM 40 und COM 40U. / Esclusi COM 40 e COM 40U.

\*\*\* Ausgenommen V 11U, V 50-35IF und V 50-35U / Esclusi V 11U, V 50-35IF e V 50-35U

\*\*\*\* Ausgenommen SIL 50 und SIL 50U / Esclusi SIL 50 e SIL 50U

## Schneidebretter / Taglieri



Preis CHF / Prezzo in CHF							
Modell Modello	Dimensionen* Dimensioni*	Material Materiale	Artikel-Nr. N. di articolo	Exkl. MWST IVA esclusa	Inkl. MWST IVA inclusa		
<b>1</b> Linero / Daneo / Carbon / Brooklyn	220 × 415 × 6	Glas In vetro	40.000.909.00	C	151.–	163.–	
<b>1</b> Zaros: ZOS 75 / ZOS 90 / ZOS 100 Comfort: COM 34 / COM 40 / COM 34U / COM 40U Vantis: alle Modelle / Tutti i modelli** Silver Star: alle Modelle / Tutti i modelli***	220 × 435 × 6	Glas In vetro	40.000.915.00	C	151.–	163.–	
<b>2</b> Comfort: COM 40 / COM 40U Vantis: alle Modelle / Tutti i modelli** Silver Star: alle Modelle / Tutti i modelli***	240 × 452 × 30	Holz-Schneidebrett aus Nussbaum, unbehandelt Taglieri in legno di noce, non trattato	40.001.147.00	C	151.–	163.–	
<b>3</b> Linero / Daneo / Carbon / Brooklyn	220 × 432 × 28	Kunststoff PE 500, weiss Sintetico PE 500, bianco	40.001.277.00	C	151.–	163.–	

\* Dimensionen in mm. / Dimensioni in mm. \*\* Ausgenommen V 11U, V 50-35IF und V 50-35U / Esclusi V 11U, V 50-35IF e V 50-35U

\*\*\* Ausgenommen SIL 50 und SIL 50U / Esclusi SIL 50 e SIL 50U

## Schneidebretter / Taglieri

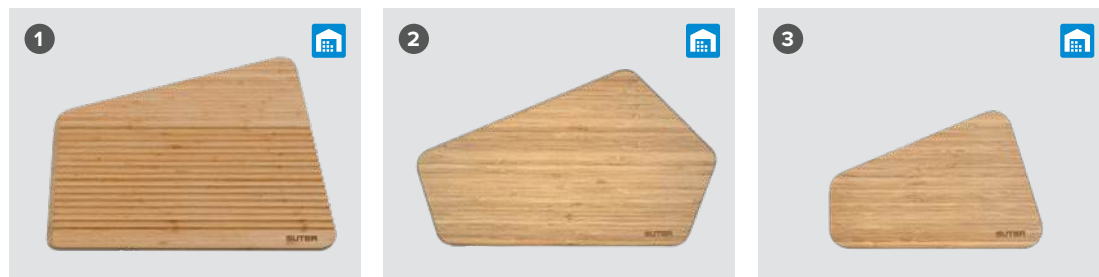

## Universelles Küchenzubehör / Accessori per cucina universali

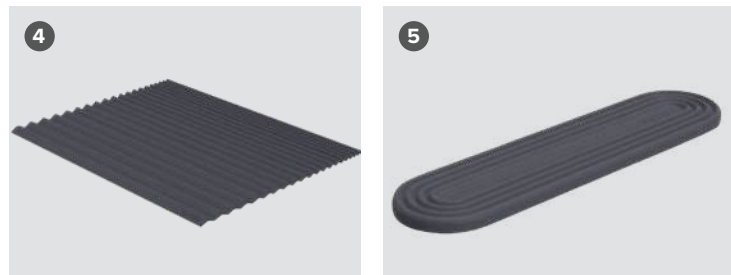

Preis CHF / Prezzo in CHF

Modell Modello	Farbe Colore	Dimensionen* Dimensioni*	Material Materiale	Artikel-Nr. N. di articolo	Exkl. MWST IVA esclusa	Inkl. MWST IVA inclusa
1 Pano		446 × 330 × 20	Bambus Bambù	40.002.005.00	C 38.–	41.–
2 Pasio		398 × 236 × 12	Bambus Bambù	40.001.891.00	C 20.–	22.–
3 Juna		265 × 171 × 10	Bambus Bambù	40.001.892.00	C 16.–	17.–
4 Maro Abtropfmatte Maro tappetino scolapiatti	Dark Grey	450 × 352 × 8	Silikon Silicone	40.002.008.00	C 51.–	55.–
5 Movi Abtropfmatte / Kochlöffelablage Movi tappetino utensili	Dark Grey	304 × 79 × 8	Silikon Silicone	40.002.018.00	C 16.–	17.–

\* Dimensionen in mm. / Dimensioni in mm.

## EVOline Qi Charger



### Technische Daten / Dati tecnici

Mit dem EVOline Qi Charger können mit einer einzigen Ladestation sämtliche Qi-fähige Geräte ohne Kabel oder sonstiges Zubehör geladen werden. Der Einbau erfolgt wahlweise entweder unter der Arbeitsfläche – so dass die Ladestation unsichtbar ist – oder per Aufsatzmontage für Standardausschnitte von 80 mm. Das zu ladende Gerät wird einfach mittig auf die entsprechende Stelle gelegt – Minimalismus pur. Der Ladevorgang erfolgt per Induktion, das heisst, die Ladespule ist nur aktiv, wenn eine Verbindung zu dem zu ladenden Gerät besteht.

Con il caricatore Qi EVOline è possibile caricare i dispositivi compatibili Qi senza cavi o altri accessori. L'installazione viene eseguita sotto il piano di lavoro oppure come attacco per aperture standard di 80 mm, in modo che la stazione di carica resti nascosta. Il dispositivo da ricaricare viene semplicemente appoggiato al centro dell'area predisposta: puro minimalismo. La ricarica avviene per induzione, cioè la bobina di ricarica è attiva solo quando c'è una connessione al dispositivo da caricare.

Betriebsspannung Tensione di esercizio	9 V
Leistungsaufnahme (Betrieb) Potenza assorbita (esercizio)	max. 10 W
Leistungsaufnahme (Standby) Potenza assorbita (standby)	0,2 W
Betriebstemperaturbereich Campo di temperatura d'esercizio	17° C–25° C
Maximaltemperaturbereich Campo di temperatura massima	0° C–40° C
Einbautiefe (inkl. Stecker) Profondità di installazione (spina compresa)	28 mm
Montage / Befestigung Montaggio / fissaggio	unsichtbar unterhalb der Arbeitsplatte oder Aufsatzmontage Invisibile sotto il piano di lavoro o come attacco per aperture

#### Lieferumfang

- Qi-Ladespule nach WPC-Standard Spec. 1.2.2 «Qi»
- USB-Netzteil mit Eurostecker 2-polig (230 V), USB-Verbindungskabel 1 m
- Bedienungs- und Montageanleitung

#### Corredo di fornitura

- Bobina di ricarica Qi secondo le specifiche standard WPC 1.2.2 «Qi»
- Alimentatore USB con spina europea, cavo di collegamento USB 1 m
- Istruzioni d'uso e di montaggio

**i** Bei unsichtbarem Einbau unterhalb der Arbeitsfläche: Die Oberflächen dürfen nicht aus stromleitfähigen Materialien (z. B. alle Metalle, inkl. Edelstahl) bestehen. Empfehlung bei Naturstein: Vor Einbau/Fräsen eine Probe machen, da Spuren von Eisenerz enthalten sein können. Verbleibende Arbeitsplattenstärke bis max. 3 mm im Ausschnittbereich beachten (siehe Zeichnung).

In caso d'installazione sotto il piano di lavoro: le superfici non devono essere fatte di materiali conduttivi (ad es. tutti i metalli, acciaio inox compreso). Raccomandazione per quanto riguarda la pietra naturale: fare una prova prima del montaggio/della fresatura, poiché potrebbero esserci delle tracce di minerale ferifero. Osservare uno spessore rimanente del piano di lavoro fino a un max. di 3 mm nella zona dell'intaglio (vedi disegno).

**i** Es kann erforderlich sein, Smartphone-Hüllen, Back Covers, Wallets oder Etuis zu entfernen, um den Ladevorgang sicherzustellen. Potrebbe essere necessario rimuovere le custodie, le retrocopertine, i portafogli o gli astucci degli smartphone per garantire la ricarica.

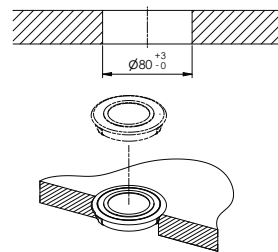
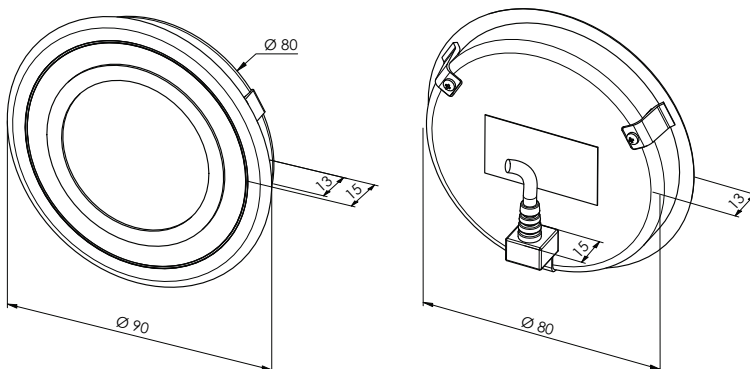

Ausschnitt Einbau Aufsatzmontage:  
Intaglio per montaggio soprapiano:

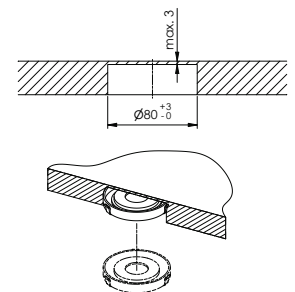

Ausschnitt unsichtbarer Einbau  
(unterhalb der Arbeitsplatte):  
Intaglio per montaggio non visibile  
(sotto il piano di lavoro):

Preis CHF / Prezzo in CHF

Modell Modello	Beschreibung Descrizione	Ausführung Finitura	Artikel-Nr. N. di articolo	Exkl. MWST IVA esclusa	Inkl. MWST IVA inclusa
Qi Charger	Qi-Ladestation zum Einbau in Küchenarbeitsplatten Stazione di ricarica Qi per l'installazione in piani di lavoro di cucine	Kunststoff, schwarz Plastica, nera	40.002.437.00  H	293.–	317.–

## EVOline One Einbausteckdose / Presa da incasso EVOline One



### Technische Daten / Dati tecnici

Die Einbausteckdose EVOline One ist ein kompakter Stromzugang, der sich in jedes Gestaltungskonzept harmonisch integriert. Und das auf eine sehr platzsparende und dezente Weise. Ob in komplett schwarzer Ausführung oder mit Edelstahleinlage: Beide Versionen lassen sich dank den einfach wechselbaren Moduleinsätzen der jeweiligen Anforderung anpassen. Das neue, patentierte Montagesystem hält ab einer Frontstärke von 9 mm. Die Einbautiefe beträgt 50 mm.

La presa da incasso EVOline One è un compatto erogatore di corrente che si integra armoniosamente in qualsiasi configurazione di cucina, e lo fa con un minimo ingombro e con molta discrezione. In versione completa color nero oppure con inserto in acciaio inox, entrambe le versioni sono adattabili alle rispettive esigenze grazie alla semplice intercambiabilità degli inserti modulari. Il nuovo sistema brevettato di montaggio assicura una perfetta tenuta a partire da uno spessore di pannello frontale di 9 mm. La profondità di montaggio è di 50 mm.

Anschlussspannung Tensione di attacco	230 V
Nennstrom maximal Corrente nominale max	16 A
Abmessungen Dimensioni	Ø 59 mm
Abmessungen Dicke Dimensioni Spessore	4 mm
Einbautiefe Profondità di montaggio	50 mm
Blendenbohrung Foratura pannello	Ø 54 mm
Netzanschluss Allacciamento alla rete	Festes Netzanschlusskabel 2,5 m, ohne Netzanschlussstecker (16 A, Typ 23 oder Direktanschluss) Cavo di alimentazione di 2,5 m, senza connettore (16 A, tipo 23 o allacciamento diretto)
Montage/Befestigung Montaggio / fissaggio	von vorne dal davanti

#### Lieferumfang

- Steckdose, inkl. Anschlusskabel 2,5 m
- Ring ohne Deckel
- Ring mit Deckel (360° drehbar)

#### Corredo di fornitura

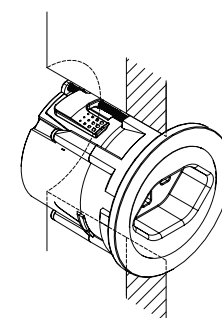
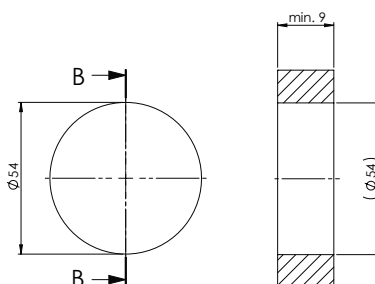
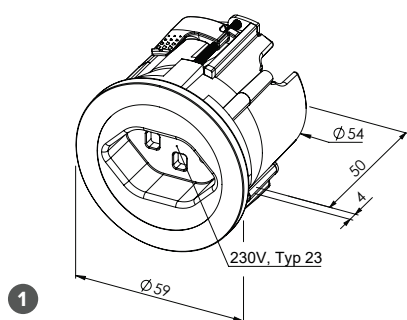

- Presa con cavo di allacciamento di 2,5 m
- Anello senza coperchio
- Anello con coperchio (rotante di 360°)



1

⚡ 230V, 16A Anschluss bauseits  
230V, 16A Collegamento sul cantiere

Preis CHF / Prezzo in CHF

Modell Modello	Beschreibung Descrizione	Ausführung Finitura	Artikel-Nr. N. di articolo	Exkl. MWST IVA esclusa	Inkl. MWST IVA inclusa
EVOline One	Einbausteckdose zum Einbau in Küchenmöbel ab Frontstärke 9 mm. Gesamteinbautiefe: 50 mm. Presa da incasso per montaggio nel mobile della cucina a partire da uno spessore frontale di 9 mm. Profondità totale: 50 mm.	1 Kunststoff schwarz Plastica color nero	40.002.165.00  H	114.–	123.–
		2 Kunststoff schwarz, mit Edelstahleinlage Plastica color nero, con inserto in acciaio inox	40.002.166.00  H	141.–	152.–

# EVOLine BackFlip Einbausteckdose / Presa da incasso EVOLine BackFlip



## Technische Daten / Dati tecnici

Immer verfügbar, aber nie im Weg. Der EVOLine BackFlip ist eine elegante Einbaulösung für die Küche. Geschlossen verbirgt er sich gekonnt in der Arbeitsplatte, kein Wasser kann in die elektrischen Systeme eindringen. Mit einem Finger angetippt, dreht er sich um 180 Grad und präsentiert seine nützlichen Funktionen: Zwei Steckdosen und ein USB-Charger werden sichtbar und liegen so hoch über der Arbeitsfläche, so dass sie vor Wasser geschützt sind. Die geringe Einbautiefe von nur 59 mm ermöglicht eine Montage über Schubladen oder fest installierten Küchengeräten.

Sempre disponibile, ma senza mai essere d'impiccio. L'EVOLine BackFlip è un'elegante soluzione integrata per la cucina. Quando è chiuso esso rimane perfettamente nascosto nel piano di lavoro, in modo che l'acqua non possa penetrare nell'impianto elettrico. Tocendolo con un dito esso ruota di 180 gradi, rendendo visibili le sue utili funzioni: due prese di corrente e un'unità di ricarica USB che si elevano al di sopra del piano di lavoro in modo da essere protetti dall'acqua. La profondità di incasso di soli 59 mm ne consente il montaggio al di sopra di cassetti o di apparecchi per cucina fissi.

Gerätemasse (Breite, Tiefe, Höhe) Dimensioni (larghezza, profondità, altezza)	225.2 × 104.8 × 59 mm
Einbauoptionen / Opzioni d'installazione	Flächenbündig oder aufgesetzt A filo top o sopra piano
Eingangsspannung / Tensione di ingresso	230 V
Ausgangsspannung / Tensione di uscita	230 V
Spannungsart / Tipo di tensione	AC
Bestückung / Dotazione	2 × Steckdose, 0°, 16 A, Typ 23 1 × USB-Charger Typ C* (mit Ladefunktion, ohne PC-Anbindung. Für handelsübliche Geräte wie Mobiltelefone, Tablets und andere mobile Geräte) 2 × prese di corrente, 0°, 16 A, tipo 23 1 × porta USB tipo C* (con funzione di ricarica senza collegamento con PC. Per dispositivi di uso corrente come cellulari, tablet e altri dispositivi mobili)
Netzanschluss / Allacciamento alla rete	Festes Netzanschlusskabel 2,0 m, ohne Netzanschlusstecker (16 A, Typ 23 oder Direktanschluss) Cavo di alimentazione di 2,0 m, senza connettore (16 A, tipo 23 o allacciamento diretto)



**i** Alle Modelle sind auf USB-Charger Typ C umgestellt.  
Tutti i modelli sono convertiti per il caricatore USB del tipo C.

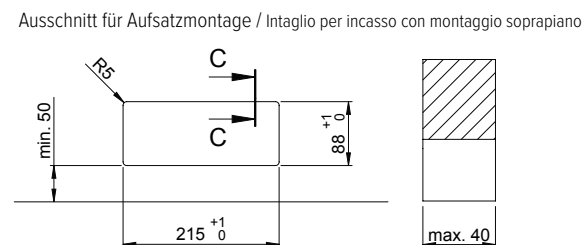
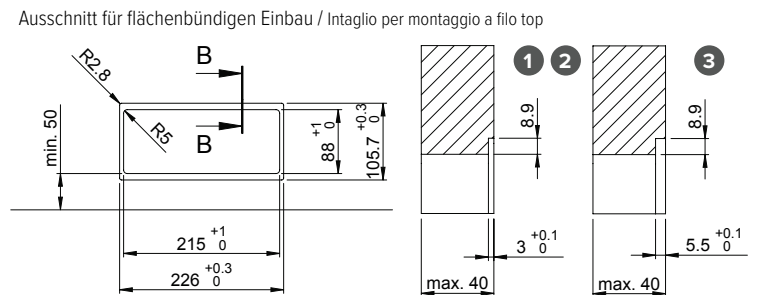
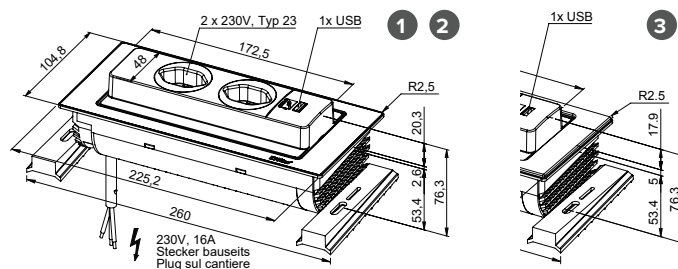

**i** Netzanschlusstecker (16 A, Typ 23 oder Direktanschluss) ist nicht im Lieferumfang enthalten.  
Connettore di rete (16 A, tipo 23 o per connessione diretta) non incluso nel corredo di fornitura.

## Preis CHF / Prezzo in CHF

Modell Modello	Beschreibung Descrizione	Ausführung Finitura	Artikel-Nr. N. di articolo	Exkl. MWST IVA esclusa	Inkl. MWST IVA inclusa
EVOLine BackFlip	Einbausteckdose zum Einbau in Arbeitsplatten bis 40 mm Stärke Gesamteinbautiefe: 59 mm, Dreheinsatz Kunststoff schwarz Presa da incasso per piani di lavoro con spessore fino a 40 mm Profondità totale di incasso: 59 mm, inserto girevole in plastica nera	1 Edelstahl, massiv Acciaio inox, massiccio	40.002.500.00 <b>L</b> H	271.–	293.–
		2 Edelstahl, schwarz matt Acciaio inox, nero opaco	40.002.495.00 <b>L</b> H	336.–	363.–
		3 Glas schwarz Vetro nero	40.002.501.00 <b>L</b> H	422.–	456.–

\* Die Ladefunktion des USB-Chargers kann auf Grund der Vielzahl der Anbieter und Geräte nicht in jedem Fall garantiert werden.  
Data la grande varietà di produttori e di dispositivi, non è possibile garantire la funzionalità dell'unità di ricarica USB in ogni singolo caso.



**Suter**

Merano	320
Areo	320
Nuno	321
Zetrix	322
Meno	323
Evio	324-325
Lumo	325
Eco Plus	325
Devo	326
Vamos	326
Ambiano	327-328
Up & Down	328
Arkano	328-329
Raio	330

**KWC**

**Exklusiv bei Suter / Un'esclusiva di Suter**

Luna-E	331
--------	-----

**KWC**

Inox	332
Zoe	332
Livello	332
Ono	333
Bistro E	333
Bevo	333-334
Enia E	335
Domo	335-336
Suno	336-337
Ava	337
Wamas	338
Isla	338
Fit	338-339

**Gessi**

**Exklusiv bei Suter / Un'esclusiva di Suter**

Segno	340-341
Stelo	341-342
Officine V	343
Soletto	343
Divino	344

**Laufen**

**Exklusiv bei Suter / Un'esclusiva di Suter**

Vara Epoc	345
Lico	347
Kiano	347-348
Eleo	349
Twin	350
Sento	350
Epoc	350-351
Pino	351

**Laufen**

Twin	352
Twin S	352
Twinplus	353
Triathlon	354
Swap	354

**Hansgrohe**

Talis M54	355-356
Zesis M33-150	357
Zesis M33-150 CoolStart	357
Logis	357

**Dornbracht**

**Exklusiv bei Suter / Un'esclusiva di Suter**

Tara Ultra	358
Sync	358
Koya	358-359

**Dornbracht**

Tara Ultra	360
------------	-----

**i** 5 Jahre Herstellergarantie auf das komplette Küchenarmaturensortiment für alle Marken. Ausgenommen sind Multifunktionsarmaturen Laufen Vara Epoc.  
 Garanzia del produttore di 5 anni sulla gamma completa di rubinetteria da cucina per tutte le marche. Sono escluse le rubinetterie multifunzione Laufen Vara Epoc.

**Energieetikette / Etichetta energetica**

Die Energieetikette für Sanitärprodukte zeigt auf einen Blick, ob Armaturen wenig Energie verbrauchen (Klasse A) oder viel (Klasse G). In diesem Katalog werden die Armaturen mit dem entsprechenden Pfeil und der Kategorie markiert. Die Werte der Energieetikette für die Küchenmischer beziehen sich immer auf die Ausführungen mit Zubehör im Auslieferungszustand.

L'etichetta energetica applicata sugli articoli sanitari fornisce un'indicazione immediata del minore (classe A) o maggiore (classe G) consumo energetico di una rubinetteria. In questo catalogo tutte le rubinetterie sono contrassegnate con la rispettiva freccia e categoria. I valori di efficienza energetica relativi ai miscelatori per cucina si riferiscono sempre a versioni con accessori nello stato di fornitura.

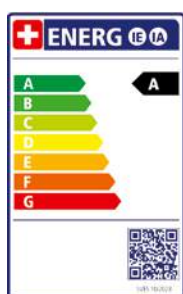

- A** Energieeffizienzklasse A / Classe di efficienza energetica A
- B** Energieeffizienzklasse B / Classe di efficienza energetica B
- C** Energieeffizienzklasse C / Classe di efficienza energetica C
- D** Energieeffizienzklasse D / Classe di efficienza energetica D

- E** Energieeffizienzklasse E / Classe di efficienza energetica E
- F** Energieeffizienzklasse F / Classe di efficienza energetica F
- G** Energieeffizienzklasse G / Classe di efficienza energetica G

## SUTER

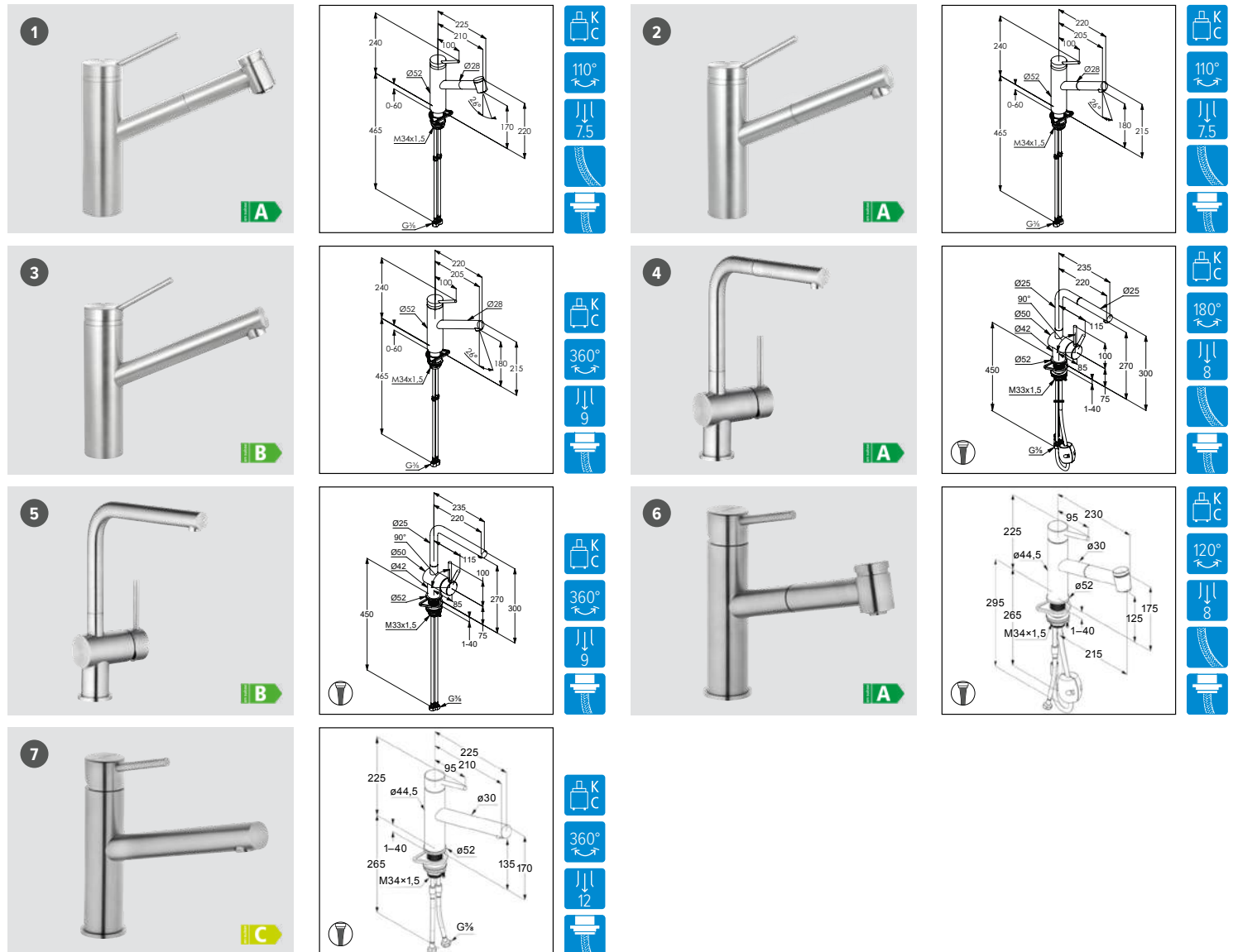

**i** Passende Dispenser und Zugknöpfe in allen Oberflächen auf den Seiten 363–369.  
Dispenser e pomoli abbinabili a tutte le superfici alle pagine 363–369.

Preis CHF/Prezzo in CHF

Name Nome	Modell Modello	Version / Oberfläche Versione / Superficie	Artikel-Nr. N. di articolo	Exkl. MWST IVA esclusa	Inkl. MWST IVA inclusa
<b>1 Merano</b>	Auszugsbrause Doccia estraibile	☆ Edelstahl, massiv Acciaio inox, massiccio	40.001.447.00 <b>L</b> H	923.–	998.–
<b>2 Merano</b>	Zugauslauf Boccaglio estraibile	☆ Edelstahl, massiv Acciaio inox, massiccio	40.001.446.00 <b>L</b> H	885.–	957.–
<b>3 Merano</b>	Schwenkauslauf Braccio girevole	Edelstahl, massiv Acciaio inox, massiccio	40.001.445.00 <b>L</b> H	798.–	863.–
<b>4 Areo</b>	Zugauslauf Boccaglio estraibile	Ⓢ Side lever L/Edelstahl, massiv Side lever L/Acciaio inox, massiccio	40.002.212.00 <b>L</b> H	629.–	680.–
<b>5 Areo</b>	Schwenkauslauf Braccio girevole	Ⓢ Side lever L/Edelstahl, massiv Side lever L/Acciaio inox, massiccio	40.002.213.00 <b>L</b> H	484.–	523.–
<b>6 Areo</b>	Auszugsbrause Doccia estraibile	Ⓢ Top lever/Edelstahl, massiv Top lever/Acciaio inox, massiccio	40.002.133.00 <b>L</b> H	607.–	656.–
<b>7 Areo</b>	Schwenkauslauf Braccio girevole	Ⓢ Top lever/Edelstahl, massiv Top lever/Acciaio inox, massiccio	40.002.132.00 <b>L</b> H	479.–	518.–

☆ Mit Nylonschlauch / Con flessibile in nylon Ⓢ Mit Laminarstrahl / Con getto laminare

SUTER

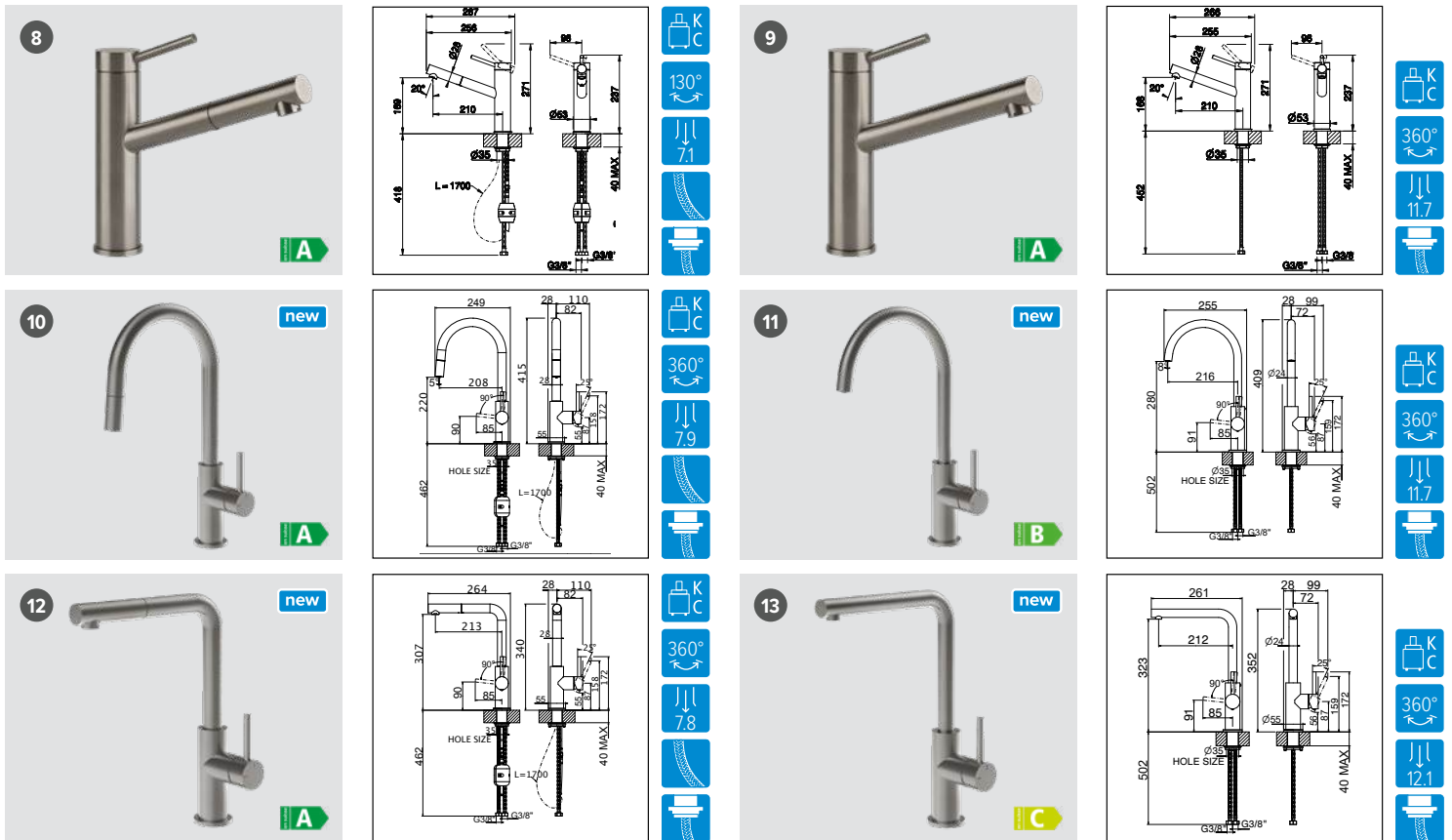

Preis CHF/Prezzo in CHF

	Name Nome	Modell Modello	Version / Oberfläche Versione / Superficie	Artikel-Nr. N. di articolo	Exkl. MWST IVA esclusa	Inkl. MWST IVA inclusa
8	Nuno*	Zugauslauf Boccaglio estraibile	Edelstahl, massiv Acciaio inox, massiccio	40.002.945.00 L H	365.-	395.-
9	Nuno*	Schwenkauslauf Braccio girevole	Edelstahl, massiv Acciaio inox, massiccio	40.002.944.00 L H	315.-	341.-
10	Nuno	Zugauslauf Boccaglio estraibile	Side lever C / Edelstahl, massiv Side lever C / Acciaio inox, massiccio	40.003.050.00 L H	415.-	449.-
11	Nuno	Schwenkauslauf Braccio girevole	Side lever C / Edelstahl, massiv Side lever C / Acciaio inox, massiccio	40.003.049.00 L H	340.-	368.-
12	Nuno	Zugauslauf Boccaglio estraibile	Side lever L / Edelstahl, massiv Side lever L / Acciaio inox, massiccio	40.003.048.00 L H	415.-	449.-
13	Nuno	Schwenkauslauf Braccio girevole	Side lever L / Edelstahl, massiv Side lever L / Acciaio inox, massiccio	40.003.047.00 L H	340.-	368.-

\* Kaltbebelstellung Mitte / Leva del freddo in posizione centrale ☆ Mit Nylonschlauch / Con flessibile in nylon

## SUTER

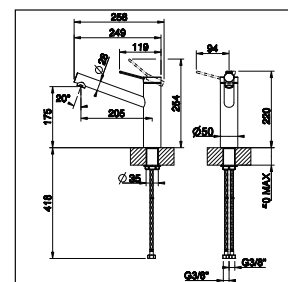
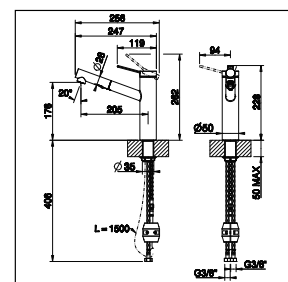

**i** Passende Dispenser und Zugknöpfe  
in allen Oberflächen auf den  
Seiten 363–369.  
Dispenser e pomoli abbinabili a tutte le superfici  
alle pagine 363–369.

Preis CHF/Prezzo in CHF

Name Nome	Modell Modello	Version / Oberfläche Versione / Superficie	Artikel-Nr. N. di articolo	Exkl. MWST IVA esclusa	Inkl. MWST IVA inclusa
14	Zetrix*	Chrom Cromato	40.002.941.00 <b>L</b> H	238.–	257.–
15		Edelstahl-Finish Acciaio inox-finish	40.002.942.00 <b>L</b> H	298.–	322.–
16		Pulverbeschichtung schwarz, matt Rivestimento con polvere nero, opaco	40.002.943.00 <b>L</b> H	298.–	322.–
17	Zetrix*	Chrom Cromato	40.002.938.00 <b>L</b> H	178.–	192.–
18		Edelstahl-Finish Acciaio inox-finish	40.002.939.00 <b>L</b> H	227.–	245.–
19		Pulverbeschichtung schwarz, matt Rivestimento con polvere nero, opaco	40.002.940.00 <b>L</b> H	227.–	245.–

\* Kaltbebelstellung Mitte / Leva del freddo in posizione centrale ☆ Mit Nylonschlauch / Con flessibile in nylon

**SUTER**

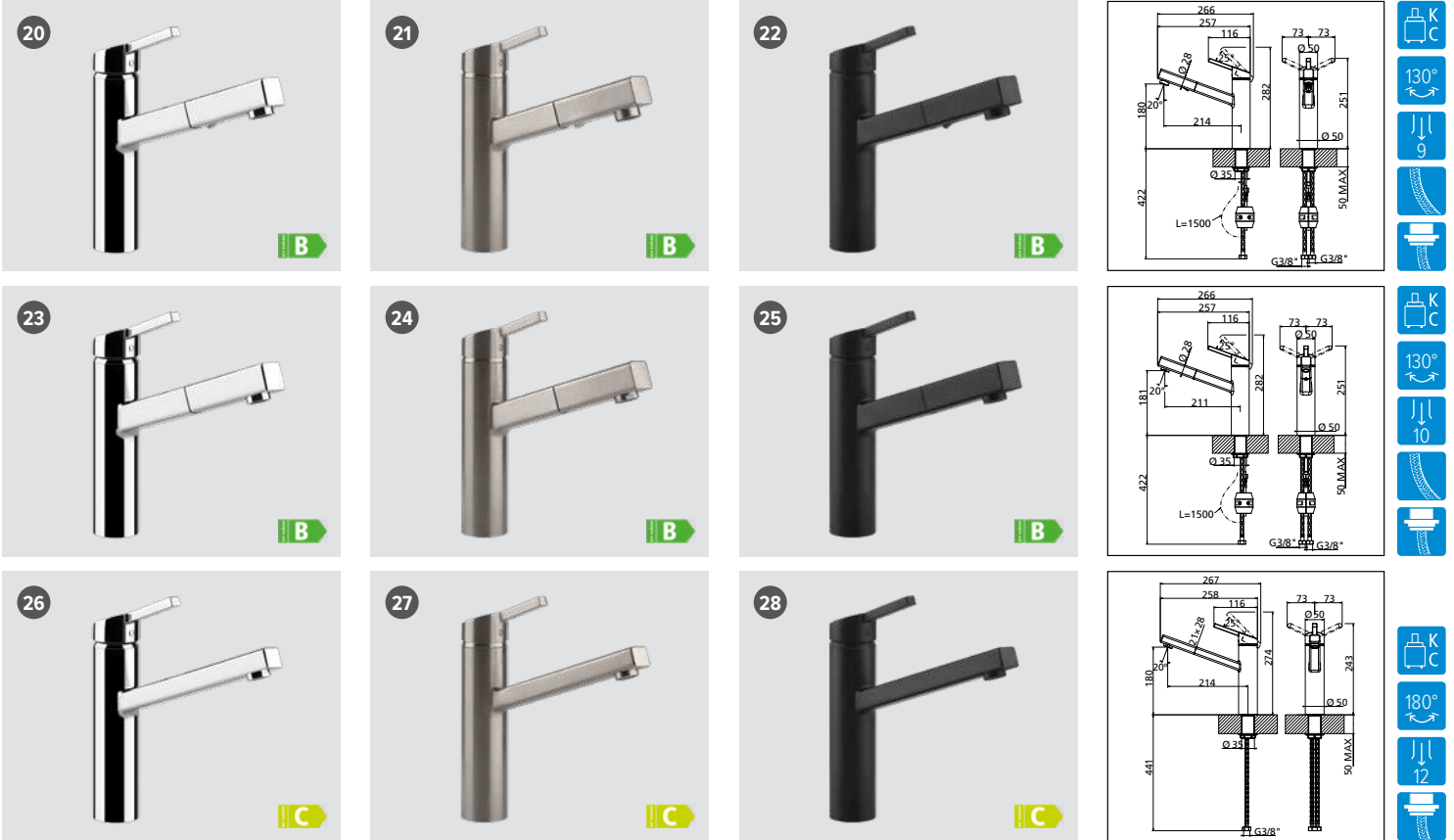

Preis CHF/Prezzo in CHF

Name Nome	Modell Modello	Version/Oberfläche Versione/Superficie	Artikel-Nr. N. di articolo	Exkl. MWST IVA esclusa	Inkl. MWST IVA inclusa
20	Meno Auszugsbrause Doccia estraibile	Chrom Cromato	40.002.387.00 L H	498.–	538.–
21		Edelstahl-Finish Acciaio inox-finish	40.002.388.00 L H	627.–	678.–
22		Pulverbeschichtung schwarz, matt Rivestimento con polvere nero, opaco	40.002.389.00 L H	627.–	678.–
23	Meno Zugauslauf Boccaglio estraibile	Chrom Cromato	40.002.384.00 L H	437.–	472.–
24		Edelstahl-Finish Acciaio inox-finish	40.002.385.00 L H	564.–	610.–
25		Pulverbeschichtung schwarz, matt Rivestimento con polvere nero, opaco	40.002.386.00 L H	564.–	610.–
26	Meno Schwenkauslauf Braccio girevole	Chrom Cromato	40.002.381.00 L H	350.–	378.–
27		Edelstahl-Finish Acciaio inox-finish	40.002.382.00 L H	472.–	510.–
28		Pulverbeschichtung schwarz, matt Rivestimento con polvere nero, opaco	40.002.383.00 L H	472.–	510.–

☆ Mit Nylonschlauch / Con flessibile in nylon

## SUTER

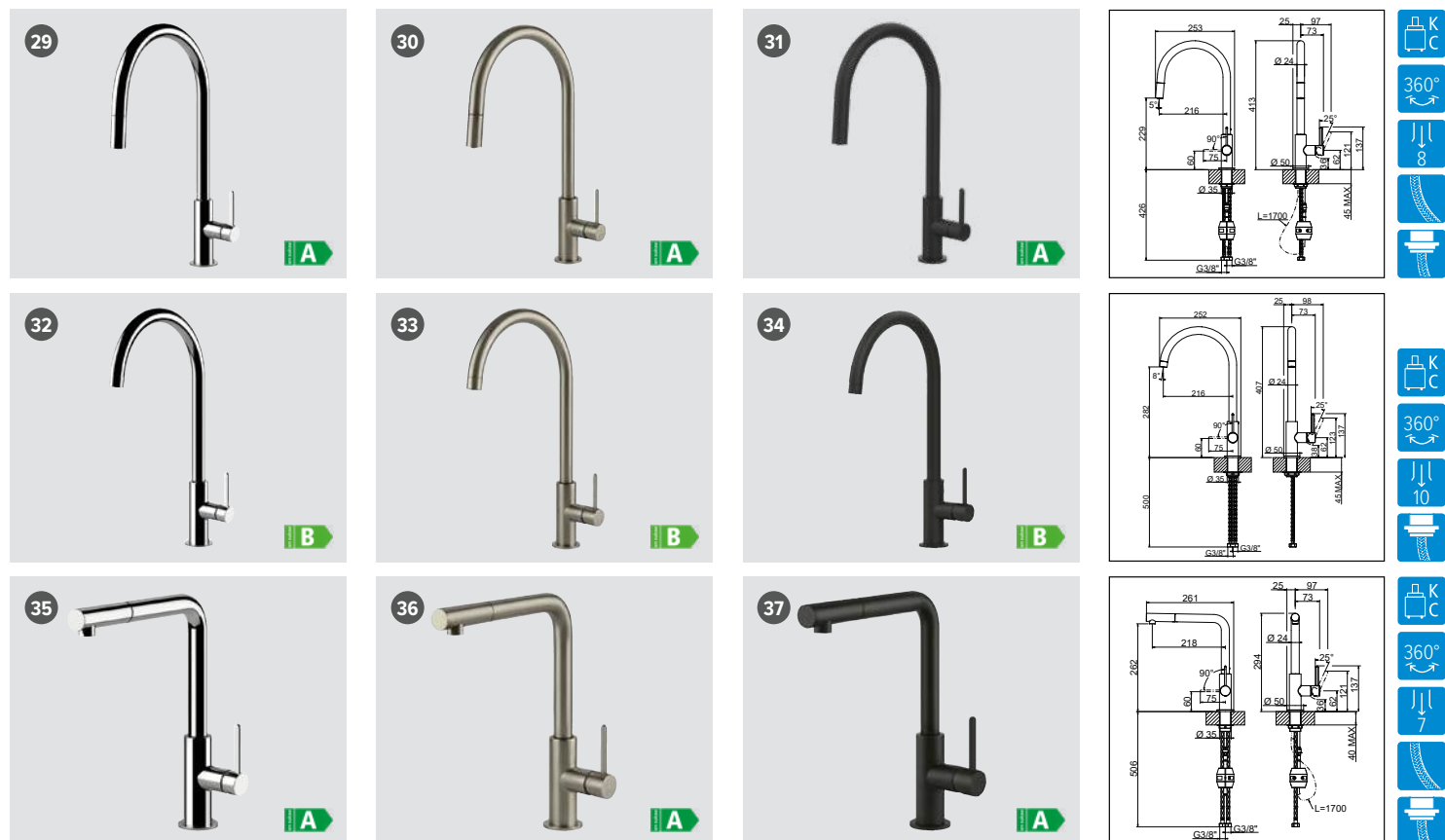

**i** Passende Dispenser und Zugknöpfe in allen Oberflächen auf den Seiten 363–369.  
Dispenser e pomoli abbinabili a tutte le superfici alle pagine 363–369.

Preis CHF/Prezzo in CHF

Name Nome	Modell Modello	Version/Oberfläche Versione/Superficie	Artikel-Nr. N. di articolo	Exkl. MWST IVA esclusa	Inkl. MWST IVA inclusa
29	Evio Zugauslauf Boccaglio estraibile	Side lever C / Chrom Side lever C / Cromato	40.002.718.00 L H	404.–	437.–
30		Side lever C / Edelstahl-Finish Side lever C / Acciaio inox-finish	40.002.719.00 L H	476.–	515.–
31		Side lever C / Pulverbeschichtung schwarz, matt Side lever C / Rivestimento con polvere nero, opaco	40.002.720.00 L H	476.–	515.–
32	Evio Schwenkauslauf Braccio girevole	Side lever C / Chrom Side lever C / Cromato	40.002.715.00 L H	351.–	379.–
33		Side lever C / Edelstahl-Finish Side lever C / Acciaio inox-finish	40.002.716.00 L H	403.–	436.–
34		Side lever C / Pulverbeschichtung schwarz, matt Side lever C / Rivestimento con polvere nero, opaco	40.002.717.00 L H	403.–	436.–
35	Evio Zugauslauf Boccaglio estraibile	Side lever L / Chrom Side lever L / Cromato	40.002.710.00 L H	404.–	437.–
36		Side lever L / Edelstahl-Finish Side lever L / Acciaio inox-finish	40.002.711.00 L H	476.–	515.–
37		Side lever L / Pulverbeschichtung schwarz, matt Side lever L / Rivestimento con polvere nero, opaco	40.002.713.00 L H	476.–	515.–

☆ Mit Nylonschlauch / Con flessibile in nylon

**SUTER**



**Preis CHF/Prezzo in CHF**

Name Nome	Modell Modello	Version/Oberfläche Versione/Superficie	Artikel-Nr. N. di articolo	Exkl. MWST IVA esclusa	Inkl. MWST IVA inclusa
38		Side lever L/Chrom Side lever L/Cromato	40.002.707.00 L H	351.–	379.–
39	Evio Schwenkauslauf Braccio girevole	Side lever L/Edelstahl-Finish Side lever L/Acciaio inox-finish	40.002.708.00 L H	403.–	436.–
40		Side lever L/Pulverbeschichtung schwarz, matt Side lever L/Rivestimento con polvere nero, opaco	40.002.709.00 L H	403.–	436.–
41	Evio Zugauslauf Boccaglio estraibile	☆ Side lever L/Edelstahl, massiv Side lever L/Acciaio inox, massiccio	40.002.714.00 L H	573.–	619.–
42	Evio Schwenkauslauf Braccio girevole	Side lever L/Edelstahl, massiv Side lever L/Acciaio inox, massiccio	40.002.712.00 L H	456.–	493.–
43	Lumo Auszugsbrause Doccia estraibile	☆ Chrom Cromato	40.001.651.00 L H	502.–	543.–
44	Lumo Schwenkauslauf Braccio girevole	Chrom Cromato	40.001.652.00 L H	350.–	378.–
45	Eco Plus Auszugsbrause Doccia estraibile	☆ Chrom Cromato	40.001.534.00 L H	498.–	538.–
46	Eco Plus* Schwenkauslauf Braccio girevole	Chrom Cromato	40.001.535.00 L H	302.–	326.–

☆ Mit Nylonschlauch / Con flessibile in nylon

\* Modell ist mit Befestigungs-Set mit Befestigungsbügel (Hufeisen) ausgerüstet. Bei der Montage die mitgelieferte Verstärkungsplatte (Dreieck) verwenden.  
\* Il modello è dotato di set di fissaggio con staffa di fissaggio (a forma di ferro di cavallo). Utilizzare la piastra di rinforzo in dotazione (triangolo) per il montaggio.

## SUTER

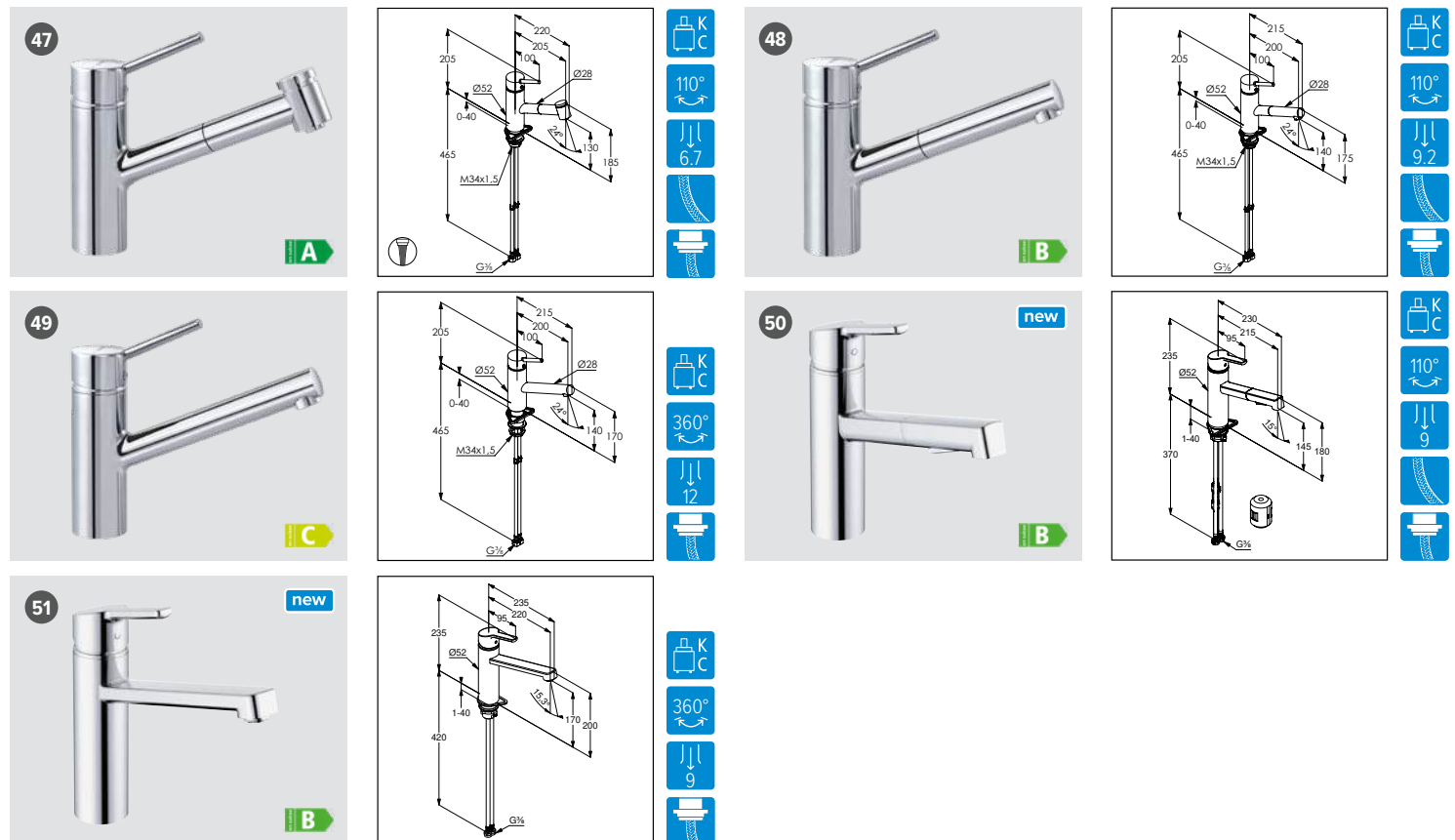

**i** Passende Dispenser und Zugknöpfe in allen Oberflächen auf den Seiten 363–369.  
Dispenser e pomoli abbinabili a tutte le superfici alle pagine 363–369.

Preis CHF/Prezzo in CHF

Name Nome	Modell Modello	Version/Oberfläche Versione/Superficie	Artikel-Nr. N. di articolo	Exkl. MWST IVA esclusa	Inkl. MWST IVA inclusa
47 Devo	Auszugsbrause Doccia estraibile	Chrom Cromato	40.001.648.00	455.–	492.–
48 Devo	Zugauslauf Boccaglio estraibile	Chrom Cromato	40.001.649.00	386.–	417.–
49 Devo	Schwenkauslauf Braccio girevole	Chrom Cromato	40.001.650.00	302.–	326.–
50 Vamos	Auszugsbrause Doccia estraibile	Chrom Cromato	40.003.091.00	248.–	268.–
51 Vamos	Schwenkauslauf Braccio girevole	Chrom Cromato	40.003.090.00	188.–	203.–

☆ Mit Nylonschlauch / Con flessibile in nylon    Ⓢ Mit Laminarstrahl / Con getto laminare

**SUTER**

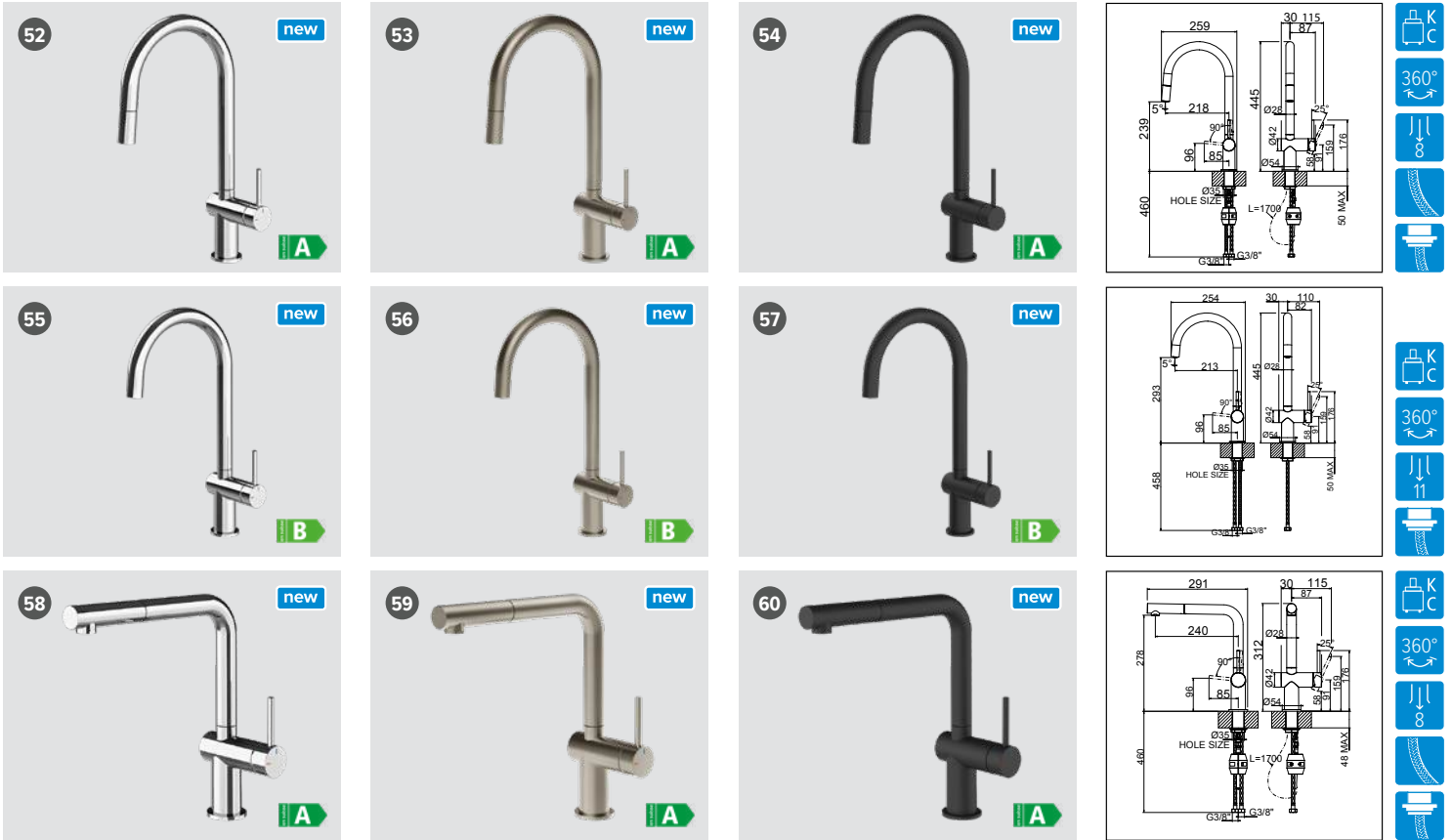

**Preis CHF/Prezzo in CHF**

Name Nome	Modell Modello	Version/Oberfläche Versione/Superficie	Artikel-Nr. N. di articolo	Exkl. MWST IVA esclusa	Inkl. MWST IVA inclusa
52	<b>Ambiano</b> Zugauslauf Boccaglio estraibile	Side lever C/Chrom Side lever C/Cromato	40.003.060.00 L H	345.–	373.–
53		Side lever C/Edelstahl-Finish Side lever C/Acciaio inox-finish	40.003.061.00 L H	435.–	470.–
54		Side lever C/Pulverbeschichtung schwarz, matt Side lever C/Rivestimento con polvere nero, opaco	40.003.062.00 L H	435.–	470.–
55	<b>Ambiano</b> Schwenkauslauf Braccio girevole	Side lever C/Chrom Side lever C/Cromato	40.003.057.00 L H	285.–	308.–
56		Side lever C/Edelstahl-Finish Side lever C/Acciaio inox-finish	40.003.058.00 L H	365.–	395.–
57		Side lever C/Pulverbeschichtung schwarz, matt Side lever C/Rivestimento con polvere nero, opaco	40.003.059.00 L H	365.–	395.–
58	<b>Ambiano</b> Zugauslauf Boccaglio estraibile	Side lever L/Chrom Side lever L/Cromato	40.003.054.00 L H	325.–	351.–
59		Side lever L/Edelstahl-Finish Side lever L/Acciaio inox-finish	40.003.055.00 L H	415.–	449.–
60		Side lever L/Pulverbeschichtung schwarz, matt Side lever L/Rivestimento con polvere nero, opaco	40.003.056.00 L H	415.–	449.–

☆ Mit Nyllonschlauch / Con flessibile in nylon

## SUTER

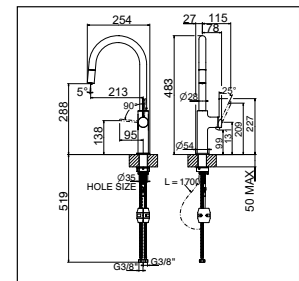
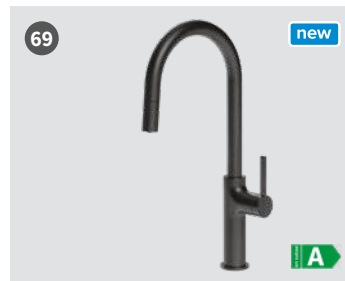
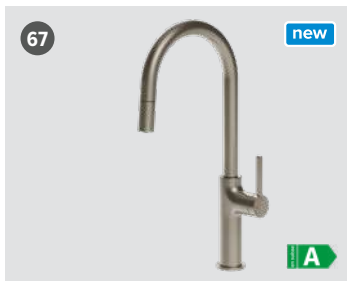
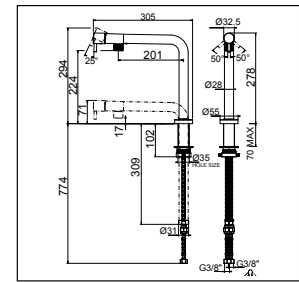
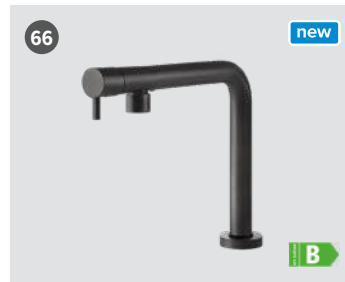
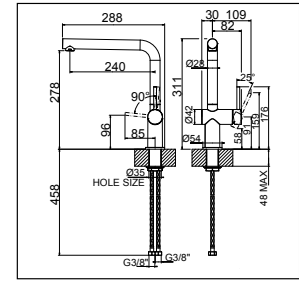

**i** Passende Dispenser und Zugknöpfe in allen Oberflächen auf den Seiten 363–369.  
Dispenser e pomoli abbinabili a tutte le superfici alle pagine 363–369.

Preis CHF/Prezzo in CHF

Name Nome	Modell Modello	Version/Oberfläche Versione/Superficie	Artikel-Nr. N. di articolo	Exkl. MWST IVA esclusa	Inkl. MWST IVA inclusa
61	Ambiano	Side lever L/Chrom Side lever L/Cromato	40.003.051.00 L H	275.–	297.–
62		Side lever L/Edelstahl-Finish Side lever L/Acciaio inox-finish	40.003.052.00 L H	355.–	384.–
63		Side lever L/Pulverbeschichtung schwarz, matt Side lever L/Rivestimento con polvere nero, opaco	40.003.053.00 L H	355.–	384.–
64	Up & Down Unterfenster- armatur Rubinetto sottofinestra	Chrom Cromato	40.003.066.00 L H	685.–	740.–
65		Edelstahl-Finish Acciaio inox-finish	40.003.067.00 L H	775.–	838.–
66		PVD-Beschichtung, Graphit Rivestimento a PVD, grafite	40.003.068.00 L H	855.–	924.–
67	Arkano	Side lever C/Edelstahl-Finish Side lever C/Acciaio inox-finish	40.003.069.00 L H	545.–	589.–
68		Side lever C/Pulverbeschichtung schwarz, matt Side lever C/Rivestimento con polvere nero, opaco	40.003.070.00 L H	545.–	589.–
69		Side lever C/PVD-Beschichtung, Graphit Side lever C/Rivestimento a PVD, grafite	40.003.071.00 L H	625.–	676.–

☆ Mit Nylonschlauch / Con flessibile in nylon \* Verbleibende Höhe in abgesenktem Zustand / Altezza restante nella posizione abbassata

SUTER

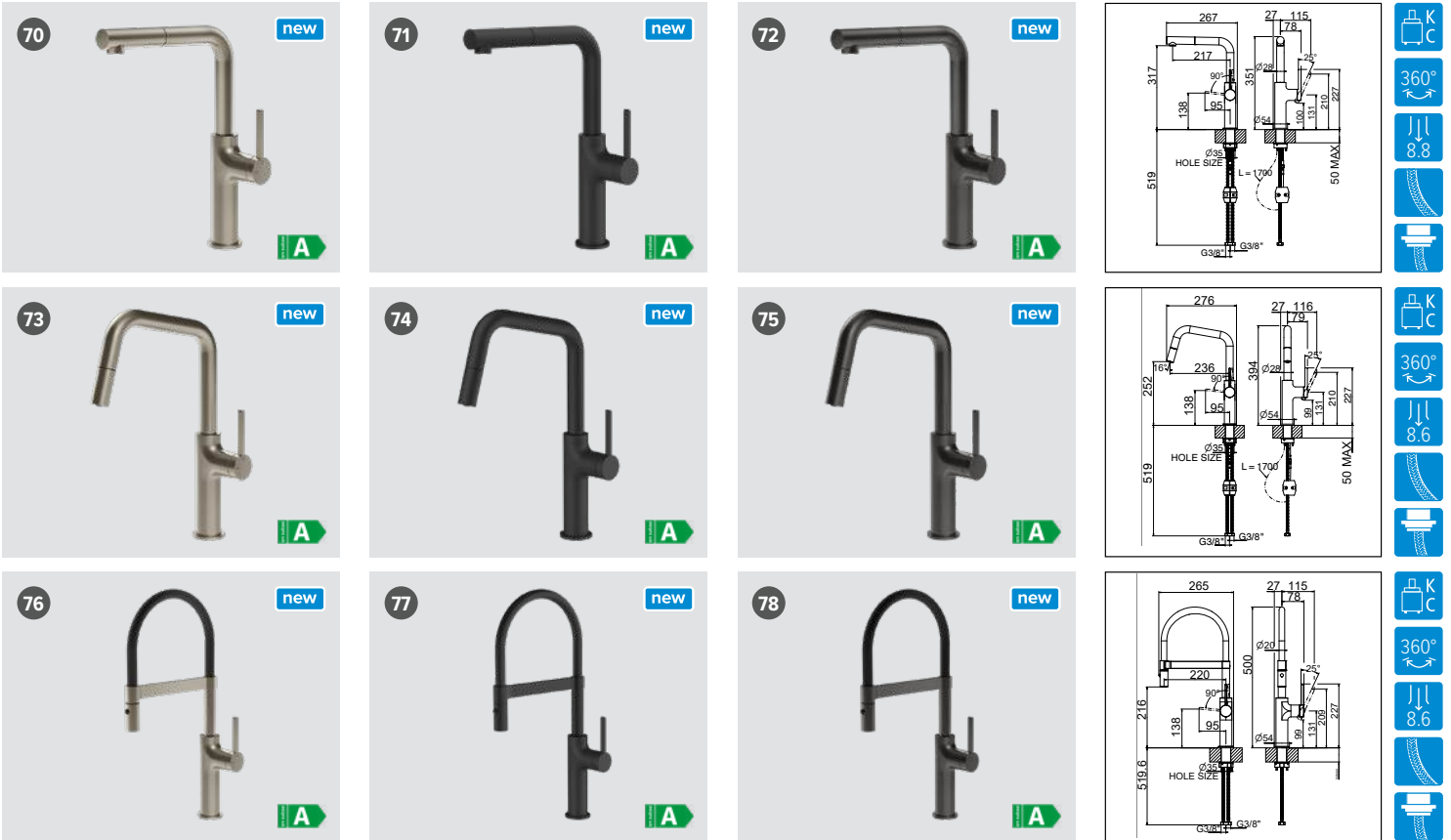

Preis CHF/Prezzo in CHF

Name Nome	Modell Modello	Version/Oberfläche Versione/Superficie	Artikel-Nr. N. di articolo	Exkl. MWST IVA esclusa	Inkl. MWST IVA inclusa
70	Arkano Zugauslauf Boccaglio estraibile	Side lever L/Edelstahl-Finish Side lever L/Acciaio inox-finish	40.003.075.00 L H	515.-	557.-
71		Side lever L/Pulverbeschichtung schwarz, matt Side lever L/Rivestimento con polvere nero, opaco	40.003.076.00 L H	515.-	557.-
72		Side lever L/PVD-Beschichtung, Graphit Side lever L/Rivestimento a PVD, grafite	40.003.077.00 L H	595.-	643.-
73	Arkano Zugauslauf Boccaglio estraibile	Side lever U/Edelstahl-Finish Side lever U/Acciaio inox-finish	40.003.072.00 L H	545.-	589.-
74		Side lever U/Pulverbeschichtung schwarz, matt Side lever U/Rivestimento con polvere nero, opaco	40.003.073.00 L H	545.-	589.-
75		Side lever U/PVD-Beschichtung, Graphit Side lever U/Rivestimento a PVD, grafite	40.003.074.00 L H	625.-	676.-
76	Arkano Profibrause Doccia professionale	Edelstahl-Finish Acciaio inox-finish	40.003.078.00 L H	735.-	795.-
77		Pulverbeschichtung schwarz, matt Rivestimento con polvere nero, opaco	40.003.079.00 L H	735.-	795.-
78		PVD-Beschichtung, Graphit Rivestimento a PVD, grafite	40.003.080.00 L H	815.-	881.-

☆ Mit Nylonschlauch / Con flessibile in nylon

## SUTER

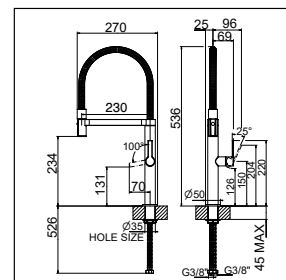
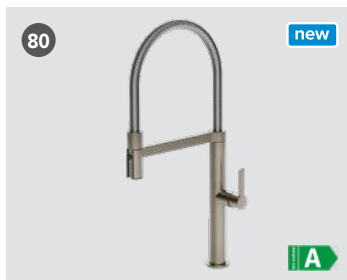
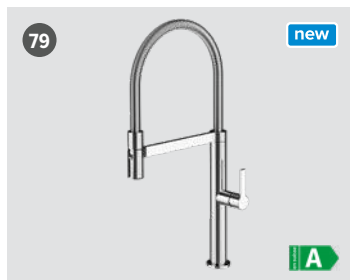

**i** Passende Dispenser und Zugknöpfe  
in allen Oberflächen auf den  
Seiten 363–369.  
Dispenser e pomoli abbinabili a tutte le superfici  
alle pagine 363–369.

Preis CHF/Prezzo in CHF

Name Nome	Modell Modello	Version/Oberfläche Versione/Superficie	Artikel-Nr. N. di articolo	Exkl. MWST IVA esclusa	Inkl. MWST IVA inclusa
79	Raio Profibrause Doccia professionale	Chrom Cromato	40.003.063.00 <b>L</b> H	685.–	740.–
80		* Edelstahl-Finish Acciaio inox-finish	40.003.064.00 <b>L</b> H	825.–	892.–
81		Pulverbeschichtung schwarz, matt Rivestimento con polvere nero, opaco	40.003.065.00 <b>L</b> H	825.–	892.–

\* Mit Metallschlauch / Con flessibile in metallo

**KWC** Exklusiv bei Suter / Un'esclusiva di Suter

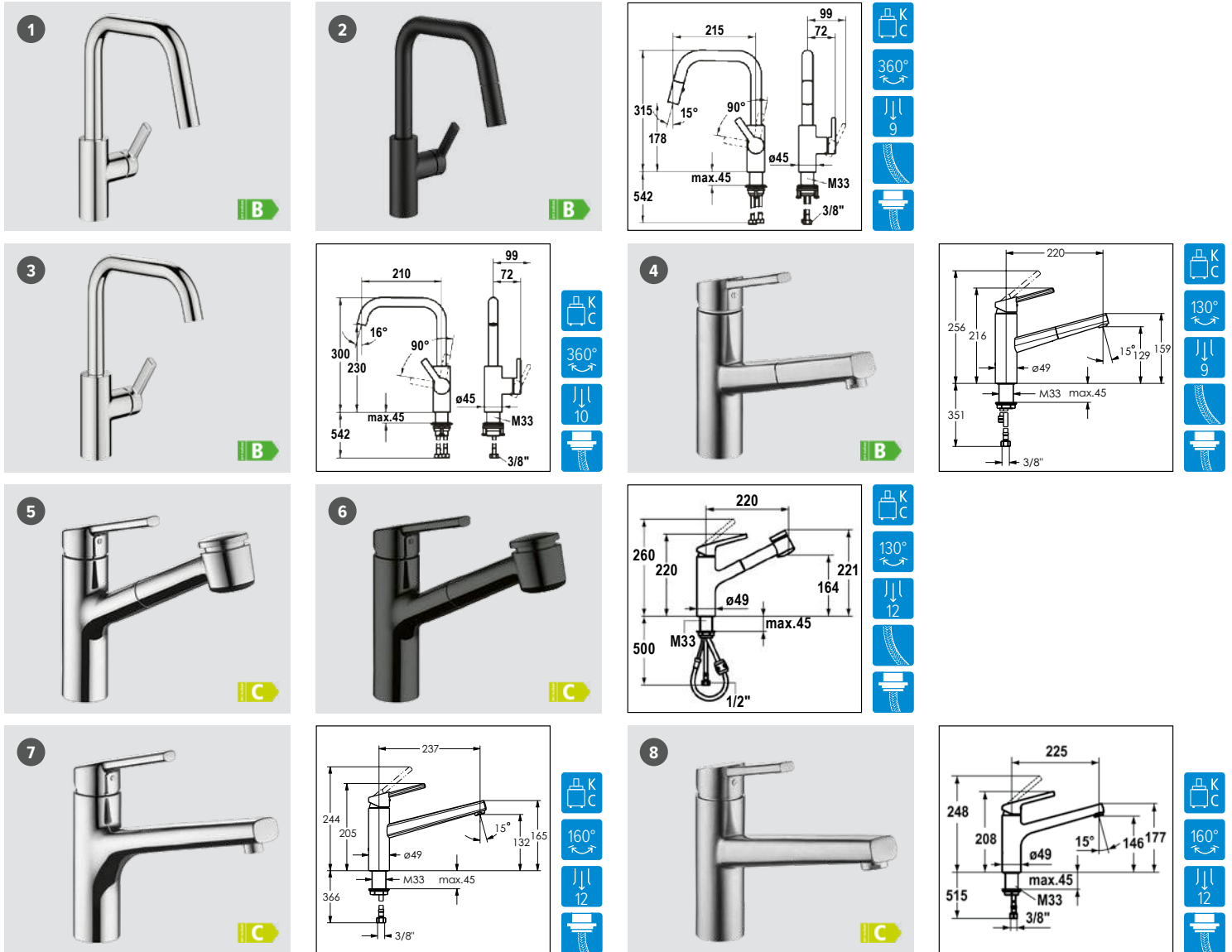

Preis CHF / Prezzo in CHF

Name Nome	Modell Modello	Version / Oberfläche Versione / Superficie	Artikel-Nr. N. di articolo	Exkl. MWST IVA esclusa	Inkl. MWST IVA inclusa
1 <b>Luna-E</b>	Auszugsbrause Doccia estraibile	Side lever L / Chrom Side lever L / Cromato	40.002.135.00 <b>L</b> G	424.-	458.-
		Side lever L / Pulverbeschichtung schwarz, matt Side lever L / Rivestimento con polvere nero, opaco	40.002.220.00 <b>L</b> G	603.-	652.-
3 <b>Luna-E</b>	Schwenkauslauf Braccio girevole	Side lever L / Chrom Side lever L / Cromato	40.002.134.00 <b>L</b> G	326.-	352.-
4 <b>Luna-E</b>	Zugauslauf Boccaglio estraibile	Top lever / Edelstahl, massiv Top lever / Acciaio inox, massiccio	40.001.721.00 <b>L</b> G	533.-	576.-
5 <b>Luna-E</b>	Auszugsbrause Doccia estraibile	Top lever / Chrom Top lever / Cromato	40.001.718.00 <b>L</b> G	402.-	435.-
		Top lever / Pulverbeschichtung schwarz, matt Top lever / Rivestimento con polvere nero, opaco	40.002.136.00 <b>L</b> G	537.-	580.-
7 <b>Luna-E</b>	Schwenkauslauf Braccio girevole	Top lever / Chrom Top lever / Cromato	40.001.720.00 <b>L</b> G	303.-	328.-
8 <b>Luna-E</b>	Schwenkauslauf Braccio girevole	Top lever / Edelstahl, massiv Top lever / Acciaio inox, massiccio	40.001.722.00 <b>L</b> G	432.-	467.-

☆ Mit Nylonschlauch / Con flessibile in nylon

# KWC

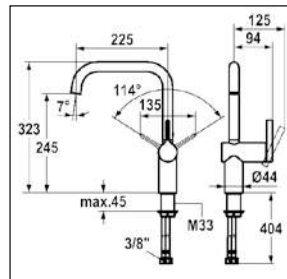
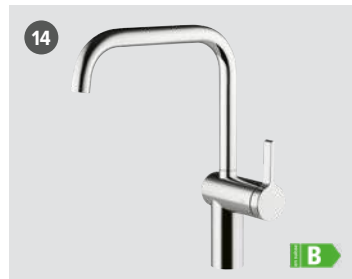
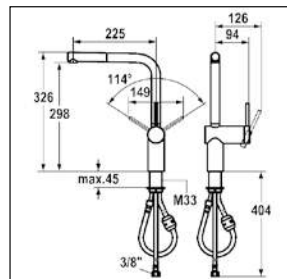
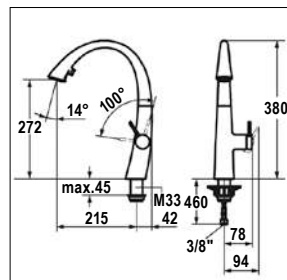
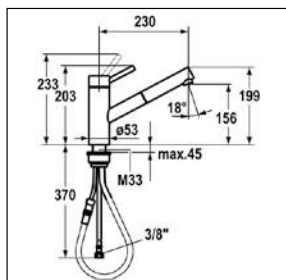

**i** Passende Dispenser und Zugknöpfe in allen Oberflächen auf den Seiten 363–369.  
Dispenser e pomoli abbinabili a tutte le superfici alle pagine 363–369.

Preis CHF/Prezzo in CHF

Name Nome	Modell Modello	Version/Oberfläche Versione/Superficie	KWC-Nr. N. di KWC	Artikel-Nr. N. di articolo	Exkl. MWST IVA esclusa	Inkl. MWST IVA inclusa
9 <b>Inox</b>	Zugauslauf Boccaglio estraibile	* Edelstahl, massiv Acciaio inox, massiccio	10.271.103.700FL	40.000.945.00 <b>L</b> C	886.–	958.–
10 <b>Zoe</b>	Auszugsbrause Doccia estraibile	* Chrom Cromato	10.201.102.000FL	40.001.996.00 <b>L</b> C	710.–	768.–
11		* Pulverbeschichtung schwarz, matt Rivestimento con polvere nero, opaco	10.201.102.176FL	40.002.140.00 <b>L</b> C	1063.–	1149.–
12 <b>Livello</b>	Zugauslauf Boccaglio estraibile	* Chrom Cromato	10.231.103.000FL	40.001.039.00 <b>L</b> G	587.–	635.–
13		* Edelstahl, massiv Acciaio inox, massiccio	10.231.103.700FL	40.001.041.00 <b>L</b> G	925.–	1000.–
14 <b>Livello</b>	Schwenkauslauf Braccio girevole	* Chrom Cromato	10.231.013.000FL	40.001.040.00 <b>L</b> G	506.–	547.–
15		* Edelstahl, massiv Acciaio inox, massiccio	10.231.013.700FL	40.001.042.00 <b>L</b> G	846.–	915.–

\* Mit Metallschlauch / Con flessibile in metallo

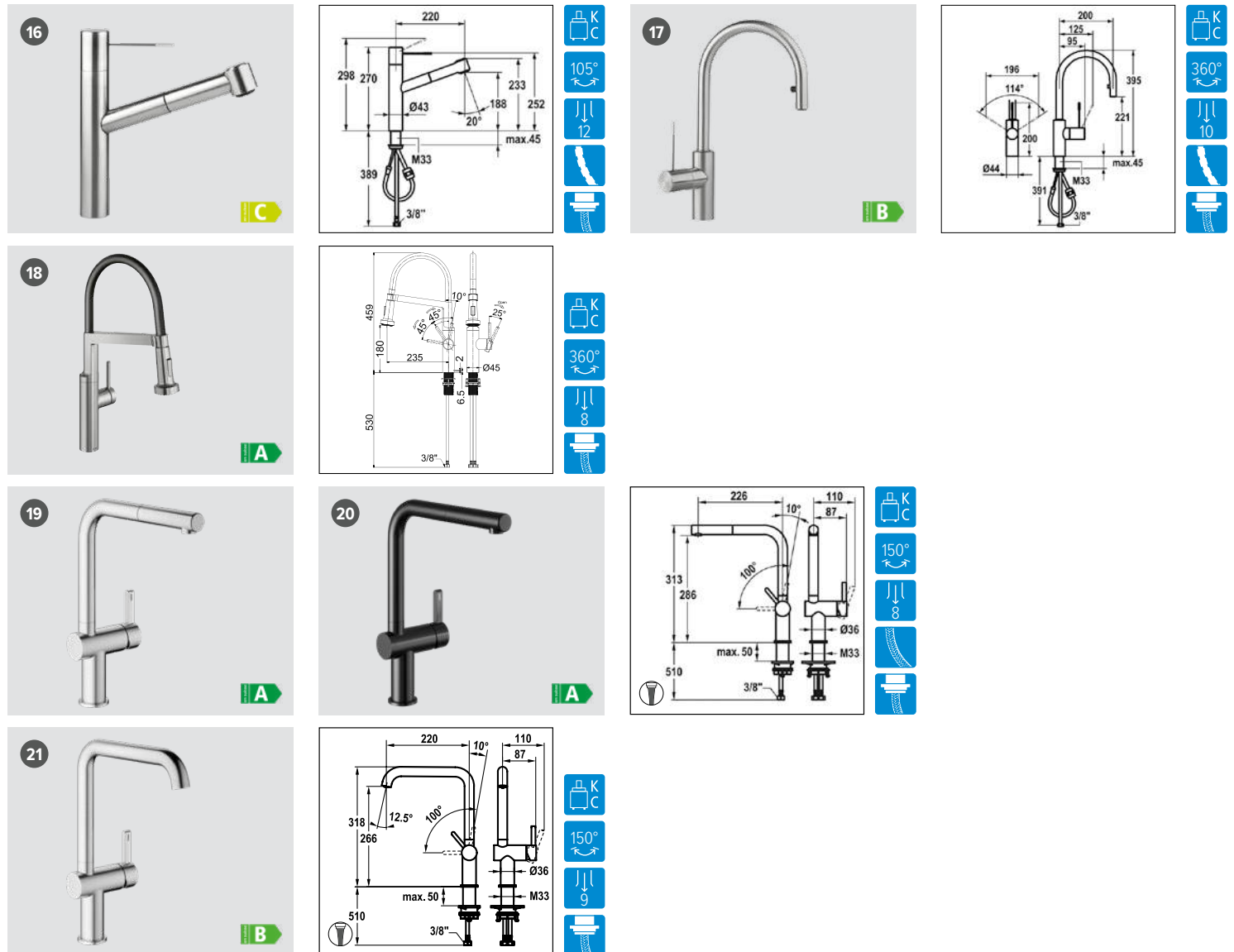

Preis CHF/Prezzo in CHF

	Name Nome	Modell Modello	Version/Oberfläche Versione/Superficie	KWC-Nr. N. di KWC	Artikel-Nr. N. di articolo	Exkl. MWST IVA esclusa	Inkl. MWST IVA inclusa
16	<b>Ono</b>	Auszugsbrause Doccia estraibile	* Top lever /Edelstahl, massiv Top lever /Acciaio inox, massiccio	10.151.033.700FL	40.000.942.00	C 978.–	1057.–
17	<b>Ono*</b>	Zugauslauf Boccaglio estraibile	* Side lever /Edelstahl, massiv Side lever /Acciaio inox, massiccio	10.151.102.700FL	40.000.944.00	C 968.–	1046.–
18	<b>Bistro E</b>	Profibrause Douchette professionale	Edelstahl, massiv Acciaio inox, massiccio	10.581.433.700FL	40.002.732.00	C 639.–	691.–
21	<b>Bevo</b>	Zugauslauf Boccaglio estraibile	Side lever /Edelstahl, massiv Side lever /Acciaio inox, massiccio	10.531.103.700FL	40.002.512.00	C 426.–	461.–
22		Side lever /PVD-Beschichtung, Inox Black Side lever /Rivestimento a PVD con Inox Black	10.531.103.751FL	40.002.513.00	C 595.–	643.–	
23	<b>Bevo</b>	Schwenkauslauf Braccio girevole	Side lever /Edelstahl, massiv Side lever /Acciaio inox, massiccio	10.531.012.700FL	40.002.514.00	C 323.–	349.–

\* Griffhebel rechts oder links /Leva a destra o a sinistra \* Mit Metallschlauch /Con flessibile in metallo ☆ Mit Nylonschlauch /Con flessibile in nylon Mit Laminarstrahl /Con getto laminare

# KWC

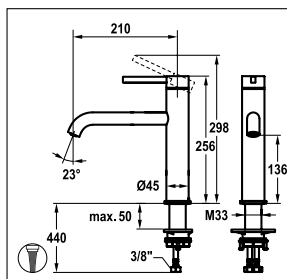
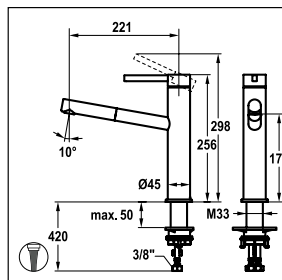
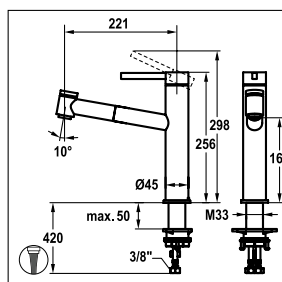

**i** Passende Dispenser und Zugknöpfe in allen Oberflächen auf den Seiten 363–369.  
Dispenser e pomoli abbinabili a tutte le superfici alle pagine 363–369.

Preis CHF/Prezzo in CHF

Name Nome	Modell Modello	Version / Oberfläche Versione / Superficie	KWC-Nr. N. di KWC	Artikel-Nr. N. di articolo	Exkl. MWST IVA esclusa	Inkl. MWST IVA inclusa
22 <b>Bevo</b>	Auszugsbrause Doccia estraibile	Top lever / Edelstahl, massiv Top lever / Acciaio inox, massiccio	10.531.032.700FL	40.002.506.00 <b>L</b>	C 413.–	446.–
		Top lever / PVD-Beschichtung, Inox Black Top lever / Rivestimento a PVD con Inox Black	10.531.032.751FL	40.002.507.00 <b>L</b>	C 578.–	625.–
24 <b>Bevo</b>	Zugauslauf Boccaglio estraibile	Top lever / Edelstahl, massiv Top lever / Acciaio inox, massiccio	10.531.112.700FL	40.002.508.00 <b>L</b>	C 385.–	416.–
		Top lever / PVD-Beschichtung, Inox Black Top lever / Rivestimento a PVD con Inox Black	10.531.112.751FL	40.002.509.00 <b>L</b>	C 538.–	582.–
26 <b>Bevo</b>	Schwenkauslauf Braccio girevole	Top lever / Edelstahl, massiv Top lever / Acciaio inox, massiccio	10.531.022.700FL	40.002.510.00 <b>L</b>	C 296.–	320.–

☆ Mit Nylonschlauch / Con flessibile in nylon    Ⓢ Mit Laminarstrahl / Con getto laminare

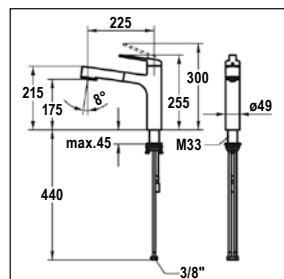
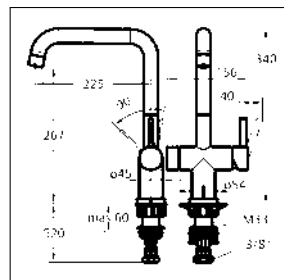
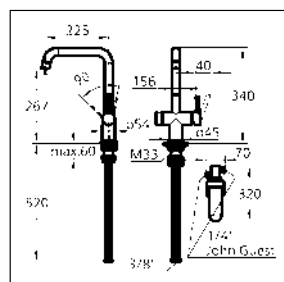

**i** \*Filterarmatur mit Starterkit, bestehend aus Armatur, Filterkopf und Filter (Filterstandzeit: ca. 1 Jahr). Ersatzfilter sind auf [kwc.ch](http://kwc.ch) bestellbar.  
 \*Raccordo filtro con starter kit, composto da raccordo, testa del filtro e filtro (durata del filtro: ca. 1 anno). I filtri di ricambio possono essere ordinati su [kwc.ch](http://kwc.ch).

\*\*Mögliche Verwendung: Bypass-Trinkwasserausgabe, zur Umgehung von Entkalkungsanlagen  
 \*\*Possibile impiego: erogatore di acqua potabile di bypass per eludere gli impianti di decalcificazione

Preis CHF/Prezzo in CHF

Name Nome	Modell Modello	Version/Oberfläche Versione/Superficie	KWC-Nr. N. di KWC	Artikel-Nr. N. di articolo	Exkl. MWST IVA esclusa	Inkl. MWST IVA inclusa
27	Enia E Filterarmatur mit Starterkit* Schwenkauslauf	Edelstahl, massiv	10.591.602.700FL	40.002.946.00	L C	700.-
28		Acciaio inox, massiccio	10.591.602.751FL	40.002.947.00	L C	757.-
29	Enia E Raccordo filtro con starter kit* Braccio girevole	Inox Black	10.591.612.700FL	40.002.948.00	L C	950.-
30		Inox Black	10.591.612.751FL	40.002.949.00	L C	1027.-
31	Domo Auszugsbrause Doccia estraibile	Edelstahl, massiv	10.591.612.700FL	40.002.948.00	L C	500.-
32		Acciaio inox, massiccio	10.591.612.751FL	40.002.949.00	L C	541.-
		Chrom	10.661.033.000FL	40.002.138.00	L C	750.-
		Cromato	10.661.033.000FL	40.002.138.00	L C	811.-
		* Edelstahl, massiv	10.701.033.700FL	40.002.221.00	L C	450.-
		Acciaio inox, massiccio	10.701.033.700FL	40.002.221.00	L C	486.-

\* Mit Metallschlauch / Con flessibile in metallo

# KWC

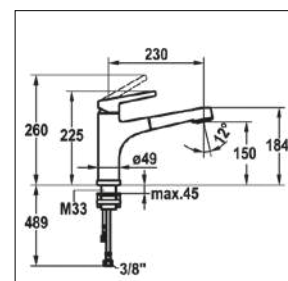
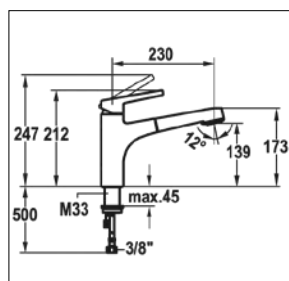
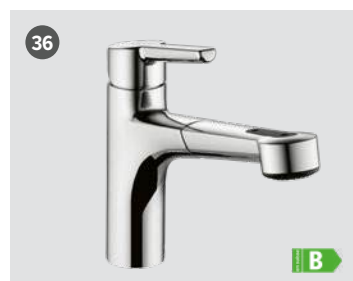
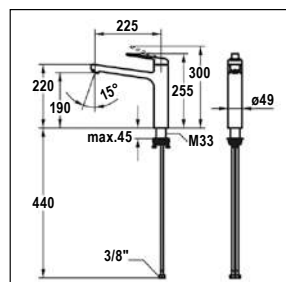
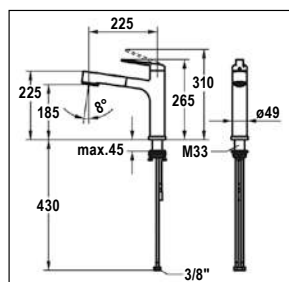

**i** Passende Dispenser und Zugknöpfe in allen Oberflächen auf den Seiten 363–369.  
Dispenser e pomoli abbinabili a tutte le superfici alle pagine 363–369.

Preis CHF/Prezzo in CHF

Name Nome	Modell Modello	Version/Oberfläche Versione/Superficie	KWC-Nr. N. di KWC	Artikel-Nr. N. di articolo	Exkl. MWST IVA esclusa	Inkl. MWST IVA inclusa
33 Domo Unterfenster Armatur Rubinetto sottofinestra	Auszugsbrause Höhe 60 mm* Doccia estraibile Altezza 60 mm*	* Chrom Cromato	10.661.053.000FL	40.002.139.00 L C	606.–	655.–
34 Domo	Schwenkauslauf Braccio girevole	Chrom Cromato	10.661.023.000FL	40.002.137.00 L C	319.–	345.–
35 Domo	Schwenkauslauf Braccio girevole	Edelstahl, massiv Acciaio inox, massiccio	10.701.023.700FL	40.002.222.00 L C	475.–	513.–
36 Suno	Auszugsbrause Doccia estraibile	☆ Chrom Cromato	10.171.033.000FL	40.001.993.00 L C	429.–	464.–
37 Suno Unterfenster- Armatur Rubinetto sottofi- nestra	Auszugsbrause Höhe 55 mm* Doccia estraibile Altezza 55 mm*	☆ Chrom Cromato	10.171.053.000FL	40.001.994.00 L C	578.–	625.–

\* Verbleibende Höhe in gekipptem Zustand / Altezza in posizione basculante \* Mit Metallschlauch / Con flessibile in metallo ☆ Mit Nylonschlauch / Con flessibile in nylon

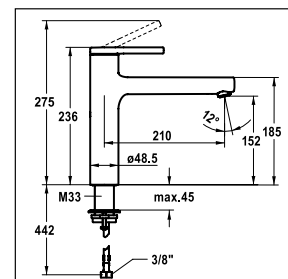
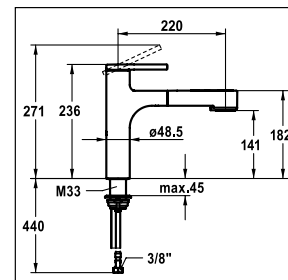
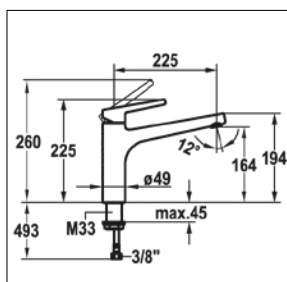

Preis CHF/Prezzo in CHF

Name Nome	Modell Modello	Version / Oberfläche Versione / Superficie	KWC-Nr. N. di KWC	Artikel-Nr. N. di articolo	Exkl. MWST IVA esclusa	Inkl. MWST IVA inclusa
38	Suno	Schwenkauslauf Braccio girevole	Chrom Cromato	10.171.023.000FL	40.001.995.00	306.– / 331.–
39			Chrom Cromato	10.461.032.000FL	40.002.516.00	410.– / 443.–
40	Ava	Auszugsbrause Doccia estraibile	* Edelstahl-Finish Acciaio inox-finish	10.461.032.177FL	40.002.723.00	552.– / 597.–
41			Pulverbeschichtung schwarz, matt Rivestimento con polvere nero, opaco	10.461.032.176FL	40.002.724.00	552.– / 597.–
42			Chrom Cromato	10.461.022.000FL	40.002.517.00	293.– / 317.–
43	Ava	Schwenkauslauf Braccio girevole	Edelstahl-Finish Acciaio inox-finish	10.461.022.177FL	40.002.721.00	395.– / 427.–
44			Pulverbeschichtung schwarz, matt Rivestimento con polvere nero, opaco	10.461.022.176FL	40.002.722.00	395.– / 427.–

\* Mit Metallschlauch / Con flessibile in metallo

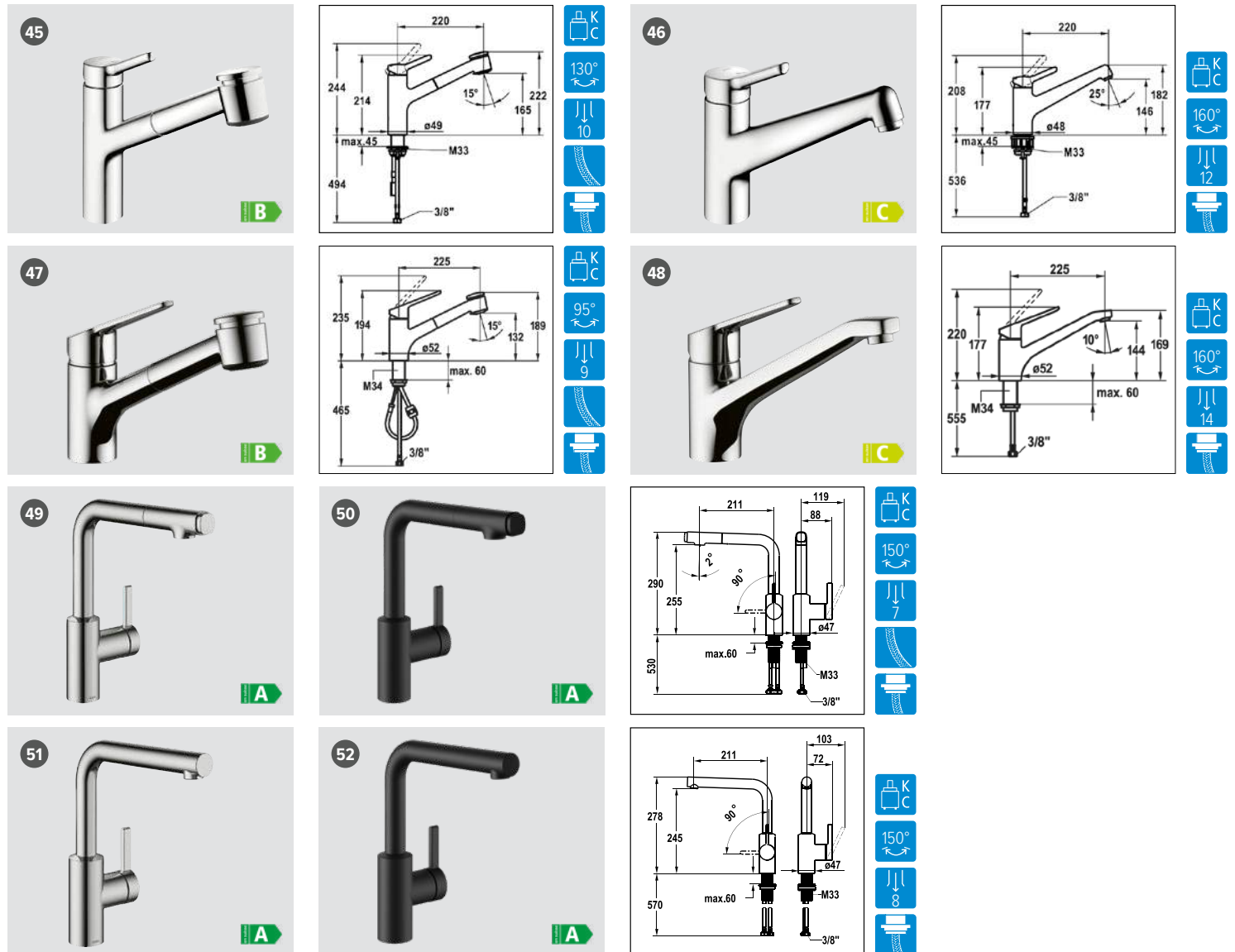
**KWC**

Preis CHF/Prezzo in CHF

Name Nome	Modell Modello	Version / Oberfläche Versione / Superficie	KWC-Nr. N. di KWC	Artikel-Nr. N. di articolo	Exkl. MWST IVA esclusa	Inkl. MWST IVA inclusa
45	<b>Wamas</b> Auszugsbrause Doccia estraibile	☆ Chrom Cromato	10.471.032.000FL	40.002.730.00	L C 365.–	395.–
46	<b>Wamas</b> Schwenkauslauf Braccio girevole	Chrom Cromato	10.471.022.000FL	40.002.729.00	L C 268.–	290.–
47	<b>Isla</b> Auszugsbrause Doccia estraibile	☆ Chrom Cromato	10.371.033.000FL	40.001.991.00	L C 293.–	317.–
48	<b>Isla</b> Schwenkauslauf Braccio girevole	Chrom Cromato	10.371.023.000FL	40.001.992.00	L C 194.–	210.–
49	<b>Fit</b> Auszugsbrause Doccia estraibile	Side lever / Chrom Side lever / Cromato	10.541.002.000FL	40.002.728.00	L C 240.–	259.–
50		☆ Side lever / Pulverbeschichtung schwarz, matt Side lever / Rivestimento con polvere nero, opaco	10.541.002.176FL	40.002.954.00	L C 324.–	350.–
51	<b>Fit</b> Schwenkauslauf Braccio girevole	Side lever / Chrom Side lever / Cromato	10.541.012.000FL	40.002.727.00	L C 172.–	186.–
52		☆ Side lever / Pulverbeschichtung schwarz, matt Side lever / Rivestimento con polvere nero, opaco	10.541.012.176FL	40.002.953.00	L C 232.–	251.–

☆ Mit Nylonschlauch / Con flessibile in nylon

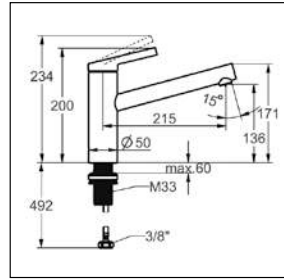
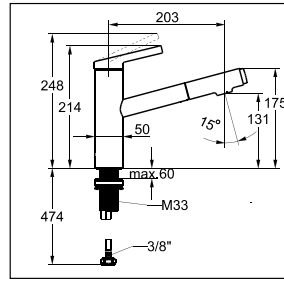

**i** Passende Dispenser und Zugknöpfe in allen Oberflächen auf den Seiten 363–369.  
 Dispenser e pomoli abbinabili a tutte le superfici alle pagine 363–369.

**Preis CHF/Prezzo in CHF**

Name Nome	Modell Modello	Version / Oberfläche Versione / Superficie	KWC-Nr. N. di KWC	Artikel-Nr. N. di articolo	Exkl. MWST IVA esclusa	Inkl. MWST IVA inclusa
53 <b>Fit</b>	Auszugsbrause Doccia estraibile	Top lever / Chrom Top lever / Cromato	10.541.032.000FL	40.002.726.00 <b>L</b> C	219.–	237.–
		☆ Top lever / Pulverbeschichtung schwarz, matt Top lever / Rivestimento con polvere nero, opaco	10.541.032.176FL	40.002.952.00 <b>L</b> C	295.–	319.–
55 <b>Fit</b>	Schwenkauslauf Braccio girevole	Top lever / Chrom Top lever / Cromato	10.541.022.000FL	40.002.725.00 <b>L</b> C	156.–	169.–
		Top lever / Pulverbeschichtung schwarz, matt Top lever / Rivestimento con polvere nero, opaco	10.541.022.176FL	40.002.951.00 <b>L</b> C	212.–	229.–

☆ Mit Nylonschlauch / Con flessibile in nylon

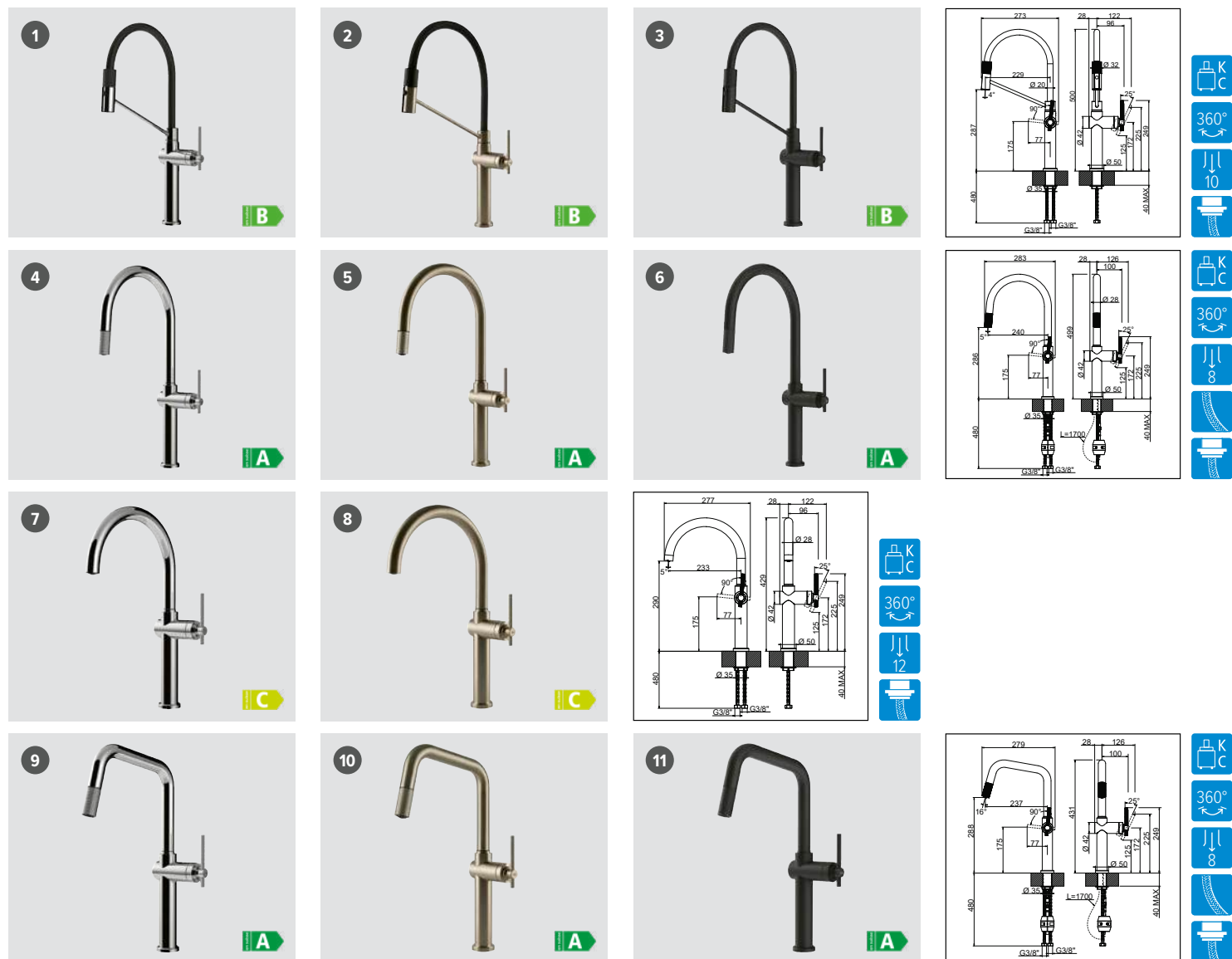

**Preis CHF / Prezzo in CHF**

	Name Nome	Modell Modello	Version / Oberfläche Versione / Superficie	Gessi-Nr. N. di Gessi	Artikel-Nr. N. di articolo	Exkl. MWST IVA esclusa	Inkl. MWST IVA inclusa
1	<b>Segno</b>	Profibrause Doccia professionale	Chrom	60664.031	40.002.754.00	L H	961.-
2			Edelstahl-Finish	60664.149	40.002.755.00	L H	1083.-
3			Acciaio inox-finish	60664.299	40.002.756.00	L H	1083.-
4	<b>Segno</b>	Zugauslauf Boccaglio estraibile	Side lever C / Chrom	60672.031	40.002.751.00	L H	776.-
5			Side lever C / Cromato	60672.149	40.002.752.00	L H	915.-
6			Side lever C / Pulverbeschichtung schwarz, matt	60672.299	40.002.753.00	L H	915.-
7	<b>Segno</b>	Schwenkauslauf Braccio girevole	Side lever C / Chrom	60670.031	40.002.748.00	L H	633.-
8			Side lever C / Cromato	60670.149	40.002.749.00	L H	761.-
9	<b>Segno</b>	Zugauslauf Boccaglio estraibile	Side lever U / Chrom	60652.031	40.002.745.00	L H	761.-
10			Side lever U / Cromato	60652.149	40.002.746.00	L H	905.-
11			Side lever U / Pulverbeschichtung schwarz, matt	60652.299	40.002.747.00	L H	905.-

☆ Mit Nylonschlauch / Con flessibile in nylon

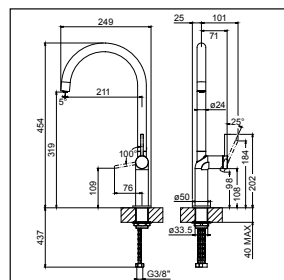
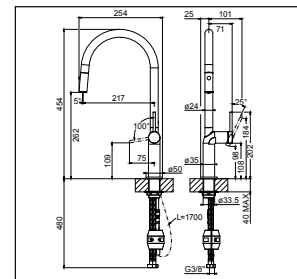
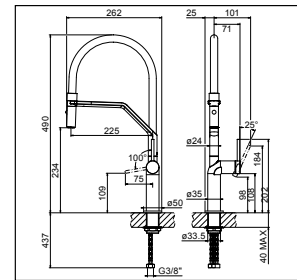
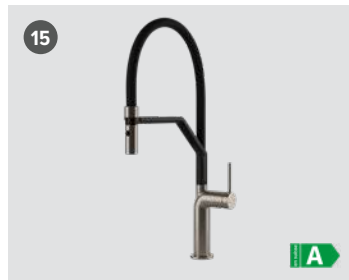
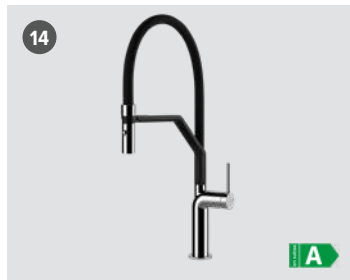
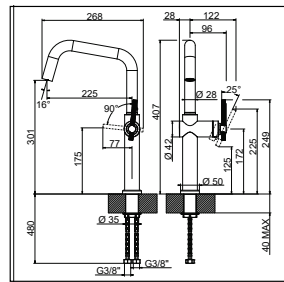

Exklusiv bei Suter / Un'esclusiva di Suter



**i** Passende Dispenser und Zugknöpfe in allen Oberflächen auf den Seiten 363–369.  
Dispenser e pomoli abbinabili a tutte le superfici alle pagine 363–369.

Preis CHF / Prezzo in CHF

	Name Nome	Modell Modello	Version / Oberfläche Versione / Superficie	Gessi-Nr. N. di Gessi	Artikel-Nr. N. di articolo	Exkl. MWST IVA esclusa	Inkl. MWST IVA inclusa
12	Segno	Schwenkauslauf Braccio girevole	Side lever U / Chrom	60650.031	40.002.742.00	L H 610.–	659.–
13			Side lever U / Cromato	60650.149	40.002.743.00	L H 735.–	795.–
14	Stelo	Profibrause Doccia professionale	Chrom	60315.031	40.002.119.00	L H 734.–	793.–
15			Edelstahl-Finish	60315.149	40.002.120.00	L H 838.–	906.–
16			Pulverbeschichtung schwarz, matt Rivestimento con polvere nero, opaco	60315.299	40.002.121.00	L H 838.–	906.–
17	Stelo	Auszugsbrause Doccia estraibile	Side lever C / Chrom	60303.031	40.002.106.00	L H 551.–	596.–
18			Side lever C / Cromato	60303.149	40.002.107.00	L H 692.–	748.–
19			Side lever C / Edelstahl-Finish Side lever C / Acciaio inox-finish	60303.299	40.002.108.00	L H 692.–	748.–
20	Stelo	Schwenkauslauf Braccio girevole	Side lever C / Chrom	60301.031	40.002.104.00	L H 403.–	436.–
21			Side lever C / Cromato Side lever C / Edelstahl-Finish Side lever C / Acciaio inox-finish	60301.149	40.002.105.00	L H 512.–	553.–

☆ Mit Nylonschlauch / Con flessibile in nylon

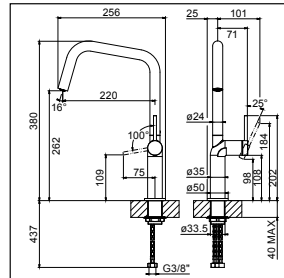
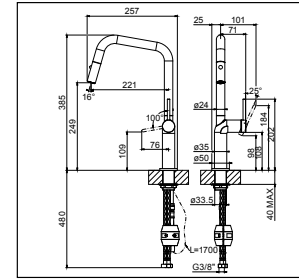
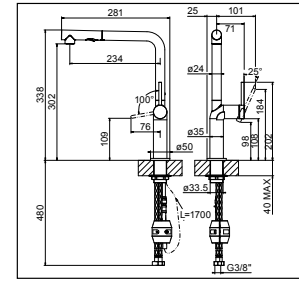

**i** Passende Dispenser und Zugknöpfe in allen Oberflächen auf den Seiten 363–369.  
Dispenser e pomoli abbinabili a tutte le superfici alle pagine 363–369.

**Preis CHF / Prezzo in CHF**

	Name Nome	Modell Modello	Version / Oberfläche Versione / Superficie	Gessi-Nr. N. di Gessi	Artikel-Nr. N. di articolo	Exkl. MWST IVA esclusa	Inkl. MWST IVA inclusa
22			Side lever L / Chrom Side lever L / Cromato	60311.031	40.002.116.00 <b>L</b> H	499.–	539.–
23	<b>Stelo</b>	Auszugsbrause Doccia estraibile	☆ Side lever L / Edelstahl-Finish Side lever L / Acciaio inox-finish	60311.149	40.002.117.00 <b>L</b> H	633.–	684.–
24			Side lever L / Pulverbeschichtung schwarz, matt Side lever L / Rivestimento con polvere nero, opaco	60311.299	40.002.118.00 <b>L</b> H	633.–	684.–
25				Side lever U / Chrom Side lever U / Cromato	60307.031	40.002.111.00 <b>L</b> H	551.–
26	<b>Stelo</b>	Auszugsbrause Doccia estraibile	☆ Side lever U / Edelstahl-Finish Side lever U / Acciaio inox-finish	60307.149	40.002.112.00 <b>L</b> H	692.–	748.–
27			Side lever U / Pulverbeschichtung schwarz, matt Side lever U / Rivestimento con polvere nero, opaco	60307.299	40.002.113.00 <b>L</b> H	692.–	748.–
28				Side lever U / Chrom Side lever U / Cromato	60305.031	40.002.109.00 <b>L</b> H	389.–
29	<b>Stelo</b>	Schwenkauslauf Braccio girevole	Side lever U / Edelstahl-Finish Side lever U / Acciaio inox-finish	60305.149	40.002.110.00 <b>L</b> H	512.–	553.–

☆ Mit Nylonschlauch / Con flessibile in nylon



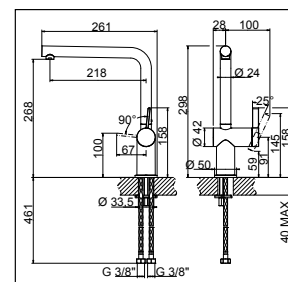
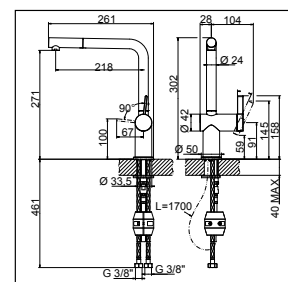

**i** Passende Dispenser und Zugknöpfe in allen Oberflächen auf den Seiten 363–369.  
Dispenser e pomoli abbinabili a tutte le superfici alle pagine 363–369.

**Preis CHF/Prezzo in CHF**

Name Nome	Modell Modello	Version / Oberfläche Versione / Superficie	Gessi-Nr. N. di Gessi	Artikel-Nr. N. di articolo	Exkl. MWST IVA esclusa	Inkl. MWST IVA inclusa	
35	Zugauslauf Boccaglio estraibile	Chrom Cromato	60617.031	40.002.424.00	L H	448.–	484.–
36		Edelstahl-Finish Acciaio inox-finish	60617.149	40.002.425.00	L H	540.–	584.–
37		Pulverbeschichtung schwarz, matt Rivestimento con polvere nero, opaco	60617.299	40.002.426.00	L H	540.–	584.–
38	Schwenkauslauf Braccio girevole	Chrom Cromato	60615.031	40.002.421.00	L H	363.–	392.–
39		Edelstahl-Finish Acciaio inox-finish	60615.149	40.002.422.00	L H	458.–	495.–
40		Pulverbeschichtung schwarz, matt Rivestimento con polvere nero, opaco	60615.299	40.002.423.00	L H	458.–	495.–

☆ Mit Nylonschlauch / Con flessibile in nylon

\* Modell ist mit Befestigungs-Set mit Befestigungsbügel (Hufeisen) ausgerüstet. Bei der Montage die mitgelieferte Verstärkungsplatte (Dreieck) verwenden.  
\* Il modello è dotato di set di fissaggio con staffa di fissaggio (a forma di ferro di cavallo). Utilizzare la piastra di rinforzo in dotazione (triangolo) per il montaggio.

LAUFEN **Exklusiv bei Suter/Un'esclusiva di Suter**

Laufen Vara Epoc: Multifunktionsarmatur/Rubinetteria multifunzionale

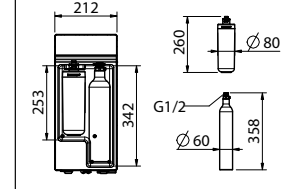
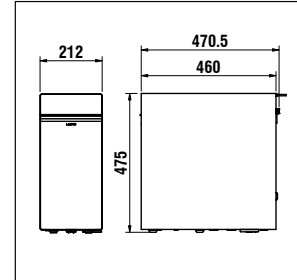
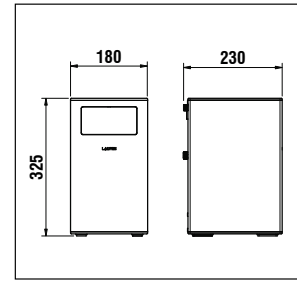
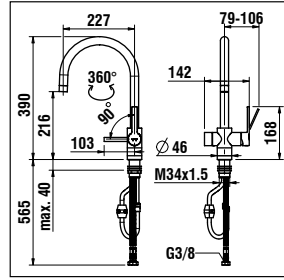
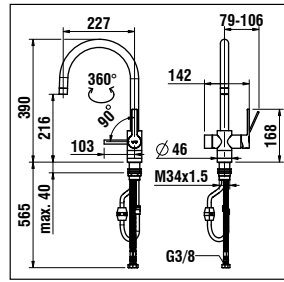
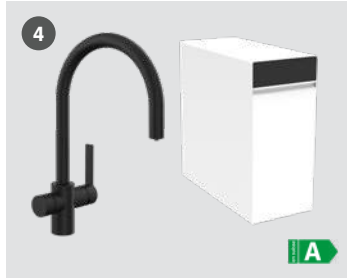
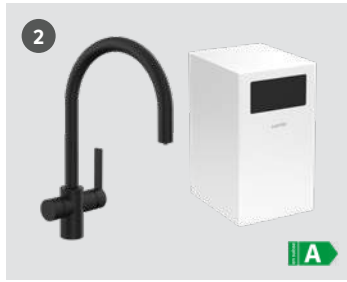

- Laufen Vara Epoc All in One liefert kochend heisses, sprudelndes, gekühltes und gefiltertes Wasser
- Ersatzfilter und CO<sub>2</sub>-Zylinder sind online bestellbar via [www.laufen-vara.ch](http://www.laufen-vara.ch). Alternativ passt auch der Standard-Zylinder von Soda Stream mit 425 g oder alle sodastreamkompatiblen CO<sub>2</sub>-Zylinder mit Schraubverschluss (Quick Connector passt nicht)
- Standzeit Wasserfilter Laufen Ultra ca. 1/2 Jahr, der Soda Fresh CO<sub>2</sub>-Zylinder Maxi reicht für ca. 60 Liter Sprudelwasser
- Beide Systeme benötigen einen Stromanschluss, 230V, Absicherung 10A
- Wartung: Um eine stetige Wasserqualität zu erreichen, empfehlen wir die jährliche professionelle Wartung des Vara Systems durch Laufen. Siehe Angebote via [laufen-vara.ch](http://laufen-vara.ch)
- Mehr Infos, Datenblätter, etc. siehe [suter.ch](http://suter.ch).
- Laufen Vara Epoc All in One eroga acqua bollente, frizzante, fredda e filtrata
- I filtri di ricambio e le bombole di CO<sub>2</sub> possono essere ordinati online sul sito [www.laufen-vara.ch](http://www.laufen-vara.ch). In alternativa, è possibile utilizzare la bombola standard di Soda Stream da 425 g o tutte le bombole di CO<sub>2</sub> compatibili con Soda Stream con tappo a vite (Quick Connector non è adatto)
- La durata utile del filtro dell'acqua Laufen Ultra è di circa 3 anni e mezzo, la bombola Soda Fresh CO<sub>2</sub> Maxi è sufficiente per circa 60 litri di acqua frizzante
- Entrambi i sistemi richiedono una presa elettrica, 230V, protezione 10A
- Manutenzione: al fine di garantire una qualità dell'acqua costante, consigliamo una manutenzione professionale annuale del sistema Vara da parte di Laufen. Le offerte sono disponibili su [laufen-vara.ch](http://laufen-vara.ch).
- Pubblicheremo maggiori informazioni, vedi [suter.ch](http://suter.ch).

**!** Montageservice: Bei Inanspruchnahme des Montageservice von Laufen Schweiz für die Multifunktionsarmaturen Vara Epoc bestellen Sie **bitte die Artikel-Nr. mit Endziffer .80 und zusätzlich den gewünschten Montageserviceartikel auf Seite 346 Bildhinweisnummer 5.**  
 Montaggio da parte: In caso di utilizzo del servizio di montaggio da parte di Laufen Svizzera per le rubinetterie multifunzionali Vara Epoc, **si prega di ordinare gli articoli con cifra finale .80 e in aggiunta con l'articolo del servizio d'installazione desiderato a pagina 346 riferimento immagine numero 5.**

Preis CHF/Prezzo in CHF

Name Nome	Modell Modello	Version / Oberfläche Versione / Superficie	Artikel-Nr. N. di articolo		Exkl. MWST IVA esclusa	Inkl. MWST IVA inclusa	VRG TRA
1 <b>Vara Epoc Hot</b>	Heisswasserarmatur mit Zugauslauf Rubinetteria per acqua calda con boccaglio estraibile	Edelstahl, massiv Acciaio inox, massiccio	40.002.982.00	L G	1790.-	1935.-	3.11
		Bei Inanspruchnahme des Montageservice durch Laufen Schweiz**/*** In caso di utilizzo del servizio di montaggio da parte di Laufen Svizzera**/***	40.002.982.80	G	1790.-	1935.-	3.11
		Inox Black Inox Black	40.002.983.00	L G	1990.-	2151.-	3.11
		Bei Inanspruchnahme des Montageservice durch Laufen Schweiz**/*** In caso di utilizzo del servizio di montaggio da parte di Laufen Svizzera**/***	40.002.983.80	G	1990.-	2151.-	3.11
3 <b>Vara Epoc All in One</b>	Multifunktionsarmatur mit Zugauslauf (im Lieferumfang ist der Soda Fresh CO <sub>2</sub> -Zylinder Maxi und der Wasserfilter Laufen Ultra enthalten) Rubinetteria multifunzionale con boccaglio estraibile (la bombola Soda Fresh CO <sub>2</sub> Maxi e il filtro Laufen Ultra sono compresi nel corredo di fornitura)	Edelstahl, massiv Acciaio inox, massiccio	40.002.984.00	L G	3075.-	3324.-	7.51
		Bei Inanspruchnahme des Montageservice durch Laufen Schweiz**/*** In caso di utilizzo del servizio di montaggio da parte di Laufen Svizzera**/***	40.002.984.80	G	3075.-	3324.-	7.51
		Inox Black Inox Black	40.002.985.00	L G	3275.-	3540.-	7.51
		Bei Inanspruchnahme des Montageservice durch Laufen Schweiz**/*** In caso di utilizzo del servizio di montaggio da parte di Laufen Svizzera**/***	40.002.985.80	G	3275.-	3540.-	7.51

☆ Mit Nylonschlauch / Con flessibile in nylon

\* Preis ohne Montageservice/\*\* Termine nach Absprache (die Durchlaufzeit für einen Montageauftrag beträgt ca. 20 Arbeitstage)

\* Prezzo senza servizio di montaggio/\*\* Appuntamento previo accordo (i tempi di esecuzione per un ordine di montaggio sono di circa 20 giorni lavorativi)

## Laufen Vara Epoc: Serviceleistungen und Zubehör/ Servizi e accessori

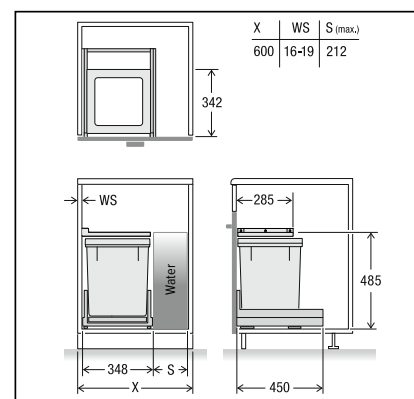

- i**
- Sparen Sie Zeit und reduzieren Sie das Fehlerrisiko, indem Sie vom Montageservice von Laufen Schweiz profitieren. Wir empfehlen diese Serviceleistung grundsätzlich immer zu beanspruchen.
  - Dadurch verlängert sich die Garantie automatisch um 1 Jahr auf insgesamt 3 Jahre.
  - Für die Montage von Laufen Vara Epoc muss die Küche siphoniert, das Becken montiert, Frisch- und Abwasseranschluss installiert und funktionsfähig und der Stromanschluss (230V, Absicherung 10A) sichergestellt sein.
  - Risparmiate tempo e riducete il rischio di commettere errori usufruendo del servizio di montaggio di Laufen Svizzera. Vi consigliamo di avvalervi sempre di questo servizio.
  - In questo modo, il periodo di garanzia si estende automaticamente da 1 anno a un totale di 3 anni.
  - Per il montaggio di Laufen Vara Epoc è necessario che la cucina sia dotata di un sifone, che il lavello sia montato, che l'allacciamento all'acqua fresca e lo scarico siano installati e funzionanti e che sia disponibile una presa elettrica (230V, protezione 10A).

**!** Montageservice: Bei Inanspruchnahme des Montageservice von Laufen Schweiz für das System Müllex X40 L35 Vara bestellen Sie **bitte die Artikel-Nr. mit Endziffer .80 und zusätzlich den gewünschten Montageserviceartikel aus Bildhinweisnummer 5.**  
 Montaggio da parte: In caso di utilizzo del servizio di montaggio da parte di Laufen Svizzera per il sistema Müllex X40 L35 Vara, **si prega di ordinare gli articoli con cifra finale .80 e in aggiunta con l'articolo del servizio d'installazione desiderato dal riferimento immagine numero 5.**

Preis CHF/Prezzo in CHF

Name Nome	Beschreibung Descrizione	Artikel-Nr. N. di articolo		Exkl. MWST IVA esclusa	Inkl. MWST IVA inclusa
5	Montageservice Laufen Vara Epoc Hot durch Laufen Schweiz Servizio di montaggio di Laufen Vara Epoc Hot da parte di Laufen Svizzera	825.000.000.80	N	310.–	335.–
	Montageservice Laufen Vara Epoc All in One durch Laufen Schweiz Servizio di montaggio di Laufen Vara Epoc All in One da parte di Laufen Svizzera	825.000.001.80	N	450.–	486.–
	Montageservice Müllex X40 L35 Vara durch Laufen Schweiz Servizio di montaggio di Müllex X40 L35 Vara da parte di Laufen Svizzera	825.000.002.80	N	120.–	130.–
6 <b>Müllex X40 L35 Vara</b>	Schmales Komplettsystem für Küchenunterschranke mit seitlich installierten Multifunktionsarmaturen Laufen Vara Epoc. Die Montage kann rechts oder links erfolgen. Bestehend aus: 40 Liter Hauptbehälter, Ablagedeckel seitlich fix und Komplettschubkasten Pro. Korpusbreite 600mm Piccolo cassetto completo per mobili da cucina con rubinetterie multifunzionali Laufen Vara Epoc installate lateralmente. Può essere installato a destra o a sinistra. Composto da: contenitore principale da 40 litri, coperchio di contenimento laterale fisso e cassetto completo Pro. Larghezza modulo 600 mm	40.002.935.00	L G	315.–	341.–
	Bei Inanspruchnahme des Montageservice durch Laufen Schweiz <sup>*/**</sup> In caso di utilizzo del servizio di montaggio da parte di Laufen Svizzera <sup>*/**</sup>	40.002.935.80	G	315.–	341.–

\* Preis ohne Montageservice / \*\* Termine nach Absprache (die Durchlaufzeit für einen Montageauftrag beträgt ca. 20 Arbeitstage)

\* Prezzo senza servizio di montaggio / \*\* Appuntamento previo accordo (i tempi di esecuzione per un ordine di montaggio sono di circa 20 giorni lavorativi)

LAUFEN **Exklusiv bei Suter/Un'esclusiva di Suter**

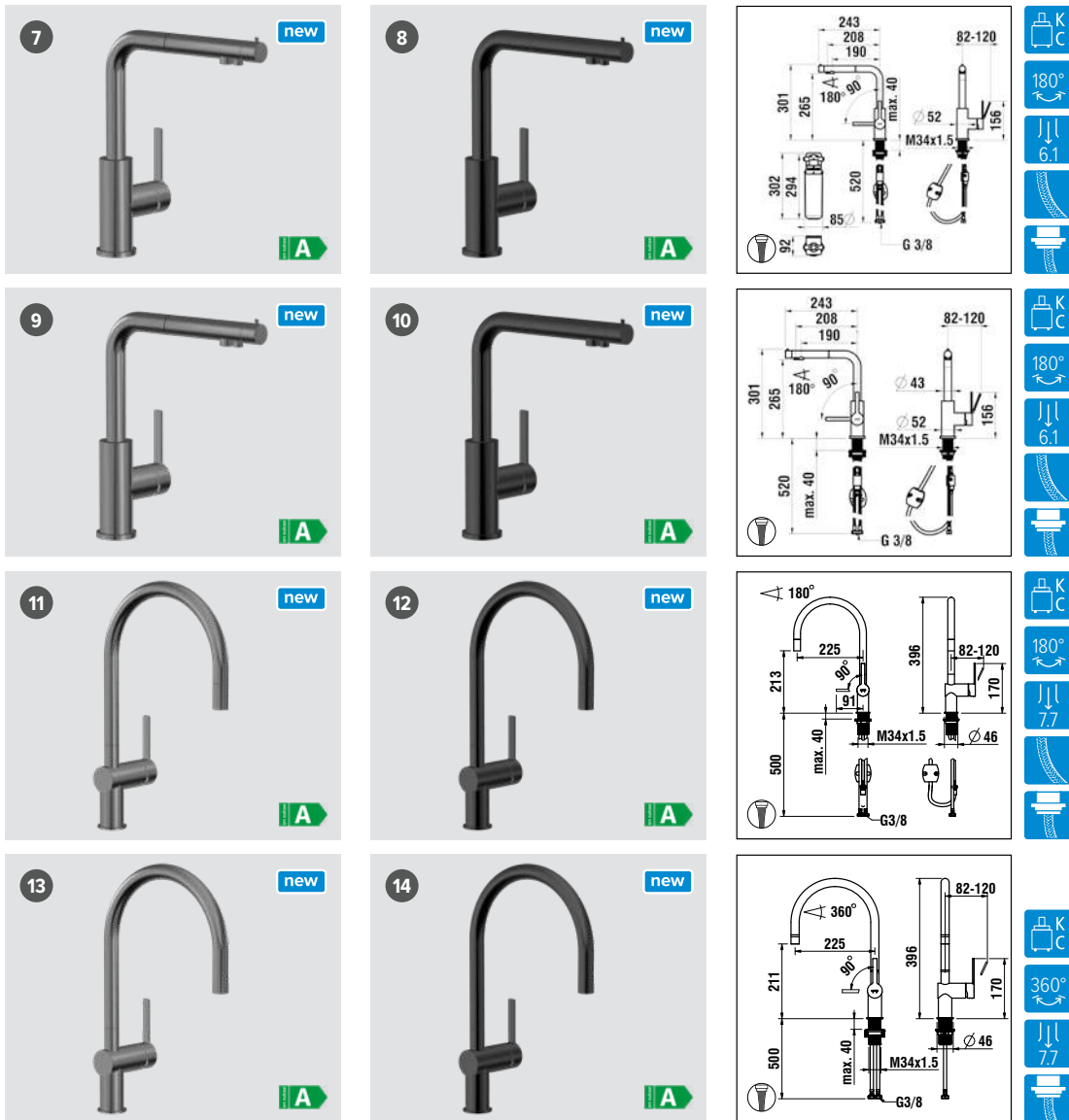

**i** \*Filterarmatur mit Starterkit, bestehend aus Armatur, Filterkopf und Filter Laufen Ultra. Ersatzfilter sind online bestellbar via laufen-vara.ch  
 \*Raccordo filtro con starter kit, composto da raccordo, testa del filtro e filtro Laufen Ultra. I filtri di ricambio possono essere ordinati online su laufen-vara.ch.

\*\*Mögliche Verwendung: Bypass-Trinkwasserausgabe, zur Umgehung von Entkalkungsanlagen  
 \*\*Possibile impiego: erogatore di acqua potabile di bypass per eludere gli impianti di decalcificazione

**Preis CHF/Prezzo in CHF**

Name Nome	Modell Modello	Version/Oberfläche Versione/Superficie	Artikel-Nr. N. di articolo	Exkl. MWST IVA esclusa	Inkl. MWST IVA inclusa
7 <b>Lico</b>	Filterarmatur mit Starterkit* Zugauslauf Raccordo filtro con starter kit* Boccaglio estraibile	Edelstahl, massiv Acciaio inox, massiccio	40.003.043.00 <b>L</b>	G 765.–	827.–
		PVD-Beschichtung, Inox Black Rivestimento a PVD, Inox Black	40.003.044.00 <b>L</b>	G 915.–	989.–
9 <b>Lico</b>	Bypassarmatur Zugauslauf* Raccordo bypass** Boccaglio estraibile	Edelstahl, massiv Acciaio inox, massiccio	40.003.045.00 <b>L</b>	G 635.–	686.–
		PVD-Beschichtung, Inox Black Rivestimento a PVD, Inox Black	40.003.046.00 <b>L</b>	G 785.–	849.–
11 <b>Kiano</b>	Zugauslauf Boccaglio estraibile	Side lever C/Edelstahl, massiv Side lever C/Acciaio inox, massiccio	40.003.035.00 <b>L</b>	G 438.–	473.–
		Side lever C/PVD-Beschichtung, Inox Black Side lever C/Rivestimento a PVD, Inox Black	40.003.036.00 <b>L</b>	G 520.–	562.–
13 <b>Kiano</b>	Schwenkauslauf Braccio girevole	Side lever C/Edelstahl, massiv Side lever C/Acciaio inox, massiccio	40.003.037.00 <b>L</b>	G 336.–	363.–
		Side lever C/PVD-Beschichtung, Inox Black Side lever C/Rivestimento a PVD, Inox Black	40.003.038.00 <b>L</b>	G 398.–	430.–

☆ Mit Nylonschlauch / Con flessibile in nylon    Ⓞ Mit Laminarstrahl / Con getto laminare

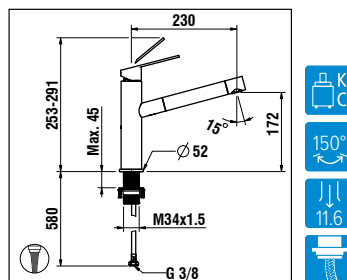
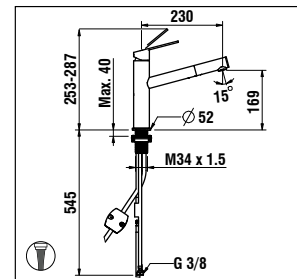
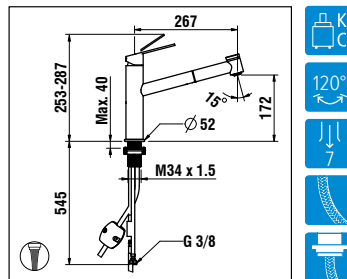
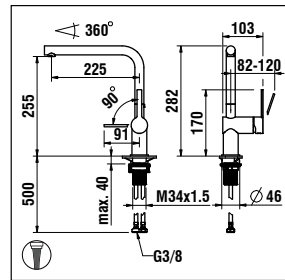
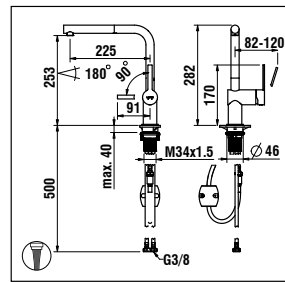
LAUFEN **Exklusiv bei Suter/Un'esclusiva di Suter**

**i** Passende Dispenser und Zugknöpfe in allen Oberflächen auf den Seiten 363–369.  
Dispenser e pomoli abbinabili a tutte le superfici alle pagine 363–369.

Preis CHF/Prezzo in CHF

Name Nome	Modell Modello	Version / Oberfläche Versione / Superficie	Artikel-Nr. N. di articolo	Exkl. MWST IVA esclusa	Inkl. MWST IVA inclusa
15 <b>Kiano</b>	Zugauslauf Boccaglio estraibile	Side lever L / Edelstahl, massiv Side lever L / Acciaio inox, massiccio	40.003.039.00 <b>L</b>	G 438.–	473.–
		Side lever L / PVD-Beschichtung, Inox Black Side lever L / Rivestimento a PVD, Inox Black	40.003.040.00 <b>L</b>	G 520.–	562.–
17 <b>Kiano</b>	Schwenkauslauf Braccio girevole	Side lever L / Edelstahl, massiv Side lever L / Acciaio inox, massiccio	40.003.041.00 <b>L</b>	G 336.–	363.–
		Side lever L / PVD-Beschichtung, Inox Black Side lever L / Rivestimento a PVD, Inox Black	40.003.042.00 <b>L</b>	G 398.–	430.–
19 <b>Kiano</b>	Auszugsbrause Doccia estraibile	Top lever / Edelstahl, massiv Top lever / Acciaio inox, massiccio	40.003.032.00 <b>L</b>	G 395.–	427.–
20 <b>Kiano</b>	Zugauslauf Boccaglio estraibile	Top lever / Edelstahl, massiv Top lever / Acciaio inox, massiccio	40.003.033.00 <b>L</b>	G 355.–	384.–
21 <b>Kiano</b>	Schwenkauslauf Braccio girevole	Top lever / Edelstahl, massiv Top lever / Acciaio inox, massiccio	40.003.034.00 <b>L</b>	G 295.–	319.–

☆ Mit Nylonschlauch / Con flessibile in nylon    Ⓞ Mit Laminarstrahl / Con getto laminare

LAUFEN **Exklusiv bei Suter/Un'esclusiva di Suter**

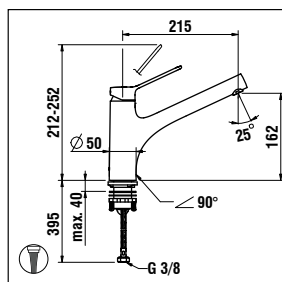
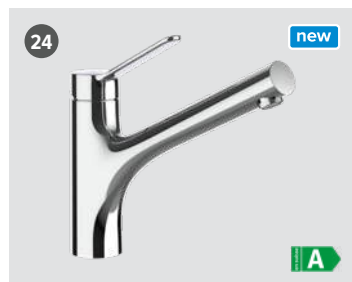
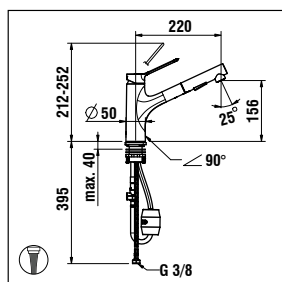
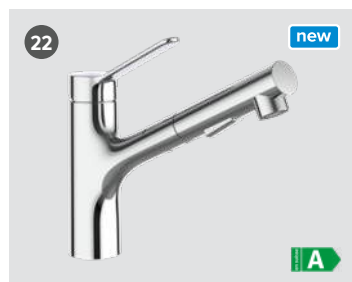

		Preis CHF/Prezzo in CHF					
Name Nome	Modell Modello	Version/Oberfläche Versione/Superficie	Artikel-Nr. N. di articolo	Exkl. MWST IVA esclusa	Inkl. MWST IVA inclusa		
22 <b>Eleo</b>	Auszugsbrause Doccia estraibile	Chrom Cromato	40.003.028.00	G	268.-	290.-	
		Pulverbeschichtung schwarz, matt Rivestimento con polvere nero, opaco	40.003.029.00	G	328.-	355.-	
24 <b>Eleo</b>	Schwenkauslauf Braccio girevole	Chrom Cromato	40.003.030.00	G	198.-	214.-	
		Pulverbeschichtung schwarz, matt Rivestimento con polvere nero, opaco	40.003.031.00	G	258.-	279.-	

☆ Mit Nylonschlauch / Con flessibile in nylon Mit Laminarstrahl / Con getto laminare

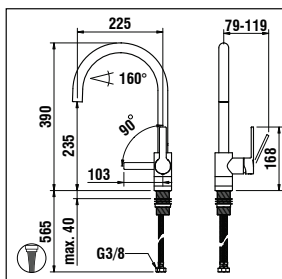
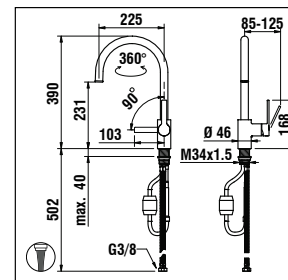
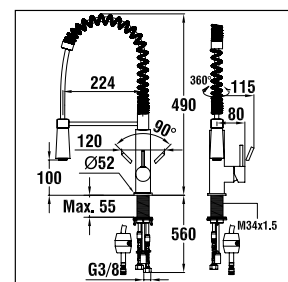
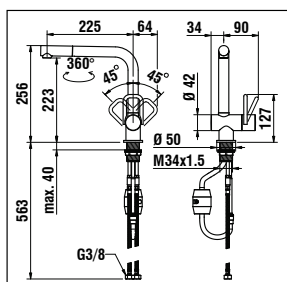
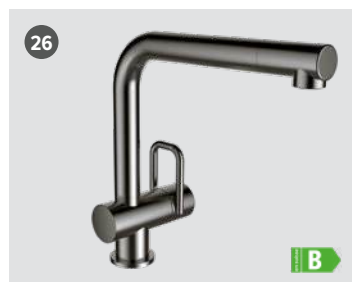
LAUFEN **Exklusiv bei Suter/Un'esclusiva di Suter**

**i** Passende Dispenser und Zugknöpfe in allen Oberflächen auf den Seiten 363–369.  
Dispenser e pomoli abbinabili a tutte le superfici alle pagine 363–369.

Preis CHF/Prezzo in CHF

Name Nome	Modell Modello	Version/Oberfläche Versione/Superficie	Artikel-Nr. N. di articolo	Exkl. MWST IVA esclusa	Inkl. MWST IVA inclusa
26 <b>Twin*</b>	Zugauslauf Boccaglio estraibile	☆ PVD-Beschichtung, Graphit Rivestimento a PVD, grafite	40.001.270.00 <b>L</b>	C 1095.–	1184.–
27 <b>Sento</b>	Pendelauslauf Bocca oscillante	* Side lever/Edelstahl, massiv Side lever/Acciaio inox, massiccio	40.001.299.00 <b>L</b>	G 984.–	1064.–
28		Side lever C/Chrom Side lever C/Cromato	40.002.225.00 <b>L</b>	G 470.–	508.–
29 <b>Epoc</b>	Zugauslauf Boccaglio estraibile	Ⓜ☆ Side lever C/Edelstahl, massiv Side lever C/Acciaio inox, massiccio	40.002.226.00 <b>L</b>	G 879.–	950.–
30		Side lever C/PVD-Beschichtung, Inox Black Side lever C, rivestimento a PVD, Inox Black	40.002.505.00 <b>L</b>	G 991.–	1071.–
31 <b>Epoc</b>	Schwenkauslauf Braccio girevole	Ⓜ Side lever C/Chrom Side lever C/Cromato	40.002.227.00 <b>L</b>	G 427.–	462.–
32		Side lever C/Edelstahl, massiv Side lever C/Acciaio inox, massiccio	40.002.228.00 <b>L</b>	G 834.–	902.–

\* Griffhebel rechts oder links / Leva a destra o a sinistra \* Mit Metallschlauch / Con flessibile in metallo ☆ Mit Nylonschlauch / Con flessibile in nylon Ⓜ Mit Laminarstrahl / Con getto laminare

LAUFEN **Exklusiv bei Suter/Un'esclusiva di Suter**

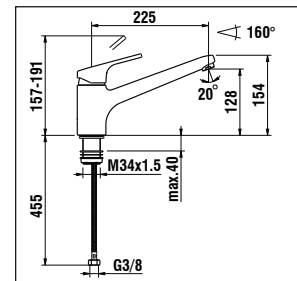
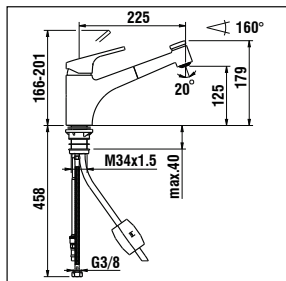
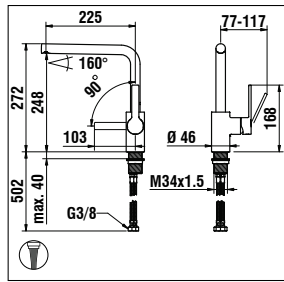
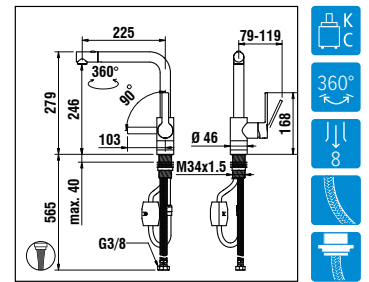

Preis CHF/Prezzo in CHF

Name Nome	Modell Modello	Version/Oberfläche Versione/Superficie	Artikel-Nr. N. di articolo	Exkl. MWST IVA esclusa	Inkl. MWST IVA inclusa
33	Epoc Auszugsbrause Doccia estraibile	Chrom Cromato	40.001.655.00	G 555.-	600.-
34		Edelstahl, massiv Acciaio inox, massiccio	40.001.729.00	G 881.-	952.-
35		PVD-Beschichtung, Inox Black Rivestimento a PVD, Inox Black	40.002.504.00	G 1009.-	1091.-
36	Epoc Schwenkauslauf Braccio girevole	Chrom Cromato	40.001.656.00	G 446.-	482.-
37		Edelstahl, massiv Acciaio inox, massiccio	40.001.730.00	G 718.-	776.-
38	Pino Auszugsbrause Doccia estraibile	Chrom Cromato	40.001.975.00	G 362.-	391.-
39	Pino Schwenkauslauf Braccio girevole	Chrom Cromato	40.001.976.00	G 217.-	235.-

☆ Mit Nylonschlauch/Con flessibile in nylon Mit Laminarstrahl/Con getto laminare

## LAUFEN

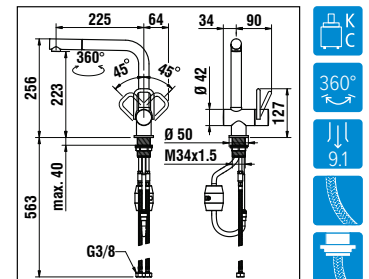
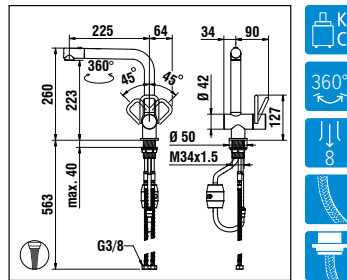
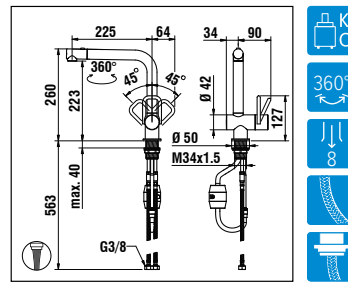

**i** Passende Dispenser und Zugknöpfe  
in allen Oberflächen auf den  
Seiten 363–369.  
Dispenser e pomoli abbinabili a tutte le superfici  
alle pagine 363–369.

Preis CHF/Prezzo in CHF

Name Nome	Modell Modello	Version/Oberfläche Versione/Superficie	Laufen-Nr. N. di Laufen	Artikel-Nr. N. di articolo	Exkl. MWST IVA esclusa	Inkl. MWST IVA inclusa	
40	Twin* Auszugsbrause Doccia estraibile	Edelstahl, massiv Acciaio inox, massiccio	HF989683441001	40.001.456.00	L C	889.–	961.–
41		PVD-Beschichtung, Inox Black Rivestimento a PVD, Inox Black	HF989683448001	40.002.522.00	L C	1080.–	1167.–
42	Twin S* Auszugsbrause Doccia estraibile	Edelstahl, massiv, mit Struktur Acciaio inox, massiccio, con struttura	HF989683A41001	40.002.737.00	L C	991.–	1071.–
43	Twin* Unter- fenster-Armatur Rubinetto sottofinestra	Zugauslauf Boccaglio estraibile Höhe 155mm** Altezza 155mm**	Chrom Cromato	HF989673100001	L C	546.–	590.–
44	Twin* Unter- fenster-Armatur Rubinetto sottofinestra	Zugauslauf Boccaglio estraibile Höhe 155mm** Altezza 155mm**					
45	Twin* Zugauslauf Boccaglio estraibile	PVD-Beschichtung, Inox Black Rivestimento a PVD, Inox Black	HF989693448000	40.002.523.00	L C	1065.–	1151.–

\* Griffhebel rechts oder links / Leva a destra o a sinistra \*\* Verbleibende Höhe in gekipptem Zustand / Altezza in posizione basculante ☆ Mit Nylonschlauch / Con flessibile in nylon ① Mit Laminarstrahl / Con getto laminare

LAUFEN

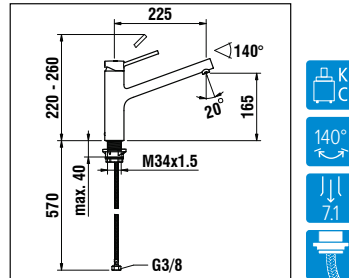
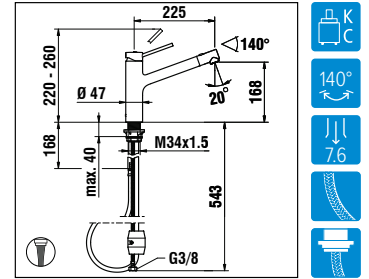
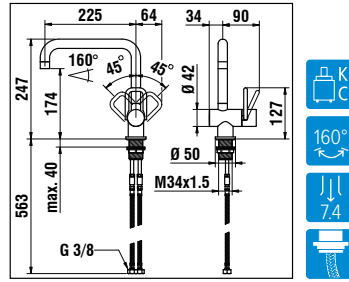

Preis CHF/Prezzo in CHF

Name Nome	Modell Modello	Version / Oberfläche Versione / Superficie	Laufen-Nr. N. di Laufen	Artikel-Nr. N. di articolo	Exkl. MWST IVA esclusa	Inkl. MWST IVA inclusa
46	Twin*	Chrom Cromato	HF989532100001	40.000.223.00	449.-	485.-
47		Edelstahl, massiv Acciaio inox, massiccio	HF989552441001	40.001.339.00	711.-	769.-
48	Twinplus	Chrom Cromato	HF905437100000	40.001.980.00	532.-	575.-
49		Edelstahl, massiv Acciaio inox, massiccio	HF905437441000	40.002.142.00	696.-	752.-
50		PVD-Beschichtung, Inox Black Rivestimento a PVD, Inox Black	HF905437448000	40.002.525.00	835.-	903.-
51	Twinplus	Chrom Cromato	HF905432100000	40.001.981.00	441.-	477.-
52		Edelstahl, massiv Acciaio inox, massiccio	HF905432441000	40.002.143.00	605.-	654.-

\* Griffhebel rechts oder links / Leva a destra o a sinistra ☆ Mit Nylonschlauch / Con flessibile in nylon ⓘ Mit Laminarstrahl / Con getto laminare

## LAUFEN

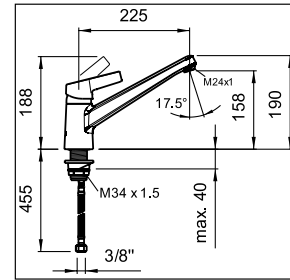
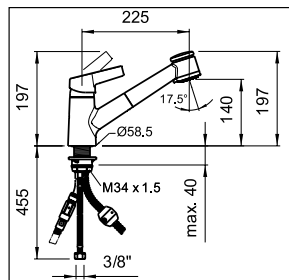
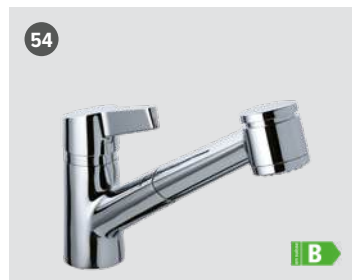
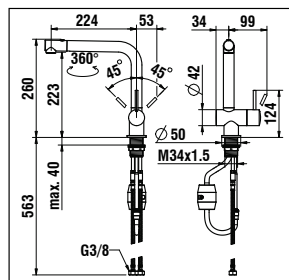

**i** Passende Dispenser und Zugknöpfe in allen Oberflächen auf den Seiten 363–369.

Dispenser e pomoli abbinabili a tutte le superfici alle pagine 363–369.

Preis CHF/Prezzo in CHF

Name Nome	Modell Modello	Version/Oberfläche Versione/Superficie	Laufen-Nr. N. di Laufen	Artikel-Nr. N. di articolo	Exkl. MWST IVA esclusa	Inkl. MWST IVA inclusa
53 Triathlon*	Auszugsbrause Doccia estraibile	☆ Edelstahl, massiv Acier inox, massif	HF502136441000	40.001.143.00 <b>L</b> C	1030.–	1113.–
54 Swap	Auszugsbrause Doccia estraibile	☆ Chrom Cromato	HF501809100000	40.000.946.00 <b>L</b> C	428.–	463.–
55 Swap	Schwenkauslauf Braccio girevole	Chrom Cromato	HF501800100000	40.000.947.00 <b>L</b> C	286.–	309.–

\* Griffhebel rechts oder links / Leva a destra o a sinistra ☆ Mit Nylonschlauch / Con flessibile in nylon



# hansgrohe

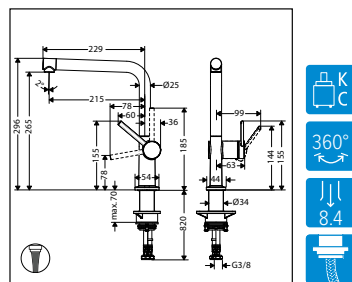
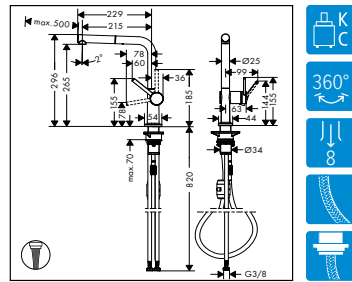

Preis CHF/Prezzo in CHF

	Name Nome	Modell Modello	Version / Oberfläche Versione / Superficie	Hansgrohe-Nr. N. di Hansgrohe	Artikel-Nr. N. di articolo	Exkl. MWST IVA esclusa	Inkl. MWST IVA inclusa	
5	<b>Talis M54</b>	Zugauslauf Boccaglio estraibile	Side lever L / Chrom Side lever L / Cromato	72808000	40.002.147.00	L C	294.–	318.–
6			Side lever L / Edelstahl-Finish Side lever L / Acciaio inox-finish	72808800	40.002.148.00	L C	377.–	408.–
7			Side lever L / PVD-Beschichtung, Graphit Side lever L / Rivestimento a PVD, grafite	72808340	40.002.544.00	L C	404.–	437.–
8			Side lever L / Nasslackierung schwarz, seidenglanz Side lever L / Laccato all'acqua nero, satinato lucido	72808670	40.002.149.00	L C	377.–	408.–
9	<b>Talis M54</b>	Schwenkauslauf Braccio girevole	Side lever L / Chrom Side lever L / Cromato	72840000	40.002.150.00	L C	254.–	275.–
10			Side lever L / Edelstahl-Finish Side lever L / Acciaio inox-finish	72840800	40.002.151.00	L C	325.–	351.–
11			Side lever L / PVD-Beschichtung, Graphit Side lever L / Rivestimento a PVD, grafite	72840340	40.002.545.00	L C	348.–	376.–
12			Side lever L / Nasslackierung schwarz, seidenglanz Side lever L / Laccato all'acqua nero, satinato lucido	72840670	40.002.152.00	L C	325.–	351.–

☆ Mit Nylonschlauch / Con flessibile in nylon    Ⓢ Mit Laminarstrahl / Con getto laminare

**hansgrohe**

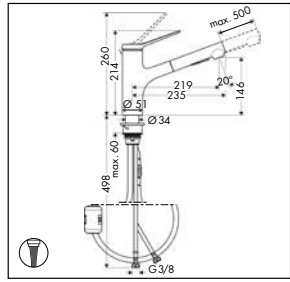

K C  
 150°  
 8.2

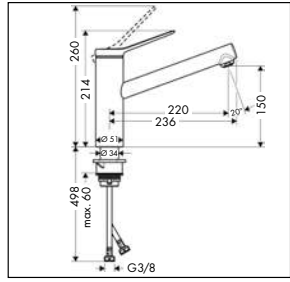

K C  
 360°  
 11.6

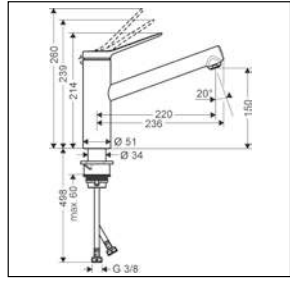

K C  
 110°  
 7.6

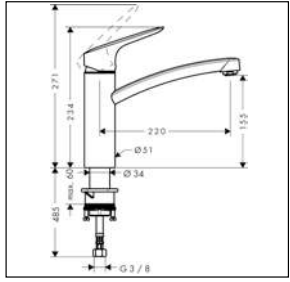

K C  
 360°  
 12

**i** Passende Dispenser und Zugknöpfe in allen Oberflächen auf den Seiten 363–369.  
 Dispenser e pomoli abbinabili a tutte le superfici alle pagine 363–369.

**Preis CHF/Prezzo in CHF**

Name Nome	Modell Modello	Version / Oberfläche Versione / Superficie	Hansgrohe-Nr. N. di Hansgrohe	Artikel-Nr. N. di articolo	Exkl. MWST IVA esclusa	Inkl. MWST IVA inclusa
13 <b>Zesis</b> <b>M33-150</b>	Auszugsbrause Doccia estraibile	Chrom Cromato	74800000	40.002.427.00	L C	210.– 227.–
14		Edelstahl-Finish Acciaio inox-finish	74800800	40.002.428.00	L C	272.– 294.–
15 <b>Zesis</b> <b>M33-150</b>	Schwenkauslauf Braccio girevole	Chrom Cromato	74802000	40.002.429.00	L C	153.– 165.–
16		Edelstahl-Finish Acciaio inox-finish	74802800	40.002.430.00	L C	197.– 213.–
17 <b>Zesis</b> <b>M33-150</b>	Schwenkauslauf Braccio girevole	Chrom Cromato	74813000	40.002.757.00	L C	153.– 165.–
18 <b>CoolStart*</b>		Edelstahl-Finish Acciaio inox-finish	74813800	40.002.758.00	L C	197.– 213.–
19 <b>Logis</b>	Schwenkauslauf Braccio girevole	Chrom Cromato	71832000	40.001.672.00	L C	148.– 160.–

\* Kaltbebelstellung Mitte / Leva del freddo in posizione centrale ☆ Mit Nylonschlauch / Con flessibile in nylon ⓘ Mit Laminarstrahl / Con getto laminare

DORN  
BRACHT

Exklusiv bei Suter/Un'esclusiva di Suter

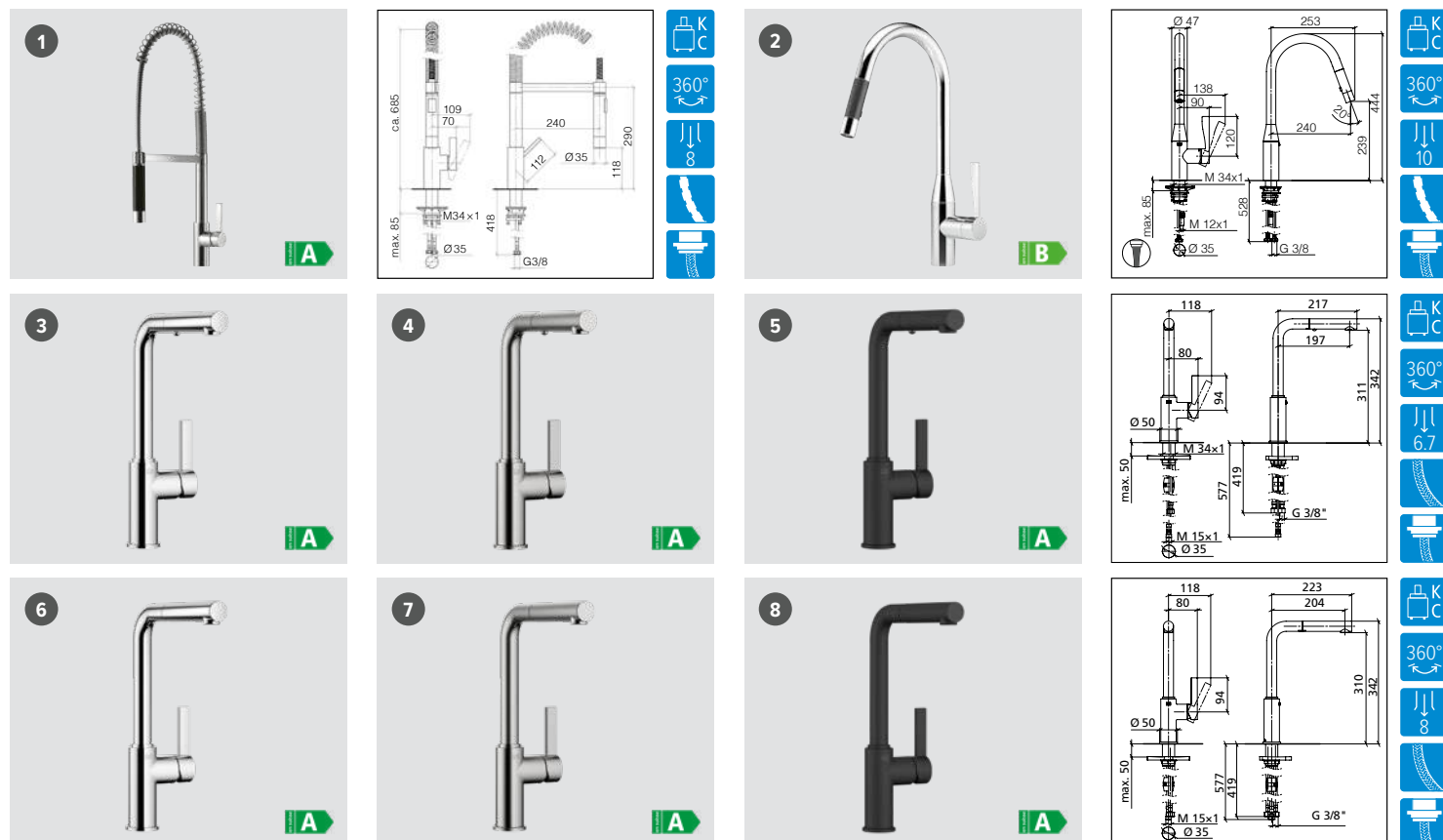

Preis CHF/Prezzo in CHF

Name Nome	Modell Modello	Version / Oberfläche Versione / Superficie	Artikel-Nr. N. di articolo	Exkl. MWST IVA esclusa	Inkl. MWST IVA inclusa
1 Tara Ultra	Profibrausengarnitur Doccia professionale	* Ice	40.001.576.00	2263.–	2446.–
2 Sync	Auszugsbrause Doccia estraibile	① * Ice	40.001.665.00	1427.–	1543.–
3		Side lever L / Chrom Side lever L / Cromato	40.002.475.00	430.–	465.–
4 Koya	Auszugsbrause Doccia estraibile	☆ Side lever L / Edelstahl-Finish Side lever L / Acciaio inox-finish	40.002.476.00	539.–	583.–
5		Side lever L / Pulverbeschichtung schwarz, matt Side lever L / Rivestimento con polvere nero, opaco	40.002.477.00	539.–	583.–
6		Side lever L / Chrom Side lever L / Cromato	40.002.472.00	359.–	388.–
7 Koya	Zugauslauf Boccaglio estraibile	☆ Side lever L / Edelstahl-Finish Side lever L / Acciaio inox-finish	40.002.473.00	470.–	508.–
8		Side lever L / Pulverbeschichtung schwarz, matt Side lever L / Rivestimento con polvere nero, opaco	40.002.474.00	470.–	508.–

\* Mit Metallschlauch / Con flessibile in metallo ☆ Mit Nylonschlauch / Con flessibile in nylon ① Mit Laminarstrahl / Con getto laminare



Exklusiv bei Suter/Un'esclusiva di Suter

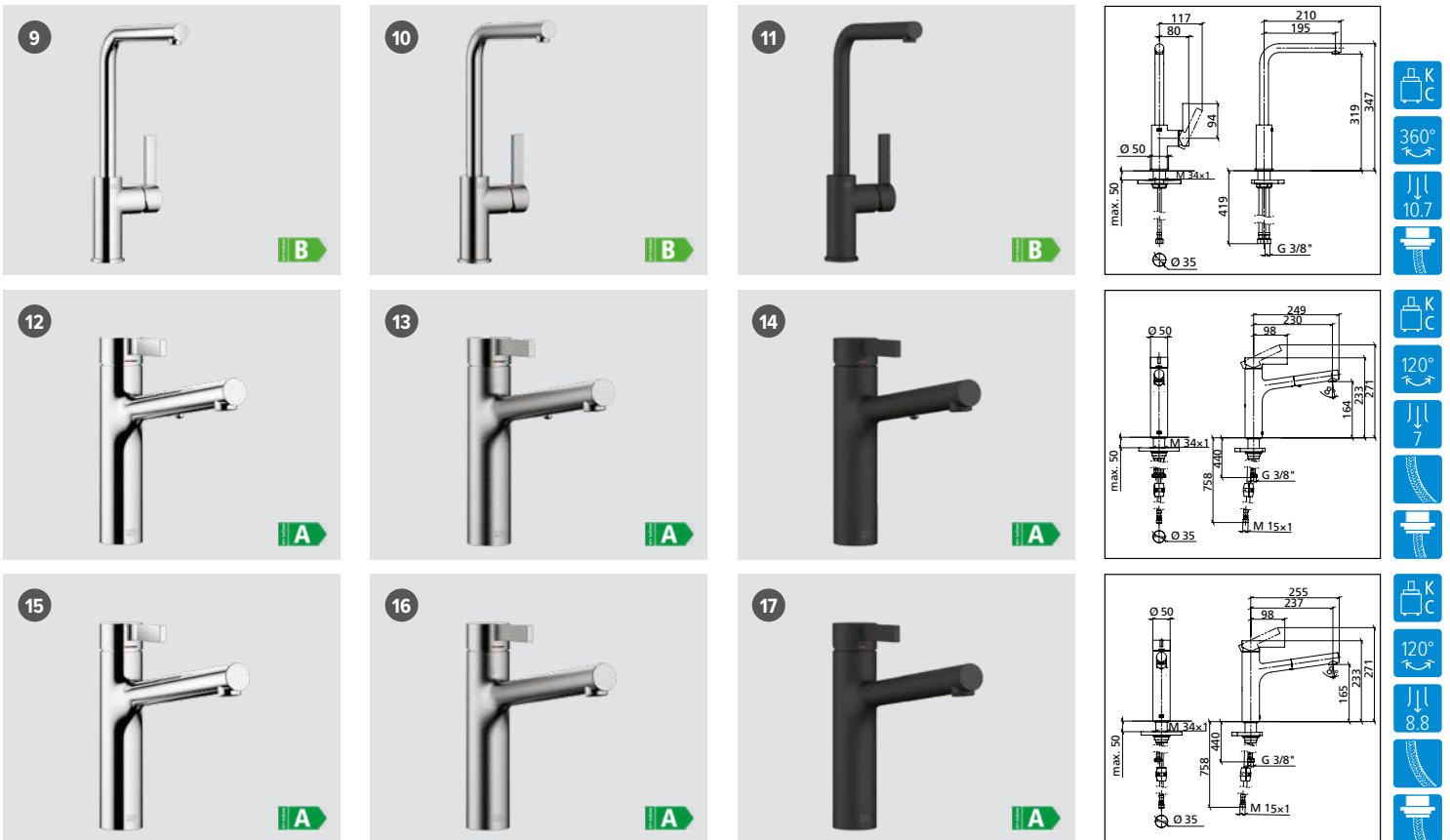

**i** Passende Dispenser und Zugknöpfe in allen Oberflächen auf den Seiten 363–369.  
Dispenser e pomoli abbinabili a tutte le superfici alle pagine 363–369.

Preis CHF/Prezzo in CHF

Name Nome	Modell Modello	Version/Oberfläche Versione/Superficie	Artikel-Nr. N. di articolo	Exkl. MWST IVA esclusa	Inkl. MWST IVA inclusa	
9	Koya	Side lever L/Chrom Side lever L/Cromato	40.002.469.00 L H	308.–	333.–	
10		Side lever L/Edelstahl-Finish Side lever L/Acciaio inox-finish	40.002.470.00 L H	391.–	423.–	
11		Side lever L/Pulverbeschichtung schwarz, matt Side lever L/Rivestimento con polvere nero, opaco	40.002.471.00 L H	391.–	423.–	
12	Koya	Top lever/Chrom Top lever/Cromato	40.002.481.00 L H	480.–	519.–	
13		Auszugsbrause Doccia estraibile ☆	Top lever/Edelstahl-Finish Top lever/Acciaio inox-finish	40.002.482.00 L H	567.–	613.–
14		Top lever/Pulverbeschichtung schwarz, matt Top lever/Rivestimento con polvere nero, opaco	40.002.483.00 L H	567.–	613.–	
15	Koya	Top lever/Chrom Top lever/Cromato	40.002.478.00 L H	391.–	423.–	
16		Zugauslauf Boccaglio estraibile ☆	Top lever/Edelstahl-Finish Top lever/Acciaio inox-finish	40.002.479.00 L H	499.–	539.–
17		Top lever/Pulverbeschichtung schwarz, matt Top lever/Rivestimento con polvere nero, opaco	40.002.480.00 L H	499.–	539.–	

☆ Mit Nylonschlauch / Con flessibile in nylon

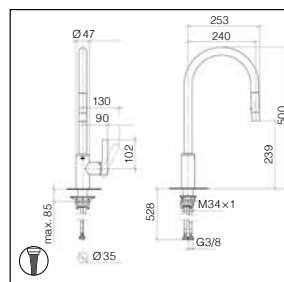
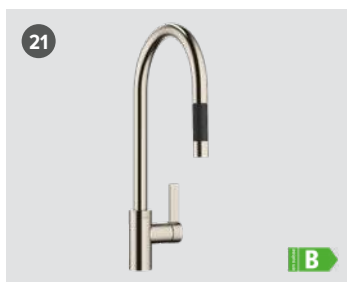
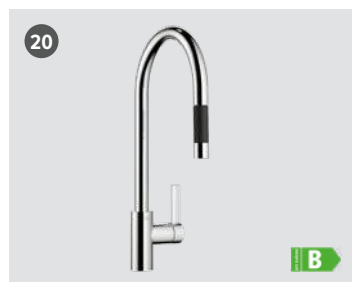
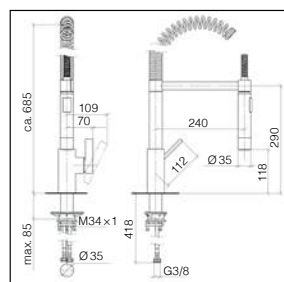
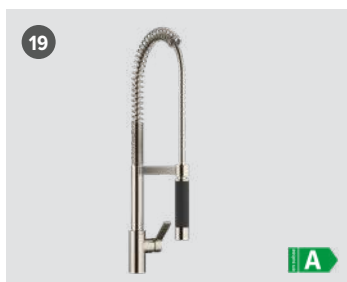
DORN  
BRACHT

Preis CHF/Prezzo in CHF

Name Nome	Modell Modello	Version/Oberfläche Versione/Superficie	Dornbracht-Nr. N. di Dornbracht	Artikel-Nr. N. di articolo	Inkl. MWST IVA inclusa	Inkl. MWST Incl. TVA
18	Tara Ultra Profibrausengarnitur Doccia professionale	Chrom Cromato	33860875-00	40.001.416.00 L H	1414.-	1529.-
19		Platin, matt Platino, opaco	33860875-06	40.001.417.00 L H	2263.-	2446.-
20	Tara Ultra Auszugsbrause Doccia estraibile	Chrom Cromato	33870875-00	40.001.666.00 L H	806.-	871.-
21		Platin, matt Platino, opaco	33870875-06	40.001.667.00 L H	1291.-	1396.-

\* Mit Metallschlauch / Con flessibile in metallo ⓘ Mit Laminarstrahl / Con getto laminare





**Oberflächen**  
Superfici



**Chrom**  
Cromato



**Ice**  
Ice

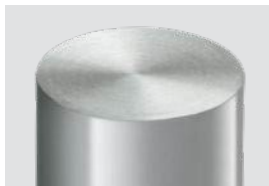

**Edelstahl**  
Acciaio inox



**Platin, matt**  
Platino, opaco

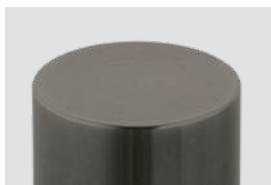

**PVD-Beschichtung, Graphit**  
Rivestimento a PVD, grafite



**PVD-Beschichtung, Inox Black**  
Rivestimento a PVD, Inox Black



**Pulverbeschichtung schwarz, matt**  
Rivestimento con polvere nero, opaco



**Nasslackierung schwarz, seidenglanz**  
Verniciatura all'acqua, satinato lucido

**Dispenser / Distributori**

Style	<b>364</b>
Epoc	<b>364</b>
Little Joe	<b>364</b>
Pinocchio	<b>364</b>
Tarzan	<b>365</b>
Nano	<b>365</b>
Merano	<b>366</b>
Dornbracht	<b>366</b>

**Zug-, Dreh- und Druckknöpfe**

**Pomoli / Pomoli girevoli / Pulsanti**

Pinocchio	<b>367</b>
Advant	<b>368</b>
Prime	<b>368</b>
Dornbracht	<b>368</b>
Druckknöpfe	
Pulsanti	<b>369</b>
Zugkabel	
Tirnaté	<b>369</b>



Alle unsere Dispenser-Modelle können durch einfaches Abheben des Oberteils bequem nachgefüllt werden.  
Tutti i nostri modelli di distributori di sapone si riempiono con facilità semplicemente sollevando la loro parte superiore.

## Dispenser / Distributori

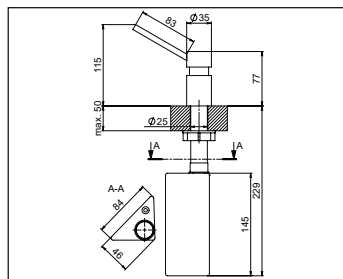
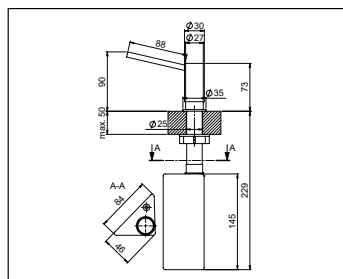
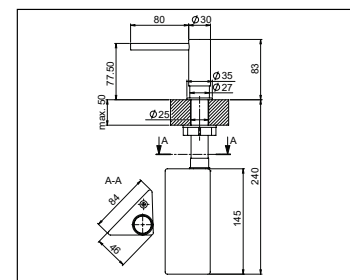
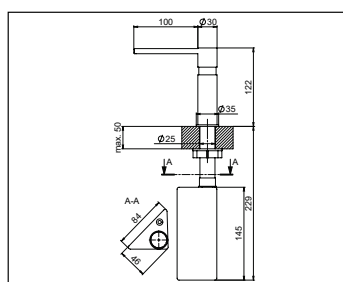

**i** **Dispenser-Bohrung, D = ø 25 mm, für alle Modelle**  
Distributori: foro D = ø 25 mm per tutti i modelli

**Preis CHF / Prezzo in CHF**

Name Nome	Beschreibung Descrizione	Material / Oberfläche Materiale / Superficie	Artikel-Nr. N. di articolo	Exkl. MWST IVA esclusa	Inkl. MWST IVA inclusa
<b>1</b> <b>Style*</b>	Auslauf 100 mm, Sockel D = ø 30 mm, mit Rosette D = ø 35 mm	Messing, verchromt Ottone, cromato	40.000.927.00 <b>L</b>	G 212.-	229.-
<b>2</b>	Bocca 100 mm, zoccolo D = ø 30 mm, con rosetta D = ø 35 mm	Edelstahl Acciaio inox	40.000.929.00 <b>L</b>	G 336.-	363.-
<b>3</b>	Auslauf 80 mm, Sockel D = ø 27 mm, mit Rosette D = ø 35 mm	Messing, verchromt Ottone, cromato	40.001.642.00 <b>L</b>	G 204.-	221.-
<b>4</b> <b>Epoc</b>	Bocca 80 mm, zoccolo D = ø 27 mm, con rosetta D = ø 35 mm	Edelstahl Acciaio inox	40.001.643.00 <b>L</b>	G 322.-	348.-
<b>5</b>		PVD-Beschichtung, Inox Black Rivestimento a PVD, Inox Black	40.002.526.00 <b>L</b>	G 445.-	481.-
<b>6</b> <b>Little Joe</b>	Auslauf 88 mm, Sockel D = ø 27 mm, mit Rosette D = ø 35 mm	Messing, verchromt Ottone, cromato	40.001.131.00 <b>L</b>	G 192.-	208.-
<b>7</b>	Bocca 88 mm, zoccolo D = ø 27 mm, con rosetta D = ø 35 mm	Edelstahl Acciaio inox	40.001.132.00 <b>L</b>	G 311.-	336.-
<b>8</b> <b>Pinocchio</b>	Auslauf 83 mm, Sockel D = ø 35 mm, ohne Rosette	Messing, verchromt Ottone, cromato	40.000.923.00 <b>L</b>	G 232.-	251.-
<b>9</b>	Bocca 83 mm, zoccolo D = ø 35 mm, senza rosetta	Edelstahl Acciaio inox	40.000.925.00 <b>L</b>	G 385.-	416.-
Dispenser-Bohrung, D = ø 25 mm, für alle Modelle Distributori: foro D = ø 25 mm per tutti i modelli			40.000.188.00	D 87.-	94.-

\* Kann mit oder ohne Rosette montiert werden / \* Può essere montato con o senza rosetta Alle Preise verstehen sich exkl. Einbau des Dispensers! / Tutti i prezzi devono intendersi montaggio escluso.

Dispenser / Distributori

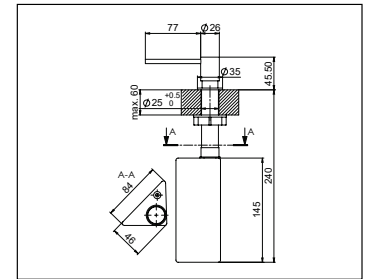
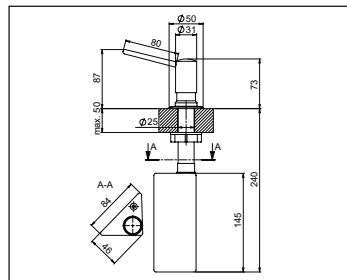

Preis CHF / Prezzo in CHF

Name Nome	Beschreibung Descrizione	Material / Oberfläche Materiale / Superficie	Artikel-Nr. N. di articolo	Exkl. MWST IVA esclusa	Inkl. MWST IVA inclusa
10 <b>Tarzan</b>	Auslauf 80 mm, Sockel D = ø 31 mm, mit Rosette D = ø 50 mm Bocca 80 mm, zoccolo D = ø 31 mm, con rosetta D = ø 50 mm	Messing, verchromt Ottone, cromato	40.000.176.00 <b>L</b> G	157.–	170.–
11	Auslauf 77 mm, Sockel D = ø 35 mm Bocca 77 mm, zoccolo D = ø 35 mm	Messing, verchromt Ottone, cromato	40.001.314.00 <b>L</b> G	155.–	168.–
12		Edelstahl Acciaio inox	40.001.313.00 <b>L</b> G	291.–	315.–
13		PVD-Beschichtung, Graphit Acciaio inox, con rivestimento a PVD, grafite	40.001.543.00 <b>L</b> G	383.–	414.–
14 <b>Nano</b>		PVD-Beschichtung, Inox Black Rivestimento a PVD, Inox Black	40.002.527.00 <b>L</b> G	383.–	414.–
15		Pulverbeschichtung schwarz, matt Rivestimento con polvere nero, opaco	40.002.155.00 <b>L</b> G	361.–	390.–
16		Nasslackierung schwarz, seidenglanz Verniciatura all'acqua, color nero satinato lucido	40.002.355.00 <b>L</b> G	361.–	390.–
Dispenser-Bohrung, D = ø 25 mm, für alle Modelle Distributori: foro D = ø 25 mm per tutti i modelli			40.000.188.00 D	87.–	94.–

Alle Preise verstehen sich exkl. Einbau des Dispensers! / Tutti i prezzi devono intendersi montaggio escluso.

## Dispenser / Distributori

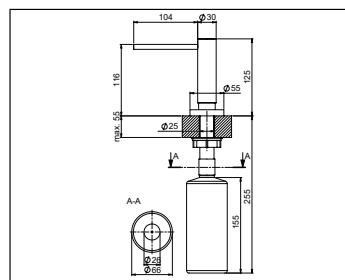
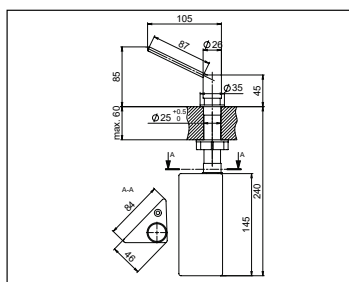

**i** **Dispenser-Bohrung, D = ø 25 mm, für alle Modelle (Toleranz für Nano, Merano siehe Zeichnungen)**  
 Distributori: foro D = ø 25 mm per tutti i modelli (tolleranze per Nano, Merano come da disegni)

**Preis CHF/Prezzo in CHF**

Name Nome	Beschreibung Descrizione	Material/Oberfläche Materiale/Superficie	Artikel-Nr. N. di articolo	Exkl. MWST IVA esclusa	Inkl. MWST IVA inclusa
17 <b>Merano</b>	Auslauf 87 mm, Sockel D = ø 35 mm Bocca 87 mm, zoccolo D = ø 35 mm	Edelstahl Acciaio inox	40.001.434.00 <b>L</b> G	330.–	357.–
18 <b>Dornbracht</b>	Auslauf 104 mm, Sockel D = ø 30 mm, mit Rosette D = ø 55 mm	Messing, verchromt Ottone, cromato	40.001.424.00 <b>L</b> H	267.–	289.–
19 <b>Dornbracht</b>	Bocca 104 mm, zoccolo D = ø 30 mm, con rosetta D = ø 55 mm	Platin, matt Platino, opaco	40.001.425.00 <b>L</b> H	427.–	462.–
Dispenser-Bohrung, D = ø 25 mm, für alle Modelle Distributori: foro D = ø 25 mm per tutti i modelli			40.000.188.00 D	87.–	94.–

Alle Preise verstehen sich exkl. Einbau des Dispensers! / Tutti i prezzi devono intendersi montaggio escluso.

# Zug-, Dreh- und Druckknöpfe

## Pomoli / Pomoli girevoli / Pulsanti



**!** Varianten: Der Austausch von Zugknöpfen erfolgt mittels Variantencode. Mehr Infos siehe Seite 395.  
 Varianti: La sostituzione di pomoli avviene mediante codice variante. Per maggiori informazioni, vedere pag. 395.

**Preis CHF / Prezzo in CHF**

Name Nome	Beschreibung Descrizione	Material/ Oberfläche Materiale/Superficie	Artikel-Nr. N. di articolo	Exkl. MWST IVA esclusa	Inkl. MWST IVA inclusa	Artikel-Nr. N. di articolo	Exkl. MWST IVA esclusa	Inkl. MWST IVA inclusa	
Austausch Zugknopf ** / Sostituzione del pomolo **									
<b>1</b>	<b>Pinocchio*</b> Zugknopf, komplett, massiv Metall, mit Rosette D = ø 25 mm Pomolo, completo, metallo massiccio, con rosetta D = ø 25 mm	Messing, verchromt Ottone, cromato	40.000.931.00	F	54.–	58.–	40.000.931.01	30.–	32.–
<b>2</b>		Ice	40.001.580.00	F	132.–	143.–	40.001.580.01	108.–	117.–
<b>3</b>		Edelstahl Acciaio inox	40.000.933.00	F	107.–	116.–	40.000.933.01	83.–	90.–
<b>4</b>		Platin, matt Platino, opaco	40.001.454.00	F	132.–	143.–	40.001.454.01	108.–	117.–
<b>5</b>		PVD-Beschichtung, Graphit Rivestimento a PVD, grafite	40.001.283.00	F	132.–	143.–	40.001.283.01	108.–	117.–
<b>6</b>		PVD-Beschichtung, Inox Black Rivestimento a PVD, Inox Black	40.002.528.00	F	132.–	143.–	40.002.528.01	108.–	117.–
<b>7</b>		Pulverbeschichtung schwarz, matt Rivestimento con polvere nero, opaco	40.002.156.00	F	125.–	135.–	40.002.156.01	101.–	109.–
<b>8</b>		Nasslackierung schwarz, seidenglanz Verniciatura all'acqua, color nero satinato lucido	40.002.356.00	F	125.–	135.–	40.002.356.01	101.–	109.–

\* Kann mit oder ohne Rosette montiert werden / Può essere montato con o senza rosetta

\*\* Nur in Verbindung mit ausgewählten Spülen und Becken erhältlich / Solo in abbinamento a lavelli e lavabi selezionati

## Zug-, Dreh- und Druckknöpfe

### Pomoli / Pomoli girevoli / Pulsanti

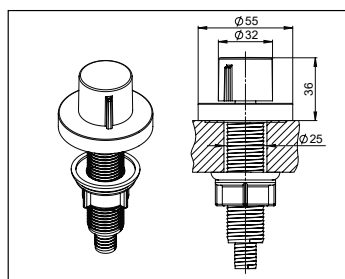
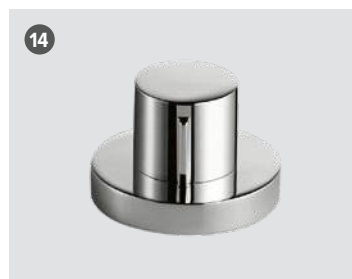
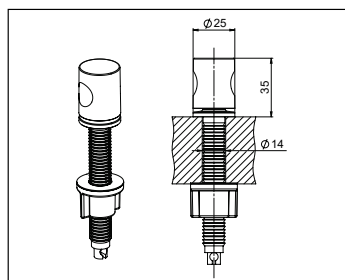
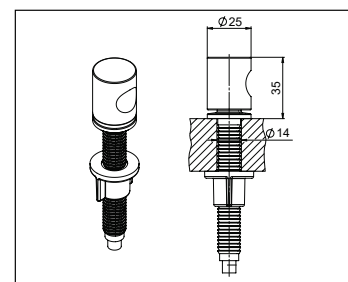

**!** Varianten: Der Austausch von Zugknöpfen erfolgt mittels Variantencode. Mehr Infos siehe Seite 395.  
Varianti: La sostituzione di pomoli avviene mediante codice variante. Per maggiori informazioni, vedere pag. 395.

**i** **Zugknopf-Bohrung für Pinocchio, Advant, Prime, D = ø 14 mm**  
Pomolo: foro per Pinocchio, Advant, Prime, D = ø 14 mm

**Drehknopf-Bohrung für Dornbracht, D = ø 25 mm**  
Pomolo girevole: foro per Dornbracht, D = ø 25 mm

Preis CHF / Prezzo in CHF

Name Nome	Beschreibung Descrizione	Material/ Oberfläche Materiale/Superficie	Artikel-Nr. N. di articolo	Exkl. MWST IVA esclusa	Inkl. MWST IVA inclusa	Artikel-Nr. N. di articolo	Exkl. MWST IVA esclusa	Inkl. MWST IVA inclusa	
9	Zugknopf, komplett, massiv Metall, mit Sockel D = ø 25 mm Pomolo, completo, metallo massiccio, con zoccolo D = ø 25 mm	Messing, verchromt Ottone, cromato	40.000.935.00	F	27.–	29.–	40.000.935.01	3.–	4.–
10		Edelstahl Acciaio inox	40.002.546.00	F	56.–	61.–	40.002.546.01	32.–	35.–
11		Pulverbeschichtung schwarz, matt Rivestimento con polvere nero, opaco	40.002.766.00	F	74.–	80.–	40.002.766.01	50.–	54.–
12	Zugknopf, komplett, Kunststoff, mit Sockel D = ø 25 mm Pomolo, completo, plastica, con zoccolo D = ø 25 mm	ABS-Kunststoff, verchromt ABS, cromato	40.001.006.00	F	22.–	24.–			
13		ABS-Kunststoff, schwarz, matt ABS, nero, opaco	40.002.765.00	F	24.–	26.–	40.002.765.01	0.–	0.–
14	Drehknopf-Garnitur, komplett, mit Rosette D = ø 55 mm Pomolo girevole, completo, con rosetta D = ø 55 mm	Messing, verchromt Ottone, cromato	40.001.422.00	H	173.–	187.–	40.001.422.01	149.–	161.–
15		Platin, matt Platino, opaco	40.001.423.00	H	276.–	298.–	40.001.423.01	252.–	272.–

\* Nicht kompatibel mit Raumspar Desino / Non compatibile con salvaspazio Desino

\*\* Nur in Verbindung mit ausgewählten Spülen und Becken erhältlich / Solo in abbinamento a lavelli e lavabi selezionati

# Zug-, Dreh- und Druckknöpfe

## Pomoli / Pomoli girevoli / Pulsanti

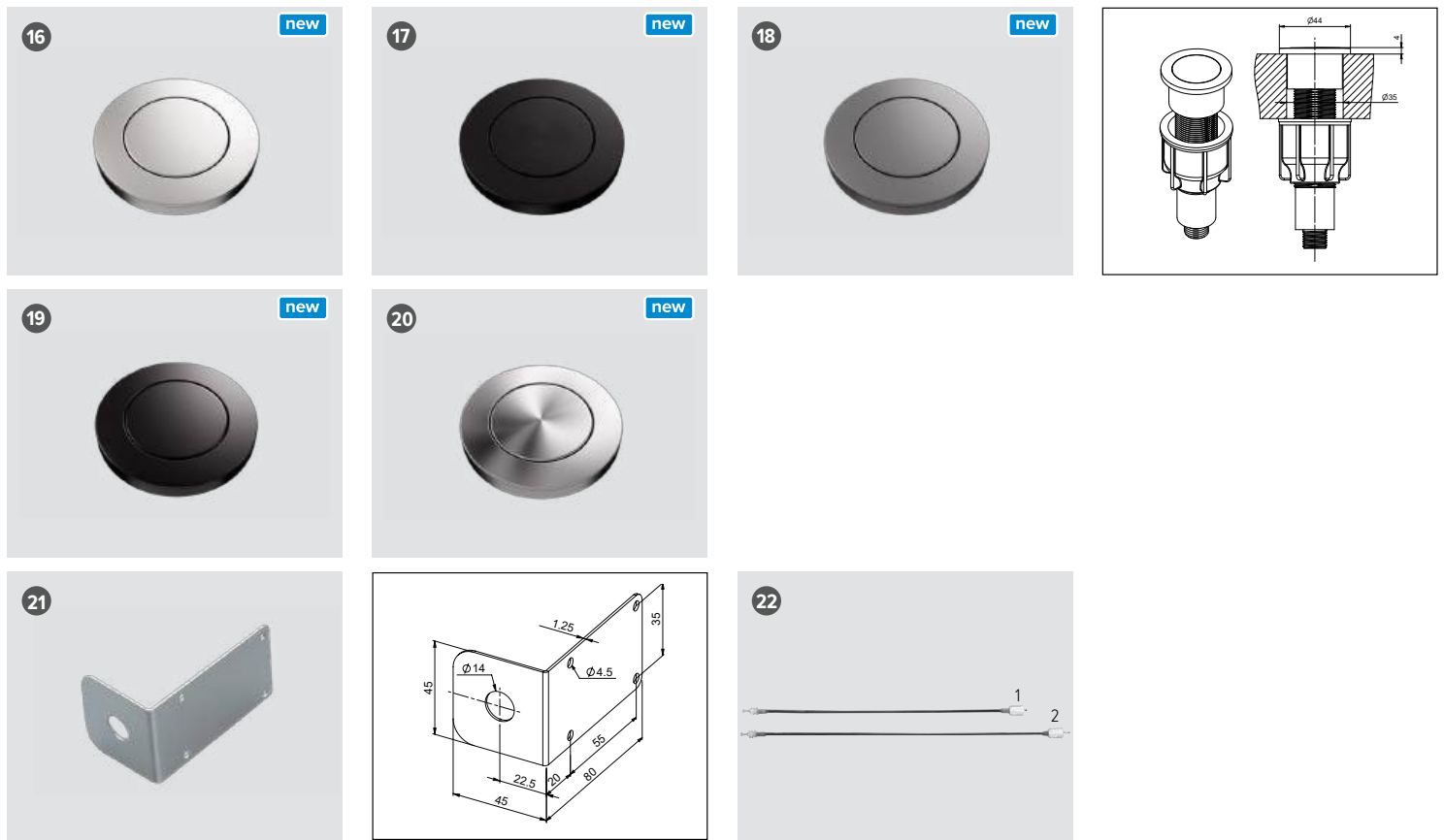

**i** **Druckknopf-Bohrung, D = ø 35 mm, Wahl zwischen flächenbündig oder aufliegendem Einbau. Mehr Infos siehe suter.ch**  
 Pulsante foro D = ø 35 mm, possibilità di montaggio a filo top o sopra piano. Maggiori informazioni sono disponibili su suter.ch.

Preis CHF / Prezzo in CHF

Name Nome	Beschreibung Descrizione	Material / Oberfläche Materiale / Superficie	Artikel-Nr. <b>L</b> N. di articolo	Exkl. MWST IVA esclusa	Inkl. MWST IVA inclusa	Artikel-Nr. <b>L</b> N. di articolo	Exkl. MWST IVA esclusa	Inkl. MWST IVA inclusa	
Austausch Druckknopf ** / Sostituzione del pulsante **									
16	<b>Druckknopf</b> */ **/ ****  Druckknopf, komplett, D = ø 44 mm Pulsante, completo D = ø 44 mm	Edelstahl, massiv Acciaio inox, massiccio	40.003.081.00	F	126.–	136.–	40.003.081.01	81.–	88.–
17		Pulverbeschichtet schwarz, matt Rivestimento con polvere nero, opaco	40.003.082.00	F	142.–	154.–	40.003.082.01	97.–	105.–
18		PVD-Beschichtung Graphit Rivestimento a PVD, grafite	40.003.083.00	F	154.–	166.–	40.003.083.01	109.–	118.–
19		PVD-Beschichtung Inox Black Rivestimento a PVD, Inox Black	40.003.084.00	F	154.–	166.–	40.003.084.01	109.–	118.–
20		Chrom Cromato	40.003.085.00	F	69.–	75.–			
21	Unterschrank-Montagewinkel für Zugknopf Staffa angolare di montaggio per base del pomolo	Edelstahl Acciaio inox	40.001.469.00	F	32.–	35.–			
22	1 Zugkabel, Länge 635 mm, komplett Tirante, lungh. 635 mm, completo	PE-POM-18/10, schwarz PE-POM-18/10, nero	40.000.152.00	F	34.–	37.–			
	2 Zugkabel, Länge 1000 mm, komplett Tirante, lungh. 1000 mm, completo		40.000.383.00	F	45.–	49.–			

\* Nicht kompatibel mit Brooklyn Becken / Montaggio incompatibile con il lavello Brooklyn \*\*\* Nicht kompatibel mit Raumspare Desino / Non compatibile con salvaspazio Desino

\*\* Nur in Verbindung mit ausgewählten Spülen und Becken erhältlich / Solo in abbinamento a lavelli e lavabi selezionati \*\*\*\* Nicht kompatibel mit Unterschrank-Montagewinkel / Non compatibile con staffa di montaggio per base



**Abfall-Systeme****Sistemi di raccolta rifiuti**

Müllex D-Line **372**

Müllex X-Line: Set-Angebote mit  
Zargenführungssystem

Müllex X-Line: Offerte di set con  
sistema di guida del telaio **374**

Müllex X-Line: Speziallösungen für  
Wasseraufbereitungssysteme

Müllex X-Line: Soluzioni speciali per  
sistemi di trattamento dell'acqua **378**

Müllex X-Line: Set-Angebote für  
bestehende Schubladenauszüge

Müllex X-Line: Offerta di set per  
guide cassette esistenti **379**

Müllex X-Line: Einzelkomponenten

Müllex X-Line: Componenti singoli **383**

Müllex BOXX **387**

Müllex Heavy Bag **388**

**Masszeichnungen**

**Disegni tecnici 389**

## Müllex D-Line / Müllex D-Line

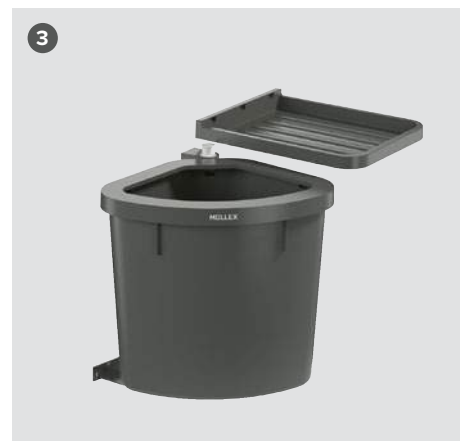
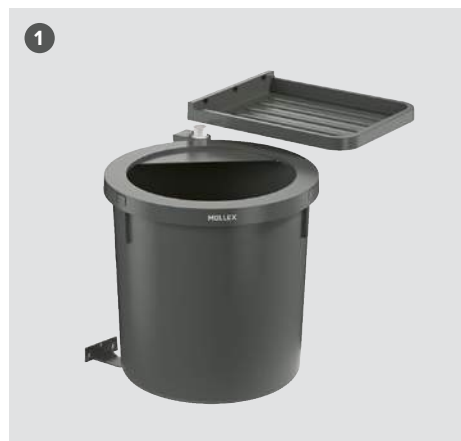

## Preis CHF/Prezzo in CHF

Modell Modello	Beschreibung Descrizione	Müllex-Nr. N. di Müllex	Artikel-Nr. N. di articolo	Exkl. MWST IVA esclusa	Inkl. MWST IVA inclusa
1 <b>D50 L1, Einbauhöhe L, 440 mm Altezza d'ingombro L, 440 mm</b>	System für Drehtüren / ab 500 mm Korpusbreite / 35 oder 17 Liter Abfallsäcke / praktischer Ablagedeckel / Volumen 35 Liter Sistema per porte a battente / corpo a partire da 500 mm / per sacchi da 35 o 17 litri / pratico coperchio di contenimento / volume 35 litri	80.71.101	40.002.646.00 L G	106.–	115.–
2 <b>D50 M1, Einbauhöhe M, 390 mm Altezza d'ingombro M, 390 mm</b>	Niedriges System für Drehtüren / ab 500 mm Korpusbreite / 35 oder 17 Liter Abfallsäcke / praktischer Ablagedeckel / Volumen 30 Liter Sistema basso per porte a battente / corpo a partire da 500 mm / per sacchi da 35 o 17 litri / pratico coperchio di contenimento / volume 30 litri	80.71.102	40.002.647.00 L G	106.–	115.–
3 <b>D40 L3, Einbauhöhe L, 440 mm Altezza d'ingombro L, 440 mm</b>	System für Drehtüren / ab 400 mm Korpusbreite / 35 oder 17 Liter Abfallsäcke / praktischer Ablagedeckel / Volumen 25 Liter Sistema per porte a battente / corpo a partire da 400 mm / per sacchi da 35 o 17 litri / pratico coperchio di contenimento / volume 25 litri	80.71.001	40.002.648.00 L G	96.–	104.–
4 <b>D40 M3, Einbauhöhe M, 390 mm Altezza d'ingombro M, 390 mm</b>	Niedriges System für Drehtüren / ab 400 mm Korpusbreite / 35 oder 17 Liter Abfallsäcke / praktischer Ablagedeckel / Volumen 21 Liter Sistema basso per porte a battente / corpo a partire da 400 mm / per sacchi da 35 o 17 litri / pratico coperchio di contenimento / volume 21 litri	80.71.002	40.002.649.00 L G	96.–	104.–

## Müllex D-Line / Müllex D-Line



Preis CHF / Prezzo in CHF

Modell Modello	Beschreibung Descrizione	Müllex-Nr. N. di Müllex	Artikel-Nr. N. di articolo	Exkl. MWST IVA esclusa	Inkl. MWST IVA inclusa
5 <b>Trennsteg D1 Separatore D1</b>	Der Trennsteg D1 ist speziell für D50 Drehtürsysteme ausgelegt / unterteilt den Hauptbehälter so, dass zwei 17 Liter Abfallsäcke eingespannt werden können Il divisorio D1 è stato progettato appositamente per i sistemi a porte girevoli D50 / divide il contenitore principale in modo da poter bloccare due sacchi di rifiuti da 17 litri	12970	40.002.650.00	19.–	21.–
6 <b>Trennsteg D3 Separatore D3</b>	Der Trennsteg D3 ist speziell für D40 Drehtürsysteme ausgelegt / unterteilt den Hauptbehälter so, dass zwei 17 Liter Abfallsäcke eingespannt werden können Il separatore D3 è stato progettato appositamente per i sistemi a porte girevoli D40 / divide il contenitore principale in modo da poter bloccare due sacchi di rifiuti da 17 litri	12977	40.002.651.00	19.–	21.–

## Müllex X-Line: Set-Angebote mit Zargenführungssystem

### Müllex X-Line: Offerte di set con sistema di guida del telaio



Preis CHF / Prezzo in CHF

Modell Modello	Set bestehend aus Set costituito da	Müllex-Nr. N. di Müllex	Artikel-Nr. N. di articolo	Exkl. MWST IVA esclusa	Inkl. MWST IVA inclusa
<b>1</b> X45 L35 Basic Pro, Einbauhöhe L, 446 mm Altezza d'ingombro L, 446 mm	Schublade Basic 450 mm 80.41.101+ Abfalltrennbehälter X45 L35 80.51.101+ Komplettschubkasten 45 Pro 80.61.101, Korpusbreite 450 mm Cassetto Basic 450 mm 80.41.101+ Contentitore per separazione rifiuti X45 L35 80.51.101+ Cassetto completo 45 Pro 80.61.101, larghezza modulo 450 mm	80.60.101	40.002.902.00 <b>L</b> G	328.–	355.–
<b>2</b> X45 M35 Basic Pro, Einbauhöhe M, 399 mm Altezza d'ingombro M, 399 mm	Schublade Basic 450 mm 80.41.101+ Abfalltrennbehälter X45 M35 80.51.102 Komplettschubkasten 45 Pro 80.61.101, Korpusbreite 450 mm Cassetto Basic 450 mm 80.41.101+ Contentitore per separazione rifiuti X45 M35 80.51.102+ Cassetto completo 45 Pro 80.61.101, larghezza modulo 450 mm	80.60.103	40.002.903.00 <b>L</b> G	328.–	355.–
<b>2</b> X50 L35 Basic Pro, Einbauhöhe L, 446 mm Altezza d'ingombro L, 446 mm	Schublade Basic 500 mm 80.41.201+ Abfalltrennbehälter X45 L35, 80.51.101 Komplettschubkasten 50 Pro 80.61.201, Korpusbreite 500 mm Cassetto Basic 500 mm 80.41.201+ Contentitore per separazione rifiuti X45 L35, 80.51.101+ Cassetto completo 50 Pro 80.61.201, larghezza modulo 500 mm	80.60.201	40.002.904.00 <b>L</b> G	328.–	355.–
<b>2</b> X50 M35 Basic Pro, Einbauhöhe M, 399 mm Altezza d'ingombro M, 399 mm	Schublade Basic 500 mm 80.41.201+ Abfalltrennbehälter X45 M35 80.51.102 Komplettschubkasten 50 Pro 80.61.201, Korpusbreite 500 mm Cassetto Basic 500 mm 80.41.201+ Contentitore per separazione rifiuti X45 M35 80.51.102+ Cassetto completo 50 Pro 80.61.201, larghezza modulo 500 mm	80.60.203	40.002.905.00 <b>L</b> G	328.–	355.–
<b>3</b> X55 L7 Basic Pro, Einbauhöhe L, 446 mm Altezza d'ingombro L, 446 mm	Schublade Basic 550 mm 80.41.301+ Abfalltrennbehälter X55 L7 80.51.303 Komplettschubkasten 55 Pro 80.61.301, Korpusbreite 550 mm Cassetto Basic 550 mm 80.41.301+ Contentitore per separazione rifiuti X55 L7 80.51.303+ Cassetto completo 55 Pro 80.61.301, larghezza modulo 550 mm	80.60.305	40.002.906.00 <b>L</b> G	368.–	398.–
<b>3</b> X55 M7 Basic Pro, Einbauhöhe M, 399 mm Altezza d'ingombro M, 399 mm	Schublade Basic 550 mm 80.41.301+ Abfalltrennbehälter X55 M7 80.51.304 Komplettschubkasten 55 Pro 80.61.301, Korpusbreite 550 mm Cassetto Basic 550 mm 80.41.301+ Contentitore per separazione rifiuti X55 M7 80.51.304+ Cassetto completo 55 Pro 80.61.301, larghezza modulo 550 mm	80.60.307	40.002.907.00 <b>L</b> G	368.–	398.–

## Müllex X-Line: Set-Angebote mit Zargenführungssystem

### Müllex X-Line: Offerte di set con sistema di guida del telaio



#### Preis CHF / Prezzo in CHF

Modell Modello	Set bestehend aus Set costituito da	Müllex-Nr. N. di Müllex	Artikel-Nr. N. di articolo	Exkl. MWST IVA esclusa	Inkl. MWST IVA inclusa
<b>4</b> X55 L5 Basic Pro, Einbauhöhe L, 446 mm Altezza d'ingombro L, 446 mm	Schublade Basic 550 mm 80.41.301+ Abfalltrennbehälter X55 L5 80.51.301+ Komplettschubkasten 55 Pro 80.61.301, Korpusbreite 550 mm Cassetto Basic 550 mm 80.41.301+ Contentitore per separazione rifiuti X55 L5 80.51.301+ Cassetto completo 55 Pro 80.61.301, larghezza modulo 550 mm	80.60.301	40.002.908.00 <b>L</b> G	397.–	429.–
<b>5</b> X55 M5 Basic Pro, Einbauhöhe M, 399 mm Altezza d'ingombro M, 399 mm	Schublade Basic 550 mm 80.41.301+ Abfalltrennbehälter X55 M5 80.51.302+ Komplettschubkasten 55 Pro 80.61.301, Korpusbreite 550 mm Cassetto Basic 550 mm 80.41.301+ Contentitore per separazione rifiuti X55 M5 80.51.302+ Cassetto completo 55 Pro 80.61.301, larghezza modulo 550 mm	80.60.303	40.002.909.00 <b>L</b> G	397.–	429.–
<b>5</b> X60 L7 Basic Pro, Einbauhöhe L, 446 mm Altezza d'ingombro L, 446 mm	Schublade Basic 600 mm 80.41.401+ Abfalltrennbehälter X60 L7 80.51.403+ Komplettschubkasten 60 Pro 80.61.401, Korpusbreite 600 mm Cassetto Basic 600 mm 80.41.401+ Contentitore per separazione rifiuti X60 L7 80.51.403+ Cassetto completo 60 Pro 80.61.401, larghezza modulo 600 mm	80.60.405	40.002.910.00 <b>L</b> G	368.–	398.–
<b>5</b> X60 M7 Basic Pro, Einbauhöhe M, 399 mm Altezza d'ingombro M, 399 mm	Schublade Basic 600 mm 80.41.401+ Abfalltrennbehälter X60 M7 80.51.404+ Komplettschubkasten 60 Pro 80.61.401, Korpusbreite 600 mm Cassetto Basic 600 mm 80.41.401+ Contentitore per separazione rifiuti X60 M7 80.51.404+ Cassetto completo 60 Pro 80.61.401, larghezza modulo 600 mm	80.60.389	40.002.911.00 <b>L</b> G	368.–	398.–
<b>6</b> X60 L5 Basic Pro, Einbauhöhe L, 446 mm Altezza d'ingombro L, 446 mm	Schublade Basic 600 mm 80.41.401+ Abfalltrennbehälter X60 L5 80.51.401+ Komplettschubkasten 60 Pro 80.61.401, Korpusbreite 600 mm Cassetto Basic 600 mm 80.41.401+ Contentitore per separazione rifiuti X60 L5 80.51.401+ Cassetto completo 60 Pro 80.61.401, larghezza modulo 600 mm	80.60.401	40.002.912.00 <b>L</b> G	397.–	429.–
<b>6</b> X60 M5 Basic Pro, Einbauhöhe M, 399 mm Altezza d'ingombro M, 399 mm	Schublade Basic 600 mm 80.41.401+ Abfalltrennbehälter X60 M5 80.51.402+ Komplettschubkasten 60 Pro 80.61.401, Korpusbreite 600 mm Cassetto Basic 600 mm 80.41.401+ Contentitore per separazione rifiuti X60 M5 80.51.402+ Cassetto completo 60 Pro 80.61.401, larghezza modulo 600 mm	80.60.403	40.002.913.00 <b>L</b> G	397.–	429.–

## Müllex X-Line: Set-Angebote mit Zargenführungssystem

### Müllex X-Line: Offerte di set con sistema di guida del telaio



Preis CHF / Prezzo in CHF

Modell Modello	Set bestehend aus Set costituito da	Müllex-Nr. N. di Müllex	Artikel-Nr. N. di articolo	Exkl. MWST IVA esclusa	Inkl. MWST IVA inclusa
<b>7</b> <b>X55 L7 Premium Pro,</b> <b>Einbauhöhe L,</b> <b>446 mm</b> <b>Altezza d'ingombro L,</b> <b>446 mm</b>	Schublade Premium 550 mm 80.42.301+ Abfalltrennbehälter X55 L7 80.51.303+ Komplettschubkasten 55 Pro 80.61.301, Korpusbreite 550 mm Cassetto Premium 550 mm 80.42.301+ Contentitore per separazione rifiuti X55 L7 80.51.303+ Cassetto completo 55 Pro 80.61.301, larghezza modulo 550 mm	80.60.306	40.002.914.00 <b>L</b> G	414.–	448.–
<b>8</b> <b>X55 M7 Premium Pro,</b> <b>Einbauhöhe M,</b> <b>399 mm</b> <b>Altezza d'ingombro M,</b> <b>399 mm</b>	Schublade Premium 550 mm 80.42.301+ Abfalltrennbehälter X55 M7 80.51.304+ Komplettschubkasten 55 Pro 80.61.301, Korpusbreite 550 mm Cassetto Premium 550 mm 80.42.301+ Contentitore per separazione rifiuti X55 M7 80.51.304+ Cassetto completo 55 Pro 80.61.301, larghezza modulo 550 mm	80.60.308	40.002.915.00 <b>L</b> G	414.–	448.–
<b>8</b> <b>X55 L5 Premium Pro,</b> <b>Einbauhöhe L,</b> <b>446 mm</b> <b>Altezza d'ingombro L,</b> <b>446 mm</b>	Schublade Premium 550 mm 80.42.301+ Abfalltrennbehälter X55 L5 80.51.301+ Komplettschubkasten 55 Pro 80.61.301, Korpusbreite 550 mm Cassetto Premium 550 mm 80.42.301+ Contentitore per separazione rifiuti X55 L5 80.51.301+ Cassetto completo 55 Pro 80.61.301, larghezza modulo 550 mm	80.60.302	40.002.916.00 <b>L</b> G	443.–	479.–
<b>8</b> <b>X55 M5 Premium Pro,</b> <b>Einbauhöhe M,</b> <b>399 mm</b> <b>Altezza d'ingombro M,</b> <b>399 mm</b>	Schublade Premium 550 mm 80.42.301+ Abfalltrennbehälter X55 M5 80.51.302+ Komplettschubkasten 55 Pro 80.61.301, Korpusbreite 550 mm Cassetto Premium 550 mm 80.42.301+ Contentitore per separazione rifiuti X55 M5 80.51.302+ Cassetto completo 55 Pro 80.61.301, larghezza modulo 550 mm	80.60.304	40.002.917.00 <b>L</b> G	443.–	479.–
<b>9</b> <b>X60 L7 Premium Pro,</b> <b>Einbauhöhe L,</b> <b>446 mm</b> <b>Altezza d'ingombro L,</b> <b>446 mm</b>	Schublade Premium 600 mm 80.42.401+ Abfalltrennbehälter X60 L7 80.51.403+ Komplettschubkasten 60 Pro 80.61.401, Korpusbreite 600 mm Cassetto Premium 600 mm 80.42.401+ Contentitore per separazione rifiuti X60 L7 80.51.403+ Cassetto completo 60 Pro 80.61.401, larghezza modulo 600 mm	80.60.406	40.002.918.00 <b>L</b> G	414.–	448.–
<b>9</b> <b>X60 M7 Premium Pro,</b> <b>Einbauhöhe M,</b> <b>399 mm</b> <b>Altezza d'ingombro M,</b> <b>399 mm</b>	Schublade Premium 600 mm 80.42.401+ Abfalltrennbehälter X60 M7 80.51.404+ Komplettschubkasten 60 Pro 80.61.401, Korpusbreite 600 mm Cassetto Premium 600 mm 80.42.401+ Contentitore per separazione rifiuti X60 M7 80.51.404+ Cassetto completo 60 Pro 80.61.401, larghezza modulo 600 mm	80.60.390	40.002.919.00 <b>L</b> G	414.–	448.–

## Müllex X-Line: Set-Angebote mit Zargenführungssystem

Müllex X-Line: Offerte di set con sistema di guida del telaio



Preis CHF / Prezzo in CHF

Modell Modello	Set bestehend aus Set costituito da	Müllex-Nr. N. di Müllex	Artikel-Nr. N. di articolo	Exkl. MWST IVA esclusa	Inkl. MWST IVA inclusa
<b>X60 L5 Premium Pro, Einbauhöhe L, 446 mm Altezza d'ingombro L, 446 mm</b>	Schublade Premium 600 mm 80.42.401+ Abfalltrennbehälter X60 L5 80.51.401+ Komplettschubkasten 60 Pro 80.61.401, Korpusbreite 600 mm Cassetto Premium 600 mm 80.42.401+ Contentitore per separazione rifiuti X60 L5 80.51.401+ Cassetto completo 60 Pro 80.61.401, larghezza modulo 600 mm	80.60.402	40.002.920.00 <b>L</b> G	443.–	479.–
<b>X60 M5 Premium Pro, Einbauhöhe M, 399 mm Altezza d'ingombro M, 399 mm</b>	Schublade Premium 600 mm 80.42.401+ Abfalltrennbehälter X60 M5 80.51.402+ Komplettschubkasten 60 Pro 80.61.401, Korpusbreite 600 mm Cassetto Premium 600 mm 80.42.401+ Contentitore per separazione rifiuti X60 M5 80.51.402+ Cassetto completo 60 Pro 80.61.401, larghezza modulo 600 mm	80.60.404	40.002.921.00 <b>L</b> G	443.–	479.–

## Müllex X-Line: Speziallösungen für Wasseraufbereitungssysteme, Set-Angebote mit Zargenführungssystem / Müllex X-Line: Soluzioni speciali per sistemi di trattamento dell'acqua, offerte di set con sistema di guida del telaio

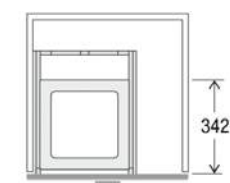

X	WS	S (max.)
600	16	208
	19	202
550	16	158
	19	152

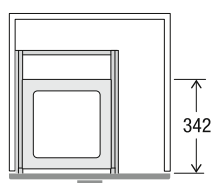

X	WS	S (max.)
600	16-19	212

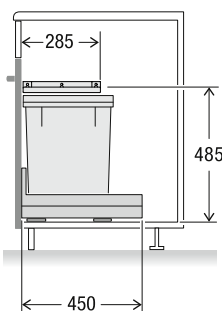
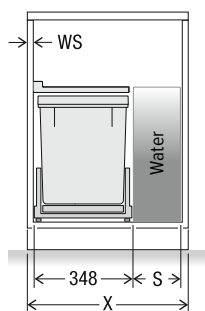
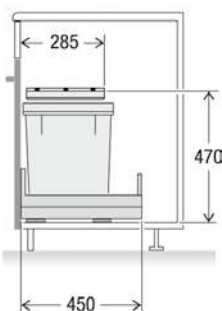
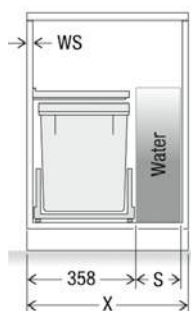

Varianten: Bei Inanspruchnahme des Montageservice von Laufen Schweiz für das System X40 L35 Vara bestellen **Sie bitte die Artikel-Nr. mit Endziffer .80 und zusätzlich den gewünschten Montageserviceartikel auf Seite 346 Bildhinweisnummer 5.**

Varianti: In caso di utilizzo del servizio di montaggio da parte di Laufen Svizzera per il sistema X40 L35 Vara, **si prega di ordinare gli articoli con cifra finale .80 e in aggiunta con l'articolo del servizio d'installazione desiderato a pagina 346 riferimento immagine numero 5.**

**Preis CHF / Prezzo in CHF**

Modell Modello	Set bestehend aus Set costituito da	Müllex-Nr. N. di Müllex	Artikel-Nr. N. di articolo	Exkl. MWST IVA esclusa	Inkl. MWST IVA inclusa
<b>11</b> X40 L35 Pro Water	Schmales Komplettsystem für Küchenunterschranke mit seitlich installierten Wasseraufbereitungslösungen. Die Montage kann rechts oder links erfolgen. 40 Liter Hauptbehälter, Ablagedeckel seitlich fix und Komplettschubkasten Pro. Korpusbreite 550/600 mm Systema completo compatto per mobili da cucina con soluzioni di trattamento dell'acqua installate lateralmente. Può essere installato a destra o a sinistra. Contenitore principale da 40 litri, coperchio di contenimento laterale fisso e cassetto completo Pro. Larghezza modulo 550/600 mm	80.60.002	40.002.922.00 <b>L</b> G	289.–	312.–
<b>12</b> X40 L35 Vara	Schmales Komplettsystem für Küchenunterschranke mit seitlich installierten Multifunktionsarmaturen Laufen Vara Epop. Die Montage kann rechts oder links erfolgen. 40 Liter Hauptbehälter, Ablagedeckel seitlich fix und Komplettschubkasten Pro. Korpusbreite 600 mm Systema completo compatto per mobili da cucina con rubinetterie multifunzionali Laufen Vara Epop installate lateralmente. Può essere installato a destra o a sinistra. Contenitore principale da 40 litri, coperchio di contenimento laterale fisso e cassetto completo Pro. Larghezza modulo 600 mm	80.60.003	40.002.935.00 <b>L</b> G	315.–	341.–
	Bei Inanspruchnahme des Montageservice durch Laufen Schweiz** In caso di utilizzo del servizio di montaggio da parte di Laufen Svizzera**	80.60.003	40.002.935.80 G	315.–	341.–

## Müllex X-Line: Set-Angebote für bestehende Schubladenauszüge

Müllex X-Line: Offerta di set per guide cassette esistenti



## Preis CHF / Prezzo in CHF

Modell Modello	Set bestehend aus Set costituito da	Müllex-Nr. N. di Müllex	Artikel-Nr. N. di articolo	Exkl. MWST IVA esclusa	Inkl. MWST IVA inclusa
<b>13</b> X45 L35 Basic, Einbauhöhe L, 414 mm Altezza d'ingombro L, 414 mm	Schublade Basic 450 mm 80.41.101+ Abfalltrennbehälter X45 L35 80.51.101 System für bestehende Schubladenauszüge, Korpusbreite 450 mm Cassetto Basic 450 mm 80.41.101+ Contentitore per separazione rifiuti X45 L35 80.51.101 Sistema per guide cassette esistenti, larghezza modulo 450 mm	80.50.101	40.002.270.00 <b>L</b> G	179.–	193.–
<b>14</b> X45 M35 Basic, Einbauhöhe M, 367 mm Altezza d'ingombro M, 367 mm	Schublade Basic 450 mm 80.41.101+ Abfalltrennbehälter X45 M35 80.51.102 System für bestehende Schubladenauszüge, Korpusbreite 450 mm Cassetto Basic 450 mm 80.41.101+ Contentitore per separazione rifiuti X45 M35 80.51.102 Sistema per guide cassette esistenti, larghezza modulo 450 mm	80.50.103	40.002.271.00 <b>L</b> G	179.–	193.–
<b>14</b> X50 L35 Basic, Einbauhöhe L, 414 mm Altezza d'ingombro L, 414 mm	Schublade Basic 500 mm 80.41.201+ Abfalltrennbehälter X45 L35, 80.51.101 System für bestehende Schubladenauszüge, Korpusbreite 500 mm Cassetto Basic 500 mm 80.41.201+ Contentitore per separazione rifiuti X45 L35, 80.51.101 Sistema per guide cassette esistenti, larghezza modulo 500 mm	80.50.201	40.002.272.00 <b>L</b> G	179.–	193.–
<b>14</b> X50 M35 Basic, Einbauhöhe M, 367 mm Altezza d'ingombro M, 367 mm	Schublade Basic 500 mm 80.41.201+ Abfalltrennbehälter X45 M35 80.51.102 System für bestehende Schubladenauszüge, Korpusbreite 500 mm Cassetto Basic 500 mm 80.41.201+ Contentitore per separazione rifiuti X45 M35 80.51.102 Sistema per guide cassette esistenti, larghezza modulo 500 mm	80.50.203	40.002.273.00 <b>L</b> G	179.–	193.–
<b>15</b> X55 L7 Basic, Einbauhöhe L, 414 mm Altezza d'ingombro L, 414 mm	Schublade Basic 550 mm 80.41.301+ Abfalltrennbehälter X55 L7 80.51.303 System für bestehende Schubladenauszüge, Korpusbreite 550 mm Cassetto Basic 550 mm 80.41.301+ Contentitore per separazione rifiuti X55 L7 80.51.303 Sistema per guide cassette esistenti, larghezza modulo 550 mm	80.50.305	40.002.446.00 <b>L</b> G	203.–	219.–
<b>15</b> X55 M7 Basic, Einbauhöhe M, 367 mm Altezza d'ingombro M, 367 mm	Schublade Basic 550 mm 80.41.301+ Abfalltrennbehälter X55 M7 80.51.304 System für bestehende Schubladenauszüge, Korpusbreite 550 mm Cassetto Basic 550 mm 80.41.301+ Contentitore per separazione rifiuti X55 M7 80.51.304 Sistema per guide cassette esistenti, larghezza modulo 550 mm	80.50.307	40.002.447.00 <b>L</b> G	203.–	219.–

## Müllex X-Line: Set-Angebote für bestehende Schubladenauszüge

Müllex X-Line: Offerta di set per guide cassette esistenti



Preis CHF / Prezzo in CHF

Modell Modello	Set bestehend aus Set costituito da	Müllex-Nr. N. di Müllex	Artikel-Nr. N. di articolo	Exkl. MWST IVA esclusa	Inkl. MWST IVA inclusa
<b>16</b> X55 L5 Basic, Einbauhöhe L, 414 mm Altezza d'ingombro L, 414 mm	Schublade Basic 550 mm 80.41.301+ Abfalltrennbehälter X55 L5 80.51.301 System für bestehende Schubladenauszüge, Korpusbreite 550 mm Cassetto Basic 550 mm 80.41.301+ Contentitore per separazione rifiuti X55 L5 80.51.301 Sistema per guide cassette esistenti, larghezza modulo 550 mm	80.50.301	40.002.274.00 <b>L</b> G	232.–	251.–
<b>17</b> X55 M5 Basic, Einbauhöhe M, 367 mm Altezza d'ingombro M, 367 mm	Schublade Basic 550 mm 80.41.301+ Abfalltrennbehälter X55 M5 80.51.302 System für bestehende Schubladenauszüge, Korpusbreite 550 mm Cassetto Basic 550 mm 80.41.301+ Contentitore per separazione rifiuti X55 M5 80.51.302 Sistema per guide cassette esistenti, larghezza modulo 550 mm	80.50.303	40.002.275.00 <b>L</b> G	232.–	251.–
<b>17</b> X60 L7 Basic, Einbauhöhe L, 414 mm Altezza d'ingombro L, 414 mm	Schublade Basic 600 mm 80.41.401+ Abfalltrennbehälter X60 L7 80.51.403 System für bestehende Schubladenauszüge, Korpusbreite 600 mm Cassetto Basic 600 mm 80.41.401+ Contentitore per separazione rifiuti X60 L7 80.51.403 Sistema per guide cassette esistenti, larghezza modulo 600 mm	80.50.405	40.002.448.00 <b>L</b> G	203.–	219.–
<b>17</b> X60 M7 Basic, Einbauhöhe M, 367 mm Altezza d'ingombro M, 367 mm	Schublade Basic 600 mm 80.41.401+ Abfalltrennbehälter X60 M7 80.51.404 System für bestehende Schubladenauszüge, Korpusbreite 600 mm Cassetto Basic 600 mm 80.41.401+ Contentitore per separazione rifiuti X60 M7 80.51.404 Sistema per guide cassette esistenti, larghezza modulo 600 mm	80.50.389	40.002.449.00 <b>L</b> G	203.–	219.–
<b>18</b> X60 L5 Basic, Einbauhöhe L, 414 mm Altezza d'ingombro L, 414 mm	Schublade Basic 600 mm 80.41.401+ Abfalltrennbehälter X60 L5 80.51.401 System für bestehende Schubladenauszüge, Korpusbreite 600 mm Cassetto Basic 600 mm 80.41.401+ Contentitore per separazione rifiuti X60 L5 80.51.401 Sistema per guide cassette esistenti, larghezza modulo 600 mm	80.50.401	40.002.278.00 <b>L</b> G	232.–	251.–
<b>18</b> X60 M5 Basic, Einbauhöhe M, 367 mm Altezza d'ingombro M, 367 mm	Schublade Basic 600 mm 80.41.401+ Abfalltrennbehälter X60 M5 80.51.402 System für bestehende Schubladenauszüge, Korpusbreite 600 mm Cassetto Basic 600 mm 80.41.401+ Contentitore per separazione rifiuti X60 M5 80.51.402 Sistema per guide cassette esistenti, larghezza modulo 600 mm	80.50.403	40.002.279.00 <b>L</b> G	232.–	251.–

## Müllex X-Line: Set-Angebote für bestehende Schubladenauszüge

Müllex X-Line: Offerta di set per guide cassette esistenti



Preis CHF/Prezzo in CHF

Modell Modello	Set bestehend aus Set costituito da	Müllex-Nr. N. di Müllex	Artikel-Nr. N. di articolo	Exkl. MWST IVA esclusa	Inkl. MWST IVA inclusa
19 <b>X80 L6 Basic,</b> <b>Einbauhöhe L,</b> <b>414 mm</b> <b>Altezza d'ingombro L,</b> <b>414 mm</b>	Deckel Basic 800 mm 80.41.501+ Abfalltrennbehälter X80 L6 80.51.501 System für bestehende Schubladenauszüge, Korpusbreite 800 mm Coperchio Basic 800 mm 80.41.501+ Contentitore per separazione rifiuti X80 L6 80.51.501 Sistema per guide cassette esistenti, larghezza modulo 800 mm	80.50.501	40.002.282.00 L G	328.–	355.–
20 <b>X90 L6 Basic,</b> <b>Einbauhöhe L,</b> <b>414 mm</b> <b>Altezza d'ingombro L,</b> <b>414 mm</b>	Deckel Basic 900 mm 80.41.601+ Abfalltrennbehälter X80 L6 80.51.501 System für bestehende Schubladenauszüge, Korpusbreite 900 mm Coperchio Basic 900 mm 80.41.601+ Contentitore per separazione rifiuti X80 L6 80.51.501 Sistema per guide cassette esistenti, larghezza modulo 900 mm	80.50.601	40.002.283.00 L G	328.–	355.–
21 <b>X55 L7 Premium,</b> <b>Einbauhöhe L,</b> <b>414 mm</b> <b>Altezza d'ingombro L,</b> <b>414 mm</b>	Schublade Premium 550 mm 80.42.301+ Abfalltrennbehälter X55 L7 80.51.303 System für bestehende Schubladenauszüge, Korpusbreite 550 mm Cassetto Premium 550 mm 80.42.301+ Contentitore per separazione rifiuti X55 L7 80.51.303 Sistema per guide cassette esistenti, larghezza modulo 550 mm	80.50.306	40.002.450.00 L G	249.–	269.–
<b>X55 M7 Premium,</b> <b>Einbauhöhe M,</b> <b>367 mm</b> <b>Altezza d'ingombro M,</b> <b>367 mm</b>	Schublade Premium 550 mm 80.42.301+ Abfalltrennbehälter X55 M7 80.51.304 System für bestehende Schubladenauszüge, Korpusbreite 550 mm Cassetto Premium 550 mm 80.42.301+ Contentitore per separazione rifiuti X55 M7 80.51.304 Sistema per guide cassette esistenti, larghezza modulo 550 mm	80.50.308	40.002.451.00 L G	249.–	269.–

## Müllex X-Line: Set-Angebote für bestehende Schubladenauszüge

Müllex X-Line: Offerta di set per guide cassette esistenti



Preis CHF / Prezzo in CHF

Modell Modello	Set bestehend aus Set costituito da	Müllex-Nr. N. di Müllex	Artikel-Nr. N. di articolo	Exkl. MWST IVA esclusa	Inkl. MWST IVA inclusa
<b>22</b> X55 L5 Premium, Einbauhöhe L, 414 mm Altezza d'ingombro L, 414 mm	Schublade Premium 550 mm 80.42.301+ Abfalltrennbehälter X55 L5 80.51.301 System für bestehende Schubladenauszüge, Korpusbreite 550 mm Cassetto Premium 550 mm 80.42.301+ Contentitore per separazione rifiuti X55 L5 80.51.301 Sistema per guide cassette esistenti, larghezza modulo 550 mm	80.50.302	40.002.276.00 <b>L</b> G	278.–	301.–
<b>22</b> X55 M5 Premium, Einbauhöhe M, 367 mm Altezza d'ingombro M, 367 mm	Schublade Premium 550 mm 80.42.301+ Abfalltrennbehälter X55 M5 80.51.302 System für bestehende Schubladenauszüge Korpusbreite 550 mm Cassetto Premium 550 mm 80.42.301+ Contentitore per separazione rifiuti X55 M5 80.51.302 Sistema per guide cassette esistenti, larghezza modulo 550 mm	80.50.304	40.002.277.00 <b>L</b> G	278.–	301.–
<b>23</b> X60 L7 Premium, Einbauhöhe L, 414 mm Altezza d'ingombro L, 414 mm	Schublade Premium 600 mm 80.42.401+ Abfalltrennbehälter X60 L7 80.51.403 System für bestehende Schubladenauszüge, Korpusbreite 600 mm Cassetto Premium 600 mm 80.42.401+ Contentitore per separazione rifiuti X60 L7 80.51.403 Sistema per guide cassette esistenti, larghezza modulo 600 mm	80.50.406	40.002.452.00 <b>L</b> G	249.–	269.–
<b>23</b> X60 M7 Premium, Einbauhöhe M, 367 mm Altezza d'ingombro M, 367 mm	Schublade Premium 600 mm 80.42.401+ Abfalltrennbehälter X60 M7 80.51.404 System für bestehende Schubladenauszüge, Korpusbreite 600 mm Cassetto Premium 600 mm 80.42.401+ Contentitore per separazione rifiuti X60 M7 80.51.404 Sistema per guide cassette esistenti, larghezza modulo 600 mm	80.50.390	40.002.453.00 <b>L</b> G	249.–	269.–
<b>24</b> X60 L5 Premium, Einbauhöhe L, 414 mm Altezza d'ingombro L, 414 mm	Schublade Premium 600 mm 80.42.401+ Abfalltrennbehälter X60 L5 80.51.401 System für bestehende Schubladenauszüge, Korpusbreite 600 mm Cassetto Premium 600 mm 80.42.401+ Contentitore per separazione rifiuti X60 L5 80.51.401 Sistema per guide cassette esistenti, larghezza modulo 600 mm	80.50.402	40.002.280.00 <b>L</b> G	278.–	301.–
<b>24</b> X60 M5 Premium, Einbauhöhe M, 367 mm Altezza d'ingombro M, 367 mm	Schublade Premium 600 mm 80.42.401+ Abfalltrennbehälter X60 M5 80.51.402 System für bestehende Schubladenauszüge, Korpusbreite 600 mm Cassetto Premium 600 mm 80.42.401+ Contentitore per separazione rifiuti X60 M5 80.51.402 Sistema per guide cassette esistenti, larghezza modulo 600 mm	80.50.404	40.002.281.00 <b>L</b> G	278.–	301.–

Masszeichnungen auf Seite 391. / Disegni tecnici a pag. 391.

## Müllex X-Line: Einzelkomponenten / Müllex X-Line: Componenti singoli

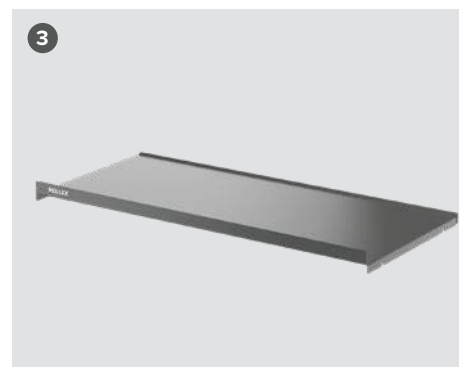

## Preis CHF / Prezzo in CHF

Modell Modello	Beschreibung Descrizione	Müllex-Nr. N. di Müllex	Artikel-Nr. N. di articolo	Exkl. MWST IVA esclusa	Inkl. MWST IVA inclusa	
1	<b>Schublade Basic Cassetto Basic 450 mm</b>	Basic-Schublade für Abfall-System mit Korpusbreite 450 mm. B 404 × T 358 × H 50 mm, anthrazit, Kunststoff Cassetto Basic per sistema di raccolta rifiuti con larghezza modulo 450 mm. L 404 × P 358 × A 50 mm, antracite, plastica	80.41.101	40.002.254.00 <b>L</b> G	35.–	38.–
	<b>Schublade Basic Cassetto Basic 500 mm</b>	Basic-Schublade für Abfall-System mit Korpusbreite 500 mm. B 454 × T 358 × H 50 mm, anthrazit, Kunststoff Cassetto Basic per sistema di raccolta rifiuti con larghezza modulo 500 mm. L 454 × P 358 × A 50 mm, antracite, plastica	80.41.201	40.002.255.00 <b>L</b> G	35.–	38.–
	<b>Schublade Basic Cassetto Basic 550 mm</b>	Basic-Schublade für Abfall-System mit Korpusbreite 550 mm. B 504 × T 358 × H 50 mm, anthrazit, Kunststoff Cassetto Basic per sistema di raccolta rifiuti con larghezza modulo 550 mm. L 504 × P 358 × A 50 mm, antracite, plastica	80.41.301	40.002.256.00 <b>L</b> G	35.–	38.–
	<b>Schublade Basic Cassetto Basic 600 mm</b>	Basic-Schublade für Abfall-System mit Korpusbreite 600 mm. B 554 × T 358 × H 50 mm, anthrazit, Kunststoff Cassetto Basic per sistema di raccolta rifiuti con larghezza modulo 600 mm. L 554 × P 358 × A 50 mm, antracite, plastica	80.41.401	40.002.257.00 <b>L</b> G	35.–	38.–
2	<b>Schublade Premium Cassetto Premium 550 mm</b>	Premium-Schublade für Abfall-System mit Korpusbreite 550 mm. B 500 × T 357 × H 68 mm, anthrazit, Kunststoff inkl. 2 Einlegeshalen, Volumen 0,9+1,3 Liter Cassetto Premium per sistema di raccolta rifiuti con larghezza modulo 550 mm. L 500 × P 357 × A 68 mm, antracite, plastica incl. 2 piastre inseribili, volume 0,9+1,3 litri	80.42.301	40.002.258.00 <b>L</b> G	81.–	88.–
	<b>Schublade Premium Cassetto Premium 600 mm</b>	Premium-Schublade für Abfall-System mit Korpusbreite 600 mm. B 550 × T 357 × H 68 mm, anthrazit, Kunststoff inkl. 2 Einlegeshalen, Volumen 0,9+1,3 Liter Cassetto Premium per sistema di raccolta rifiuti con larghezza modulo 600 mm. L 550 × P 357 × A 68 mm, antracite, plastica incl. 2 piastre inseribili, volume 0,9+1,3 litri	80.42.401	40.002.259.00 <b>L</b> G	81.–	88.–
3	<b>Deckel Basic Coperchio Basic 800 mm</b>	Metalldeckel für Abfall-System mit Korpusbreite 800 mm. B 754 × T 345 × H 43 mm, anthrazit, Metall Coperchio in metallo per sistema di raccolta rifiuti con larghezza modulo 800 mm. L 754 × P 345 × A 43 mm, antracite, metallo	80.41.501	40.002.260.00 <b>L</b> G	72.–	78.–
	<b>Deckel Basic Coperchio Basic 900 mm</b>	Metalldeckel für Abfall-System mit Korpusbreite 900 mm. B 854 × T 345 × H 43 mm, anthrazit, Metall Coperchio in metallo per sistema di raccolta rifiuti con larghezza modulo 900 mm. L 854 × P 345 × A 43 mm, antracite, metallo	80.41.601	40.002.261.00 <b>L</b> G	72.–	78.–
4	<b>Trennsteg X Separatore X</b>	Der Trennsteg unterteilt einen 35 oder 40 Liter Hauptbehälter, so dass zwei 17 Liter Abfallsäcke eingespannt werden können. Il separatore divide il contenitore principale da 35 o 40 litri in modo da poter bloccare due sacchi di rifiuti da 17 litri.	12927	40.002.529.00 <b>L</b> G	19.–	21.–

## Müllex X-Line: Einzelkomponenten / Müllex X-Line: Componenti singoli



## Preis CHF / Prezzo in CHF

Modell Modello	Beschreibung Descrizione	Müllex-Nr. N. di Müllex	Artikel-Nr. N. di articolo	Exkl. MWST IVA esclusa	Inkl. MWST IVA inclusa
<b>5</b> Abfalltrennbehälter Contenitore per separazione rifiuti X45 L35	Behälter für Abfall-System mit Korpusbreite 450 mm. Einbauhöhe L, 414 mm, Volumen 40 Liter, anthrazit, Kunststoff Contenitore per sistema di raccolta rifiuti con larghezza modulo 450 mm. Altezza d'ingombro L, 414 mm, volume 40 litri, antracite, plastica	80.51.101	40.002.262.00 <b>L</b> G	144.–	156.–
<b>5</b> Abfalltrennbehälter Contenitore per separazione rifiuti X45 M35	Behälter für Abfall-System mit Korpusbreite 450 mm. Einbauhöhe M, 367 mm, Volumen 35 Liter, anthrazit, Kunststoff Contenitore per sistema di raccolta rifiuti con larghezza modulo 450 mm. Altezza d'ingombro M, 367 mm, volume 35 litri, antracite, plastica	80.51.102	40.002.263.00 <b>L</b> G	144.–	156.–
<b>6</b> Abfalltrennbehälter Contenitore per separazione rifiuti X55 L7	Behälterkombination für Abfall-System mit Korpusbreite 550 mm. Einbauhöhe L, 414 mm, Volumen 40+12,5 Liter, anthrazit / elfenbeinweiss, Kunststoff Combinazione di contenitori per sistema di raccolta rifiuti con larghezza modulo 550 mm. Altezza d'ingombro L, 414 mm, volume 40+12,5 litri, antracite / bianco avorio, plastica	80.51.303	40.002.442.00 <b>L</b> G	168.–	182.–
<b>6</b> Abfalltrennbehälter Contenitore per separazione rifiuti X55 M7	Behälterkombination für Abfall-System mit Korpusbreite 550 mm. Einbauhöhe M, 367 mm, Volumen 35+11,5 Liter, anthrazit / elfenbeinweiss, Kunststoff Combinazione di contenitori per sistema di raccolta rifiuti con larghezza modulo 550 mm. Altezza d'ingombro M, 367 mm, volume 35+11,5 litri, antracite / bianco avorio, plastica	80.51.304	40.002.443.00 <b>L</b> G	168.–	182.–
<b>7</b> Abfalltrennbehälter Contenitore per separazione rifiuti X55 L5	Behälterkombination für Abfall-System mit Korpusbreite 550 mm. Einbauhöhe L, 414 mm, Volumen 40+4+4+(1,4+1,4) Liter, anthrazit / elfenbeinweiss, Kunststoff Combinazione di contenitori per sistema di raccolta rifiuti con larghezza modulo 550 mm. Altezza d'ingombro L, 414 mm, volume 40+4+4+(1,4+1,4) litri, antracite / bianco avorio, plastica	80.51.301	40.002.265.00 <b>L</b> G	197.–	213.–
<b>7</b> Abfalltrennbehälter Contenitore per separazione rifiuti X55 M5	Behälterkombination für Abfall-System mit Korpusbreite 550 mm. Einbauhöhe M, 367 mm, Volumen 35+4+4+(0,9+0,9) Liter, anthrazit / elfenbeinweiss, Kunststoff Combinazione di contenitori per sistema di raccolta rifiuti con larghezza modulo 550 mm. Altezza d'ingombro M, 367 mm, volume 35+4+4+(0,9+0,9) litri, antracite / bianco avorio, plastica	80.51.302	40.002.266.00 <b>L</b> G	197.–	213.–

## Müllex X-Line: Einzelkomponenten / Müllex X-Line: Componenti singoli



## Preis CHF / Prezzo in CHF

Modell Modello	Beschreibung Descrizione	Müllex-Nr. N. di Müllex	Artikel-Nr. N. di articolo	Exkl. MWST IVA esclusa	Inkl. MWST IVA inclusa
8 <b>Abfalltrennbehälter Contentore per separazione rifiuti X60 L7</b>	Behälterkombination für Abfall-System mit Korpusbreite 600 mm. Einbauhöhe L, 414 mm, Volumen 40 + 18 Liter, anthrazit / elfenbeinweiss, Kunststoff Combinazione di contenitori per sistema di raccolta rifiuti con larghezza modulo 600 mm. Altezza d'ingombro L, 414 mm, volume 40 + 18 litri, antracite / bianco avorio, plastica	80.51.403	40.002.444.00 L G	168.–	182.–
<b>Abfalltrennbehälter Contentore per separazione rifiuti X60 M7</b>	Behälterkombination für Abfall-System mit Korpusbreite 600 mm. Einbauhöhe M, 367 mm, Volumen 35 + 15 Liter, anthrazit / elfenbeinweiss, Kunststoff Combinazione di contenitori per sistema di raccolta rifiuti con larghezza modulo 600 mm. Altezza d'ingombro M, 367 mm, volume 35 + 15 litri, antracite / bianco avorio, plastica	80.51.404	40.002.445.00 L G	168.–	182.–
9 <b>Abfalltrennbehälter Contentore per separazione rifiuti X60 L5</b>	Behälterkombination für Abfall-System mit Korpusbreite 600 mm. Einbauhöhe L, 414 mm, Volumen 40 + 8 + 5 + (1,6 + 1,5) Liter, anthrazit / elfenbeinweiss, Kunststoff Combinazione di contenitori per sistema di raccolta rifiuti con larghezza modulo 600 mm. Altezza d'ingombro L, 414 mm, volume 40 + 8 + 5 + (1,6 + 1,5) litri, antracite / bianco avorio, plastica	80.51.401	40.002.267.00 L G	197.–	213.–
<b>Abfalltrennbehälter Contentore per separazione rifiuti X60 M5</b>	Behälterkombination für Abfall-System mit Korpusbreite 600 mm. Einbauhöhe M, 367 mm, Volumen 35 + 8 + 5 + (1,0 + 0,5) Liter, anthrazit / elfenbeinweiss, Kunststoff Combinazione di contenitori per sistema di raccolta rifiuti con larghezza modulo 600 mm. Altezza d'ingombro M, 367 mm, volume 35 + 8 + 5 + (1,0 + 0,5) litri, antracite / bianco avorio, plastica	80.51.402	40.002.268.00 L G	197.–	213.–
10 <b>Abfalltrennbehälter Contentore per separazione rifiuti X80 L6</b>	Behälterkombination für Abfall-System mit Korpusbreite 800 mm. Einbauhöhe L, 414 mm, Volumen 40 + 18 + 8 + 5 + (1,6 + 1,5) Liter, anthrazit / elfenbeinweiss, Kunststoff Combinazione di contenitori per sistema di raccolta rifiuti con larghezza modulo 800 mm. Altezza d'ingombro L, 414 mm, volume 40 + 18 + 8 + 5 + (1,6 + 1,5) litri, antracite / bianco avorio, plastica	80.51.501	40.002.269.00 L G	256.–	277.–

## Müllex X-Line: Einzelkomponenten / Müllex X-Line: Componenti singoli

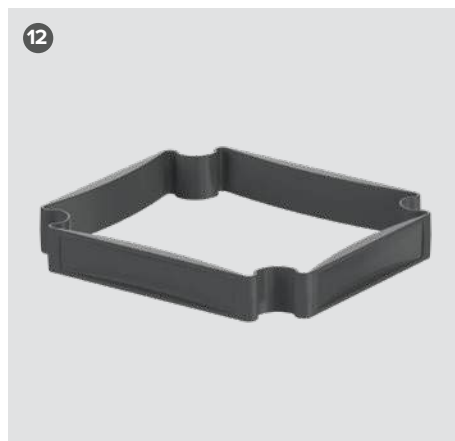
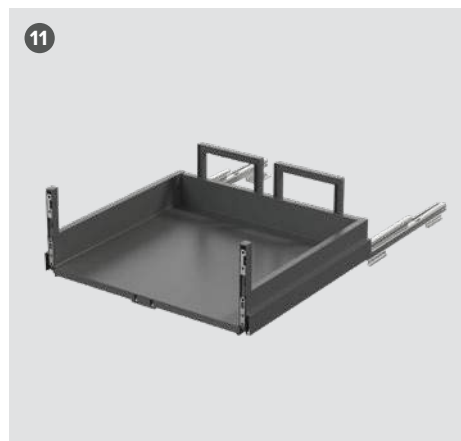

**i** Der vormontierte Komplettschubkasten mit dem verstärkten Kunststoffboden ist bis zu 70 kg belastbar. Zur schnellen Bodenmontage auf dem bewährten Zargenführungssystem Nova Pro Scala von Grass.

Il cassetto completo preassemblato con base in plastica rinforzata può sopportare carichi fino a 70 kg. Per un rapido montaggio a pavimento sul collaudato sistema di guida del telaio Nova Pro Scala di Grass.

## Preis CHF / Prezzo in CHF

Modell Modello	Beschreibung Descrizione	Müllex-Nr. N. di Müllex	Artikel-Nr. N. di articolo	Exkl. MWST IVA esclusa	Inkl. MWST IVA inclusa
<b>Komplettschubkasten Cassetto completo 45 Pro</b>	Für Korpusbreite 450 mm. Per larghezza modulo di 450 mm.	80.61.101	40.002.923.00 <b>L</b> G	149.–	161.–
<b>Komplettschubkasten Cassetto completo 50 Pro</b>	Für Korpusbreite 500 mm. Per larghezza modulo di 500 mm.	80.61.201	40.002.924.00 <b>L</b> G	149.–	161.–
<b>Komplettschubkasten Cassetto completo 55 Pro</b>	Für Korpusbreite 550 mm. Per larghezza modulo di 550 mm.	80.61.301	40.002.925.00 <b>L</b> G	165.–	178.–
<b>Komplettschubkasten Cassetto completo 60 Pro</b>	Für Korpusbreite 600 mm. Per larghezza modulo di 600 mm.	80.61.401	40.002.926.00 <b>L</b> G	165.–	178.–
<b>Spannrahmen 4-Liter Telaio di bloccaggio da 4 litri</b>	Spannrahmen zum Einspannen von Abfallsäcken Telaio di bloccaggio per fissare i sacchi per rifiuti	13224	40.002.927.00 <b>L</b> G	6.–	7.–
<b>Spannrahmen 5-Liter Telaio di bloccaggio da 5 litri</b>	Spannrahmen zum Einspannen von Abfallsäcken Telaio di bloccaggio per fissare i sacchi per rifiuti	13223	40.002.928.00 <b>L</b> G	6.–	7.–
<b>Spannrahmen 8-Liter Telaio di bloccaggio da 8 litri</b>	Spannrahmen zum Einspannen von Abfallsäcken Telaio di bloccaggio per fissare i sacchi per rifiuti	13222	40.002.929.00 <b>L</b> G	7.–	8.–
<b>Spannrahmen 11,5/12,5-Liter Telaio di bloccaggio da 11,5/12,5 litri</b>	Spannrahmen zum Einspannen von Abfallsäcken Telaio di bloccaggio per fissare i sacchi per rifiuti	13225	40.002.930.00 <b>L</b> G	8.–	9.–
<b>Spannrahmen 11/15/18-Liter Telaio di bloccaggio da 11/15/18 litri</b>	Spannrahmen zum Einspannen von Abfallsäcken Telaio di bloccaggio per fissare i sacchi per rifiuti	13219	40.002.931.00 <b>L</b> G	9.–	10.–
<b>Fuss-Öffner Apertura a pedale</b>	Fuss-Öffner für alle handelsüblichen Auszüge. Bauart: Sichtbar, mechanisch Apertura a pedale per tutti i cassettei estraibili standard. Tipo struttura: visibile, meccanico	13390	40.002.932.00 <b>L</b> G	59.–	64.–
<b>Tip-Öffner Apertura a pressione</b>	Tip-Öffner für Fertigschublade Pro. Bauart: unsichtbar, mechanisch Apertura a pressione per cassettei pronti all'uso Pro. Tipo struttura: invisibile, meccanico	13600	40.002.933.00 <b>L</b> G	69.–	75.–
<b>Sensomatic Single Set Sensomatic Single Set</b>	Sensomatic Single Set für alle handelsüblichen Auszüge. Bauart: unsichtbar, elektromechanisch Sensomatic Single Set per tutti i cassettei estraibili standard. Tipo struttura: invisibile, elettromeccanico	13455	40.002.934.00 <b>L</b> G	195.–	211.–

## Müllex BOXX



## Preis CHF / Prezzo in CHF

Modell Modello	Beschreibung Descrizione	Müllex-Nr. N. di Müllex	Artikel-Nr. N. di articolo	Exkl. MWST IVA esclusa	Inkl. MWST IVA inclusa
<b>1</b> Müllex BOXX 40-R	40-er und 50-er Korpus / inkl. Montageset / Netto Inhalt: 1×41l / Passend für: 35- und 17-Liter-Säcke Corpo da 40 e 50 cm / kit di montaggio incluso / contenuto netto: 1×41l / adatto per sacchi da 35 e 17 litri	5059.01	40.001.023.00 <b>L</b> G	347.–	375.–
	Ablage-Adapter mittel, Paar 45 mm, für 45-er Korpus Coppia di adattatori da 45 mm per ripiano medio, per telaio da 45	11783	40.001.684.00 <b>L</b> G	10.–	11.–
<b>2</b> Müllex BOXX 55/60-R BIO	55-er und 60-er Korpus / inkl. Montageset / Netto Inhalt: 1×41l, 1×5l / Passend für: 35- und 17-Liter-Säcke Corpo da 55 e 60 cm / kit di montaggio incluso / contenuto netto: 1×41l, 1×5l / adatto per sacchi da 35 e 17 litri	5069.01	40.001.024.00 <b>L</b> G	427.–	462.–
<b>3</b> Müllex Euro BOXX 55/60-R	Speziell für EURO-Norm Küchen. Gleiche Ausführung wie oben. Mit 16-Liter Beistellbehälter anstelle Grünkübel und Zusatzbehälter. Specifico per cucine Euronorma. Modello come sopra. Con contenitore da 16 litri invece del secchio verde e del contenitore supplementare.	5360.00	40.001.051.00 <b>L</b> G	396.–	428.–

## Müllex Heavy Bag





Die selbststehenden Heavy Bag Wertstoffsammeltaschen können in Küche, Vorratsraum, Waschküche, Garage oder Gartensitzplatz eingesetzt werden. Unentbehrlich für Haushalt und Alltag, wenn es um die sinnvolle Sammlung von Wertstoffen geht: Glas, Karton, Papier, Blechdosen, PET und vieles mehr.

Le borse autoportanti Heavy Bag per la raccolta differenziata dei rifiuti sono utilizzabili in qualsiasi ambiente: cucina, dispensa, lavanderia, garage o angolo relax nel giardino. Indispensabili nell'uso quotidiano e nel governo della casa per una raccolta razionale di materiali riciclabili come vetro, cartone, carta, lattine, PET e molto altro.

- selbststehend
- vielseitig einsetzbar
- hochwertige LKW-Blache
- 40 kg belastbar
- leicht zu reinigen
- autoportanti
- per un uso polivalente
- in tela da camion di alta qualità
- capacità di carico di 40 kg
- di facile pulizia



Preis CHF / Prezzo in CHF

Modell Modello	Beschreibung Descrizione	Dimensionen* Dimensioni*	Artikel-Nr. N. di articolo	Exkl. MWST IVA esclusa	Inkl. MWST IVA inclusa
1 Müllex Heavy Bag	Wertstoffsammeltasche ohne Trennfach, schwarz, matt Borsa per la raccolta differenziata senza divisorio, nero opaco	450 × 230 × 470	40.001.881.00  G	39.90	43.–
2 Müllex Heavy Bag	Wertstoffsammeltasche mit Trennfach, schwarz, matt Borsa per la raccolta differenziata con divisorio, nero opaco	450 × 230 × 470	40.001.882.00  G	39.90	43.–

\* Dimensionen in mm / Dimensioni in mm

# Masszeichnungen / Disegni tecnici

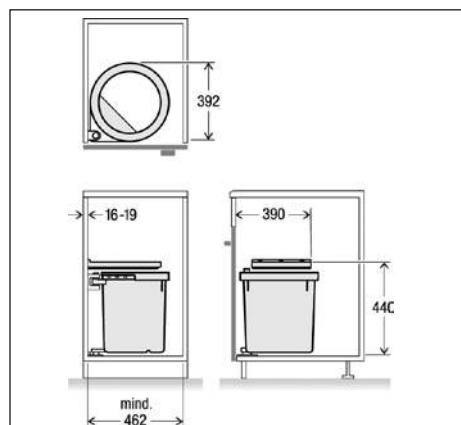

1 D-Line D50 L1

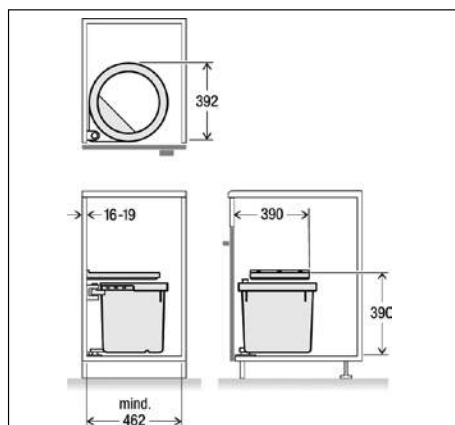

2 D-Line D50 M1

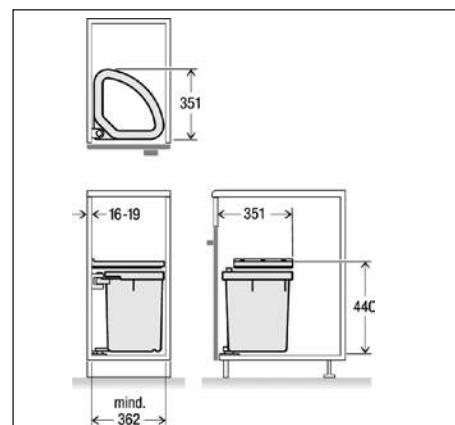

3 D-Line D40 L3

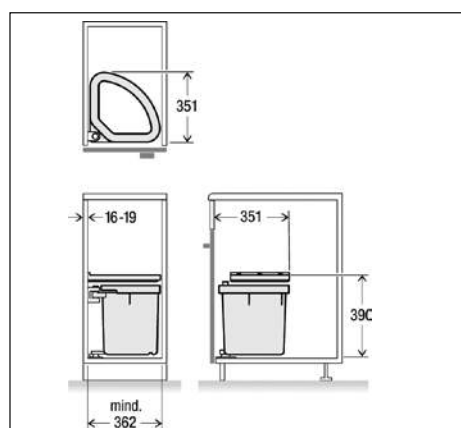

4 D-Line D40 M3

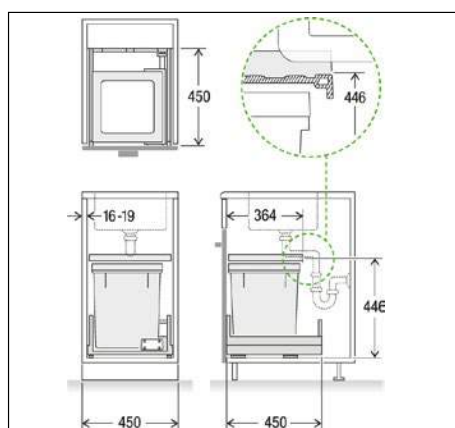

1 X-Line X45 L35 Basic Pro

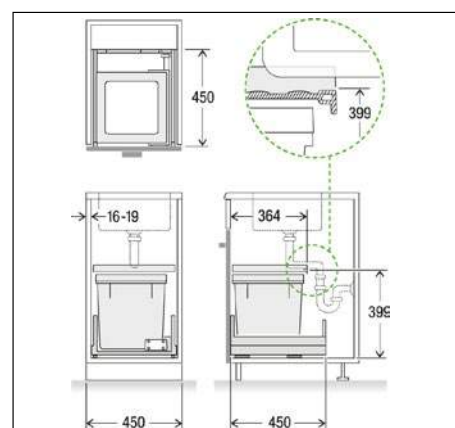

1 X-Line X45 M35 Basic Pro

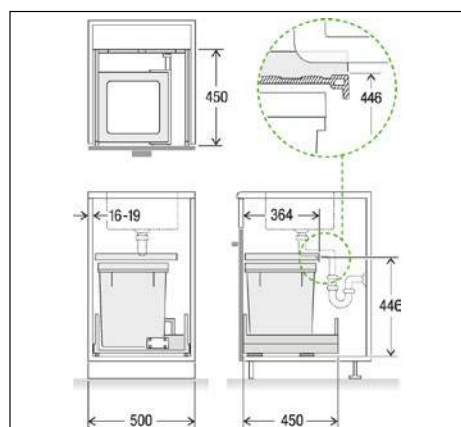

2 X-Line X50 L35 Basic Pro

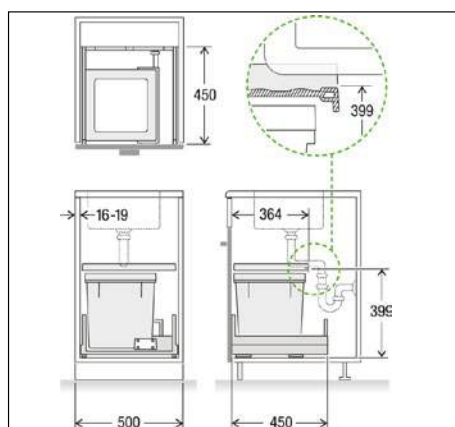

2 X-Line X50 M35 Basic Pro

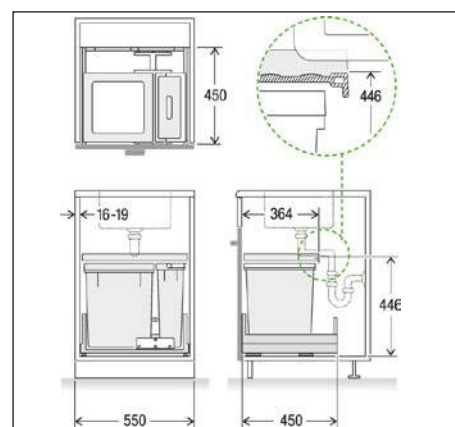

3 X-Line X55 L7 Basic Pro

7 X-Line X55 L7 Premium Pro

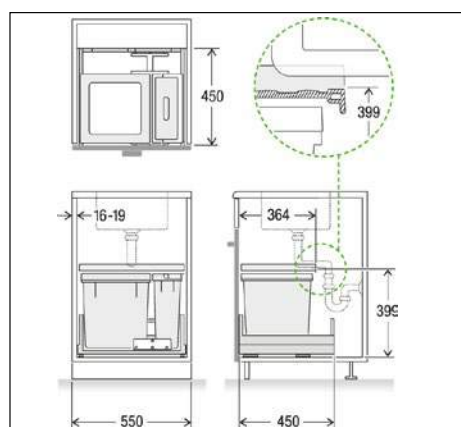

3 X-Line X55 M7 Basic Pro

7 X-Line X55 M7 Premium Pro

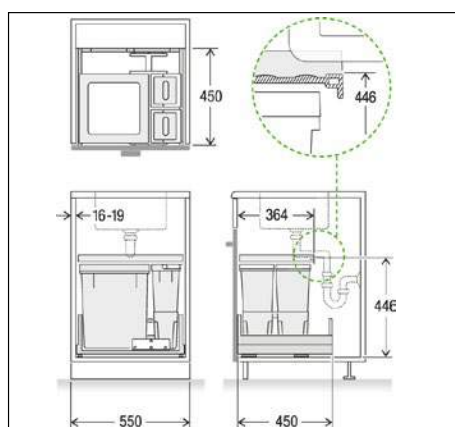

4 X-Line X55 L5 Basic Pro

8 X-Line X55 L5 Premium Pro

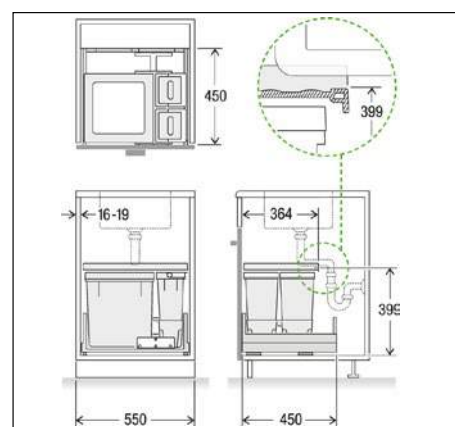

4 X-Line X55 M5 Basic Pro

8 X-Line X55 M5 Premium Pro

Masszeichnungen / Disegni tecnici

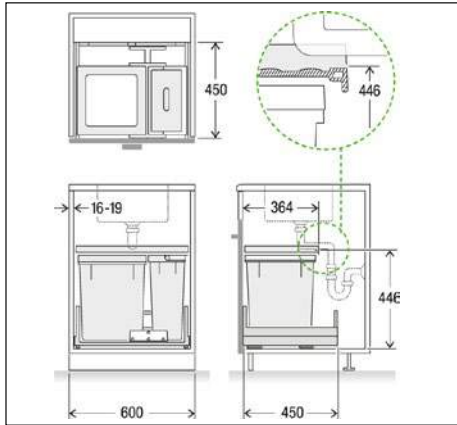

5 X-Line X60 L7 Basic Pro 9 X-Line X60 L7 Premium Pro

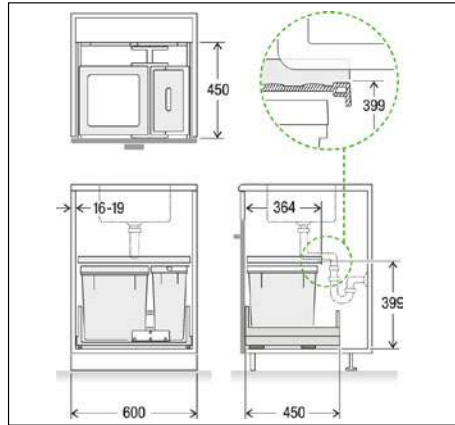

5 X-Line X60 M7 Basic Pro 9 X-Line X60 M7 Premium Pro

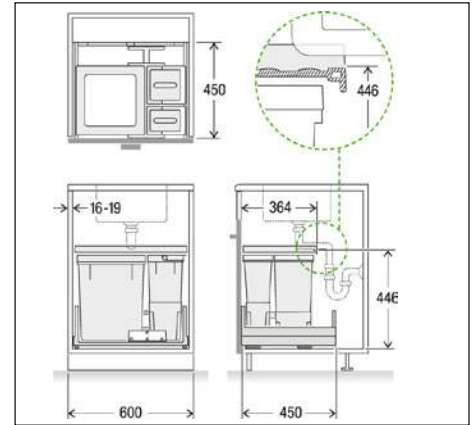

6 X-Line X60 L5 Basic Pro 10 X-Line X60 L5 Premium Pro

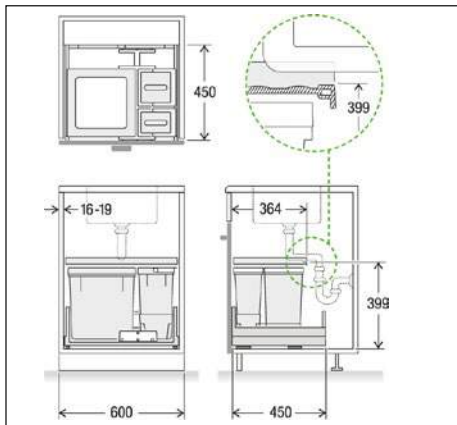

6 X-Line X60 M5 Basic Pro 10 X-Line X60 M5 Premium Pro

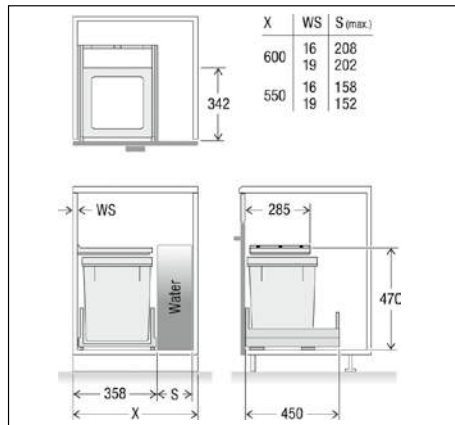

11 X-Line X40 L35 Pro Water

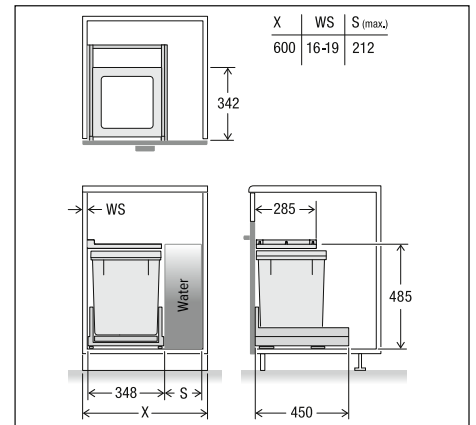

12 X-Line X40 L35 Vara

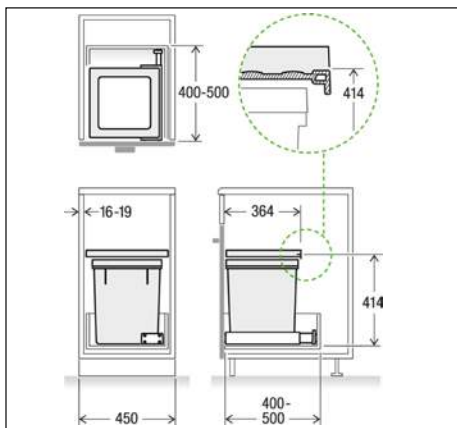

13 X-Line X45 L35 Basic

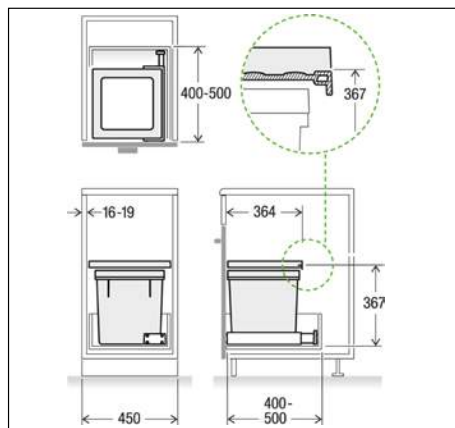

13 X-Line X45 M35 Basic

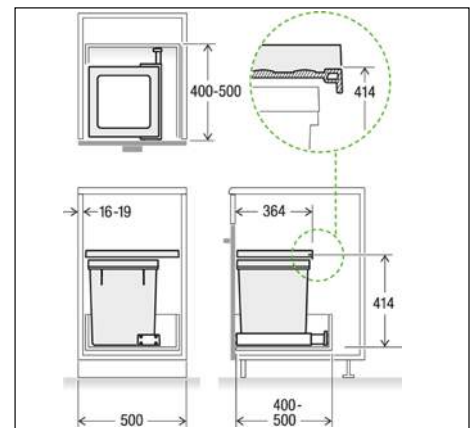

14 X-Line X50 L35 Basic

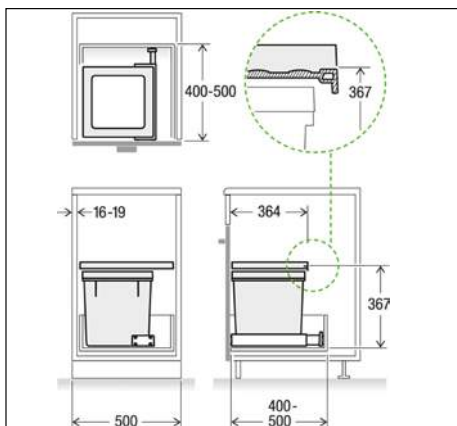

14 X-Line X50 M35 Basic

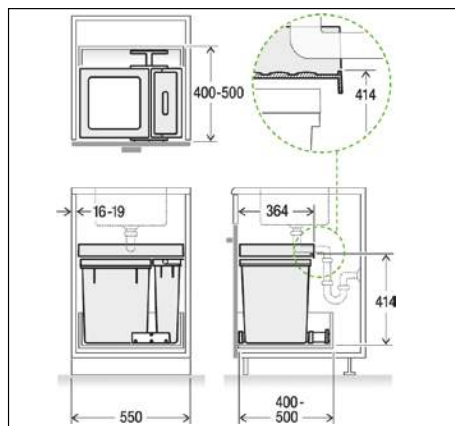

15 X-Line X55 L7 Basic 21 X-Line X55 L7 Premium

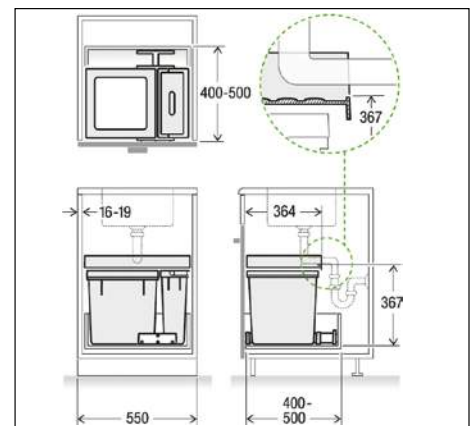

15 X-Line X55 M7 Basic 21 X-Line X55 M7 Premium

Masszeichnungen / Disegni tecnici

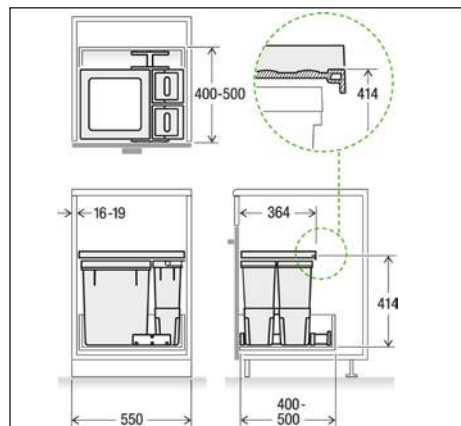

16 X-Line X55 L5 Basic 22 X-Line X55 L5 Premium

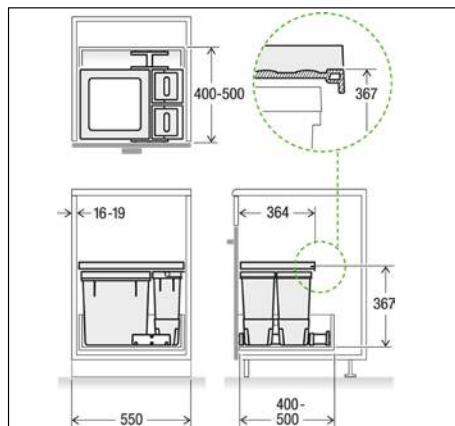

16 X-Line X55 M5 Basic 22 X-Line X55 M5 Premium

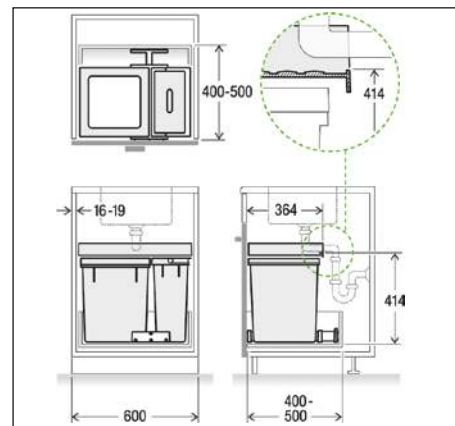

17 X-Line X60 L7 Basic 23 X-Line X60 L7 Premium

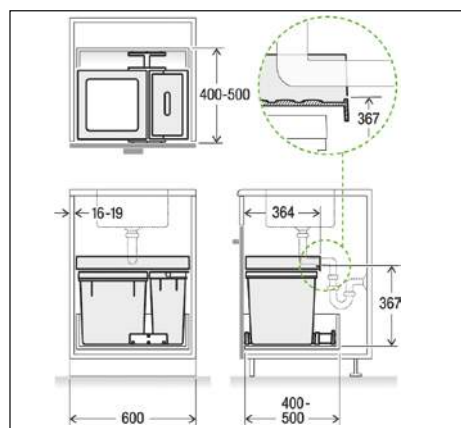

17 X-Line X60 M7 Basic 23 X-Line X60 M7 Premium

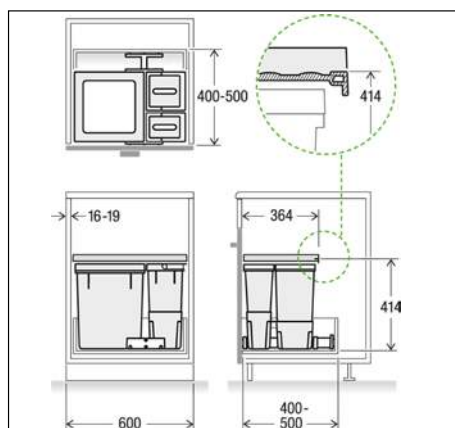

18 X-Line X60 L5 Basic 24 X-Line X60 L5 Premium

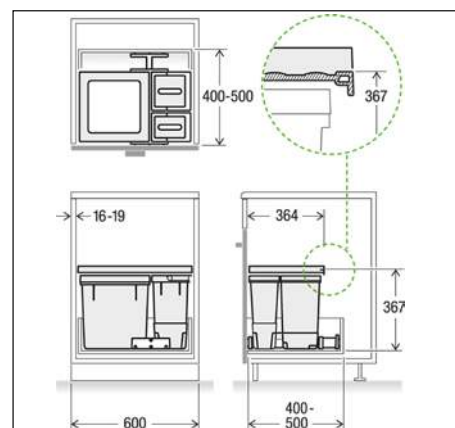

18 X-Line X60 M5 Basic 24 X-Line X60 M5 Premium

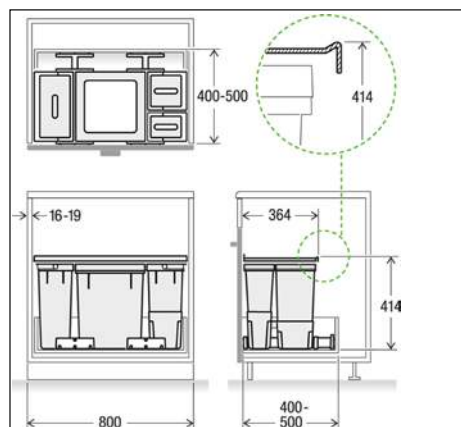

19 X-Line X80 L6 Basic

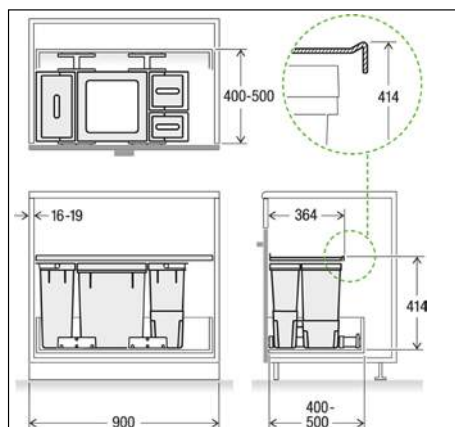

20 X-Line X90 L6 Basic

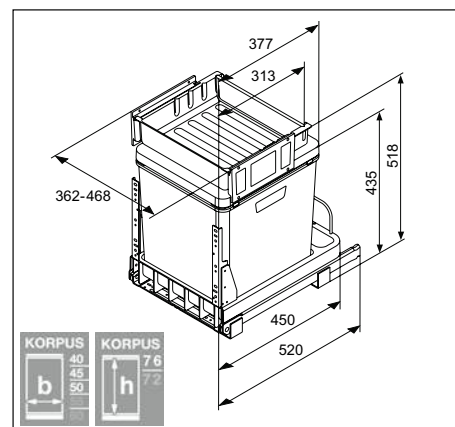

1 Müllex BOXX 40-R

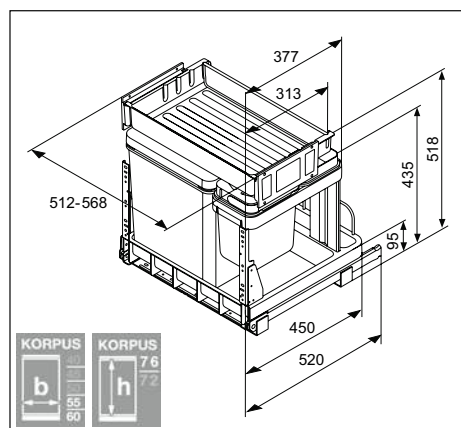

2 Müllex BOXX 55/60-R Bio

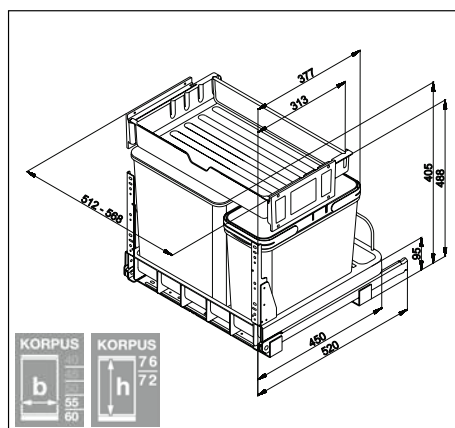

3 Müllex Euro BOXX 55/60-R







# Variantencode – Kurz erklärt

## Codice variante – Spiegato in breve

Wir haben die Bestellabwicklung für Sie vereinfacht. Mit der Einführung des Variantencodes haben wir unsere Artikelnummern um den Suffix .xx erweitert. Der Austausch von Zug- und Druckknöpfen und beschichteten Ventilbestandteilen kann nun einfach mit dem Variantencode direkt bei der Bestellung getätigt werden.

Abbiamo semplificato il processo di ordinazione. Con l'introduzione del codice variante, abbiamo aggiunto il suffisso .xx ai nostri numeri di articolo. Ora è possibile effettuare direttamente la sostituzione dei pomelli e dei pulsanti e componenti piletta con rivestimento semplicemente tramite il codice variante al momento dell'ordinazione.

Artikel-Nr. 00.000.000.XX  
Articolo n. 00.000.000.XX

### .00 / Standardlieferungsumfang

#### .00 / Fornitura standard

Sie erkennen den **Standardlieferungsumfang** der Suter Spülen und Becken am erweiterten Artikelcode xx.xxx.xxx.**00**. Die Ventilbestandteile werden in Edelstahl geliefert, mit Zugknopf Advant, Prime oder Drehknopf. Il codice articolo esteso xx.xxx.xxx.**00** è un codice per riconoscere il corredo di **fornitura standard** dei lavelli Suter. Le pilette sono fornite in acciaio inox, con pomolo Advant, Prime o pomolo girevole.



### .01 / Austausch Zug- und Druckknopf

#### .01 / Sostituzione del pomolo e del pulsante

Bestellen Sie die Spülen oder Becken mit der Variantenerweiterung xx.xxx.xxx.**01**. Austausch des Standard Zugknopfes mit dem Modell Ihrer Wahl (wählen Sie hier ein Modell mit der Erweiterung der Artikelnummer xx.xxx.xxx.**01** auf Seite 367–369). Der Bruttoverkaufspreis des Austausch Zug- und Druckknopfes ist um CHF 24.– bzw. CHF 45.– reduziert. Ordinate i lavelli con la variante estesa xx.xxx.xxx.**01**. Sostituzione del pomolo standard con un modello di vostra scelta (selezionate un modello con l'estensione del numero di articolo xx.xxx.xxx.**01** a pagina 367–369). Il prezzo di vendita lordo del pomolo e del pulsante sostitutivo è ridotto di CHF 24.– o CHF 45.–.



### .02 / Austausch beschichtete Ventilbestandteile

#### .02 / Sostituzione dei componenti piletta con rivestimento

Bestellen Sie die Spülen oder Becken mit der Variantenerweiterung xx.xxx.xxx.**02**. Die Ventilbestandteile mit der Oberfläche Edelstahl werden nach Ihrer Wahl ausgetauscht. Beschichtete Ventilbestandteile finden Sie auf Seite 188, 190 und 196 (wählen Sie hier die Modelle mit der Artikelnummer xx.xxx.xxx.**02**). Die Bruttopreise beinhalten den Mehrpreis für die beschichteten Ventilbestandteile gegenüber des Standards mit Oberfläche Edelstahl.

Ordinate i lavelli con la variante estesa xx.xxx.xxx.**02**. I componenti piletta con superficie in acciaio inox vengono sostituiti in base alla vostra scelta. Trovate i componenti piletta sostitutivi con rivestimento a pagina 188, 190 e 196 (selezionate qui i modelli con il numero di articolo xx.xxx.xxx.**02**). I prezzi includono il sovrapprezzo per i componenti piletta con rivestimento rispetto alla superficie standard in acciaio inox.



### .03 / Austausch Zug- und Druckknopf und beschichtete Ventilbestandteile

#### .03 / Sostituzione del pomolo o del pulsante e dei componenti piletta con rivestimento

Bestellen Sie das Becken mit der Variantenerweiterung xx.xxx.xxx.**03** und Ihre gewünschten Bestandteile wie beschrieben bei den Varianten **.01** und **.02**.

Ordinate il lavello con la variante estesa xx.xxx.xxx.**03** e i componenti desiderati come descritto per le varianti **.01** und **.02**.

# Preise für Austausch Zug- und Druckknopf

## Prezzi per sostituzione del pomolo e del pulsante

Name Nome	Beschreibung Descrizione	Material / Oberfläche Materiale / Superficie	Artikel-Nr. <sup>1</sup> N. di articolo	Exkl. MWST IVA esclusa	Inkl. MWST IVA inclusa	Artikel-Nr. <sup>1</sup> N. di articolo	Exkl. MWST IVA esclusa	Inkl. MWST IVA inclusa	
<b>Pinocchio<sup>2</sup></b>	Zugknopf, komplett, massiv Metall, mit Rosette D = ø 25 mm Pomolo, completo, metallo massiccio, con rosetta D = ø 25 mm	Messing, verchromt Ottone, cromato	40.000.931.00	F	54.–	58.–	40.000.931.01	30.–	32.–
		Ice	40.001.580.00	F	132.–	143.–	40.001.580.01	108.–	117.–
		Edelstahl Acciaio inox	40.000.933.00	F	107.–	116.–	40.000.933.01	83.–	90.–
		Platin, matt Platino, opaco	40.001.454.00	F	132.–	143.–	40.001.454.01	108.–	117.–
		PVD-Beschichtung, Graphit Rivestimento a PVD, grafite	40.001.283.00	F	132.–	143.–	40.001.283.01	108.–	117.–
		PVD-Beschichtung, Inox Black Rivestimento a PVD, Inox Black	40.002.528.00	F	132.–	143.–	40.002.528.01	108.–	117.–
		Pulverbeschichtung schwarz, matt Rivestimento con polvere nero, opaco	40.002.156.00	F	125.–	135.–	40.002.156.01	101.–	109.–
	Nasslackierung schwarz, seidenglanz Verniciatura all'acqua, color nero satinato lucido	40.002.356.00	F	125.–	135.–	40.002.356.01	101.–	109.–	
<b>Advant</b>	Zugknopf, komplett, massiv Metall, mit Sockel D = ø 25 mm Pomolo, completo, metallo massiccio, con zoccolo D = ø 25 mm	Messing, verchromt Ottone, cromato	40.000.935.00	F	27.–	29.–	40.000.935.01	3.–	4.–
		Edelstahl Acciaio inox	40.002.546.00	F	56.–	61.–	40.002.546.01	32.–	35.–
		Pulverbeschichtung schwarz, matt Rivestimento con polvere nero, opaco	40.002.766.00	F	74.–	80.–	40.002.766.01	50.–	54.–
<b>Prime</b>	Zugknopf, komplett, Kunststoff, mit Sockel D = ø 25 mm Pomolo, completo, plastica, con zoccolo D = ø 25 mm	ABS-Kunststoff, verchromt ABS, cromato	40.001.006.00	F	22.–	24.–			
		ABS-Kunststoff, schwarz, matt ABS, nero, opaco	40.002.765.00	F	24.–	26.–	40.002.765.01	0.–	0.–
<b>Dorn- bracht<sup>3</sup></b>	Drehknopf-Garnitur, komplett, mit Rosette D = ø 55 mm Pomolo girevole, completo, con rosetta D = ø 55 mm	Messing, verchromt Ottone, cromato	40.001.422.00	H	173.–	187.–	40.001.422.01	149.–	161.–
		Platin, matt Platino, opaco	40.001.423.00	H	276.–	298.–	40.001.423.01	252.–	272.–
<b>Druck- knopf 3/4/5</b>	Druckknopf, komplett, D = ø 44 mm Pulsante, completo D = ø 44 mm	Edelstahl, massiv Acciaio inox, massiccio	40.003.081.00	F	126.–	136.–	40.003.081.01	81.–	88.–
		Pulverbeschichtet schwarz, matt Rivestimento con polvere nero, opaco	40.003.082.00	F	142.–	154.–	40.003.082.01	97.–	105.–
		PVD-Beschichtung Graphit Rivestimento a PVD, grafite	40.003.083.00	F	154.–	166.–	40.003.083.01	109.–	118.–
		PVD-Beschichtung Inox Black Rivestimento a PVD, Inox Black	40.003.084.00	F	154.–	166.–	40.003.084.01	109.–	118.–
		Chrom Cromato	40.003.085.00	F	69.–	75.–			

<sup>1</sup> Nur in Verbindung mit ausgewählten Spülen und Becken erhältlich / Solo in abbinamento a lavelli e lavabi selezionati

<sup>2</sup> Kann mit oder ohne Rosette montiert werden / Può essere montato con o senza rosetta

<sup>4</sup> Nicht kompatibel mit Brooklyn Becken / Montaggio incompatibile con il lavello Brooklyn

<sup>3</sup> Nicht kompatibel mit Raumspaar Desino / Non compatibile con salvaspazio Desino

<sup>5</sup> Nicht kompatibel mit Unterschrank-Montagewinkel / Non compatibile con staffa di montaggio per base

# Zeichenlegende

## Legenda

### Allgemein

#### In generale

 Neuheit 2026  
Novità 2026

 Hinweis  
Nota

 Zusätzliche Information  
Informazioni supplementari

 Green Line ist eine eigenständige auf Nachhaltigkeit ausgerichtete Produktausführung.  
Green Line è una versione di prodotto autonoma calibrata sulla sostenibilità.

 Artikel wird ab Lager geliefert  
Articolo consegnabile da magazzino

 Solange Vorrat  
Fino ad esaurimento scorte

 Unterschrankmasse in cm  
Dimensioni base in cm

 Barrierefrei  
Senza barriere

### Ablauf- und Überlauf

#### Troppopieno e scarico

 Desino: Verdeckter Ablauf mit untenliegendem Korb  
Desino: Scarico coperto con griglietta inferiore

 Obenliegendes Sieb  
Griglietta superiore

 eFlow mit eControl  
eFlow con eControl

 Schwenkbare Überlaufkappe  
Placchetta di troppopieno a ribalta

 Verdeckter Überlauf  
Troppopieno coperto

### Dispenser und Zugknöpfe

#### Distributori e Pomoli

 Dispenser: alle Modelle  
Distributori: tutti i modelli

 Dispenser: kein Einbau möglich  
Distributori: Nessun montaggio possibile

 Dispenser: frei positionierbar  
Distributori: posizione a scelta

 Advant, Chrom: Im Standard-Lieferumfang enthalten  
Advant, Cromato: Compreso nella fornitura standard

 Prime, Chrom: Im Standard-Lieferumfang enthalten  
Prime, Cromato: Compreso nella fornitura standard

 Drehknopf Schock, Chrom  
Pomolo girevole Schock, Cromato

### Montage

#### Montaggio

 Ventilmontage ab Werk  
Montaggio della piletta in fabbrica

 Ventilvormontage ab Werk  
Premontaggio della piletta in fabbrica

 Ohne Ventilmontage  
Senza montaggio della piletta

 Spülentyp ist mit Klick-Montage für «Holz» oder «Stein» erhältlich. Bitte Typ bei der Bestellung angeben.  
Tipo di lavello disponibile con montaggio a scatto per «legno» o «pietra». In sede di ordine, si prega di indicare il modello.

### Armaturen

#### Rubinetteria

 Kartusche keramisch  
Cartuccia a dischi ceramic

 Schwenkbereich  
Raggio d'azione

 Durchfluss l/min. (3 bar)  
Scarico l/min. (3 bar)

 Auslauf mit Nylonschlauch  
Doccia con flessibile in nylon

 Auslauf mit Metallschlauch  
Doccia con flessibile in metallo

 Flexible Anschlussschläuche  
Raccordi flessibili

 Mit Laminarstrahl  
Con getto laminare

# Kombinieren – Profitieren

## Approfittate delle combinazioni

Basis für das Angebot «Kombinieren – Profitieren» sind immer die Spülen und Becken. Aufbauend darauf können Sie Produkte aus weiteren Kategorien ergänzen. Pro Kategorie erhalten Sie einen Zusatzrabatt von 1,5%.

Alla base dell'offerta «Approfittate delle combinazioni» sono sempre i lavelli. Su questa base è possibile aggiungere prodotti di altre categorie. Riceverete uno sconto aggiuntivo dell'1,5% per ogni categoria.

### So funktioniert's (gilt pro Bestellung / Kommission\*):

1. Bestellen Sie als Basis die gewünschten Spülen und Becken.
2. Bestellen Sie aus mindestens einer weiteren Produktkategorie ein zusätzliches Produkt.
3. Der Zusatzrabatt wird nun auf den gewählten Produktkategorien (inkl. Spülen und Becken) kumuliert aktiv.
4. Bei Bestellungen aus jeder weiteren Produktkategorie erhalten Sie nochmals 1,5% Zusatzrabatt dazu. So erhalten Sie auf die gewählten Produkte bis zu 6% kumulierten Zusatzrabatt.

### Ecco come funziona (si applica per ordine / commissione\*):

1. Ordinare i lavelli come base.
2. Ordinare un prodotto aggiuntivo da almeno un'altra categoria di prodotti.
3. Lo sconto aggiuntivo è ora cumulativamente attivo sulle categorie di prodotti selezionate (inclusi i lavelli).
4. Per ordini di ogni categoria di prodotti aggiuntiva, riceverete un ulteriore sconto dell'1,5%. Ciò significa che riceverete fino al 6% di sconto aggiuntivo cumulativo sui prodotti selezionati.

Spülen und Becken  
Lavelli

1,5%

+

Armaturen  
Robinetteria

1,5%

+

Abfallsysteme  
Sistemi di raccolta rifiuti

1,5%

+

Dispenser  
Distributori

1,5%

=

**Bis zu**  
**6%**  
**Zusatzrabatt**

**Fino al**  
**6%**  
**di sconto**  
**aggiuntivo**

### \* Allgemeine Bestimmungen:

Der Zusatzrabatt «Kombinieren – Profitieren» gilt zusätzlich auf die bestehenden Grundkonditionen und Nettopreise (weitere Rabatte und Vereinbarungen sind ausgeschlossen). Der Zusatzrabatt gilt pro Bestellung mit einheitlichem Liefertermin und wird nicht offeriert.

### \* Condizioni generali:

Lo sconto aggiuntivo «Approfittate delle combinazioni» si applica in aggiunta alle condizioni di base e ai prezzi netti esistenti (sono esclusi ulteriori sconti e accordi). Lo sconto aggiuntivo si applica per ogni ordine con la stessa data di consegna e non è offerto.

# SUTER

## Die Welt des Edelstahls – online erkunden! Il mondo dell'acciaio inox – scopritelo online!

Ihre Lieblingsprodukte, Zubehör und Ersatzteile sind nur einen Klick entfernt.  
I vostri prodotti preferiti, gli accessori e i ricambi sono a portata di clic.

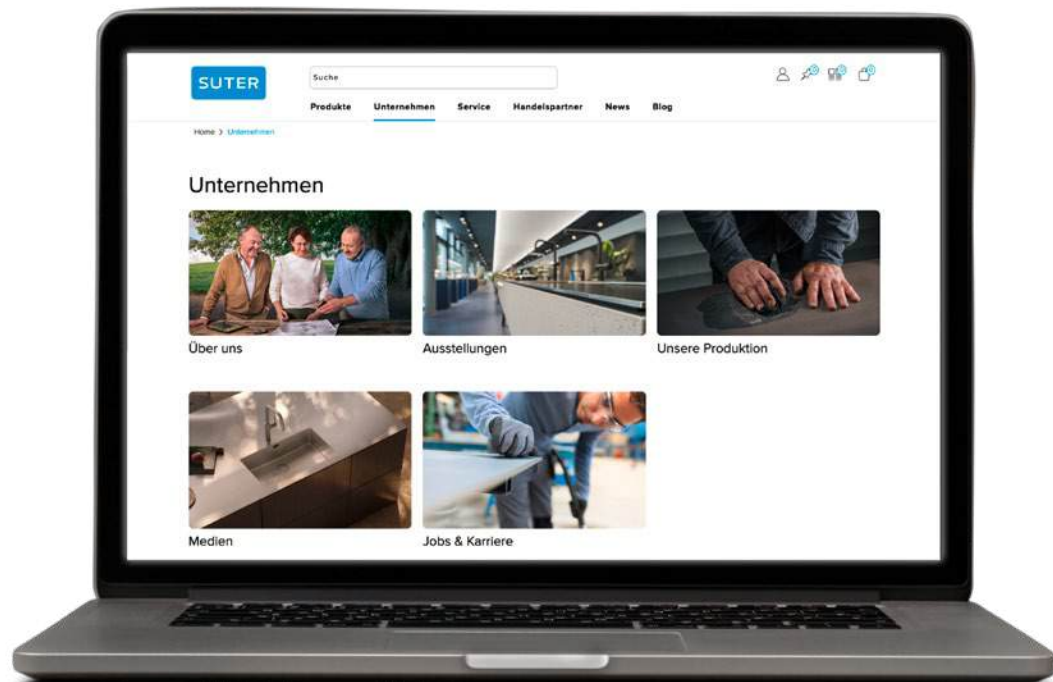

Geniessen Sie die Bequemlichkeit, rund um die Uhr online einzukaufen.  
Erleben Sie, wie einfach es ist, hochwertige Edelstahlprodukte zu finden.

**Willkommen bei suter.ch – wo Innovation und Einfachheit aufeinandertreffen!**

Godetevi la comodità di fare acquisti online 24 ore su 24.

Scoprite quanto sia facile trovare prodotti in acciaio inox di alta qualità.

**Benvenuti su suter.ch, dove innovazione e semplicità s'incontrano!**

# SUTER

**Suter Inox AG**

Schachenstrasse 20  
CH-5116 Schinznach-Bad

T +41 58 263 64 00

suter@suter.ch  
suter.ch

**Hauptsitz und Ausstellung Schinznach-Bad****Sede e l'esposizione Schinznach-Bad**

Schachenstrasse 20  
CH-5116 Schinznach-Bad

T +41 58 263 64 00

**Filiale und Ausstellung Zürich****Filiale e esposizione di Zurigo**

Hardturmstrasse 125  
CH-8005 Zürich

T +41 58 263 64 02

**Filiale und Ausstellung Crissier****Filiale e esposizione di Crissier**

Chemin des Lentillières 5g  
CH-1023 Crissier

T +41 58 263 64 03

**Bestellungen**

T +41 58 263 64 20  
bestellungen@suter.ch

**Bestellungen Massanfertigung**

T +41 58 263 64 40  
bestellungen\_ma@suter.ch

**Offerten**

T +41 58 263 64 60  
offerten@suter.ch

**Kundendienst**

T +41 58 263 64 80  
kundendienst@suter.ch

**Ordinazioni**

T +41 58 263 64 20  
ordinazioni@suter.ch

**Ordinazioni soluzioni a misura**

T +41 58 263 64 40  
ordinazioni\_ma@suter.ch

**Offerte**

T +41 58 263 64 60  
offerte@suter.ch

**Servizio clienti**

T +41 58 263 64 80  
servizioclienti@suter.ch

