

SK Sento



Sento Sidelever

Pendelauslauf
Bec pendulaire
Bocca oscillante
Professional spout



Sento Sidelever C

Zugauslauf
Goulot extractible
Bocca estraibile
Pull down



Sento Sidelever L

Zugauslauf
Goulot extractible
Bocca estraibile
Pull out



Sento Sidelever

Schwenkauslauf
Goulot tournant
Bocca girevole
Swivel spout



DE Diese Anleitung muss dem Benutzer ausgehändigt werden.

Garantie/Haftung nur bei Montage gemäss Anleitung durch eine konzessionierte Fachkraft und gemäss örtlicher Vorschriften.

FR Cette instruction doit être remise à l'utilisateur.

Garantie/responsabilité uniquement assurées en cas de montage conforme au mode d'emploi, effectué par un spécialiste concessionnaire et en fonction des prescriptions locales.

IT Le presenti istruzioni devono essere consegnate all'utilizzatore.

Garanzia/responsabilità assicurate soltanto in caso di montaggio conforme alle istruzioni per l'uso e eseguito da uno specialista concessionario in funzione delle prescrizioni locali.

EN This instruction must be given to the user.

Guarantee/Liability only when assembled by an approved specialist in accordance with the instructions and local regulations.

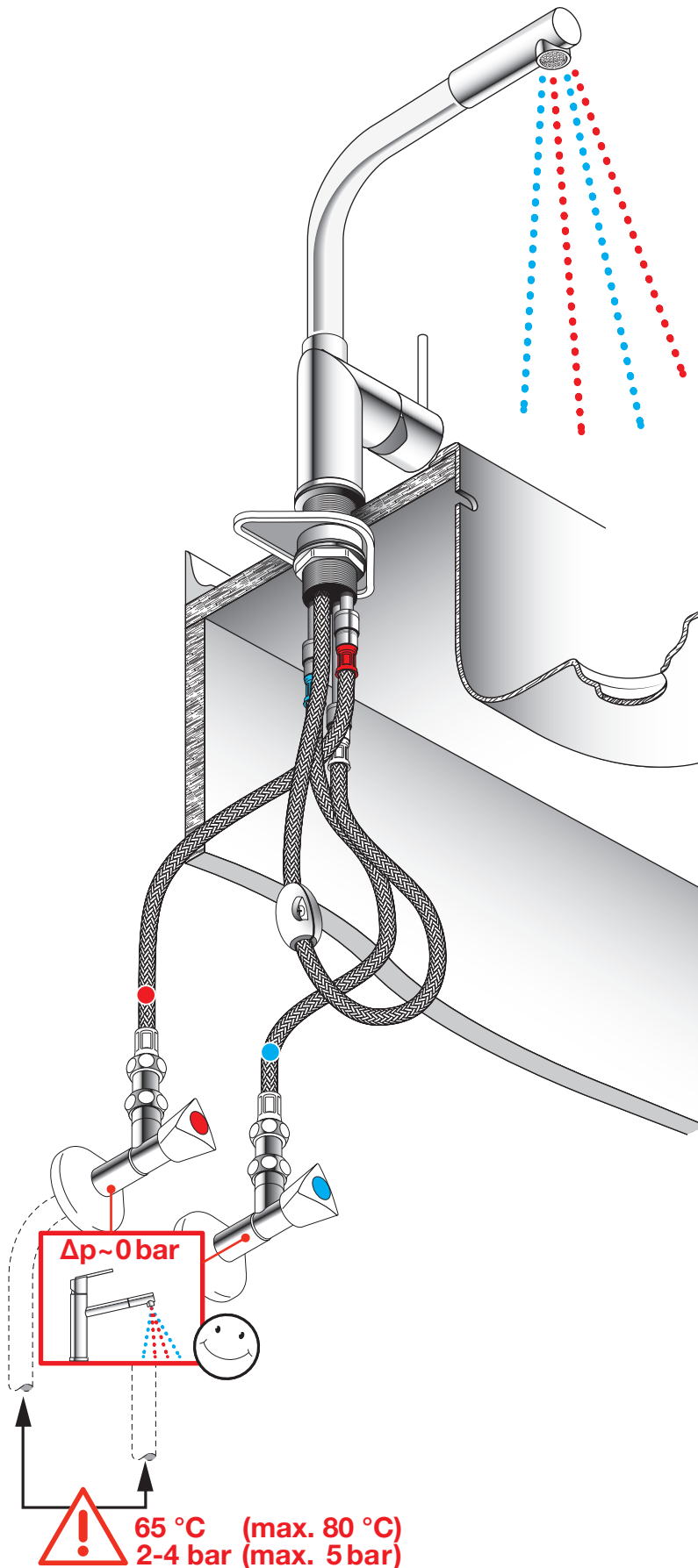

DE Wichtige Information – bitte vor der Inbetriebnahme beachten:

- Nur Originalteile von SIMILOR verwenden.
- In das Wasserversorgungssystem muss ein Trinkwasserfilter eingebaut werden.
- Für Funktionsstörungen, die durch eine fehlerhafte Installation oder eine schlechte Wasserqualität begründet sind, übernimmt SIMILOR keine Verantwortung.

FR Informations importantes à observer avant la mise en service:

- Utilisez uniquement des pièces d'origine SIMILOR.
- Un filtre à eau potable doit être monté dans le système d'alimentation en eau.
- SIMILOR décline toute responsabilité en cas de dysfonctionnement résultant d'une installation incorrecte ou d'une mauvaise qualité de l'eau.

IT Importanti informazioni da osservare prima di effettuare un ordine:

- Usare solo pezzi originali SIMILOR.
- Nel sistema di adduzione dell'acqua deve essere inserito un filtro per l'acqua potabile.
- SIMILOR declina ogni responsabilità per malfunzionamenti risultanti dalla scorretta installazione o dalla scarsa qualità dell'acqua.

EN Important information to be observed before commissioning:

- Use only original parts from SIMILOR.
- A drinking water filter must be fitted in the water supply system.
- SIMILOR accepts no responsibility for malfunctions resulting from incorrect installation or poor water quality.

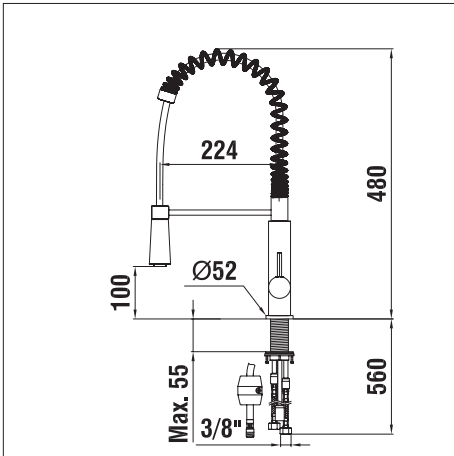

Sento Sidelever

Pendelauslauf
 Bec pendulaire
 Bocca oscillante
 Professional spout

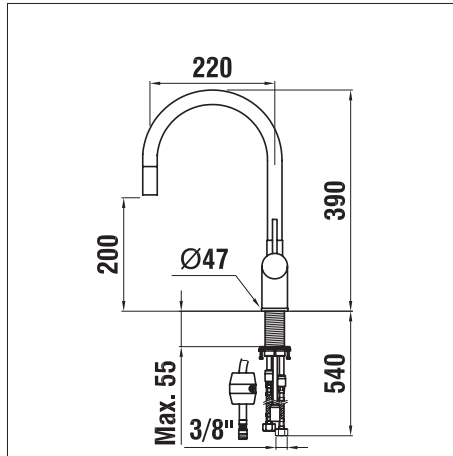

Sento Sidelever C

Zugauslauf
 Goulot extractible
 Bocca estraibile
 Pull down

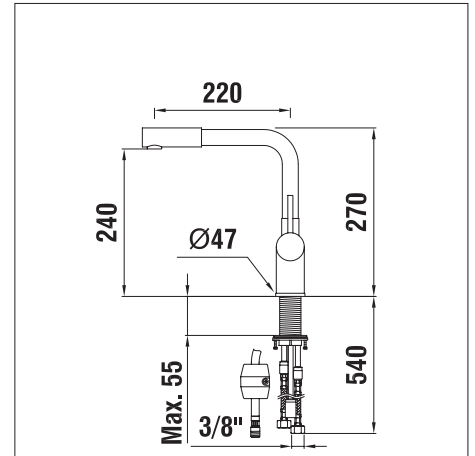

Sento Sidelever L

Zugauslauf
 Goulot extractible
 Bocca estraibile
 Pull out

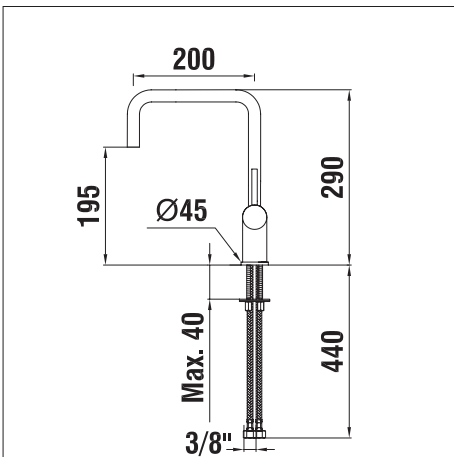

Sento Sidelever

Schwenkauslauf
 Goulot tournant
 Bocca girevole
 Swivel spout

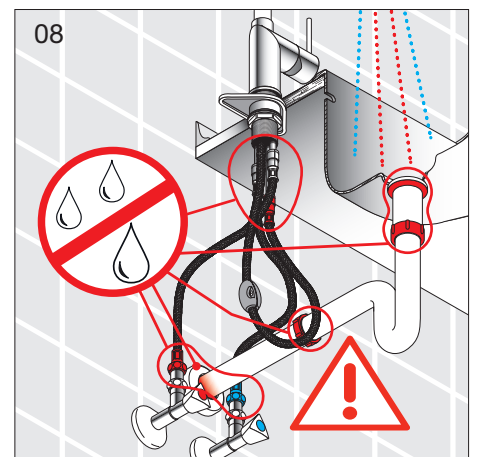
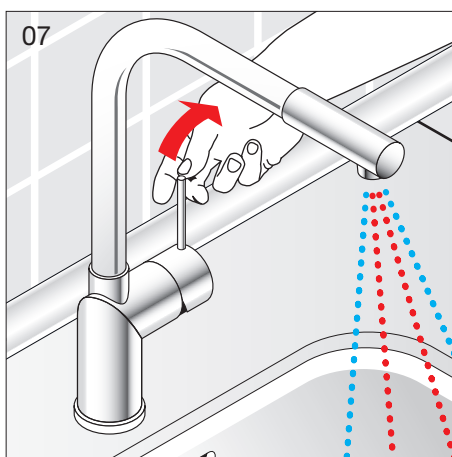
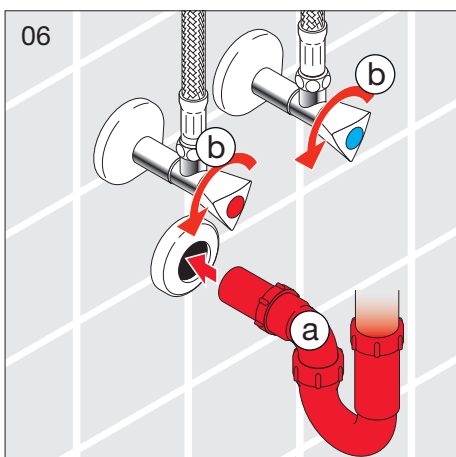
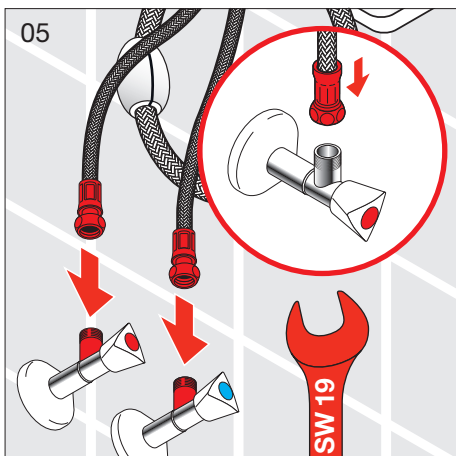
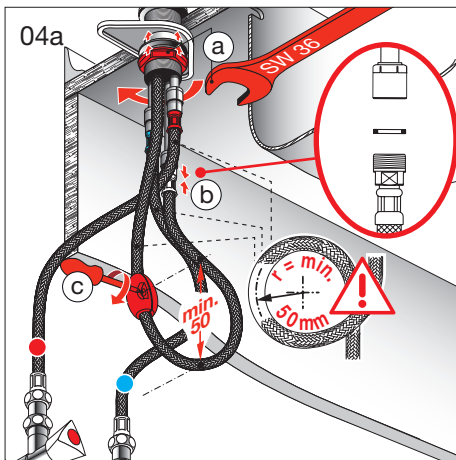
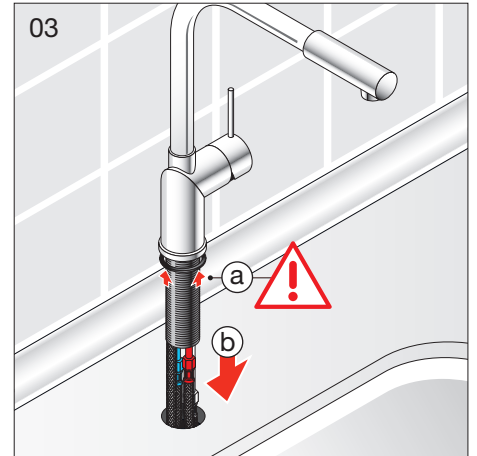
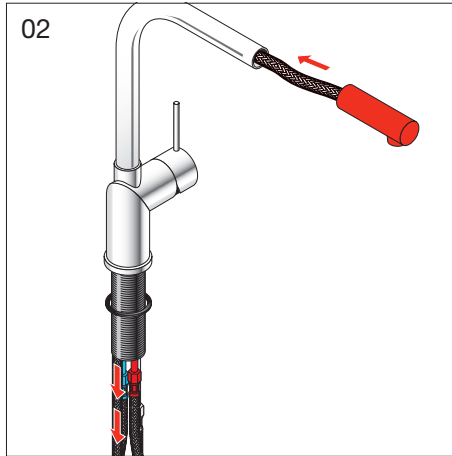
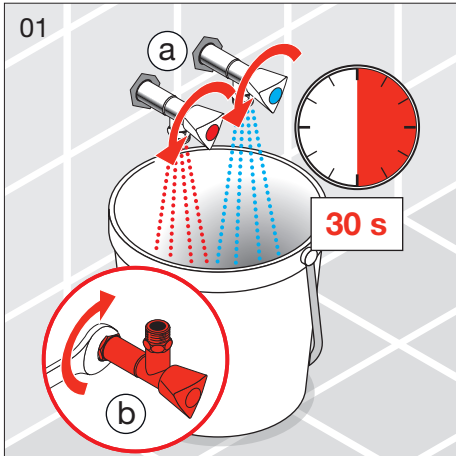

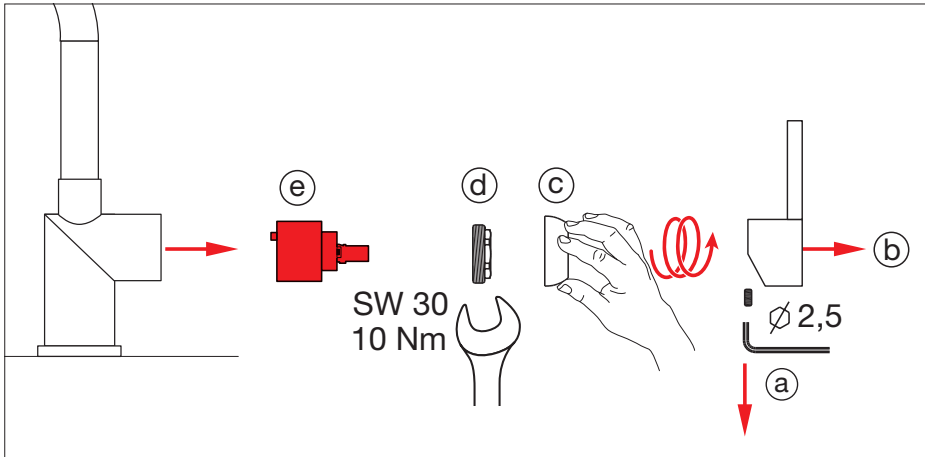

- Das Auswechseln der Patrone muss bei abgeschalteter Wasserspeisung erfolgen.
- Le remplacement de la cartouche doit être réalisé après coupure de l'alimentation des eaux.
- La cartuccia va sostituita dopo chiusura dell'alimentazione dell'acqua.
- The water supply must be switched off before the cartridge is replaced.

Rückfluss-Schutzvorrichtung
Clapets anti-retour
Protezione antiriflusso
Backflow protection

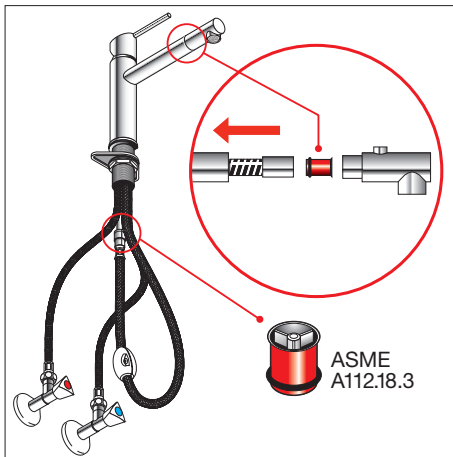

Nur für USA / Canada:
Uniquement pour les USA / Canada:
Solo per USA / Canada:
Just for USA / Canada:

Rückfluss-Schutzvorrichtung
in Übereinstimmung mit ASME A112.18.3 (2003):

- Diese Einheit beinhaltet:
- 1 Rückflussverhinderer
 - 1 Rückflussverhinderer mit Mengenbeschränkung

WICHTIG
Während der Installation dürfen die Rückflussverhinderer nicht entfernt werden.

Dispositif de protection anti-retour
en accord avec ASME A112.18.3 (2003)

- Cette unité comprend:
- 1 clapet anti-retour
 - 1 clapet anti-retour avec limitation de débit

IMPORTANT
Ne pas démonter les clapets anti-retour lors de l'installation.

Protezione antiriflusso
conforme allo standard ASME A112.18.3 (2003).

- Questa unità comprende:
- 1 valvola antiriflusso
 - 1 valvola antiriflusso con limitazione di portata

IMPORTANTE
Durante l'installazione non si devono togliere le valvole antiriflusso.

Backflow protection device
according to ASME A112.18.2 (2003)

- This device contains:
- 1 plain check-valve
 - 1 check-valve with flow restrictor

IMPORTANT
Do not remove check-valves when installing faucet.

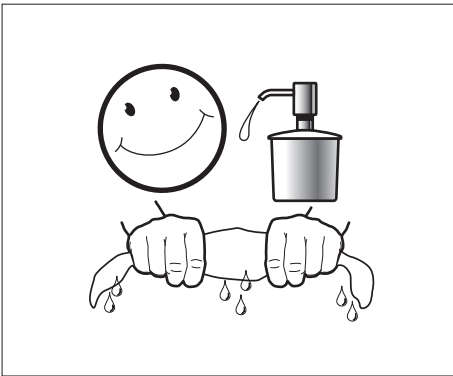
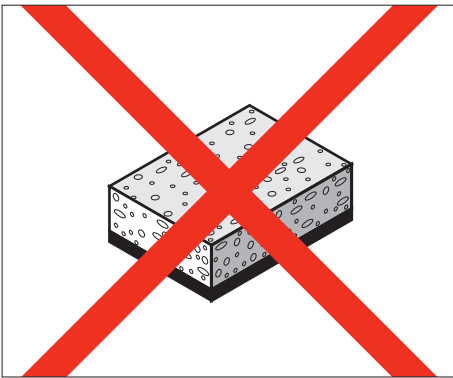

DE Pflegeanleitung

Die Oberfläche ist einfach zu reinigen und zu pflegen. Die glatte Oberfläche nimmt kaum Schmutz an. Zur regelmässigen Pflege weiches Tuch, Seifenlauge und Wasser verwenden. Mit trockenem Tuch abtrocknen.

Vermeiden Sie den Einsatz von Scheuermitteln oder Lösungsmitteln, die die Oberfläche beschädigen.

Schäden, die durch unsachgemässe Behandlung durch den Benutzer entstehen, entziehen sich unserer Garantieleistung.

FR Mode d'entretien

Cette surface est facile à entretenir. Très lisse, elle retient fort peu la saleté. Pour un entretien régulier, utiliser un chiffon doux, du savon et de l'eau. Essuyer avec un chiffon sec.

Évitez d'utiliser des détergents ou des solvants qui endommageraient cette surface.

Les dommages résultant d'un traitement non conforme effectué par l'utilisateur sont exclus de la garantie que nous offrons.

IT Modalità di manutenzione

Questa superficie è facile da pulire. Molto liscia, trattiene poco lo sporco. Per una pulizia regolare, usare un panno morbido, sapone e acqua. Asciugare con uno straccio asciutto.

Evitare di usare detersivi o solventi che potrebbero danneggiare la superficie.

I danni dovuti a un trattamento non conforme effettuato dall'utente non sono coperti dalla nostra garanzia.

EN Maintenance instructions

The surface is simple to clean and care for. The smooth surface hardly accumulates any dirt. Use soft cloth, soapy solution and water for regular care. Wipe with a dry cloth.

Avoid the use of abrasives or solvents, which damage the surface.

Damage caused by inappropriate treatment by the user, is not covered by our guarantee.

Similor AG Wahlenstrasse 46, CH-4242 Laufen
Customer Services CH 0848 000 166
Tel. +41 (0)61 765 73 33, Fax +41 (0)61 765 73 34
www.similor.ch, info@similor.ch

Service Centers Similor AG, Industriestrasse 41a, CH-8304 Wallisellen, Tel. 0848 111 166
Similor AG, Wilkerstrasse 20, CH-3097 Liebefeld, Tel. 0848 111 166
Similor AG, Chemin de la Marbrerie 10, CH-1227 Carouge, Tel. 0848 111 166

arwa, Similor Kugler and Sanimatic are trademarks of Similor.

arwa 
sanimatic 
SIMILOR KUGLER
WATER INSPIRATION  SINCE 1854